

GFK-1179
New In Stock!
~~GE Fanuc~~ Manuals

<http://www.pdfsupply.com/automation/ge-fanuc-manuals/genius/GFK-1179>

genius
1-919-535-3180

Installation Requirements for Conformance to Standards

www.pdfsupply.com

Email: sales@pdfsupply.com



GE Fanuc Automation

Programmable Control Products

*Installation Requirements
for Conformance to Standards*

GFK-1179H

June 2000

Warnings, Cautions, and Notes as Used in this Publication

Warning

Warning notices are used in this publication to emphasize that hazardous voltages, currents, temperatures, or other conditions that could cause personal injury exist in this equipment or may be associated with its use.

In situations where inattention could cause either personal injury or damage to equipment, a Warning notice is used.

Caution

Caution notices are used where equipment might be damaged if care is not taken.

Note

Notes merely call attention to information that is especially significant to understanding and operating the equipment.

This document is based on information available at the time of its publication. While efforts have been made to be accurate, the information contained herein does not purport to cover all details or variations in hardware or software, nor to provide for every possible contingency in connection with installation, operation, or maintenance. Features may be described herein which are not present in all hardware and software systems. GE Fanuc Automation assumes no obligation of notice to holders of this document with respect to changes subsequently made.

GE Fanuc Automation makes no representation or warranty, expressed, implied, or statutory with respect to, and assumes no responsibility for the accuracy, completeness, sufficiency, or usefulness of the information contained herein. No warranties of merchantability or fitness for purpose shall apply.

The following are trademarks of GE Fanuc Automation North America, Inc.

Alarm Master	Genius	PROMACRO	Series Six
CIMPLICITY	Helpmate	PowerMotion	Series Three
CIMPLICITY 90-ADS	Logicmaster	PowerTRAC	VersaMax
CIMSTAR	Modelmaster	Series 90	VersaPro
Field Control	Motion Mate	Series Five	VuMaster
GEnet	ProLoop	Series One	Workmaster

This manual describes the installation requirements for programmable control products used in industrial environments, specifically, in situations where compliance to standards or directives from the Federal Communications Commission, the Canadian Department of Communications, or the European Union is necessary. The information in this manual is applicable for GE Fanuc Series 90-70 and Series 90-30 programmable controller products, Genius I/O products, VersaMax I/O, and Field Control Distributed I/O and Control products.

Revisions to this Manual

The following is a list of the revisions to this manual as compared to version GFK-1179G:

- Revised Comments for ISO9001 under Agency Approvals Overview on page A-1.

Content of This Manual

Chapter 1. Installation Guidelines: Describes installation requirements for GE Fanuc Programmable Controller products.

Chapter 2. Safety-Related Guidelines: Describes safety-related guidelines related to the installation of PLC systems in the European Union.

Appendix A. Product Agency Approvals, Standards, and General Specifications: This appendix is a duplicate of data sheet GFK-0867, which lists the product approvals and standards, and provides general specifications to which GE Fanuc products must conform to when installed in industrial environments.

Appendix B. Cable Shield Clamping Assembly: This appendix describes the Cable Shield Clamping Assembly that can be used with Series 90 programmable controllers that are installed in severe industrial environments in order to meet the requirements for higher EMC immunity.

Appendix C. Shielded Cable Alternative to Conduit: This appendix provides information about using shielded cable as an alternative to metal conduit for meeting FCC or CISPR radiated emissions requirements.

Appendix D. Radiated Emissions Compliant Products: This appendix provides a list of products that do not require installation in a metal enclosure in order to be compliant with the radiated emissions standards defined in Appendix A.

Appendix E. Industrial Exemption Products: This appendix provides a list of products that have taken the Industrial Exemption according to 47CFR15.

Related Publications

For more information, refer to these publications:

Genius[®] I/O System User's Manual (GEK-90486-1).

Genius[®] I/O Discrete and Analog Blocks User's Manual (GEK-90486-2)

Series 90[™]-70 PLC Installation Manual (GFK-0262)

Series 90[™]-70 PLC Data Sheets Manual (GFK-0600)

Series 90[™]-30 PLC Installation Manual (GFK-0356)

Series 90[™]-30 I/O Specifications Manual (GFK-0898)

Field Control[™] Distributed I/O and Control System, Genius[®] Bus Interface Unit User's Manual (GFK-0825)

Field Control[™] Distributed I/O and Control System, I/O Modules User's Manual (GFK-0826)

VersaMax[™] I/O and Option Modules Manual (GFK-1504)

VersaMax[™] Network Interface Units Manual (GFK-1535)

VersaMax[™] Program Reference Manual (GFK-1549)

Chapter 1	Installation Guidelines	1-1
	Introduction	1-1
	U.S., Canadian and Australian Regulations	1-1
	Verification and Industrial Exemption for U.S. and Canadian Installations.....	1-2
	European Union Directives	1-3
	EMC Directive	1-4
	Grounding the Controls Enclosure	1-5
	Cable Shield Clamping Assembly.....	1-6
	I/O Power Sources.....	1-6
	All Analog Modules	1-6
	Series 90-30 Products	1-6
	General Installation Guidelines.....	1-6
	Safety and Reference Ground.....	1-7
	Additional Guidelines for Specific Components	1-8
	<i>Expansion and Remote Cables</i>	1-8
	<i>IC693ALG392/442</i>	1-8
	<i>IC693APU300</i>	1-8
	<i>IC693APU301/302</i>	1-8
	<i>IC693CMM321</i>	1-9
	<i>IC693CPU351</i>	1-9
	<i>IC693MCM001</i>	1-9
	<i>IC693MDL654</i>	1-9
	<i>IC693PRG300</i>	1-9
	<i>IC693PWR322/328</i>	1-9
	Series 90-70 Products	1-10
	General Installation Guidelines.....	1-10
	Safety and Reference Ground.....	1-10
	Additional Guidelines for Specific Components	1-11
	<i>IC697BEM741/742 and IC687BEM741/742</i>	1-11
	<i>IC697MCM001</i>	1-11
	<i>IC697MDL651</i>	1-11
	<i>IC697PCM711/PCM712/CMM711/CMM712/ADC701</i>	1-11
	Genius I/O Products	1-12
	General Installation Guidelines.....	1-12
	Additional Guidelines for Specific Components	1-12
	<i>IC660BBA023/103</i>	1-12
	<i>IC660ELB921/ELB922</i>	1-12
	Field Control Products.....	1-13
	General Installation Guidelines.....	1-13
	Genius Stations.....	1-13
	FIP Stations	1-13
	<i>IC670FBI002</i>	1-13
	<i>IC670FBI102</i>	1-13
	ProfiBus Station.....	1-14
	Additional Guidelines for Specific Components	1-14
	<i>IC670ALG320</i>	1-14
	VersaMax Products	1-15
	General Installation Guidelines.....	1-15
	<i>IC200MDD841</i>	1-15

Contents

	<i>IC200PWR001/002</i>	1-15
	<i>IC200PWR101/102</i>	1-15
	DataPanel Products.....	1-15
	<i>IC752DFT100/101</i>	1-15
	Low Voltage Directive.....	1-16
	Installation Requirements	1-16
	Series 90-30 Products.....	1-17
	Handling Modules	1-17
	Machinery Directive	1-18
Chapter 2	Safety-Related Guidelines	2-1
	Safety-Related Guidelines for Users of GE Fanuc PLC Products to be Installed in the European Union.....	2-1
	Introduction.....	2-1
Appendix A	Product Agency Approvals, Standards, and General Specifications	A-1
Appendix B	Cable Shield Clamping Assembly	B-1
	Features	B-1
	Functions.....	B-1
	Outline Drawing of Mounting Plate	B-2
	Installing the Assembly	B-3
	Maximum and Minimum Diameter Cable	B-4
	Removing Cable Cover	B-4
	Mounting on a Series 90-70 PLC Rack	B-5
Appendix C	Shielded Cable Alternative to Conduit.....	C-1
	Communication Cables	C-1
	I/O Cables	C-1
	Analog/High Speed Cables	C-1
	Power Input to Enclosure.....	C-1
	AC Power Input RF Filter	C-2
	DC Power Input RF Filter	C-2
	Shield Termination	C-2
	Compression Connectors.....	C-2
	Specialty Shielded Cable Vendors.....	C-3
Appendix D	Radiated Emissions Compliant Products	D-1
Appendix E	Industrial Exemption Products.....	E-1

Figure 1-1. GE Fanuc’s Path to Comply with the EMC Directive..... 1-4

Figure 1-2. Recommended System Grounding..... 1-5

Figure 1-3. Alternative to Cable Shield Clamping Assembly..... 1-6

Figure 1-4. Installed PLC System 1-7

Figure 1-5. Communication Cable Requirements..... 1-14

Figure 1-6. GE Fanuc’s path to comply with the Low Voltage Directive..... 1-16

Figure 1-7. GE Fanuc’s path for supporting machine manufacturer’s compliance with the Machinery Directive 1-18

Figure B-1. Ground Plate Outline, Mounting Dimensions, and Cable Clamp..... B-2

Figure B-2. Example of Cable Shield Clamping Assembly Installation B-3

Figure B-3. Cross Section of Cable Secured by Clamp..... B-4

Figure B-4. Clamped Cable with Exposed Shield..... B-4

Figure B-5. Cable Shield Clamping Assembly Mounted on a Series 90-70 PLC Rack..... B-5

Figure C-1. Unshielded I/O Cable with a Single Shield..... C-2

Figure C-2. Communication Cables Sharing an RF Shield C-3

Chapter 1

Installation Guidelines

Introduction

The installation manuals for each product line provide detailed information regarding the equipment's proper installation, startup, and use. This manual provides the additional installation requirements needed to comply with governing bodies and standards agencies, such as Federal Communications Commission (FCC), Industry Canada and Standards Council of Canada (SCC), European Union (EU), and Australian Communications Authority (ACA).

This manual describes the standards to which GE Fanuc products must conform for installation in industrial environments. The information in this manual is applicable for the following GE Fanuc product lines: Series 90-70, Series 90-30, Field Control, Genius, Versamax, QuickPanel, DataPanel, and Operator Interface.

U.S., Canadian and Australian Regulations

U.S., Canadian, and Australian regulations are intended to prevent equipment from interfering with approved transmissions or with the operation of other equipment through the AC power source.

The Series 90-70, Series 90-30, Field Control, Genius, and VersaMax family of products have been tested and found to meet or exceed the requirements of U.S.(47 CFR 15), Canadian (ICES-003), Australian (AS/NZS 3548), and European (EN55022) regulations for Class A digital devices when installed in accordance with the guidelines noted in the appropriate product section. These various regulations share commonality in content and test levels with that of CISPR 22 and based on this commonality testing to the each individual standard was deemed unnecessary.

The FCC requires the following note to be published according to FCC guidelines:

Note

This equipment generates, uses, and can radiate radio frequency energy and, if not installed in accordance with this instruction manual, may cause harmful interference to radio communications. It has been tested and found to comply with the limits for a Class A digital device pursuant to Part 15 of the FCC Rules, which are designed to provide reasonable protection against harmful interference when operated in a commercial environment. Operation of this equipment in a residential area is likely to cause harmful interference, in which case the user will be required to correct the interference at his own expense.

Industry Canada requires the following note to be published:

Note

This Class A digital apparatus complies with Canadian ICES-003.

Verification and Industrial Exemption for U.S. and Canadian Installations

With regard to U.S. and Canadian installation regulations, users may wish to consider the industrial plant provisions of FCC regulation 47 CFR 15.103(b) and Industry Canada regulation ICES-003, Section 1.2.2(b). Appendix E contains a list of all GE Fanuc products that have taken this Industrial Exemption. For products not mentioned in Appendix E, GE Fanuc has elected the "verification" route to Canadian and U.S. compliance.

European Union Directives

The European Union (EU) has implemented directives to harmonize product safety standards within the EU. Compliance with the EU directives is required for products installed within the EU. The EU has established a transition period during which manufacturers must become compliant with each directive. After the end of the transition period, products installed within the EU must comply with each applicable directive.

Two EU directives apply directly to GE Fanuc's PLC products:

- The **EMC Directive (89/336/EEC, 92/31/EEC, 93/68/EEC)** deals with electromagnetic emissions and immunity. Transition period ended December 31, 1995.
- The **Low Voltage Directive (73/23/EEC, 93/68/EEC)** deals with electrical safety. Transition period ended December 31, 1996.

GE Fanuc PLC products meet the CE-Marking Directive (93/68/EEC) indicating compliance to both EMC and Low Voltage Directives. In addition, GE Fanuc will issue Declarations of Conformity that specify the directive(s) and the catalog numbers of the products covered. PLC products must be installed using the instructions in the installation manuals and in the applicable sections of this manual.

Manufacturers of machines to be installed within the EU must also comply with the following directive:

- The **Machinery Directive (89/392/EEC, 91/368/EEC, 93/44/EEC, 93/68/EEC)** deals with machine safety. Transition period ended December 31, 1994.

The Machinery Directive applies to the entire machine and covers all safety aspects of the machine, including electrical safety. **Compliance with the Machinery Directive is the machine manufacturer's responsibility.** GE Fanuc supports machine manufacturers by complying with the safety requirements of IEC 1131-2, the applicable European standard for programmable controllers.

EMC Directive

The EMC Directive is concerned with the immunity of electrical equipment to a variety of interference sources and the emissions from electrical equipment which could interfere with the operation of other equipment. The EMC Directive applies to complete installations, and since GE Fanuc PLCs are included in the installation, GE Fanuc is supporting the EMC Directive by testing and CE marking a subset of our equipment.

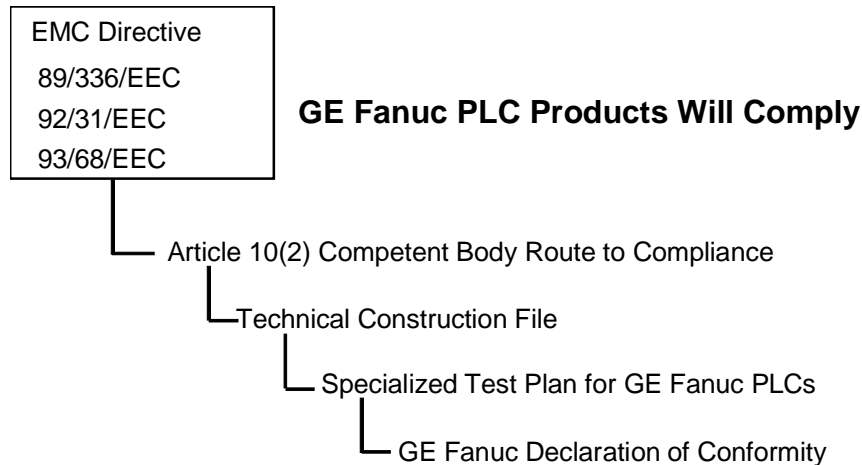

Figure 1-1. GE Fanuc’s Path to Comply with the EMC Directive

The European Union allows manufacturers to self-certify that their products comply with the EMC Directive. Alternately, manufacturers may base their compliance on a Technical Construction File (TCF) which is assessed by an EU-authorized Competent Body. GE Fanuc has elected the TCF approach. Compliance specifications are summarized by the EMC Emissions, EMC Immunity, and Power Supply sections found in Appendix A.

GE Fanuc has issued Declaration of Conformity (DoC) documents for each family of products, thereby indicating compliance with the CE Marking Directive (93/68/EEC). The DoC documents contain a list of all products, which are labeled with the CE mark. These DoC documents can be accessed through GE Fanuc Automation's World Wide Web site.

The following section specifies additional installation and application practices necessary to meet the EMC Directive for wiring that leaves the control cabinet and travels through a factory environment. Wiring leaving the cabinet may be exposed to interference sources corresponding to the standards and levels specified in Appendix A. The installation practices found in the individual product installation manuals must also be followed.

Grounding the Controls Enclosure

Locally applicable grounding safety regulations and machinery directives should be followed for providing a protective ground to earth. In addition, the following safety guidelines should be followed:

- Ground conductors should be as short and as large in size as possible. The conductors must always be large enough to carry the maximum short circuit current of the path being considered. Braided straps or ground cables (typically green insulation with a yellow tracer — AWG #12 [3.3 mm²] or larger) can be used to minimize resistance.
- The PLC equipment, other control equipment, and the machine should be interconnected to maintain a common earth ground reference, also called the machine chassis ground.
- Ground conductors should be connected in a tree fashion with branches routed to a central earth ground point. This ensures that no ground conductor carries current from any other branch. This method is shown in Figure 1-3.

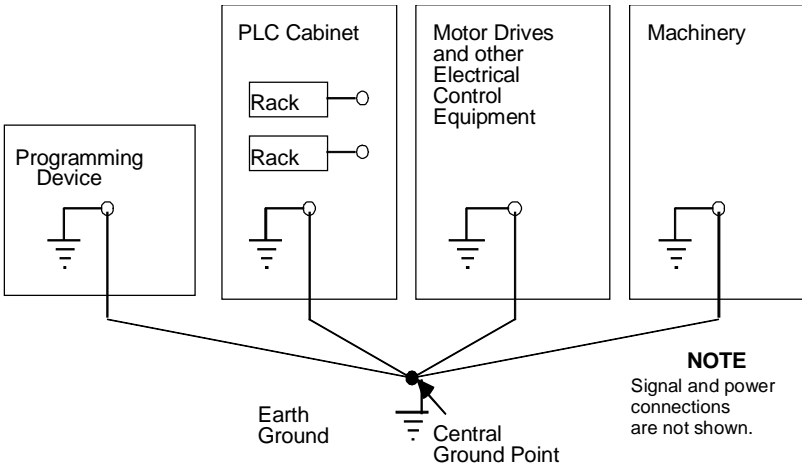

Figure 1-2. Recommended System Grounding

The EMC ground deals with the ability of the system to conduct interference energy transformed into a high frequency and high amplitude current to the machine chassis without causing secondary interference. The EMC ground requires the following:

- The EMC ground must be a low impedance, low inductance path to the machine chassis ground.
- The baseplate on which the PLC is mounted should be connected to the machine chassis ground by a wire with a 10:1 length-to-width ratio to provide a high frequency path. (A worst-case installation simulated for EMC testing used a 2 meter, 12 AWG wire.)

Cable Shield Clamping Assembly

A cable shield clamping assembly (IC697ACC736) is available to provide higher EMC immunity for shielded cables in severe industrial environments. This assembly provides a high frequency ground for shielded cables via a ground plate and six cable clamps. (A set of 12 additional cable clamps can be ordered—IC697ACC737.) Refer to Appendix B for detailed installation and usage information about the assembly. As an alternative, high frequency grounds for shields can be fabricated from suitable material. An example is shown below with the insulating cover of the cable stripped back.

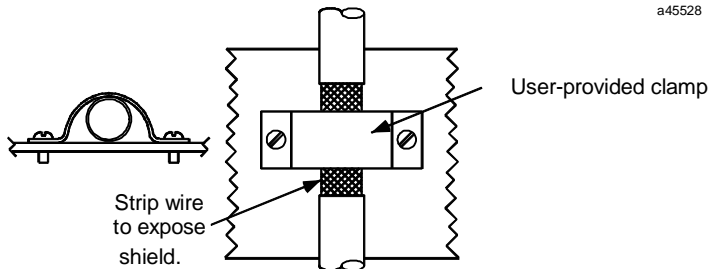

Figure 1-3. Alternative to Cable Shield Clamping Assembly

I/O Power Sources

All power sources needed by the PLC equipment for I/O (discrete and analog) must be appropriately conditioned to not exceed both the I/O EMC levels specified in Appendix A for IEC 1000-4-4 and the 1 kilovolt common mode and differential mode with 42Ω source impedance for IEC 1000-4-5.

All Analog Modules

All analog modules, including RTD and Thermocouple modules, must have shielded cable connections with the shield grounded at one end (at source).

Series 90-30 Products

General Installation Guidelines

In order to meet U.S., Canadian, Australian, and European regulations for Class A digital devices, all applicable products in the **Series 90-30** PLC product line have complied with EN55022 standard when installed as follows:

- An external ground wire (16 AWG [1.32mm²] of shortest possible length approx. 6 - 7" [15.24- 17.78cm]) must be wired from the Series 90-30 power supply safety ground wire terminal to the metal base plate. See Figure 1-1.

In order to meet U.S., Canadian, Australian, and European regulations for Class A digital devices, all applicable products in the **Series 90-30** PLC product line, *except those listed in Appendix D*, have complied with EN55022 standard when installed as follows:

- The PLC system must be mounted in a metal enclosure or the equivalent. All surfaces of the enclosure must be adequately grounded to adjacent surfaces to provide electrical conductivity. Wiring external to the enclosure must be routed in metal conduit or the equivalent. Using shielded cables and power line filtering, as detailed in Appendix C, is equivalent to using metal conduit.
- The conduit must be mounted to the enclosure using standard procedures and hardware to ensure electrical conductivity between the enclosure and conduit. The termination for the shielded cable alternative to conduit is detailed in Appendix C.

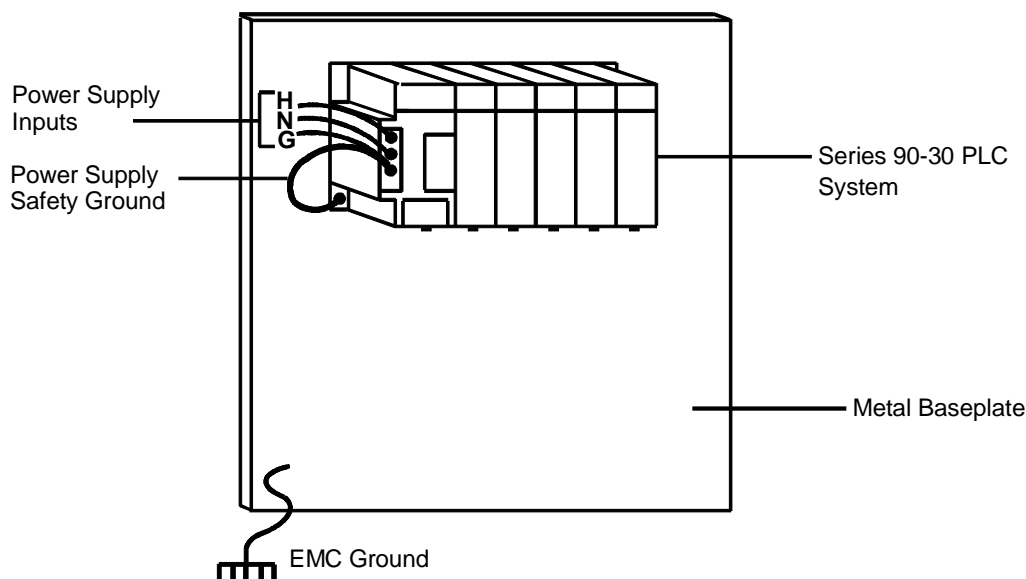

Figure 1-4. Installed PLC System

Safety and Reference Ground

The metal back of the baseplate is ground, when properly installed. Safety and reference ground connections should be made from one of the mounting tabs to earth ground using a minimum AWG #12 (3.3 mm²) wire and a ring terminal. The use of a nut and star washer for each wire on the ground connection lug is recommended to ensure adequate grounding.

Warning

The baseplate must be grounded to minimize electrical shock hazard, which may result in severe personal injury.

All baseplates grouped together in a Series 90-30 PLC system must have a common ground connection. This is especially important for baseplates that are not mounted in the same control cabinet.

The best way to provide proper ground connections is to ensure that the Series 90-30 PLC baseplate metal frame is directly connected to the control panel in which the baseplate or baseplates are mounted. This can be accomplished by connecting a ground strap from one of the ground lugs on either side of the baseplate to the control panel or cabinet following applicable electrical safety codes.

Additional Guidelines for Specific Components

The guidelines specified in this section must be followed in addition to the guidelines found in the general installation guidelines for the product line.

Expansion and Remote Cables

Custom length expansion and remote cables must be 100% shielded to meet the immunity levels specified in Appendix A. A 100%, or continuous, shield means that the braided cable shield is connected to the metal shell of the connector around the entire perimeter of the connector. This shielding provides a low impedance path to earth ground for any noise energy that is coupled onto the cable shield. Refer to the *Series 90-30 Installation Manual*, GFK-0356L or later, for details on cable construction.

IC693ALG392/442

In order to meet the IEC 1000-4-3 levels specified in Appendix A when an IC693ALG392 or IC693ALG442 module is installed in a control system, the Series 90-30 PLC system must be mounted in a metal enclosure.

IC693APU300

Shielded cable must be used for cables connecting to the IC693APU300 High Speed Counter. The shield for the cable must have a high frequency ground within 6 inches (15.24 cm) of the IC693APU300 module in order to meet the IEC 1000-4-4 levels specified in Appendix A. The cable's length is limited to 30 meters.

IC693APU301/302

The Axis Positioning Modules have two faceplate connectors, marked A and B, for User I/O. In order for Axis Positioning Modules IC693APU301 (version I or earlier) and IC693APU302 (version K or earlier) to meet the IEC 1000-4-4 levels specified in Appendix A, the shield wire must be connected directly to ground. To make this connection, disconnect the User I/O connector cable (IC693CBL311) drain wire from pin B12 (frame ground) of each I/O connector and directly connect it to ground with a 16 AWG (1.32 mm²) wire 8 inches (20.32 cm) maximum in length. Optional cables IC693CBL317 (3 m) and IC693CBL320 (1 m) are already modified to the above dimensions. The cable connected to the SNP port for downloading user programs must be less than 30 meters. Please refer to Appendix C of the APM User's Manual for the I/O connector cable specifications.

Axis Positioning Modules IC693APU301 (version J or later) and IC693APU302 (version H or later) do not require the cable connector to be disconnected. The standard user I/O cable (IC693CBL311 [3 m] or IC693CBL319 [1 m]) satisfies the IEC 1000-4-4 requirements. However, for best results, a high frequency ground (FANUC clamp) for the cable shield should be used. Optional cables IC693CBL317 (3 m) and IC693CBL320 (1 m) provide better noise suppression than the standard I/O cables without the high frequency ground.

IC693CMM321

When the RS485 port of the Ethernet module is used, in order to meet the IEC 1000-4-4 levels specified in Appendix A, a high frequency ground for the RS485 cable shield is required within 12 inches of the module. The shield conductor should remain continuous to the module, and insulation should be removed only at the grounding point. For more information, please refer to “Cable Shield Clamping Assembly” earlier in this chapter.

IC693CPU351

In order to meet the IEC 1000-4-4 levels specified in Appendix A, the ground wire and grounding bracket of the IC693CPU351 must be installed as outlined in the *Series 90-30 Installation Manual* (GFK-0356L or later). Optionally, the ground wire and a high frequency ground for the cable shield within 12 inches of the module may be used. The shield conductor should remain continuous to the module, and insulation should be removed only at the grounding point. For more information, please refer to “Cable Shield Clamping Assembly” on page earlier in this chapter.

IC693MCM001

In order to meet the IEC 1000-4-2 levels specified in Appendix A, when an IC693MCM001 module is installed in a control system, the Series 90-30 PLC system must be mounted in a metal enclosure. In order to meet EN55022 Group 1, Class A Radiated Emissions levels, the metal enclosure should provide a metal-on-metal connection around the door. In order to meet the IEC 1000-4-4 and IEC 1000-4-5 levels specified in Appendix A, the continuous shielded servo command cables should be clamped at both ends (at module and at servo) using a high-frequency ground. For more information, please refer to “Cable Shield Clamping Assembly” earlier in this chapter.

IC693MDL654

Conventional TTL wiring practices should be utilized when installing this module. For noise immunity reasons, I/O control lines connected to this module must be less than 30 meters in length (however, signal attenuation considerations will constrain practical wiring length to less than this maximum specification).

IC693PRG300

For installations in which the Hand-Held Programmer is permanently installed, the shielded cable to the Hand-Held Programmer must have a high frequency ground for the shield within 13” (33 cm) of the Hand-Held Programmer in order to meet the IEC 1000-4-4 levels specified in Appendix A. The shield on the cable must continue to the Hand-Held Programmer.

IC693PWR322/328

In order to meet EN55022 Group 1, Class A Radiated Emission levels, this module requires two small turns on the incoming DC power lines to be placed around a ferrite clamp (Steward Part #A2029-0A0 or ferrite with similar characteristics).

Series 90-70 Products

General Installation Guidelines

In order to meet U.S., Canadian, Australian, and European regulations for Class A digital devices, all applicable products in the **Series 90-70** PLC product line have complied with EN55022 standard when installed as follows:

- The PLC system must be mounted in a metal enclosure with a metal-on-metal connection around the door or the equivalent. All surfaces of the enclosure must be adequately grounded to adjacent surfaces to provide electrical conductivity. Wiring external to the enclosure must be routed in metal conduit or the equivalent. Using shielded cables and power line filtering, as detailed in Appendix C, is equivalent to using metal conduit.
- The additional safety ground wire provided with the Series 90-70 power supply must be wired from the Series 90-70 rack ground stud to the power supply safety ground wire terminal.
- The conduit must be mounted to the enclosure using standard procedures and hardware to ensure electrical conductivity between the enclosure and conduit. The termination for the shielded cable alternative to conduit is detailed in Appendix C.

Safety and Reference Ground

The metal back of the baseplate is ground, when properly installed. Safety and reference ground connections should be made from one of the mounting tabs to earth ground using a minimum AWG #12 (3.3 mm²) wire and a ring terminal. Use of a nut and star washer for each wire on the ground connection lug is recommended to ensure adequate grounding.

Warning

The baseplate must be grounded to minimize electrical shock hazard, which may result in severe personal injury.

All baseplates grouped together in a Series 90-70 PLC system must have a common ground connection. This is especially important for baseplates that are not mounted in the same control cabinet.

The best way to provide proper ground connections is to ensure that the Series 90-70 PLC baseplate metal frame is directly connected to the control panel in which the baseplate or baseplates are mounted. This can be accomplished by connecting a ground strap from one of the ground lugs on either side of the baseplate to the control panel or cabinet following applicable electrical safety codes.

Additional Guidelines for Specific Components

The guidelines specified in this section must be followed in addition to the guidelines found in the general installation guidelines for the product line.

IC697BEM741/742 and IC687BEM741/742

In order to meet IEC 1000-4-2 (8 kV Air), the communication ports (channels 1 and 2) of the FIP Bus Controller should be connected to the FIP network with an ITT Cannon FBC 115 434-2 or FBC 115 434-3 cable (or cable with a similar plastic connector shell); otherwise, the provided plastic connector cover and nylon screws should be used to cover the exposed metal connector of the FIP communication port.

IC697MCM001

In order to meet EN55022 Group 1, Class A Radiated Emissions levels, as an alternative to conduit, each shielded servo cable should have a ferrite located approximately 1–2 inches (2.54–5.08 cm) away from the port and a high frequency ground at the entrance to the enclosure. Also, as stated in *Power Mate I Connection Manual* (GFZ-62733), the continuous shielded servo cables should be clamped for proper grounding for compliance with immunity tests.

IC697MDL651

Conventional TTL wiring practices should be utilized when installing this module. For noise immunity reasons, I/O control lines connected to this module must be less than 30 meters in length (however, signal attenuation considerations will constrain practical wiring length to less than this maximum specification).

IC697PCM711/PCM712/CMM711/CMM712/ADC701

Continuous shielded cable must be used for cables connected to the ports on these modules in order to meet the IEC 1000-4-4 levels listed in Appendix A. The continuous shielded cable must have a high frequency ground within 18 inches (45.72 cm) of the module to pass the IEC 1000-4-6 levels listed in Appendix A. Continuous or 100% shielded means that the braided cable shield is connected to the metal shell of the connector around the entire perimeter of the connector. This shielding provides a low impedance path to frame ground for any noise energy that is coupled onto the cable shield.

Genius I/O Products

General Installation Guidelines

In order to meet U.S., Canadian, Australian, and European regulations for Class A digital devices, all applicable products in the **Genius** product line have complied with EN55022 standard when installed as follows:

- The system must be mounted in a metal enclosure or the equivalent. All surfaces of the enclosure must be adequately grounded to adjacent surfaces to provide electrical conductivity. Wiring external to the enclosure must be routed in metal conduit or the equivalent. Using shielded cables and power line filtering, as detailed in Appendix C, is equivalent to using metal conduit.
- The conduit must be mounted to the enclosure using standard procedures and hardware to ensure electrical conductivity between the enclosure and conduit. The termination for the shielded cable alternative to conduit is detailed in Appendix C.
- In order to meet IEC 1000-4-2 and IEC 1000-4-3 levels as specified in Appendix A, all components in a Genius I/O system must be mounted inside a metal enclosure.

Additional Guidelines for Specific Components

The guidelines specified in this section must be followed in addition to the guidelines found in the general installation guidelines for the product line.

IC660BBA023/103

In the presence of severe RF interference (IEC 1000-4-3), the thermocouple lines must be shielded to minimize any inaccuracies that the interference may cause and to meet compliance.

IC660ELB921/ELB922

When the length of the Genius communication cable from the PC Interface Module (PCIM) to the first Genius drop exceeds 30 meters, an external clamp on ferrites must be used. Fair-Rite Products Corporation ferrites, as shown in the following table, or equivalent parts may be used.

Fair-Rite Part No.	Max. Cable Diameter	Impedance (Ω) 25 MHz Minimum	Impedance (Ω) 25 MHz Minimum	Description
2643164251	.250"	130	275	core only
2643167251	.390"	110	225	core only
2643164151	.500"	125	250	core only
0199164251	.250"	—	—	case
0199167251	.390"	—	—	case
0199164151	.500"	—	—	case
0443194251	.250"	130	275	case and two ferrite parts
0443167251	.390"	110	225	case and two ferrite parts
0443164151	.500"	125	250	case and two ferrite parts

Field Control Products

General Installation Guidelines

In order to meet U.S., Canadian, Australian, and European regulations for Class A digital devices, all applicable products in the **Field Control** product line have complied with EN55022 standard when installed as follows:

- The Field Control product must be mounted on a conductive surface DIN rail. Refer to the *Field Control Distributed I/O and Control System Genius Bus Interface Unit User's Manual*, GFK-0825, for dimensions.
- The DIN rail must be mounted on a metallic surface (panel) that is grounded to earth.
- The DIN rail must be grounded to the metallic surface (panel) every 6 inches (15.24 cm) with screws and star washers.
- The safety ground wire (14 AWG [2.10 mm²]) for the Bus Interface Unit and the I/O bases must be a maximum of 4 inches (10.16 cm) in length to the panel.
- The panel ground wire (14 AWG [2.10 mm²]) for the auxiliary terminal strip for analog shields must be a maximum of 4 inches (10.16 cm) in length to the panel.

Genius Stations

The Genius Station (IC670GBI002 and IC670GBI102) has no specific installation guidelines to meet EN55022 Group 1, Class A Radiated Emission levels. The communication cable from one Bus Interface Unit to another may be any cable approved for use with the communication network. However, the communication cable from the controlling equipment to the Bus Interface Unit must be conditioned per the requirements of the controlling equipment. An example is shown in Figure 1-5 for a Genius Bus Interface Unit.

FIP Stations

IC670FBI002

The IC670FBI002 FIP BIU has no specific installation guidelines to meet EN55022 Group 1, Class A Radiated Emission levels. The communication cable from one Bus Interface Unit to another may be any cable approved for use with the communication network. However, the communication cable from the controlling equipment to the Bus Interface Unit must be conditioned per the requirements of the controlling equipment. An example is shown in Figure 1-5 for a Genius Bus Interface Unit.

IC670FBI102

In order to meet the requirements for CE mark approval, all components using the IC670FBI102 FIP Bus Interface Unit require the following:

- All components must be mounted in a metal enclosure or the equivalent. All surfaces of the enclosure must be adequately grounded to adjacent surfaces to provide electrical conductivity.
- EMC filter must be installed on the power supply lines.
- Ferrite core must be clamped around all discrete I/O lines in FIP Station.
- In order to pass IEC 1000-4-2, HF protection cover (metal cover) must be installed on the unused D-sub connector.

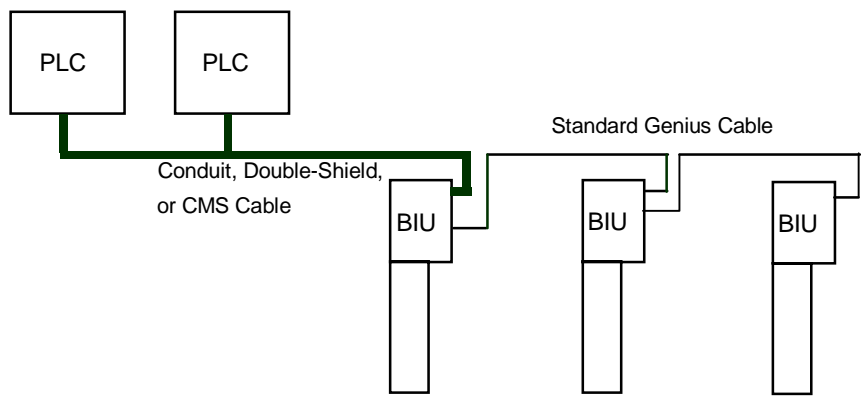

Figure 1-5. Communication Cable Requirements

Profibus Station

In order to meet EN55022 Group 1, Class A Radiated Emission levels, all components using the Profibus Station (IC670PBI001) require the following:

- All components must be mounted in a metal enclosure or the equivalent. All surfaces of the enclosure must be adequately grounded to adjacent surfaces to provide electrical conductivity. Wiring external to the enclosure must be routed in metal conduit or the equivalent. Using shielded cables and power line filtering, as detailed in Appendix C, is equivalent to using metal conduit.
- The conduit must be mounted to the enclosure using standard procedures and hardware to ensure electrical conductivity between the enclosure and the conduit. The termination for the shielded cable alternative to conduit is detailed in Appendix C.

Additional Guidelines for Specific Components

The guidelines specified in this section must be followed in addition to the guidelines found in the general installation guidelines for the product line.

IC670ALG320

The user supply input must be provided from a power supply in the cabinet, conditioned by a 30 volt varistor, or wired with a twisted pair shielded cable grounded at the source in order to not exceed 1 kilovolt common mode and differential mode with 42Ω source impedance for IEC 1000-4-5.

VersaMax Products

General Installation Guidelines

In order to meet U.S., Canadian, Australian, and European regulations for Class A digital devices, all applicable products in the VersaMax product line have complied with EN55022 standard when installed as follows:

- The VersaMax product must be mounted on a conductive surface DIN rail. Refer to the VersaMax User's Manuals, GFK-1503, GFK-1504, GFK-1535.
- The DIN rail must be mounted on a metallic surface (panel) that is grounded to earth.
- The DIN rail must be grounded to the metallic surface (panel) every 6 inches (15.24 cm) with screws and star washers.
- The safety ground wire (14 AWG [2.10 mm²]) for the power supply module must be a maximum of 4 inches (10.16 cm) in length to the panel. Refer to GFK-1515 or GFK-1516.

IC200MDD841

To meet the IEC 100044 levels specified in Appendix A, shielded cable properly terminated to earth ground must be used to connect the count inputs of the IC200MDD841 High Speed Counter module .

IC200PWR001/002

In order to meet IEC1000-4-5 levels specified in Appendix A, external 32V MOV (metal oxide varistor) suppression is required from both the positive and negative input to frame ground or at the power line input of a system enclosure. A Harris V36ZA80 MOV, rated 160 joules should be sufficient.

IC200PWR101/102

In order to meet IEC1000-4-5 levels specified in Appendix A, external 32V MOV suppression is required from both the positive and negative input to frame ground or at the power line input of a system enclosure. A Harris V36ZA80 MOV, rated 160 joules should be sufficient.

DataPanel Products

IC752DFT100/101

If communications cable or DC power lines exceed 10 meters in length, then an earth-ground connection should be made to pin 3 of the DC power input terminal.

Low Voltage Directive

The Low Voltage Directive applies to products operating between 50 and 1000 VAC or 75 and 1500 VDC. The emphasis of the Low Voltage Directive is on safety.

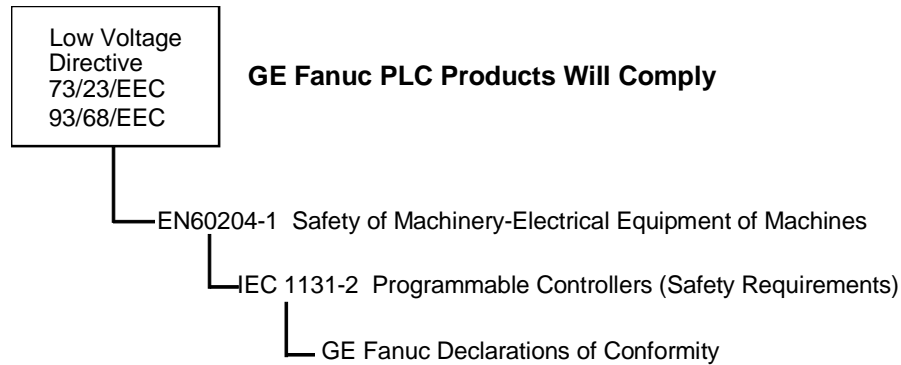

Figure 1-6. GE Fanuc’s path to comply with the Low Voltage Directive

The following sections specify installation and application practices necessary to meet the Low Voltage Directive.

Installation Requirements

For compliance to the Low Voltage Directive, Series 90-30, Series 90-70, Field Control, VersaMax and Genius systems and their components are considered open equipment [i.e. live electrical parts may be accessible to users] and must be installed in an enclosure.

IEC 1131-2:1991 (sect. 4.2, item 2) states: “Open equipment is not required to meet IP2X requirement.....Opening of the enclosure shall only be possible by means of a key or tool.”

In addition, refer to the installation manual for your system and follow the guidelines for mounting, spacing, and, if applicable, shielding the devices in your system.

Locally applicable grounding safety regulations and machinery directives should be followed for providing a protective ground to earth. Refer to “Grounding the Controls Enclosure” as well as the general installation guidelines for Series 90-30, Series 90-70, Genius I/O, VersaMax, and Field Control products found in the EMC Directive section of this manual for additional safety guidelines related to earth grounding.

Note

Care should be taken regarding installation wiring to ensure proper connections and to protect against equipment damage or misoperation.

In addition to observing the system grounding procedures recommended for your system, periodic inspections of the ground connections should be performed to ensure that the system remains properly grounded.

Series 90-30 Products

To avoid possible misrouting of wiring to I/O modules, the following is recommended:

- Label all wires to and from I/O devices. Record circuit identification numbers or other pertinent data on the inserts which go in the module's faceplate door.
- Wires should be dressed so that each field I/O connector is fixed relative to its respective module.

Handling Modules

Use the procedures found in the installation manual of your system for the safe and proper removal of PLC modules.

Warning

Exercise care when working around operating PLC equipment — devices may become very hot and could cause injury.

Machinery Directive

The Machinery Directive focuses on the safe operation of the entire machine and is the responsibility of the machine manufacturer.

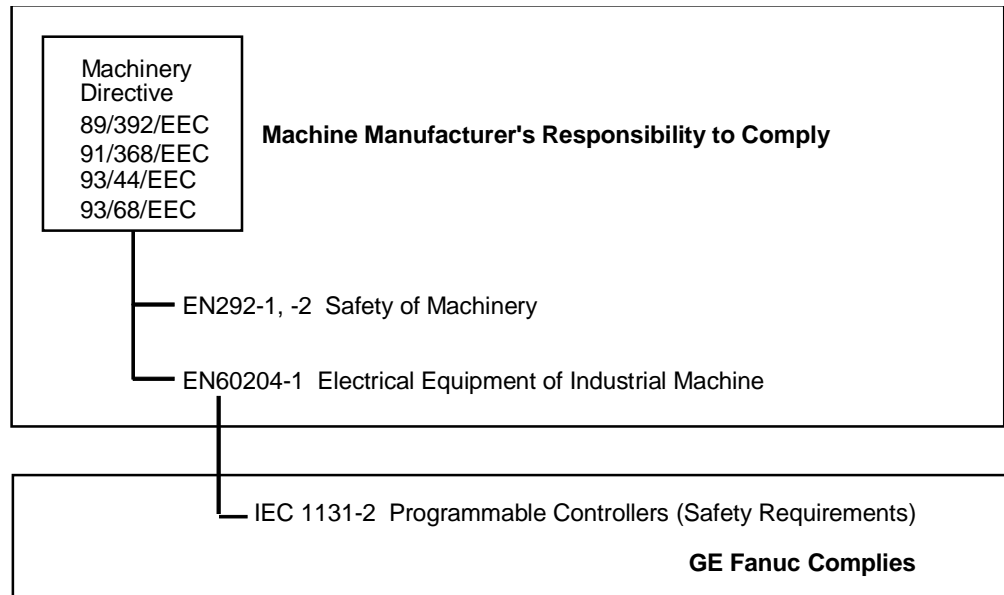

Figure 1-7. GE Fanuc’s path for supporting machine manufacturer’s compliance with the Machinery Directive

When applied in accordance with EN60204-1 (Electrical Equipment of Industrial Machines) and GE Fanuc installation instructions, GE Fanuc PLC products allow a machine manufacturer to comply with the electrical safety requirements of the Machinery Directive. Other requirements of the Machinery Directive involving items such as displays, languages, instructions, Emergency Stop functions, machine operation, protective guards, and interlocks are the responsibility of the machine manufacturer.

The specific requirements of EN60204-1, IEC 1131-2, and GE Fanuc installation instructions are as follows:

- Compliance with EN292-1 and EN292-2 (Safety of Machinery) as well as EN60204/IEC204 (Electrical Equipment of Industrial Machines) must be observed during the design phase.
- The PLC products must be packaged within an IP54 or higher degree of protection enclosure.
- Negative logic input and output modules cannot be used. (Exception: With safety agency approval, these devices may be used in safety system “H” configurations.)
- The PLC power supply must be supplied through an IEC-rated isolation transformer.
- Power supply to the PLC must be controlled to ensure that it does not exceed overvoltage category II per EN60204-1 (IEC 240).
- Cable shielding and grounding are the responsibility of the machine builder. GE Fanuc’s installation instructions and guidelines must be followed.

- Installation, operation, and maintenance instructions in the language of the user country are the responsibility of the machine builder.

Appendix A includes a summary of existing agency approvals issued for GE Fanuc PLC products. In addition to this summary, selected Series 90-70 and Genius modules have been approved by TÜV for compliance with DIN VDE 0116 and class 5 of DIN VDE 0801 for use in redundant safety system applications. These safety agency approvals demonstrate that GE Fanuc PLC products meet essential safety requirements.

GE Fanuc PLC products support the following European languages:

- Series 90-30 and Series 90-70 manuals: English now (German and French to be added in a future release)
- Genius manuals: English
- Series 90-30 Logicmaster: English, German, French (Spanish to be added in the next release)
- Series 90-70 Logicmaster: English, French (German to be added in a future release)
- Genius Hand-Held Monitor: English, German, French, Italian
- Field Control manuals: English
- VersaMax manuals: English

Safety-Related Guidelines for Users of GE Fanuc PLC Products to be Installed in the European Union

Introduction

This chapter provides a description of safety-related guidelines for the installation of PLC systems. It is assumed that personnel who install, operate, and maintain automation systems which include GE Fanuc products are trained and qualified to perform those functions. This chapter specifically provides safety-related guidelines for products to be installed in the European Union.

1. **General:**

GE Fanuc product manuals provide information required for the intended use of GE Fanuc products. The product manuals are written for technically qualified personnel such as engineers, programmers, or maintenance specialists who have been specifically trained and are experienced in the field of automation control. Such personnel must possess the knowledge to correctly interpret and apply the safety guidelines provided in GE Fanuc product manuals. Should you require further information or face special problems that have not been dealt with in sufficient detail in the product manuals, please contact your local GE Fanuc sales or service office or GE Fanuc authorized distributor.

2. **Qualified Personnel:**

Only qualified personnel should be allowed to specify, apply, install, operate, maintain, or perform any other function related to the products described in the product manuals. Examples of such qualified persons are defined as follows:

- System application and design engineers who are familiar with the safety concepts of automation equipment.
- Installation, startup, and service personnel who are trained to install and maintain such automation equipment.
- Operating personnel trained to operate automation equipment and trained on the specific safety issues and requirements of the particular equipment.

3. *Proper Usage:*

The equipment/system or the system components may only be used as described in the product manuals. GE Fanuc PLC products have been developed, manufactured, tested, and the documentation compiled in keeping with the relevant safety standards. Handling instructions and safety guidelines described for planning, installation, proper operation and maintenance must be followed to ensure safe application and use of the products.

4. *Guidelines for the Application Planning and Installation of the Product:*

GE Fanuc PLC products generally form a part of larger systems or installations. These guidelines are intended to help integrate GE Fanuc PLC products into systems and installations without constituting a source of danger. The following precautions must be followed:

- Compliance with EN292-1 and EN292-2 (Safety of Machinery) as well as EN60204/IEC204 (Electrical Equipment of Industrial Machines) must be observed during the design phase.
- Opening the housing or the protective cover exposes certain parts of this equipment/system which could have a dangerously high voltage level.
- Only qualified personnel should be allowed access to this equipment/system.
- These persons must be knowledgeable of potential sources of danger and maintenance measures as set out in the product manuals.
- Strictly adhere to applicable safety and accident prevention rules and regulations.
- A suitable isolating switch or fuses must be provided in the building wiring system. The equipment must be connected to a protective ground (PE) conductor.
- For equipment or systems with a fixed connecting cable but no isolating switch which disconnects all poles, a power socket with the grounding pin must be installed.
- Before switching on the equipment, make sure that the voltage range setting on the equipment corresponds to the local power system voltage.
- In the case of equipment operating on 24 V DC, make sure that proper electrical isolation is provided between the main supply and the 24 V supply. Use only power supplies that meet EN60204 (IEC204) requirements.
- PLC AC power supply must be supplied through an IEC-rated isolation transformer.
- Power supply to the PLC must be controlled not to exceed overvoltage category II per EN60204-1 (IEC204).
- Fluctuations or deviations of the new power supply voltage from the rated value must not exceed the tolerances specified in the technical specifications. Otherwise, functional failures or dangerous conditions can occur in the electronic modules/equipment.
- Emergency tripping devices in accordance with EN60204/IEC204 must be effective in all operating modes of the automation equipment. Resetting the emergency off device must not result in any uncontrolled or undefined restart of the equipment.
- Automation equipment and its operating elements must be installed in such a manner as to prevent unintentional operation.

-
- Suitable measurements must be taken to make sure that operating sequences interrupted by a voltage dip or power supply failure resume proper operation when the power supply is restored. Care must be taken to ensure that dangerous operating conditions do not occur even momentarily. If necessary, the equipment must be forced into the “emergency off” state.
 - Negative Logic Input and Output Modules cannot be used. (Exception: With safety agency approval (Such as TÜV on GMR Systems), these devices may be used in safety system “H” configurations).
 - Cable shielding and grounding are the responsibility of the machine builder. GE Fanuc’s installation instructions and guidelines must be followed.
 - Install the power supply and signal cables in such a manner as to prevent inductive and capacitive interference voltages from affecting the automation functions.
 - Measures must be taken when interfacing the inputs and outputs of the automation equipment to prevent an undefined state from being assumed in the case of a wire break in the signal lines.

Appendix

A

Product Agency Approvals, Standards, and General Specifications

The products supplied by GE Fanuc are global products which are designed and manufactured with ISO9001 quality assurance for application in industrial environments throughout the world. They should be installed and used in conformance with product specific guidelines as well as the following agency approvals, standards and general specifications:

AGENCY APPROVALS OVERVIEW ¹		<i>Comments</i>
Quality Assurance in Design/Development, Production, Installation, & Servicing	ISO9001	Certification ⁴ by BSI Quality Assurance
Safety for Industrial Control Equipment	UL508	Certification by Underwriters Laboratories
	C-UL⁵, CSA22.2, or 142-M1987	Certification by Underwriters Laboratories [C-UL ⁵] or Canadian Standards Association for selected Series 90, Genius, VersaMax, and Field Control modules
Safety for Hazardous Locations Class I, Div II, A, B, C, D	UL1604 with C-UL⁵	Certification by Underwriters Laboratory for Versa Max, Field Control, and selected Series 90 and Genius modules
	FM3611	Certification by Factory Mutual for selected Genius and Series 90-70 modules
	CSA22.2, 213-M1987	Certification by Canadian Standards Association for selected Genius modules
Safety for Hazardous Locations Class I, Zone 2, A, B, C, D	CENELEC prEN50021	Certification by DEMKO through Underwriters Laboratory for selected Series 90-30 and Field Control modules, and VersaMax products
	UL2279 IEC 79-15	Certification by Underwriters Laboratory for VersaMax products, and selected Series 90-30 and Field Control modules
European EMC and Low Voltage Directives	CE Mark	Certification by Competent Body for EMC Directive for selected modules

STANDARDS OVERVIEW^{2, 4}		<i>Conditions</i>
ENVIRONMENTAL		
Vibration	IEC68-2-6	1G @57-150Hz, 0.006in p-p @10-57Hz
Shock	IEC68-2-27	15G, 11ms
Operating Temperature ³		0°C to 60°C: Series 90 [inlet], Genius [ambient], VersaMax [ambient] 0°C to 55°C: Field Control [ambient]
Storage Temperature		-40°C to +85°C
Humidity		5% to 95%, non-condensing
Enclosure Protection	IEC529	Steel cabinet per IP54: protection from dust & splashing water
EMC EMISSIONS		
Radiated, Conducted	CISPR 11/EN 55011 CISPR 22/EN 55022 47 CFR 15	“Industrial Scientific & Medical Equipment” (Group 1, Class A) “Information Technology Equipment” (Class A) referred to as FCC part 15, “Radio Devices” (Class A)
EMC IMMUNITY		[applies to CE Marked modules]
Electrostatic Discharge	EN 61000-4-2*	8KV Air, 4KV Contact
RF Susceptibility	EN 61000-4-3*	10V _{rms} /m, 80Mhz to 1000Mhz, 80% AM
	ENV 50140/ ENV 50204	VersaMax: All power supply, I/O, and communication modules
Fast Transient Burst	EN 61000-4-4*	2KV: power supplies, 1KV: I/O, communication
Surge Withstand	ANSI/IEEE C37.90a	Damped Oscillatory Wave: 2.5KV: power supplies, I/O [12V—240V]
	IEC255-4	Damped Oscillatory Wave: Class II, power supplies, I/O [12V—240V]
	EN 61000-4-5*	Field Control and VersaMax: 2 kV cm(P/S); 1 kV cm (I/O) VersaMax: All power supply, I/O, and communication modules
Conducted RF	EN 61000-4-6*	10V _{rms} , 0.15 to 80Mhz, 80%AM: comm. modules w/ cables >30m VersaMax: All power supply, I/O, and communication modules
ISOLATION		
Dielectric Withstand	UL508, UL840, IEC664	1.5KV for modules rated from 51v to 250v
POWER SUPPLY		
Input Dips, Variations	EN 61000-4-11*	During Operation: Dips to 30% and 100%, Variation for AC ±10%, Variation for DC ±20%

* EN 61000-4-x series of tests are technically equivalent to the IEC 1000-4-x and IEC 801-x series.

- Note 1:* Module specific approvals are listed on the GE Fanuc Electronic Bulletin Board Service [BBS]. The BBS can be reached at 804-978-5458 with the following modem settings: 14400 baud, 8 data bits, 1 parity bit, no stop bits. After accessing the BBS, select the BBS File area (*PLC:AGENCY STATUS*) and the file (*AGENSTDS.XLS*).
- Note 2:* Refer to module specific data sheets & installation guidelines in the following publications:
GFK-0600, *Series 90-70 PLC Data Sheets Manual*; GFK-0262, *Series 90-70 PLC Installation Manual*;
GFK-0356, *Series 90-30 PLC Installation Manual*; GFK-0898, *Series 90-30 I/O Specifications Manual*;
GEK-90486-1, *Genius I/O System User's Manual*; GEK-90486-2, *Genius I/O Discrete and Analog Blocks User's Manual*;
GFK-0825, *Field Control Distributed I/O and Control System - Genius Bus Interface Unit User's Manual*;
GFK-0826, *Field Control Distributed I/O and Control System - I/O Module's User's Manual*;
GFK-1179, *Installation Requirements for Conformance to Standards*; GFK-1503, *VersaMax System PLC Reference Manual*;
GFK-1504, *VersaMax System I/O and Option Modules*; GFK-1535, *VersaMax System Network Communications User's Manual*.
- Note 3:* Selected modules may be derated.
- Note 4:* Applies to GE Fanuc products designed and built in Charlottesville.
- Note 5:* Modules comply with applicable CSA Standards as evaluated by UL. The C-UL mark is accepted throughout Canada.

®Genius is a registered trademark of GE Fanuc Automation North America, Inc.

™Series 90, VersaMax, and Field Control are trademarks of GE Fanuc Automation North America, Inc.

This Appendix describes the Cable Shield Clamping Assembly for use with Series 90-30 and Series 90-70 Programmable Logic Controllers that are installed in severe industrial environments and must meet the requirements for higher EMC immunity.

Features

The Cable Shield Clamping Assembly features the following:

- Provides for higher EMC (Electromagnetic Compatibility) immunity for shielded cables
- Use for installations in severe industrial environments
- Use with all Series 90-30 and Series 90-70 PLC products
- Easy to assemble
- Mounts on panel, rack enclosure, or directly onto a Series 90-70 PLC rack

Functions

The Cable Shield Clamping Assembly, IC697ACC736, contains the parts necessary for providing higher EMC immunity for shielded cables in PLCs installed in severe industrial environments.

The Cable Shield Clamping Assembly must be used in severe industrial environments to provide higher EMC immunity for shielded cables. Shield grounding is accomplished using the ground plate and cable clamps provided in the kit.

The Cable Shield Clamping Assembly package includes:

- One ground plate
- Six cable clamps
- Four #6 self-tapping screws

Outline Drawing of Mounting Plate

Figure B-1 is an outline drawing of the mounting plate showing dimensions required for mounting. The figure also shows a cable clamp.

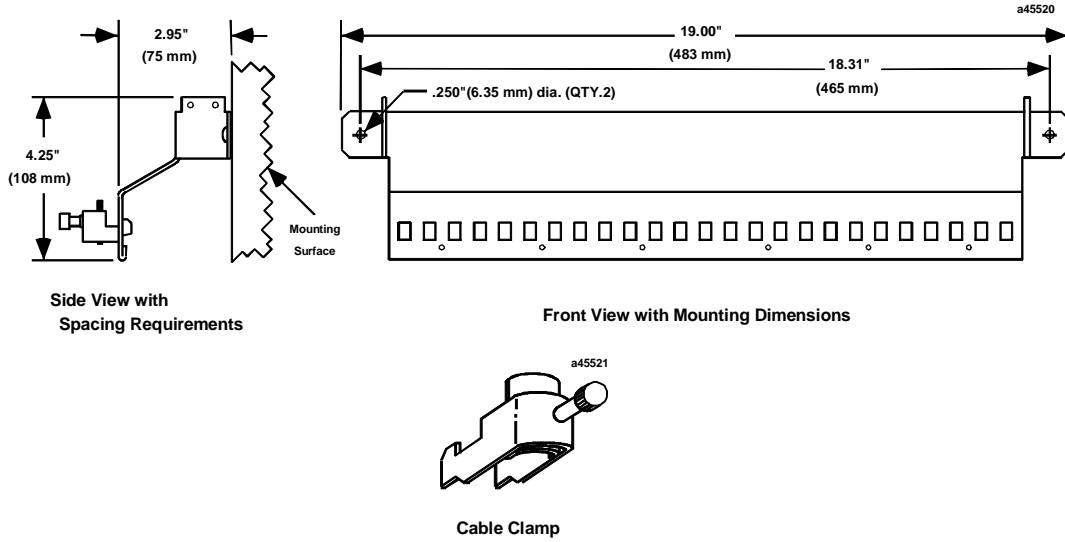

Side View with Spacing Requirements

Front View with Mounting Dimensions

Cable Clamp

(Six cable clamps included with assembly.)

* Additional cable clamps available (12 per package), catalog number IC697ACC737.

Figure B-1. Ground Plate Outline, Mounting Dimensions, and Cable Clamp

Installing the Assembly

The ground plate should be mounted near the PLC rack for both Series 90-70 and Series 90-30 PLC installations. The cable clamp provides mechanical relief as well as electrical grounding. A typical installation is shown in Figure B-2 below. Figure B-5 shows the Cable Clamp Assembly installed on a Series 90-70 PLC rack.

The cable clamp attaches to the ground plate by sliding it into two adjacent slots at the selected location for the cable. The cable is inserted between the ground plate and the cable clamp after removing the required section of the cable's outer cover. Tighten the cable clamp by turning the thumbscrew clockwise. *Do not over-tighten the thumbscrew— hand-tighten or tighten lightly with a tool.*

Note

If you are installing the ground plate on a painted surface, the paint must be removed where the ground plate is to be mounted to ensure a good ground connection between the plate and mounting surface.

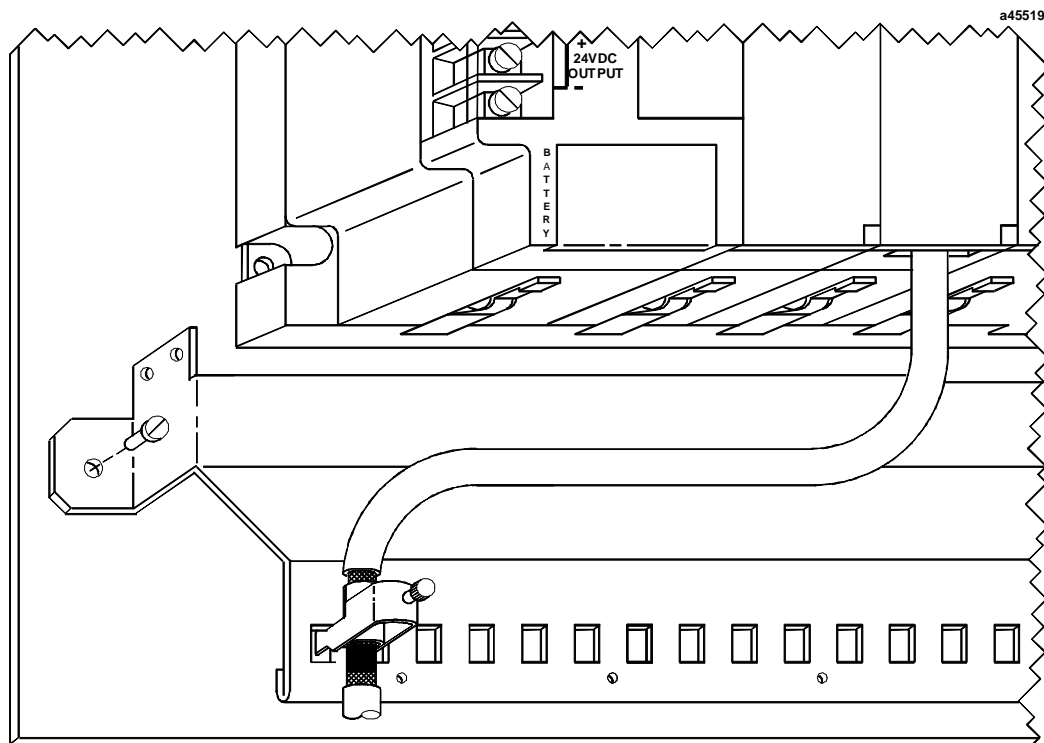

Figure B-2. Example of Cable Shield Clamping Assembly Installation

Maximum and Minimum Diameter Cable

The maximum diameter cable that can be used with the cable clamp is 0.51 inches (13mm) as shown below in Figure B-3. Minimum cable diameter that can be used with the clamp is 0.24 inches (6mm). Multiple cables can be placed in the clamp if the cable diameter is smaller than the minimum.

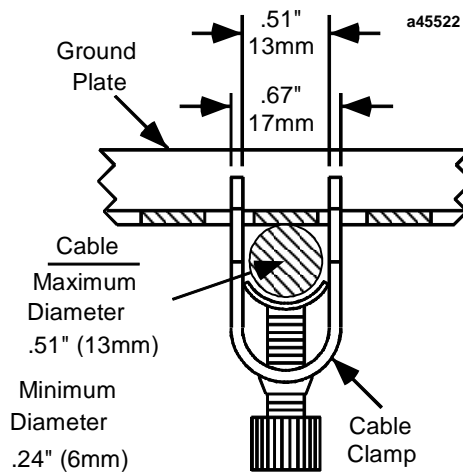

Figure B-3. Cross Section of Cable Secured by Clamp

Removing Cable Cover

The insulating cover on the shielded cable must be removed to allow maximum contact between the cable shield and the cable clamp as shown in Figure B-4.

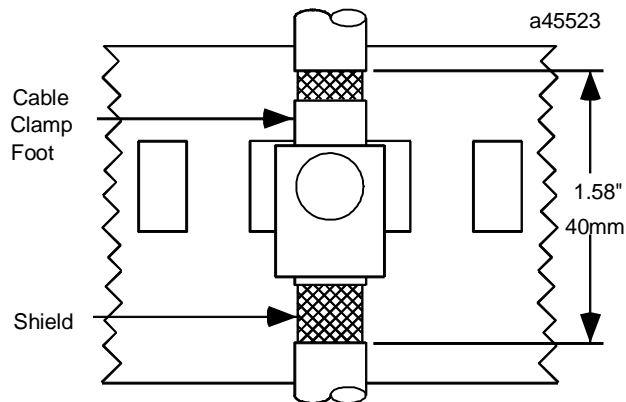

Figure B-4. Clamped Cable with Exposed Shield

Mounting on a Series 90-70 PLC Rack

In addition to mounting to a flat surface near the PLC system, the Cable Shield Clamping Assembly can be optionally attached directly to a Series 90–70 PLC rack as shown below. For compatibility, the following versions of racks are required for the Cable Shield Clamping Assembly:

- IC697CHS790E, or later version
- IC697CHS791E, or later version
- IC697CHS782C, or later version
- IC697CHS783C, or later version

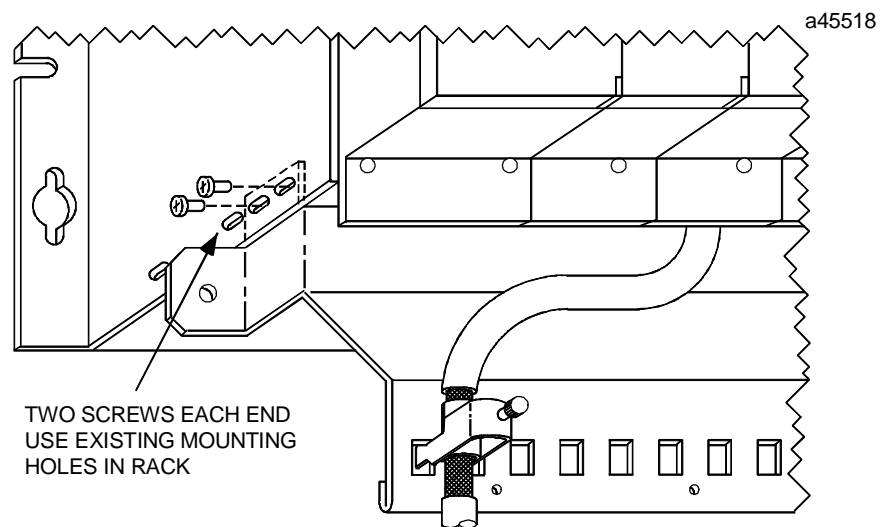

Figure B-5. Cable Shield Clamping Assembly Mounted on a Series 90-70 PLC Rack

This appendix describes the installation requirements for using shielded cable as an alternative to metal conduit for meeting radiated emissions requirements (EN55022, 47CFR15). The following practices could be used in place of conduit for systems or cables that require conduit or the equivalent.

Communication Cables

All communication lines should be double-shielded. The outside braided shield (85% coverage) must be terminated at the entrance to the enclosure and not continue within the enclosure. The inside shield should be left intact since it shields the communication line from noise within the enclosure and is terminated to the connector shell. The outside shield is classified as an RF shield and should be insulated from the inside shield.

Another alternative to double-shielded cable for Genius bus communications is Eupen* CMS cable, equivalent Genius cables with an RF-absorptive material outer coating. The shield should be terminated per standard Genius wiring guidelines.

*Telephone: 32 87 55 47 71 (Europe), 908-919-1100 (U.S.A.)

I/O Cables

All I/O lines leaving the enclosure must have at least 85% braided shield coverage terminated at the entrance to the enclosure. This 85% RF shield should not continue into the enclosure. Eighty-five percent braided shield is a standard cable available with various wire sizes and quantities from many cable manufacturers.

Analog/High Speed Cables

Analog or high speed lines, which require shielded cable for immunity, should be double-shielded. The outside braided shield should be terminated at the entrance to the enclosure and not continue within the enclosure. The inside shield should be terminated per standard installation instructions. The outside shield is classified as an RF shield and should be insulated from the inside shield.

Power Input to Enclosure

An alternative to shielded input cables is to utilize RF filters to minimize the noise coupled back onto the power supply inputs. If RF filters are used, then unshielded wires may be used inside and outside the enclosure.

AC Power Input RF Filter

- Common mode/Differential mode line filter
- Effective range between 30–300 megahertz
- Leakage current <0.8 milliampere
- Insertion loss >30 decibels @ 30 megahertz, >20 decibels @ 100 megahertz, >15 decibels @ 300 megahertz

DC Power Input RF Filter

- Feed-through, π type EMI ceramic filter
- Capacitance: 1500 picofarads (minimum)
- WVDC: 100 volts
- Current rating: As needed for application
- Insertion Loss: >50 decibels @ 100 megahertz

Shield Termination

Termination of RF shields is extremely important in the reduction of RF emissions. The RF shields should be terminated at the entrance to the enclosure with a 360 degree contact between the shield and the enclosure wall.

Compression Connectors

Compression connectors are standard hardware available for the termination of conduit. The diameter of the connectors is not of significant importance other than to make sure the wires can actually fit through them. The compression connector provides a metal ring for shield termination and compression.

The following figure shows an unshielded I/O cable with a single shield (side view):

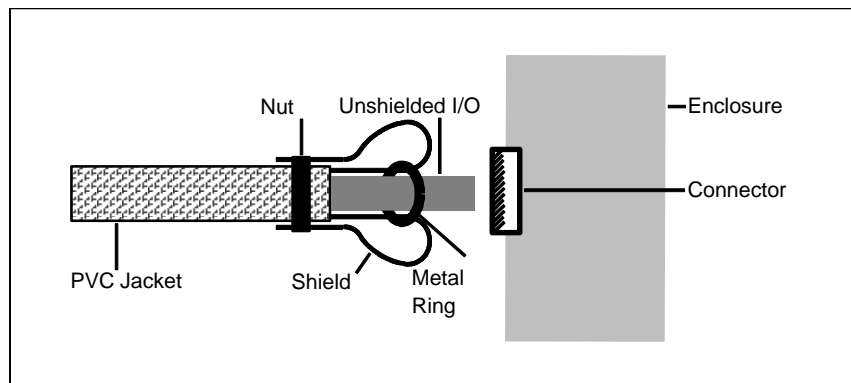

Figure C-1. Unshielded I/O Cable with a Single Shield

The following figure shows multiple communication/high speed cables that share a single RF shield (side view):

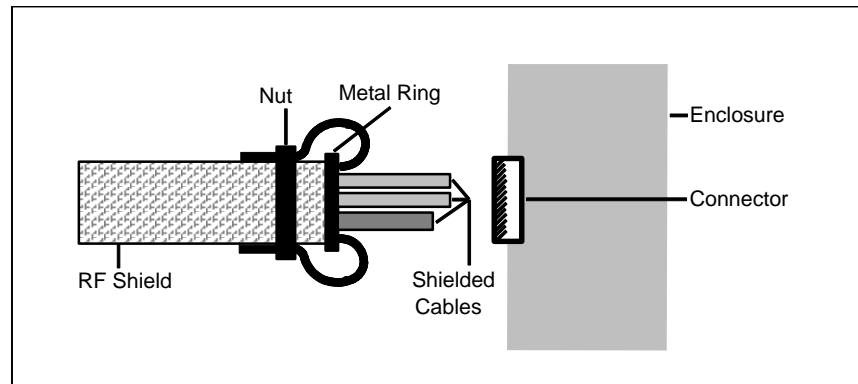

Figure C-2. Communication Cables Sharing an RF Shield

Specialty Shielded Cable Vendors

Eupen specializes in RF-absorptive material outer coating cables (CMS cables). Ask for equivalent Genius cables.

Glenair, Inc. specializes in convoluted tubing (Series 72 & 74) and in flexible metal-core conduit (Series 75). They also carry various kinds of shield termination connectors.

Zippertubing Co. specializes in after installation zip-on shielding where different types of shielding can be selected. Recommended types of shielding are SHN-3, SH1, and SH3 to provide 85% coverage.

Appendix

D

Radiated Emissions Compliant Products

The following list of products have been tested and found to be in compliance with FCC, European Norme and CISPR standards for radiated emissions as defined in Appendix A without being installed in a metal enclosure and external wiring being routed in metal conduit. The product catalog numbers with suffixes are listed below to indicate the module revision at which compliance was obtained. All subsequent revisions shall also comply.

Although these products do not require installation in a metal enclosure, they still must be installed in an enclosure with IP54 or greater rating to meet the EMC (Low Voltage Directive) and UL requirements for safety since these PLC products are considered to be open equipment (see “Low Voltage Directive” on page 1-16).

Catalog #	Suffix
IC693ACC300	A
IC693ALG221	B
IC693ALG222	A
IC693BEM331	E
IC693CHS391	J
IC693CHS397	G
IC693CHS398	E
IC693CMM302	K
IC693CPU331	AA
IC693CPU350	AA
IC693CPU360	AA
IC693CPU363	AA
IC693CPU364	AA
IC693MDL634	C
IC693MDL645	B
IC693MDL646	B

Catalog #	Suffix
IC693MDL655	C
IC693MDL730	C
IC693MDL731	C
IC693MDL740	C
IC693MDL741	A
IC693MDL742	A
IC693MDL753	C
IC693MDL931	A
IC693MDL940	A
IC693PRG300	E
IC693PWR321	S
IC693PWR322*	E
IC693PWR328*	A
IC693PWR330	B
IC693PWR331	A

* In order to meet EN 55022, Group 1 , Class A Radiated Emission levels, this module requires two small turns on the incoming DC power lines to be placed around a ferrite clamp (Steward Part # A2029-0A0 or ferrite with similar characteristics).

Appendix

E

Industrial Exemption Products

The following list of products have taken the Industrial Exemption according to 47CFR15.

PRODUCT FAMILY	CATALOG NUMBER
Micro Greyline	524, 524-/B, 524-/4X, 524-B/4X 525, 525-/B, 525-/4X, 525-B/4X 1024, 1024-/B, 1024-/4X, 1024-B/4X 1025, 1025-/B, 1025-/4X, 1025-B/4X
Operator Workstation	2024, 2024-128-C, 2024-230, 2024-LV 2025, 2025-128-C, 2025-LV 2224, 2225, 2225-LV
Monitors	CRTXXXXXC1A, CRTXXXXXC2A, CRTXXXXXC3A, CRTXXXXXC5A IAT-CRT-C1A
QuickPanel	QPI21100S2P, QPI21100S2P/B, QPI21100S2P/CTC, QPI21100S2P/SFM QPI2D100C2P, QPI2D100E2P QPI2D100L2P/B, QPI2D100L2P/ETL QPI2D100S2P, QPI2D100S2P/B, QPI2D100S2P/CTC QPI-ABR-002, QPI-GEG-201, QPI-MBP-201 QPJ2D100L2P, QPJ2D100L2P/B, QPJ2D100L2P/CTC, QPJ2D100L2P/S QPJ2D100S2P, QPJ2D100S2P/B, QPJ2D100S2P/CTC, QPJ2D100S2P/ETL QPJ-ABR-201/RDP, QPJ-GEG-201, QPJ-MBP-201 QPK2D100L2P, QPK2D100L2P/B, QPK2D100S2P
Smart Panel	SP-KC-01, SP-KC-02, SP-KTC-01
	TCS100-11001S, TCS100-43013S, TCS100-44012S, TCS100-44013S, TCS100-44112S, TCS110-44013S, TCS120-43013S, TCS150-43013S, TCS150-43103S, TCS150-44012S TCS-CRT-S01, TCS-CRT-V6A, TCS-CRT-V6T

A

- Analog/high speed cables, C-1
- Application planning and installation, 2-2
- Approvals, standards, and specifications, A-1
 - Radiated emissions compliant products, D-1, E-1
- Australian regulations, 1-1

C

- Cable shield clamping assembly
 - description, 1-6
 - features, B-1
 - installing, B-3
- Cables
 - analog/high speed, C-1
 - communication, C-1
 - I/O, C-1
 - power input to enclosure, C-1
 - shield termination, C-2
- Canadian regulations, 1-1
- Communication cables, C-1

E

- EMC directive, 1-4
- European Union directives, 1-3

F

- FCC notice, 1-1

G

- General installation guidelines
 - Field Control products, 1-13
 - Genius I/O products, 1-12
 - Series 90-30 products, 1-6
 - Series 90-70 products, 1-10
 - VersaMax products, 1-15
- Ground connections
 - Series 90-30 products, 1-7
 - Series 90-70 products, 1-10
- Grounding the controls enclosure, 1-5

I

- I/O cables, C-1
- I/O power sources, 1-6
- Industrial exemption
 - U.S. and Canadian Installations, 1-2
- Installation requirements
 - Field Control, 1-13, 1-15
 - Genius I/O, 1-12

- Series 90-30 PLC, 1-6
- Series 90-70 PLC, 1-10

L

- Low voltage directive, 1-16

M

- Machinery directive, 1-18
- Mounting plate, B-2

P

- Power input to enclosure, C-1
- Proper usage, 2-2

Q

- Qualified Personnel, 2-1

R

- Radiated emissions compliant products, D-1, E-1
- RFI standards, 1-1

S

- Safety-related guidelines, 2-1
- Shield termination, C-2
- Specialty shielded cable vendors, C-3

U

- U.S. regulations, 1-1

V

- Verification
 - U.S. and Canadian Installations, 1-2