

GFK-2441
New In Stock!
GE Fanuc Manuals

<http://www.pdfsupply.com/automation/ge-fanuc-manuals/rx3i-plc/GFK-2441>

rx3i-plc
1-919-535-3180

PACSystems RX3i High-Speed Counter Modules Manual,

www.pdfsupply.com

Email: sales@pdfsupply.com

GFK-2441
New In Stock!
~~GE Fanuc Manuals~~

<http://www.pdfsupply.com/automation/ge-fanuc-manuals/rx3i-plc/GFK-2441>

rx3i-plc
1-919-535-3180

PACSystems RX3i High-Speed Counter Modules Manual,

www.pdfsupply.com

Email: sales@pdfsupply.com

GE Fanuc Automation
Programmable Control Products

PACSystems® RX3i

High-speed Counter Modules

User's Manual, GFK-2441

November 2006



Warnings, Cautions, and Notes as Used in this Publication

Warning

Warning notices are used in this publication to emphasize that hazardous voltages, currents, temperatures, or other conditions that could cause personal injury exist in this equipment or may be associated with its use.

In situations where inattention could cause either personal injury or damage to equipment, a Warning notice is used.

Caution

Caution notices are used where equipment might be damaged if care is not taken.

Note

Notes merely call attention to information that is especially significant to understanding and operating the equipment.

This document is based on information available at the time of its publication. While efforts have been made to be accurate, the information contained herein does not purport to cover all details or variations in hardware or software, nor to provide for every possible contingency in connection with installation, operation, or maintenance. Features may be described herein which are not present in all hardware and software systems. GE Fanuc Automation assumes no obligation of notice to holders of this document with respect to changes subsequently made.

GE Fanuc Automation makes no representation or warranty, expressed, implied, or statutory with respect to, and assumes no responsibility for the accuracy, completeness, sufficiency, or usefulness of the information contained herein. No warranties of merchantability or fitness for purpose shall apply.

The following are trademarks of GE Fanuc Automation, Inc.

Alarm Master	Genius	ProLoop	Series Six
CIMPLICITY	Helpmate	PROMACRO	Series Three
CIMPLICITY 90-ADS	Logicmaster	PowerMotion	VersaMax
CIMSTAR	Modelmaster	PowerTRAC	VersaPoint
Field Control	Motion Mate	Series 90	VersaPro
GEnet	PACSystems	Series Five	VuMaster
	Proficy	Series One	Workmaster

Chapter 1	Introduction	1-1
	Introduction to PACSystems RX3i High-speed Counter Modules	1-2
	Module Specifications.....	1-3
	Introduction to Counter Operation.....	1-4
	Introduction to Counter Types.....	1-5
	Introduction to High-Speed Counter Module Configuration	1-6
	Configurable Module Features	1-6
	Configurable Counter Features	1-7
	Configurable Counter Sources	1-8
	Introduction to Data Handling.....	1-9
	Contents of the Input Data	1-9
	Contents of the Output Data.....	1-10
	Introduction to Using Interrupts	1-11
	Introduction to High-Speed Counter Applications	1-12
Chapter 2	Installation and Wiring	2-1
	Field Wiring: IC695HSC304	2-2
	Field Wiring: IC965HSC308	2-3
	Output Points versus Temperature	2-4
	Module LEDs.....	2-5
	Wiring for External Devices.....	2-6
	Transducer Connections	2-6
	Encoder Connections	2-6
	Wiring for TTL Open-Collector Input Devices.....	2-8
Chapter 3	Counter Operation	3-1
	Internal Elements of a High-Speed Counter	3-2
	The Counter Accumulator	3-3
	Starting Value in the Accumulator	3-3
	Count Limits.....	3-4
	Counter Disable.....	3-4
	Count Mode	3-5
	Clock Input Sources	3-6
	Counter Clock Type.....	3-7
	A Quad B Mode	3-10
	Counting with Four Clock Inputs	3-11
	Counts per Timebase Register	3-12
	Rate of Change Monitoring	3-12
	Counter Preloads	3-13
	Counter Strobe Registers.....	3-15
	Strobe Triggers.....	3-15
	Strobe Status Bit.....	3-16

	Strobe Disable Input	3-16
	Sequenced Strobing	3-17
	Counter Setpoints	3-18
Chapter 4	Counter Types.....	4-1
	Type A Counter	4-2
	Type B Counter	4-3
	Type C Counter	4-4
	Homing Operation of a Type C Counter.....	4-5
	Type D Counter	4-6
	Homing Operation of a Type D Counter.....	4-7
	Type E Counter	4-8
	Operation of the Type E Counter	4-9
	Type Z Counter	4-12
	Operation of the Clock Z Input	4-13
	User-Defined Counter	4-14
	The Clear Counter Input.....	4-15
	Preload Disable	4-16
	Homing Options for the User-Defined Counter	4-16
	Strobing Options for the User-Defined Counter	4-16
	Count Down to Zero Pulse Mode for the User-Defined Counter.....	4-18
Chapter 5	Configuration	5-1
	Configuration Basics	5-2
	High-Speed Counter Module Settings	5-3
	I/O and Diagnostic Settings	5-4
	General Settings.....	5-5
	Configuring the Module's Inputs	5-6
	Configuring the Module's Outputs.....	5-7
	Configuring the Counters	5-9
	Counter General Settings	5-9
	Setpoint Limits	5-12
	Setpoint Outputs.....	5-13
	Preload Settings	5-13
	Range and Limit Settings	5-14
	Event Reporting Settings.....	5-17
	Configuring the Counter Sources.....	5-18
	Counter Source Definitions	5-19
Chapter 6	Module Data	6-1
	Module Data Types and References	6-2
	Input Data.....	6-3
	Input Data Updates.....	6-3
	Counter Input Register Data.....	6-4

	Counter Status Data	6-5
	I/O Status Data	6-7
	Module Status Data	6-8
	Output Data	6-10
	Overview of Sending Output Data	6-10
	Module Control Data.....	6-11
	Output Control Data.....	6-14
	Counter Control Data.....	6-15
	Using DO I/O and Suspend I/O	6-17
	Using DO I/O with I/O Interrupts.....	6-17
	DO I/O Function Block Format	6-18
Chapter 7	Using Interrupts	7-1
	Interrupt Handling.....	7-2
	Setting I/O Interrupt Priority.....	7-3
	Types of Interrupts	7-4
	Input Transition Interrupts	7-4
	Output Circuit Fault Interrupts	7-4
	Counter Status Interrupts	7-4
	The Interrupt Logic	7-6
	Masking I/O Interrupts.....	7-7
	Masking and Unmasking Interrupts with SVCREQ 17	7-7
	Suspending and Resume I/O Interrupts Using SVC_REQ 32	7-9
Chapter 8	Application Examples.....	8-1
	Monitoring and Controlling Differential Speeds.....	8-2
	Direction-Dependent Positioning.....	8-3
	RPM Indicator.....	8-5
	Tolerance-Checking	8-6
	Pulse Width Timer.....	8-7
	Pulse Width Timing Using Counter Disable	8-7
	Pulse Width Timing Using Sequenced Strobing	8-7
	Generating a PWM Output Using the Setpoint Registers	8-8
	Measuring Pulse Time	8-9
	Measuring Total Material Length	8-10
	Material Handling Conveyor Control	8-11
	Timing Pulse Generation.....	8-12
	Dynamic Counter Preloading	8-13
	Carousel Tracking	8-14

Contents

Chapter *Introduction*

1

This chapter is an introduction to the PACSystems RX3i High-speed Counter modules. It includes:

- Introduction to PACSystems RX3i High-Speed Counter Modules
- Introduction to Counter Operation
- Introduction to Counter Types
- Introduction to High-Speed Module Configuration
 - Configurable Module Features
 - Configurable Counter Features
 - Configurable Counter Sources
- Introduction to High-Speed Counter Module Data Handling
 - Contents of the Input Data
 - Contents of the Output Data
- Introduction to Using Interrupts
- Introduction to High-Speed Counter Applications

Additional Documentation

PACSystems High-speed Counter Modules IC695HSC304 and IC695HSC308, GFK-2450.

This datasheet-type document contains the most up-to-date release information for these two modules. It also includes the same module descriptions, specifications and wiring information that are found in this user manual.

PACSystems RX3i System Manual, GFK-2314. This manual details installation procedures, and includes descriptions and specifications of PACSystems RX3i I/O and option modules.

PACSystems RX3i user manuals, module datasheets, and other important product documents are available online at www.gefanuc.com. They are also included in the *Infolink for PLC* documentation library on CDs, catalog number IC690CDR002.

RX3i High-speed Counter modules function as part of a larger control system. Additional documentation may be needed to complete the system installation and configuration.

Introduction to PACSystems RX3i High-speed Counter Modules

PACSystems RX3i High Speed Counter modules provide direct processing of rapid pulse signals up to 1.5 MHz for industrial control applications such as:

- Turbine flowmeter
- Meter proving
- Velocity measurement
- Material handling
- Motion control
- Process control

These modules can sense inputs, process input count information, and control outputs without communicating with the CPU.

High-speed Counter module IC695HSC304 provides: 8 high-speed inputs, 7 high-speed outputs, and 1 to 4 counters.

High-speed Counter module IC695HSC308 provides: 16 high-speed inputs, 14 high-speed outputs, and 1 to 8 counters.

Standard counter types A, B, C, D, E, Z, and a user-defined type can be combined on a module.

Module features include:

- Terminal Block insertion or removal detection
- Meets CE, UL/CUL 508 and 1604, and ATEX requirements
- Flash memory for future upgrades
- Module fault reporting
- Configurable I/O Interrupts
- Select parameters easily changed without re-configuration.

This module must be located in an RX3i Universal Backplane. An RX3i CPU with firmware version 3.81 or later is required. Machine Edition 5.50 with Service Pack 2 SIM 3 or later is required for configuration.

This module can be used with a Box-style (IC694TBB032), Extended Box-style (IC694TBB132), Spring-style (IC694TBS032), or Extended Spring-style (IC694TBS132) Terminal Block. Extended terminal blocks provide the extra shroud depth needed for shielded wiring. See the *PACSystems RX3i System Manual*, GFK-2314 revision B or later for more information about Terminal Blocks. Terminal Blocks are ordered separately.

RX3i High-speed Counter Modules can be hot-inserted and removed following the instructions in the *PACSystems RX3i System Manual*, GFK-2314. When the module is removed from the backplane or power-cycled, it stops counting and accumulated counts are lost.

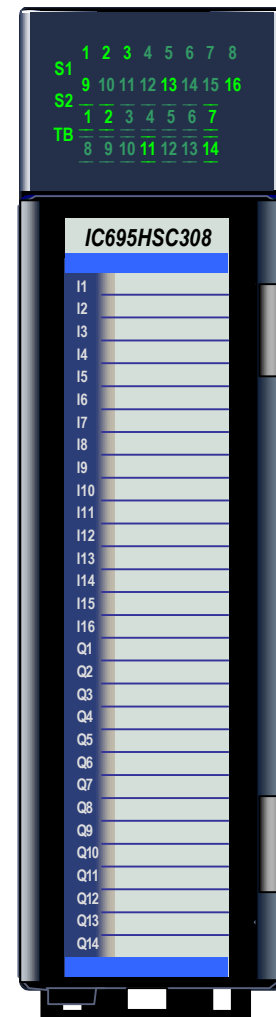

Module Specifications

Number of Counter Channels	IC695HSC304: 4 counters (8 inputs and 7 outputs) IC695HSC308: 8 counters (16 inputs and 14 outputs)	
High Speed Counter Types	Configurable as Type A, Type B, Type C, Type D, Type E, Type Z, and User-Defined.	
Maximum Count Rates	1.5MHz with configurable input filtering, all counter types except 750kHz for Type C or User-Defined when using four counter inputs. (40MHz internal oversampling). For A-Quad B count mode, 1.5MHz is the overall count rate.	
Counting Range	-2147483648 to +2147483647	
Backplane Power Requirements	IC695HSC304:	64mA maximum @ 5V 457 mA maximum @ 3.3V
	IC695HSC308	94mA maximum @ 5V 561 mA maximum @ 3.3V
LEDs	Module Status (S1), Field Status (S2), Terminal Block (TB), plus LEDs to indicate state of each input and output point.	
Input Voltages	5VDC nominal: 4.7VDC to 5.5VDC 12 to 24VDC nominal: 10VDC to 26.4VDC	
Peak input voltage	35VDC	
Input Impedance	>5k Ohms	
Number of Outputs	IC695HSC304 - 7 outputs IC695HSC308 - 14 outputs	
Output Voltage Range	4.7 to 40VDC	
Output Current Rating	1.5A maximum per channel, 10.5A maximum per module	
Thermal Derating	Number of output points on at the same time depends on ambient temperature and current per point. For module IC695HSC308, thermal derating also depends on distribution of output points on the module. See chapter 2 for details.	
Output Control	Module outputs can be mapped to any number of counter setpoint outputs. Each counter controls up to 4 setpoints with "turn on" and "turn off" values. If multiple setpoint outputs are assigned to the same external module output, the signals are logically ORed. External outputs can optionally be configured for control through output scan bits from PLC memory.	
Surge Current per Point	4.5A < 450uS (Self-protected for overcurrent faults)	
Minimum Load Current	0mA (up to 150mA to satisfy open load detection)	
Maximum On State Voltage Drop/Output	0.35V @ 1.5A	
Maximum Off-State Leakage Current/Output	200uA	
Output Delay time	Off to On: 125uS @ 1.5A On to Off: 85uS @ 1.5A	
Current Limit	4.5A < 450uS, 1.5A continuous	
Reverse Polarity Protection	Outputs protected from reverse wiring	
Isolation:	<i>Field to Backplane:</i> 250 VAC continuous; 1500 VAC for 1 minute <i>Field to Frame Ground, Inputs to Outputs, Output Group A to Output Group B:</i> 50 VAC continuous; 500 VAC for 1 minute	

Refer to the *PACSystems RX3i System Manual*, GFK-2314, for product standards and general specifications.

Introduction to Counter Operation

High-Speed Counter module IC695HSC304 provides four internal counters with the internal elements shown below. Module IC695HSC308 provides eight of these internal counters.

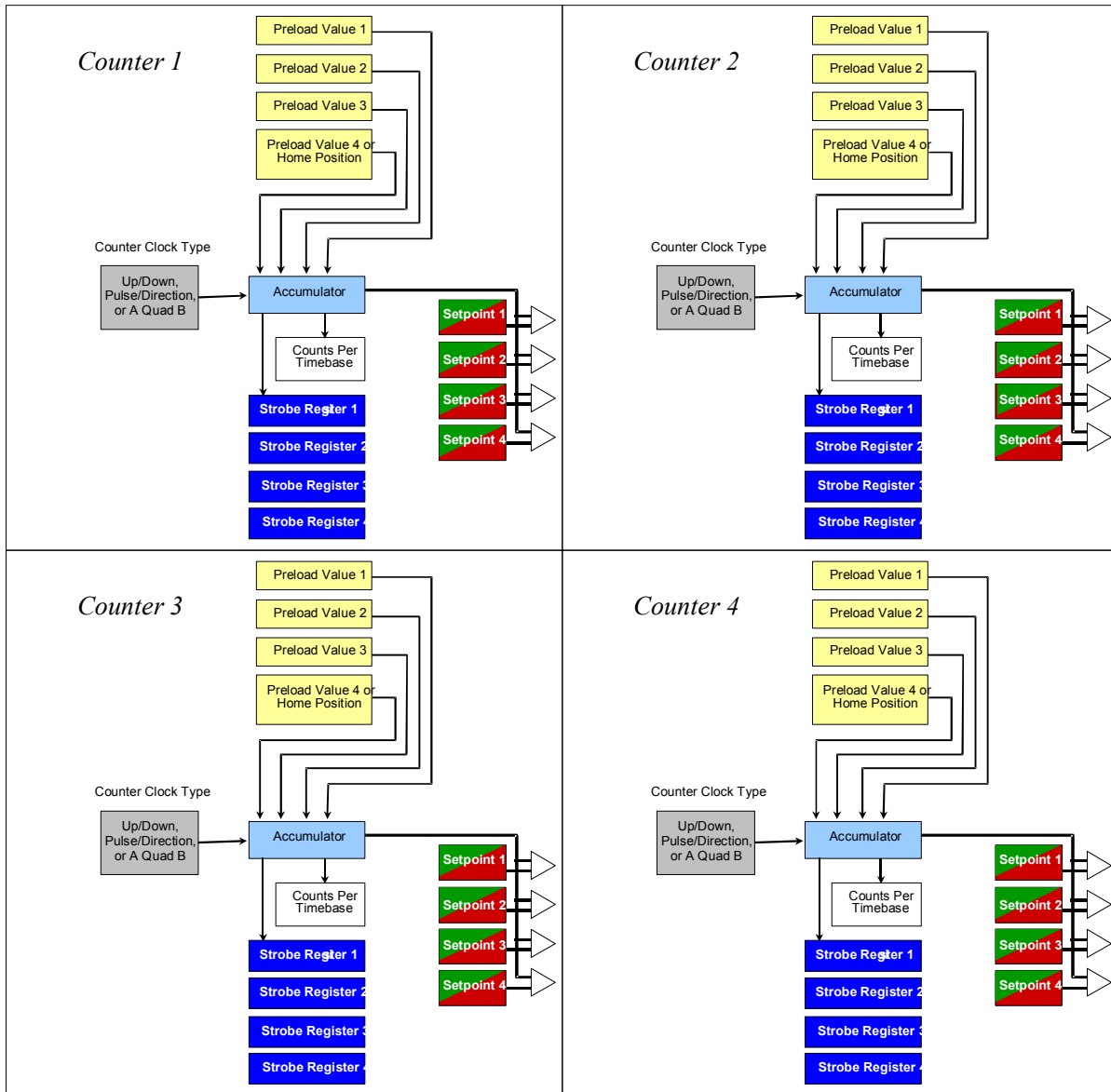

Each internal counter has one to four Clock Inputs, a 32-bit Accumulator register, up to four Preload registers, up to four Strobe registers, a Counts-per-Timebase register, and four Setpoint Outputs. Each counter can be configured for Continuous or One-Shot Count Mode, and assigned range limits. In addition, each counter can be configured for Up/Down, Pulse/Direction, or A Quad B counting. Counters with four Clock Inputs perform differential counting. See chapter 3 for details of these basic counter features.

Introduction to Counter Types

The internal counters of PACSystems RX3i High-speed Counter modules can be set up as several different Counter Types, which are referred to as: Type A, Type B, Type C, Type D, Type E, and Type Z. An additional User-Defined type can be customized as needed for the application. The operation of Counter Types A, B, C, D, and E differs in some respects from similarly-named High-Speed Counters for other GE Fanuc PLC products. Users who are familiar with those counter types should read the counter descriptions in this book for more information. Counter Types are summarized below and described in detail in chapter 4.

Module IC695HSC304 has four internal counters. Module IC695HSC308 has eight. These internal counters can operate as multiple Counter Types. Most configurable Counter Types use one internal counter. The Type E Counter uses two.

Counter Type	Sources
<i>Type A Counter</i>	A simple counter that can count either up or down. A Type A Counter has one Clock input, a Preload input, and a Strobe input.
<i>Type B Counter</i>	A more complex type of counter, Type B has a pair of Clock inputs, two Strobe inputs, and a Preload input. It also has a Disable input that can be used to suspend counting.
<i>Type C Counter</i>	More complex than Type B, Type C is suitable for applications requiring motion control, differential counting, or homing capability. A Type C Counter uses two pairs of Clock inputs. The first pair increments the Accumulator and the second pair decrements the Accumulator. Type C also has three Strobe inputs, two Preload inputs, and a Home Marker and Home Switch input.
<i>Type D Counter</i>	Type D is a less complex counter that also provides homing capability. It has one pair of Count inputs and a Home Marker input.
<i>Type E Counter</i>	Type E is the only pre-defined Counter Type that occupies two of the module's internal counters. Type E is primarily a down counter, but it can handle up counts to account for A quad B jitter. When a Type E counter counts down to zero, it uses a second counter block to turn on a dedicated output for a configurable time. Type E can be set up for sequenced strobing, which links all four strobes on so that they are all triggered by strobe input 1.
<i>Type Z Counter</i>	Type Z has two regular Clock inputs, a Preload input and a special Clock Input Z. The Z input triggers a store of the Accumulator value to the Strobe 1 register. After the store, the counter can optionally reset the Accumulator to 0. It can then either restart immediately or after wait until the Clock Input Z is no longer set.
<i>User-Defined Counter Type</i>	The User-Defined Counter makes it possible to create a customized counter type by selecting High-Speed Counter features that are suited to the application. This counter type provides a Clear input that can be used to immediately reset the Accumulator to the starting value.

Introduction to High-Speed Counter Module Configuration

Chapter 5 describes the configurable parameters of PACSystems RX3i High-speed Counter modules.

Configurable Module Features

Basic configuration of a High-Speed Counter module includes assigning CPU references for the module's data.

<i>Data Type</i>	<i>IC695HSC304 Data Length</i>	<i>IC695HSC308 Data Length</i>
<i>Counter Status Data</i>	128 bits	256 bits
<i>Counter Register Data</i>	56 words	112 words
<i>Counter Control Data</i>	128 bits	256 bits
<i>Module Control Data</i>	28 words	
<i>I/O Status Data</i>	64 bits	
<i>Output Control Data</i>	32 bits	
<i>Module Status Data</i>	32 bits	

Basic configuration also includes setting up the operating characteristics of the module and of its external input and output points.

<i>Module Settings</i>	Fault reporting if the module's terminal block is removed
	Threshold voltage for all external inputs: 5 volts or 12/24 volts
	All external inputs either default to off or Hold Last State if module's terminal block is removed
	I/O Scan Set
<i>Per-Input Settings</i>	Input filter: 30Hz, 50KHz, 500KHz, or 5MHz
	Input transition generates Interrupt
	If Input transition interrupt is enabled, its edge sensitivity
<i>Per-Output Settings</i>	Circuit fault reporting
	Circuit fault generates interrupt
	Output's on/off state controlled by either program logic or counter setpoints
	Output defaults to Off, On, Last State, or continues operating if CPU is stopped or in Run-Disabled mode.

Configurable Counter Features

The first step in counter configuration is to select a Counter Type: A, B, C, D, E, Z, or User-Defined. Counter Types are explained in chapter 4. Each Counter Type can then be configured for a unique set of features as indicated below. In addition to their configurable [■] features, some Counter Types have fixed features as shown in the table.

Counter Type	Type A	Type B	Type C	Type D	Type E	Type Z	User-Defined
Number of Clock Inputs	1	2	4	2	2	2	■
Fixed Count Direction	■						
Counter Clock Type		■	■	■	■	■	■
Second Counter Clock Type			■				■
Timebase	■	■	■	■	■	■	■
Timebase Units	■	■	■	■	■	■	■
Pre-scale (Divider)	■	■	■	■	■	■	■
Count Down to Zero Pulse					yes		■
Strobe Overwrite	■	■	■	■	■	■	■
Sequenced Strobing					■		■
Homing Feature			yes	yes			■
Setpoint 1 ON Limit	■	■	■	■	■	■	■
Setpoint 1 OFF Limit	■	■	■	■	■	■	■
Setpoint 2 ON Limit	■	■	■	■	■	■	■
Setpoint 2 OFF Limit	■	■	■	■	■	■	■
Setpoint 3 ON Limit	■	■	■	■	■	■	■
Setpoint 3 OFF Limit	■	■	■	■	■	■	■
Setpoint 4 ON Limit	■	■	■	■	0	■	■
Setpoint 4 OFF Limit	■	■	■	■	0	■	■
Setpoints [Outputs] 1 to 4	■	■	■	■	■	■	■
Preload 1 Value	■	■	■		■	■	■
Preload 2 Value			■		■		■
Preload 3 Value							■
Preload 4 Value							■
Home Position Value			■	■			■
Count Mode	■	■	■	■	■	■	■
Under Range Limit and Over Range Limit	■	■	■	■	■	■	■
Rate of Change	■	■	■	■	■	■	■
Response Output Mode					■		
Outpulse Milliseconds					■		
Response Output Point					■		
Fault Enable	■	■	■	■	■	■	■
Interrupt Enable	■	■	■	■	■	■	■

Configurable Counter Sources

Counter sources generally include the module’s inputs and outputs, a control data reference, the module’s internal oscillator, the count of another counter, setpoints, or out-of-range conditions. Sources can be individually configured to respond to high/rising or low/falling edges and/or levels. The number and type of sources that can be configured depend on the Counter Type that has been selected.

Counter Type	Type A	Type B	Type C	Type D	Type E	Type Z	User-Defined
Clock Input 1 Source	■	■	■	■	■	■	■
Clock Input 2 Source		■	■	■	■	■	■
Clock Input 3 Source			■				■
Clock Input 4 Source			■				■
Clock Input Z Source						■	
Counter Disable Source		■	■		■		■
Strobe 1 Source	■	■	■		■		■
Strobe 2 Source			■				■
Strobe 3 Source			■				■
Strobe 4 Source							■
Preload 1 Source	■	■	■		■		■
Preload 2 Source			■		See below		■
Preload 3 Source							■
Preload 4 Source							■
Clear Source							■
Home Switch Source			On				■
Home Marker Source			■	■			■
Preload Disable Source							■
Strobe Disable Source					■		■

A Type E counter will roll over to the Preload 2 value if the Count Mode configuration parameter is set to Continuous. The Source of Preload 2 is fixed at Setpoint 4 when Count Mode is Continuous. It is fixed at None when Count Mode is set to Single Shot. The Preload 2 value is also the starting Accumulator value for a Type E counter, but it cannot be triggered from the application logic because its trigger source is fixed at None.

Introduction to Data Handling

Chapter 6 describes all of the input and output data used by a PACSystems RX3i High-speed Counter module. It also explains the sequence in which data is exchanged, and describes how the DO I/O function can be used to read or write module data on command from the application program. Suspend I/O program functions can also be used to suspend normal I/O updates for the module.

Contents of the Input Data

Each CPU scan, the module's input data automatically provides the CPU with information about the module and its counters. Depending on the configuration, some of this data may not be used.

<i>Counter Register Data</i>	<ul style="list-style-type: none"> the Accumulator (count) value the Strobe value(s) the Counts per Timebase value
<i>Counter Status Data</i>	<ul style="list-style-type: none"> the strobe(s) current states the preload(s) current states the setpoint outputs(s) current states Home cycle completion status Setpoint interrupt(s) status Rate of Change Limit exceeded status Accumulator Overrange or Underrange status Accumulator Overflow or Underflow status Encoder fault status
<i>I/O Status Data</i>	<ul style="list-style-type: none"> External inputs and external outputs states External inputs interrupt states External output states External outputs fault status
<i>Module Status Data</i>	<ul style="list-style-type: none"> Module ready status Terminal Block status Field Power status Command error status If an error has occurred, an error description

Contents of the Output Data

The CPU can easily send commands to the module using its output data. The configured Counter Type determines which commands can be used.

<i>Counter Control Data</i>	<ul style="list-style-type: none"> Trigger a Strobe or Preload Acknowledge a Strobe or Preload Clear the counter Accumulator to 0 Enable or disable Preloads, counting, or Strobing Set the counter direction up or down Execute Homing
<i>Module Control Data</i>	<ul style="list-style-type: none"> Enable or disable outputs Acknowledge / clear errors Load a value into the counter Accumulator Set Underrange and Overrange limits Set the timebase for the Counts per Timebase register Set On and Off values for Setpoint Outputs Enable or disable individual Setpoint interrupts Enter a Preload value for the Accumulator Load a one-shot adjustment into the Accumulator Load an input filter frequency
<i>Output Control Data</i>	<ul style="list-style-type: none"> Turn the external output points on or off

Introduction to Using Interrupts

An IC695HSC304 module can provide up to six I/O Interrupts; an IC695HSC308 module can provide up to ten I/O Interrupts.

There are three basic types of Interrupts:

- Transition Interrupts for the module's external inputs. Optional input transition interrupt conditions include: Rising Edge, Falling Edge, or Both Edges options for each external input.
- Circuit Fault Interrupts for the module's external outputs can be configured to trigger an I/O Interrupt if a circuit fault (short-circuit or open-circuit) occurs.
- For each counter, Counter Status Interrupts can be individually configured for: Overrange, Underrange, Encoder Fault, Overflow, Underflow, Rate of Change, and Setpoint On/Off Conditions.

If an interrupt condition occurs, the High-speed Counter module sends its latest Counter Status and Counter Register data to the CPU. The CPU suspends its current activity, updates the Counter Status and Counter Register data, then executes an associated block of interrupt logic. If the Interrupt is a Counter Interrupt, the Counter Status and Counter Register data is updated for that counter only (not all counters).

Individual interrupts can be masked and subsequently unmasked from the CPU via the module's assigned memory references. In addition, the application program can use Service Request commands to mask and unmask interrupts, and to suspend or resume interrupts.

Please refer to chapter 7 for details of using Interrupts. Information about configuring I/O Interrupts is provided in chapter 5.

Introduction to High-Speed Counter Applications

Check chapter 8 for some examples of basic High-Speed Counter functionality.

- Monitoring and controlling differential speeds using the differential counting capability of a Type C or User-Defined Counter. In this application, the counter Accumulator automatically tracks the speeds of two machines, and the differences between them.
- Direction-dependent positioning using two Type B counters operating in A Quad B mode. This application uses Setpoint Outputs to control external devices as a crane travels along a track.
- RPM indicator using a Type A, B, C, D, or User-Defined Counter connected to an encoder.
- Tolerance-checking using a Type B counter to measure the length of parts on a conveyor.
- Pulse-Width Timer using a Type B, C, E, or User-Defined Counter with the pulse used as a source for the Counter Disable input.
- Measuring Pulse Width using the Sequenced Strobing feature of a Type E or User-Defined Counter.
- Generating a PWM output using a counter's four Setpoint Outputs, configured so that as each output goes off, the next one goes on.
- Measuring Pulse Time using a Type B counter with the module's internal 2MHz oscillator serving as the Count 1 source and two Strobe Inputs to capture the count value.
- Measuring total material length using a Type B counter with an encoder connected to the Count 1 input and a sensor as the source of the Disable input.
- Material handling conveyor control using an encoder and a Type B Counter.
- Digital velocity control using a Type B counter providing a velocity value to an analog output module.
- Counter preloading using the Home feature of a Type C or User-Defined Counter.
- Carousel tracking using a Type C or User-Defined Counter to track the position of items in the carousel and retrieve them as the carousel rotates.

Chapter Installation and Wiring

2

This chapter describes:

- Field Wiring for High-speed Counter Module IC695HSC304
- Field Wiring for High-speed Counter Module IC695HSC308
- Output Points versus Temperature
- Module LEDs
- External Devices
 - Transducer Connections
 - Encoder Connections
 - Wiring for TTL-Open Collector Input Devices

Field Wiring: IC695HSC304

Field wiring connections to the module are made to the removable terminal assembly, as described in the *RX3i System Manual*, GFK-2314. For this module, each row of terminals (eg: 1-18, 19-36) is internally connected. The dual connection points are for wiring convenience; the module cannot be wired for differential inputs.

Connections	Terminals	Terminals	Connections
Input 1	1	19	Input 1
Input 2	2	20	Input 2
Input 3	3	21	Input 3
Input 4	4	22	Input 4
Input 5	5	23	Input 5
Input 6	6	24	Input 6
Input 7	7	25	Input 7
Input 8	8	26	Input 8
Common	9	27	Common
Output 1	10	28	Output 1
Output 2	11	29	Output 2
Output 3	12	30	Output 3
Output 4	13	31	Output 4
Output 5	14	32	Output 5
Output 6	15	33	Output 6
Output 7	16	34	Output 7
DC+ for Voltage Source A	17	35	DC+ for Voltage Source A
DC- for Voltage Source A	18	36	DC- for Voltage Source A

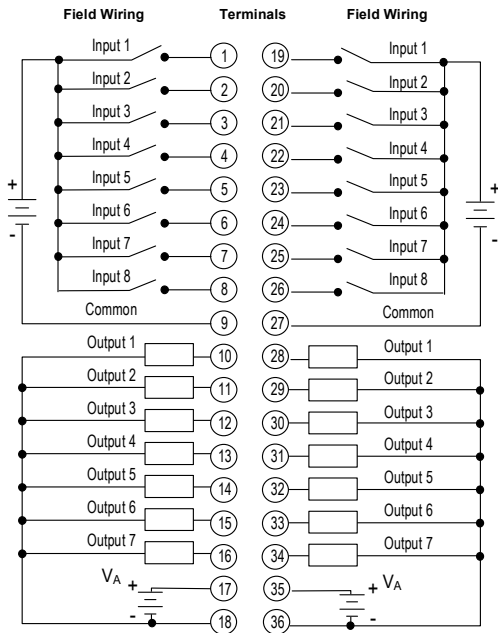

Field Wiring: IC965HSC308

Field wiring connections to the module are made to the removable terminal assembly, as described in the *RX3i System Manual*, GFK-2314. All 16 High-Speed Counter inputs on this module are positive logic (source) type.

Connections	Terminals	Terminals	Connections
Input 1	1	19	Input 9
Input 2	2	20	Input 10
Input 3	3	21	Input 11
Input 4	4	22	Input 12
Input 5	5	23	Input 13
Input 6	6	24	Input 14
Input 7	7	25	Input 15
Input 8	8	26	Input 16
Common	9	27	Common
Output 1	10	28	Output 8
Output 2	11	29	Output 9
Output 3	12	30	Output 10
Output 4	13	31	Output 11
Output 5	14	32	Output 12
Output 6	15	33	Output 13
Output 7	16	34	Output 14
DC+ for Voltage Source A	17	35	DC+ for Voltage Source B
DC- for Voltage Source A	18	36	DC- for Voltage Source B

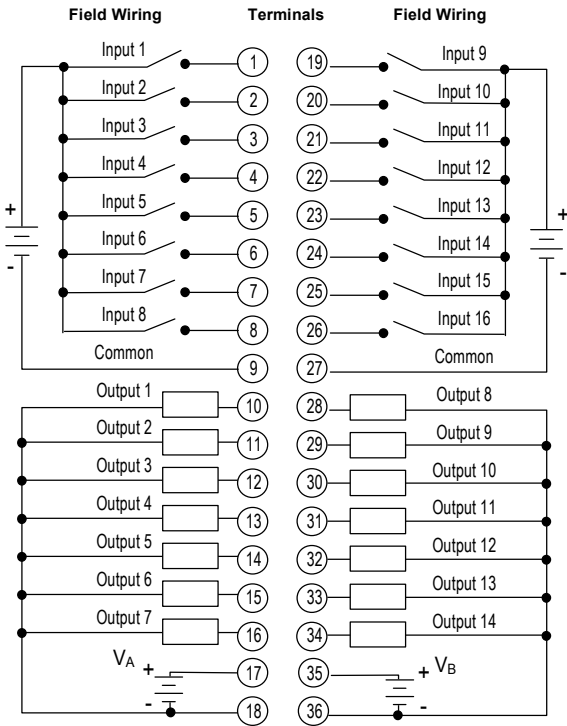

Inputs 1 to 8 and 9 to 16 form two isolated input groups, each with its own common terminal. Outputs 1 to 7 and 8 to 14 form two isolated output groups, each with its own voltage connections. Outputs should be evenly distributed between the two output groups, as discussed under "Output Points versus Temperature".

Output Points versus Temperature

The charts below show thermal deratings for modules IC695HSC304 and IC695HSC308 with maximum loads of 0.75A on each output.

For example, if five outputs are used on module IC695HSC304, at 60C the total current of all outputs would be 3.75 Amps. If smaller loads are used on the outputs, then more output channels can be used at a given temperature.

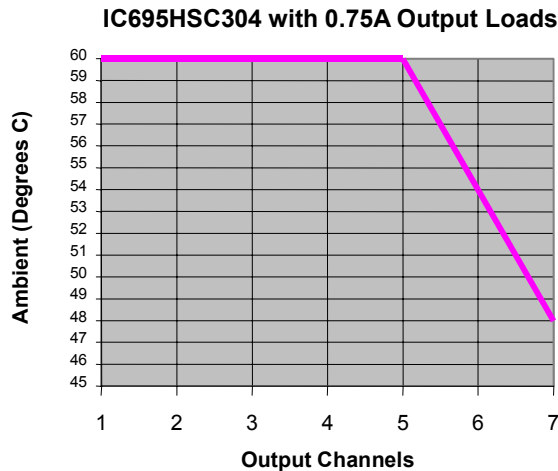

For module IC695HSC308, more output channels can be used at the same time at a given ambient temperature when outputs are evenly distributed into two groups. If outputs are either set up as one output group or unevenly distributed between two output groups, fewer output channels can be used for a given ambient temperature.

For example, if eight outputs are used on module IC695HSC308, and they are equally distributed between two output groups, the total current of all outputs at 60C can be up to 6 Amps. At a given ambient temperature, if smaller loads are used on the outputs, more output channels can be used.

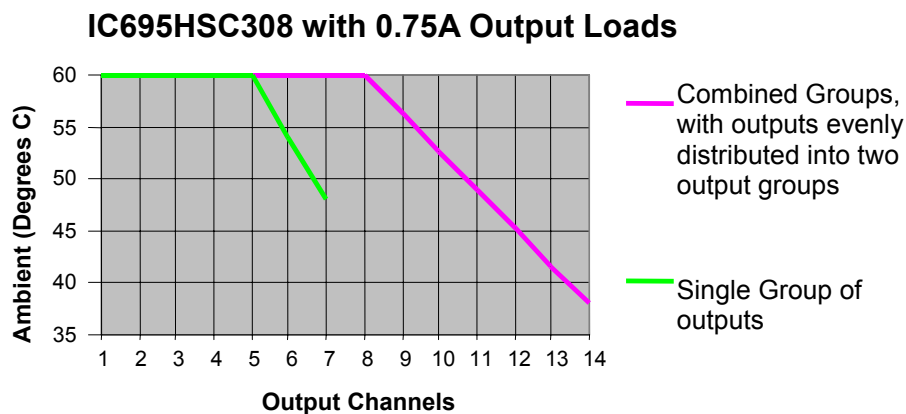

Module LEDs

Individual green LEDs indicate the ON/OFF status of the module's external input and output points. These LEDs are green when the corresponding points are on. They are off when the corresponding points are off.

Output LEDs show the commanded output states, including any output disable conditions, %Q bit states, and STOP mode defaults. When the PLC is in Run mode, the LEDs indicate the states of the outputs regardless of whether or not field power is present. If the PLC is not in Run mode, the LEDs indicate the default states of the outputs.

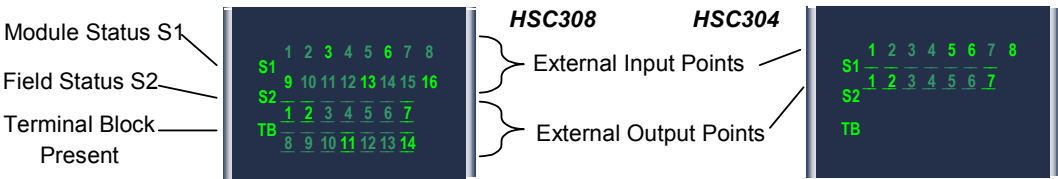

The Module Status (S1) LED indicates the status of the module. Solid green indicates that the module has been configured. Blinking green indicates no configuration. Blinking amber/yellow indicates a fatal module failure.

The Field Status (S2) LED is off if field power is not present. For module IC695HSC308, this LED is off unless power is present on BOTH V_A and V_B. Solid green indicates that field power is present and that no output circuit faults have been detected on circuits for which fault detection has been enabled in the configuration. If S2 is amber/yellow, field power is present but circuit faults exist for one or more outputs.

The module's red/green Terminal Block LED is green when the module's removable terminal block is locked in place. It is red when the terminal block is not locked. The module also sends an *Addition of Terminal Block* or *Loss of Terminal Block* message to the RX3i CPU to report the Terminal Block status.

During a firmware update, the S1, S2, and TB LEDs blink in a green/off pattern.

Wiring for External Devices

Transducer Connections

Transducers with CMOS buffer outputs (74HC04 equivalent) can directly drive the High Speed Counter inputs using the 5V input range.

Transducers using TTL totem pole or open collector outputs must include a 470 ohm pullup resistor (to 5V) to guarantee compatibility with the High Speed Counter inputs.

Transducers using high voltage open collector (sink) type outputs must have a 1K pullup resistor to V+ for compatibility with the High Speed Counter 12/24 volt input range.

Encoder Connections

Z (Marker) Channel: Positive-edge or negative-edge triggered.

Encoder Direction of Travel: Channel A leading Channel B indicates positive direction.

Encoder Power Circuit Diagram

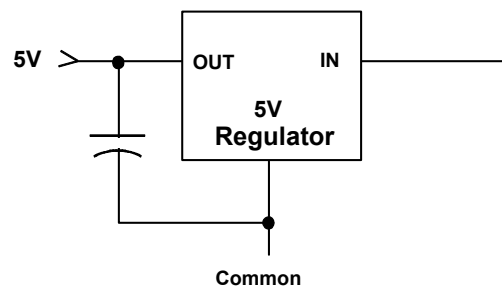

Typical Encoder Connections

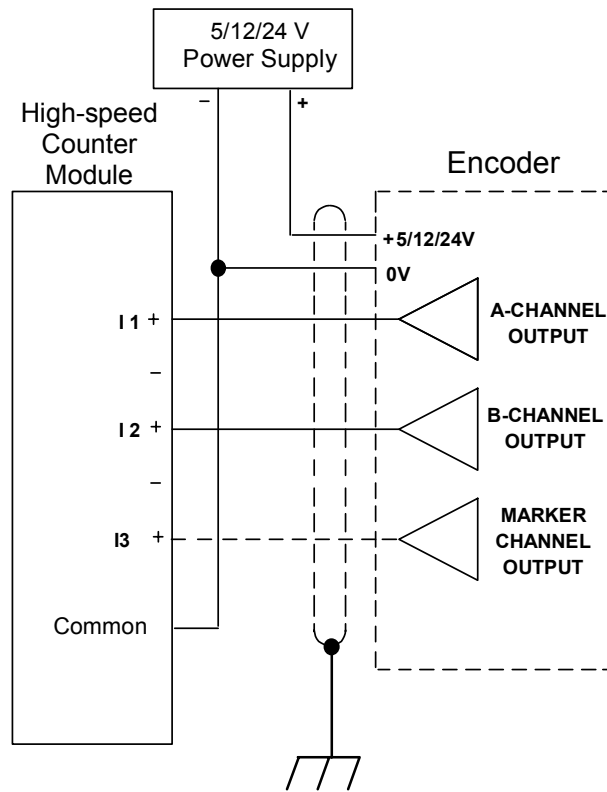

Wiring for TTL Open-Collector Input Devices

For TTL open-collector inputs, an external resistor must be provided. Be sure the input device is capable of handling the load voltage and current represented by the suggested resistor value.

For an external power supply, suggested nominal resistors are:

- 1K ohm, 1/4 Watt, 5% for a +5 volt supply.
- 1.5K ohm, 1/4 Watt, 5% for a +12 volt supply.
- 4.7K ohm, 1/4 Watt, 5% for a +24 volt supply.

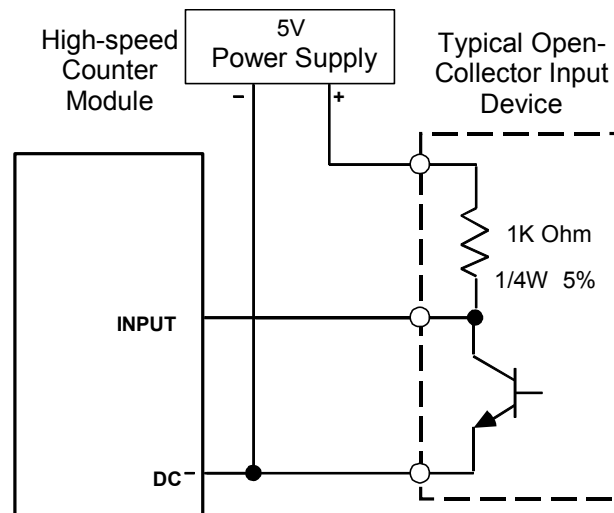

Chapter Counter Operation

3

This chapter describes the operating features of a PACSystems RX3i High-Speed Counter module.

- Internal Elements of a High-Speed Counter
- The Counter Accumulator
- Starting Value in the Accumulator
- Count Limits
- Count Mode
- Counter Clock Type
- Counts per Timebase Register
- Rate of Change Monitoring
- Counter Preloads
- Preload Sources
- Preload Status Bit
- Preload Value
- Preload Disable
- Counter Strobe Registers
- Strobe Triggers
- Strobe Status Bit
- Strobe Register Resets
- Strobe Disable Input
- Sequenced Strobing
- Counter Setpoints
- Operation of a Setpoint Output
- Setpoint On and Off Values
- Separation of Setpoints
- Setpoint Interrupts

Internal Elements of a High-Speed Counter

High-Speed Counter module IC695HSC304 has four internal counters. Module IC695HSC308 has eight internal counters.

Each internal counter includes the following elements:

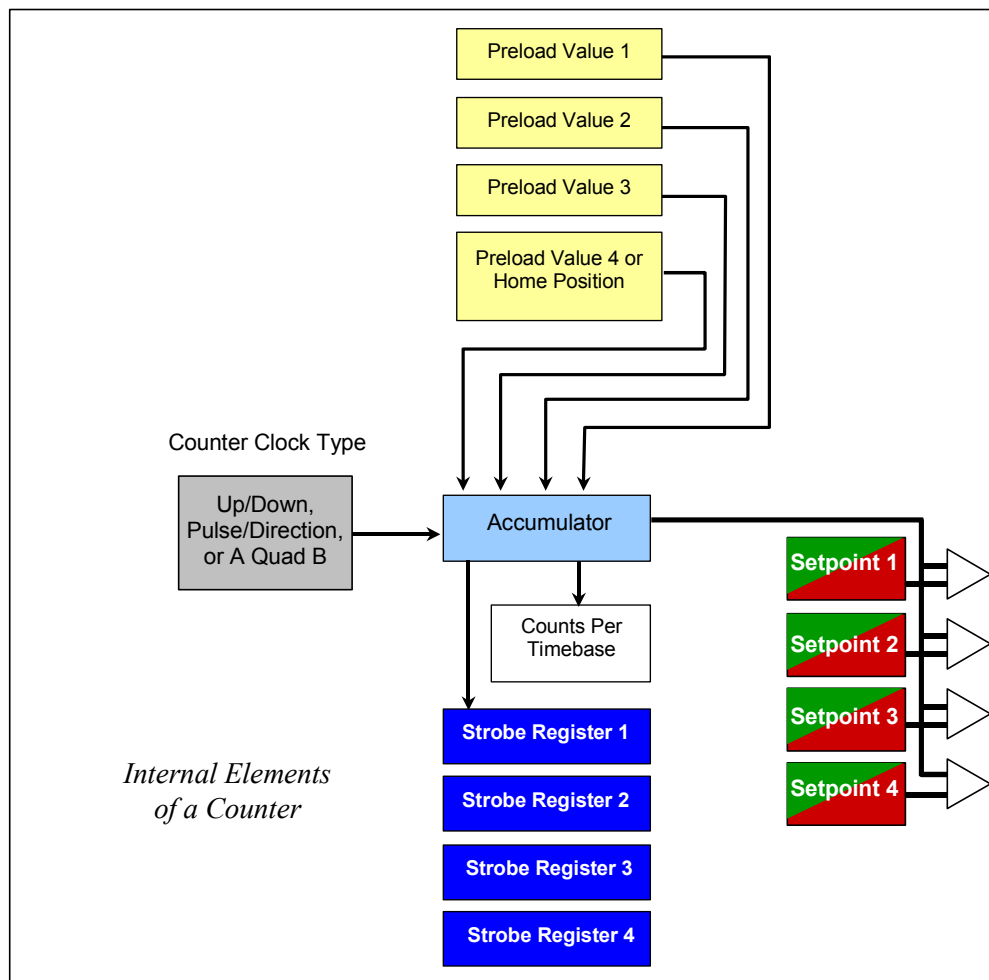

Most pre-defined Counter Types use only some of the internal counter components, as explained in chapter 4.

The data in the internal Accumulator, Counts per Timebase, and Strobe registers is assigned to CPU memory references and automatically provided to the CPU as part of the module's input data. The Preload/Home Position register data is not mapped directly to CPU memory references. However, individual values can be written to these registers as part of the module's output data. Chapter 6 describes the input and output data that is exchanged between the module and the CPU.

The Counter Accumulator

Each counter has one 32-bit Accumulator register that stores the current count value.

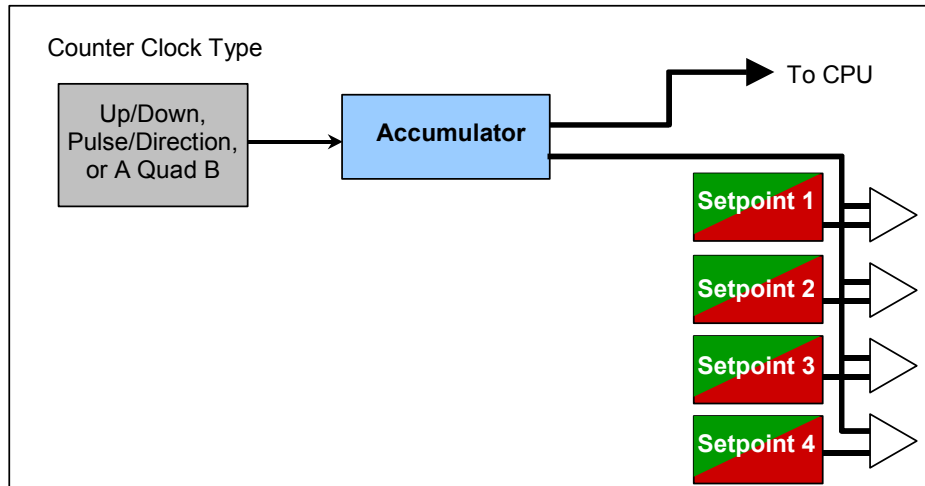

The count value in the Accumulator is automatically provided to the CPU as part of the module's regular input data. It is also normally used to drive the module's external outputs, within configured Setpoint On and Setpoint Off ranges. Each counter can control up to four Setpoint Outputs.

The application program can change the count value in the Accumulator using a Load Accumulator command as part of the module's regular output data. A similar command in the output data can be used to adjust the Accumulator value. See chapter 6 for details.

Starting Value in the Accumulator

Ordinarily, counting starts at zero and goes up or down, depending on the configuration. However, there are several ways to change the starting value of a count.

- By triggering a Preload, which copies the value in a Preload Register into the Accumulator.
- By sending a Load Accumulator command from the CPU.
- By sending a Clear Counter command (User-Defined Counter Type only).

If the counter reaches its maximum it will restart if configured for Continuous counting, or stop if configured for One-Shot counting. Both are explained in this section.

For all counters, if Preload, strobe and clear all occur at the same time, the order of execution is: 1. Strobe, 2. Preload, 3. Clear.

Count Limits

Each Counter Type has a maximum 32-bit count limit of -2147483648 to 2147483647. Within these maximums, each counter can be configured to have a Low Range and High Range limit. These limits are the lower and upper boundaries of the counter's normal operating range, usually used for diagnostics purposes. Both range values can be positive or negative, but the High Range value must always be greater than the Low Range value.

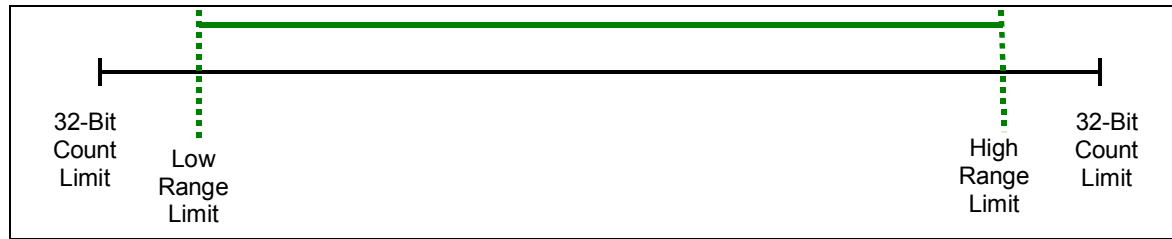

After being initially set in the configuration, Low Range and High Range Limits can be changed during operation using data commands from the CPU. Changes made using data commands do not replace the counter's configured parameters. Commanded changes are not retained through a power cycle, hot swap, PLC clear or reconfiguration.

Attempting to count beyond the High Limit is called Overflow. Attempting to count beyond the Low Limit is called Underflow.

Counter Disable

Type B, Type C, Type E, and User-Defined Counters can be configured to have a Counter Disable input that suspends counting when active. Its polarity is configurable. The Counter Disable input is level-sensitive; counting is inhibited while the Disable input is active.

Counter Disable can alternatively be controlled from the application program, using the Counter Disable Control Data reference (see chapter 6 for details). If the application program should control Counter Disable, the Counter Disable Source for the counter must be configured to use the Control Data Reference.

Count Mode

The configured Count Mode determines what happens when the Accumulator count value reaches its configured upper or lower value.

- In Continuous within Range mode, a counter counts continuously within its configured high and low range limits. If either the high or low limit is reached, the counter wraps around to the other limit and continues counting.
- In One-Shot within Range mode, the counter count to its configured High Range or Low Range value then stops. If the count reaches the High Range or Low Range limit, the direction can be reversed and the counter will back away from the limit.
- In Continuous Beyond Range mode, counting continues beyond the configured High Range or Low Range value, to the Underflow or Overflow limit, then wraps around.
- In One-Shot Beyond High/Low Range mode, the count value may pass the configured High Range/Low Range values. The count must stop at the Overflow/Underflow limit. If the count reaches either limit, a count in the opposite direction will back it away from the limit.

If the counter is configured for either Continuous or One-Shot Counting Beyond Range, the application program can check for beyond range conditions and respond appropriately using the Counter Status input data. Optionally, fault reporting can be enabled on the counter to log a fault to the I/O Fault Table.

The diagram below shows Count Mode operation for all Counter Types except Type E when counting up. Operation when counting down is similar. Operation of the Type E Counter is described in Chapter 4.

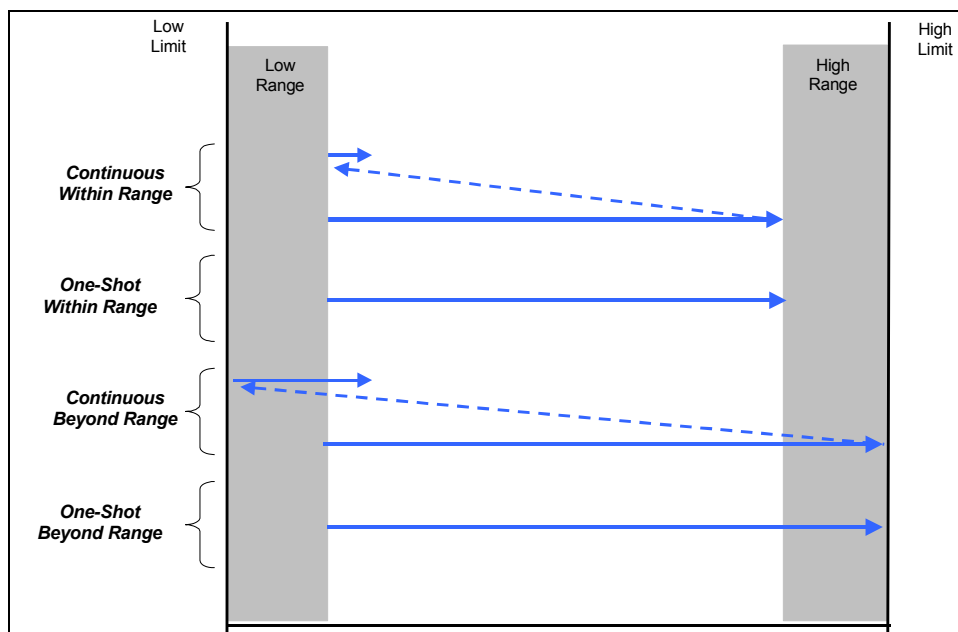

Clock Input Sources

A Type A Counter has one Clock Input. All other Counter Types have either one pair or two pairs of Clock Inputs:

Type A Counter:	1 Clock input
Type B, Type D, Type E, Type Z Counter:	2 Clock inputs
Type C Counter:	4 Clock inputs
User-defined Counter:	2 or 4 Clock inputs

The source of each Clock Input is configurable as described in chapter 5. Clock Input Sources can be:

- Any of the module's external input points.
- Any of the module's external output points.
- The module's internal 2MHz oscillator.
- The count output of one of the other counters on the module.

Input Source: Internal Oscillator

The module's internal 2MHz oscillator can be selected as the Clock Input source for the Up or Down Input on an Up/Down counter, or as the Clock Input on a Clock/Direction counter. Use of the oscillator is easily set up by configuration; no special module wiring is needed. When this source is used, for most applications the count pulse should be scaled down to a slower rate by specifying a Prescale value during configuration.

Input Source: Counter Pulse (Count)

The counter pulse of another counter on the module can be selected as the Clock Input source for the Up or Down Input on an Up/Down counter, or as the Clock Input on a Clock/Direction counter. The Counter Pulse pulses each time the Accumulator in the first counter changes, regardless of whether the Accumulator counts up or counts down. If up and down counts occur on the first counter at the same time, the Accumulator does not change and the Counter Pulse signal does not pulse.

The count pulse rate of the first counter must not be greater than about 1.65MHz (pulses should not be closer together than 0.6 μ s). If the count pulse of the first counter exceeds this rate, some counts may be lost. For example, Counter 1 is configured to be an Up/Down counter with its Up and Down pulses both coming from external inputs. The Counter Pulse signal from Counter 1 is used as an input to Counter 2. Counter 1's Up and Down external signals each transition once but the transition edges are only 0.5 μ s apart, producing two pulses 0.5 μ s apart. In this example, the second counter pulse would not be seen by Counter 2.

Counter Clock Type

Each counter can be configured to interpret its Count Inputs in one of these ways:

- Up or Down mode, Type A Counter only
- Up/Down mode
- Clock/Direction mode
- A Quad B mode

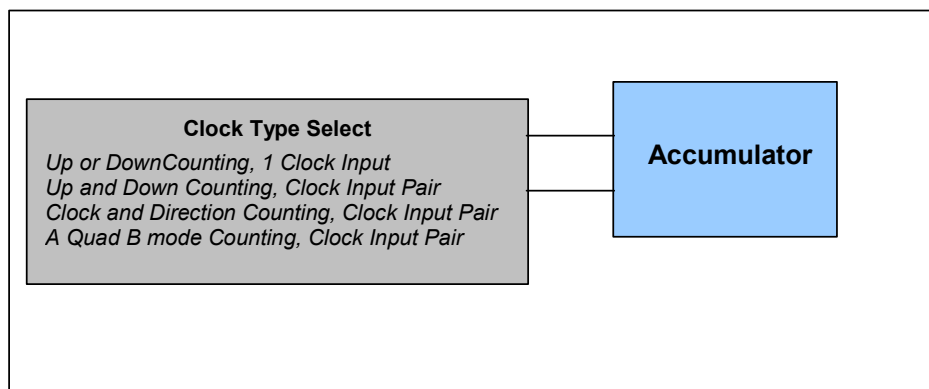

Up or Down Counting, Type A Counter Only

The Clock Input of a Type A Counter can be configured to count either Up or Down. The source of the Clock Input can be an external input, an external output, the module's internal oscillator, or the Counter Pulse of another counter in the module.

For an Up Counter, each occurrence of the Clock Input increments the Accumulator value, as shown below. For a Down Counter, each occurrence of the Clock Input decrements the Accumulator value (not shown).

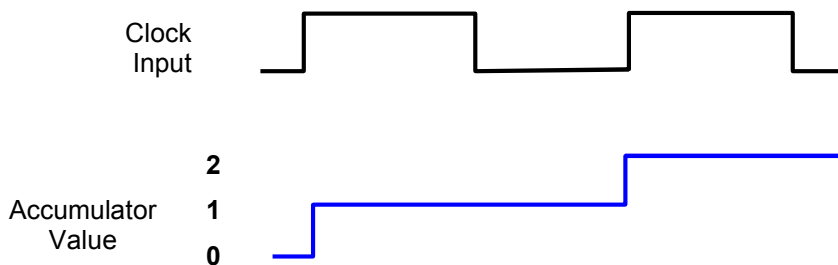

Up/Down Counting

When a pair of Clock Inputs is configured in Up/Down mode, the Up Input increments the Accumulator and the Down Input decrements the Accumulator. Simultaneous Up and Down Inputs do not change the Accumulator.

The source of the Up Input or the Down Input can be an external input, an external output, the module's internal oscillator, or the Counter Pulse of another counter in the module.

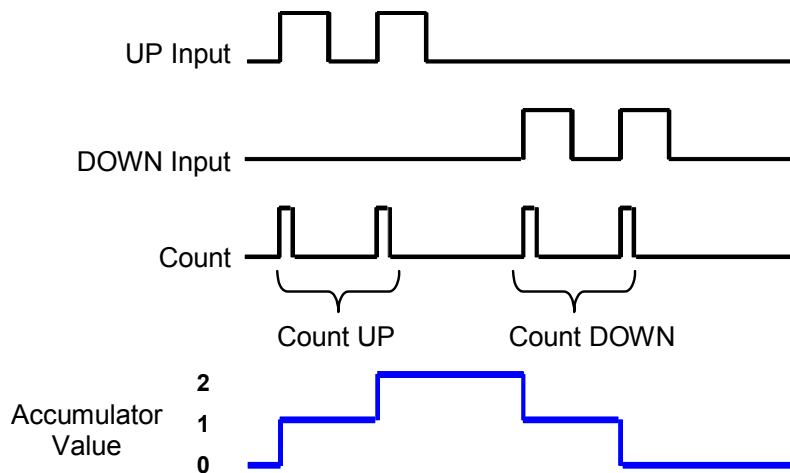

Clock/Direction Mode

When a pair of Clock Inputs is configured in Clock/Direction mode, the Clock Input updates the Accumulator value in the direction indicated by the Direction Input. The Direction Input should NOT be changed at the same time as the Count Input.

The source of the Clock Input can be an external input, an external output, the module's internal oscillator, or the Counter Pulse of another counter in the module.

The source of the Direction Input can be an external input, an external output, or a Control Data Reference. Any of these Direction sources can be used to control and change the up/down count direction. If the count direction should always be either up or down and not change during operation, that can be set up in the configuration.

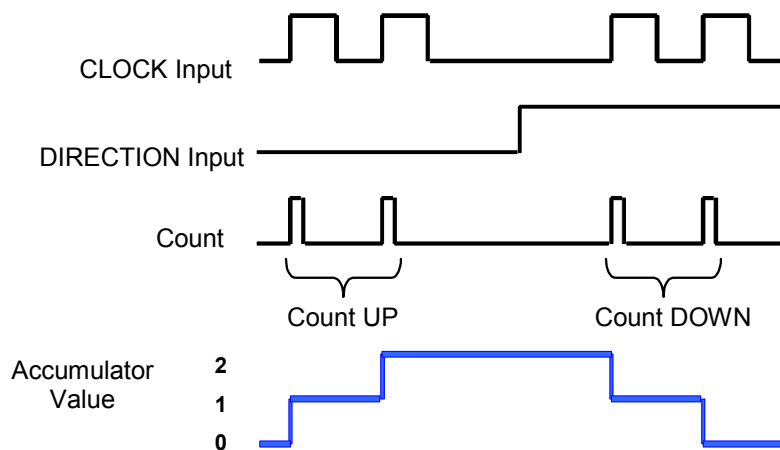

A Quad B Mode

When a pair of Clock Inputs is configured in A Quad B mode, a count occurs for each transition of either A or B. If the A input leads the B input, the Accumulator is incremented and if the B input leads the A input the Accumulator is decremented.

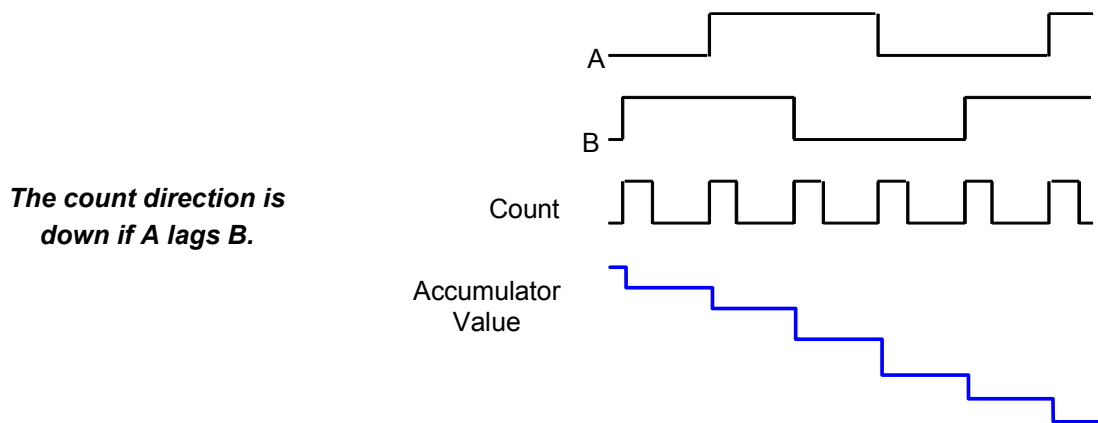
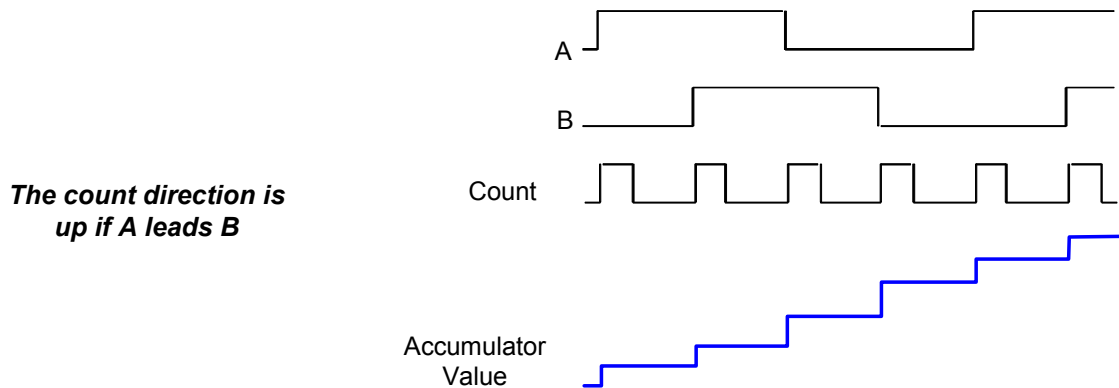

The source of an A Input or B Input can be an external input or an external output.

Ordinarily, the sources used for A Quad B mode are two external inputs from an A Quad B encoder. The wiring of the inputs determines which is the A input and which is the B input. In this type of application, the counts are evenly-spaced with respect to the input waveforms when the phase relationship between A and B is shifted by 1/4 cycle. A Quad B counting can be selected with other types of input signals, but unexpected results may occur.

The maximum count rate for A Quad B mode is 1.5MHz.

Quadrature Error

In A Quad B mode, simultaneous transitions on both inputs of a pair generate a quadrature error. Each counter has an Encoder Fault bit that indicates quadrature error detection. If a quadrature error occurs, outputs controlled by the counter do not default. There is no acknowledgement for the error.

Counting with Four Clock Inputs

The Type C Counter has two *pairs* of Clock Inputs. The User –Defined Counter can optionally be configured to have two pairs of Clock Inputs. Clock Inputs 1 and 2 are the positive loop and Clock Inputs 3 and 4 are the negative loop. The result for each loop is an up or down count direction and value. The Accumulator combines the direction and count from the positive loop with the direction and count from the negative loop.

Count Direction		Accumulator Value Result
+ Loop	- Loop	
Up	Up	Differential (Positive Loop – Negative Loop)
Up	Down	Additive (Positive Loop + Negative Loop)
Down	Up	Additive – (Positive Loop + Negative Loop)
Down	Down	Differential (Negative Loop – Positive Loop)
Up	no connection	Counts Up (Positive Loop)
Down	no connection	Counts Down (- Positive Loop)
no connection	Up	Counts Down (- Negative Loop)
no connection	Down	Counts Up (Negative Loop)

The diagram below shows Differential Counting when both the Positive Loop and Negative Loop of the Type C Counter are configured for A Quad B operation. Each input pair can also be configured for Up/Down or Pulse/Direction Count Mode.

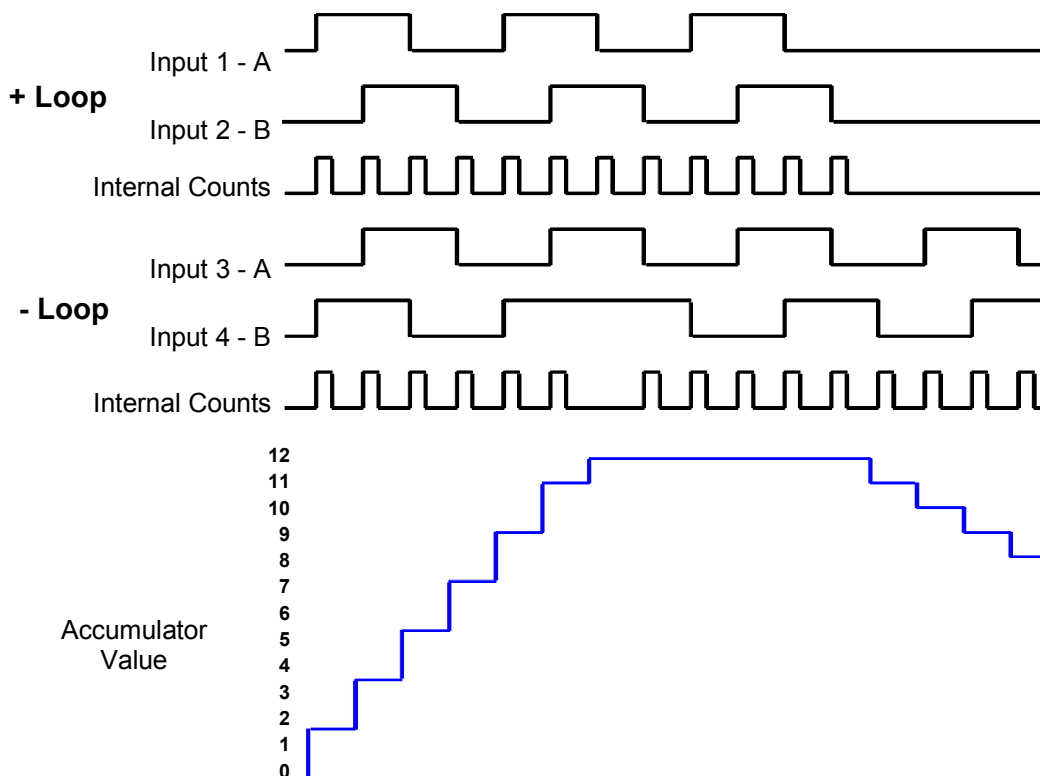

Counts per Timebase Register

The Counts per Timebase register is used to measure the rate of counting. It contains the number of counts received on the Clock Input in the previously-completed timebase interval. The Timebase counter updates once each Timebase period. After powerup, or any disruption in counting, allow at least one timebase period for the counter to stabilize.

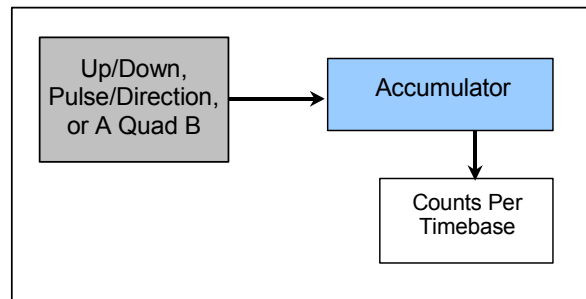

If more counts are received than can be stored in the register, the register overflows. The range depends on the selected timebase units:

Timebase units = 1ms	Range = 1 to 429496
Timebase units = 1 μ s	Range = 1 to 429496729
Timebase units = 100ns	Range = 1 to 2147483647

The module automatically provides the value in the Counts per Timebase register to the CPU as part of its regular input data.

Changes to the timebase do not take effect until after the previous timebase and one new timebase have elapsed. The configured timebase can be changed during operation using the Load Timebase command.

Rate of Change Monitoring

The value in the Counts per Timebase register can be used to compare the Accumulator's rate of change to a configured threshold value.

- If the configured Rate of Change value is positive and the counter counts in the positive direction so that the Counts per Timebase value becomes greater than the Rate of Change value, the Rate of Change status bit is set.
- If the configured Rate of Change value is negative and the counter counts in the negative direction so that the Counts per Timebase value drops to less than the Rate of Change value, the Rate of Change status bit is set.

The Rate of Change status bit remains set as long as Counts per Timebase value lies beyond the Rate of Change limit. The optional Rate of Change interrupt and/or fault is triggered once each time the Counts per Timebase crosses the Rate of Change threshold and exceeds the Rate of Change limit value.

Counter Preloads

Preloads are used to reset the Accumulator to a specific value. Type A, Type B, Type E, and Type Z Counters provide one Preload Register and a corresponding Preload Input. The Type C Counter provides two Preload Registers and Preload Inputs. The User-Defined Counter Type provides three or four of the internal counter's Preload Registers and corresponding Preload Inputs. (If the Homing feature of a User-Defined Counter is enabled, three Preloads are available. If Homing is not enabled, four Preloads are available). The Type D Counter has no Preload features.

Preload Priorities

When a Preload Input activates, the Preload value in the corresponding internal Preload register is copied to the counter Accumulator and the status bit is set. If Preload, Strobe and Clear all occur at the same time, the order of execution is: 1. Strobe, 2. Preload, 3. Clear.

The Type C and User-Defined Counter have more than one Preload Register. If multiple Preload Inputs occur on the same counter simultaneously, only the lowest-numbered Preload Register is copied into the Accumulator and has its status bit set. Any higher-numbered Preload Input that has occurred at the same time is ignored.

Preload Sources

A Preload can be triggered by any of the following:

- Any of the Preload Input Sources shown below. The Preload input can be configured as edge-sensitive or level-sensitive. Its polarity is also configurable. In the example below, when the Preload Input activates, the counter loads the value 156 from the Preload Register into the Accumulator.

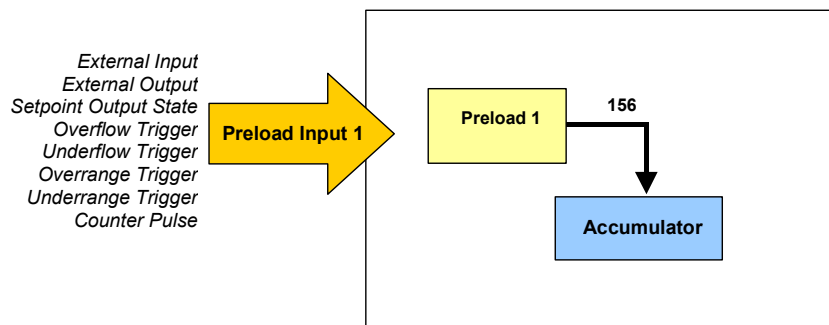

- The counter decrementing to zero in Continuous mode (Type E Counter only).
- The application program, which can send a Preload trigger in the counter's output data. This type of operation is an alternative to the Preload Input operation described above. Instead of choosing one of the Preload Input sources listed in the illustration above, the configured Preload Input source should be Control Data Reference.

Preload Status Bit and Preload Acknowledge Bit

The module sets the corresponding Preload Status bit when any Preload occurs. During operation, the application program can monitor the Preload Status bit (see chapter 6). When the Preload input is activated, the counter will automatically load the configured Preload value into the accumulator and set the corresponding Preload status bit. If the counter should be reset to zero, use 0 as the Preload value; this is the default value. The Preload Acknowledge bit must be set by the application program to clear the Preload Status bit.

If the Preload Acknowledge bit is already set at the time the Preload is triggered, the Preload Status bit is cleared instantly, so it is not seen by the application program. The Preload Input always Preloads the Accumulator regardless of the state of the Preload Status or Preload Acknowledge bit.

Preload Value

The Preload value can be any 32-bit value. A Preload value can be set up in the counter configuration. The Preload Value can also be changed as needed using a data command in the application program (see chapter 6).

Preload Disable

The User-Defined Counter Type provides a Preload Disable input that can inhibit Preload operation. Preload disable can be configured to come from the application program or from any external module input or output, and polarity is configurable. The Preload disable input is level-sensitive. Any counter that needs a Preload Disable input should be configured as a User-Defined Counter. See chapter 4 for more information.

For other Counter Types, if the Preload Source is set to Control Data Reference, the CPU can temporarily suspend use of the Preload-triggering reference by setting the counter's Preload Trigger output bit to 0. As long as that output bit is 0, the assigned Control Data Reference will have no effect on the Preload Register.

Counter Strobe Registers

A Strobe Register stores a copy of the count value that was in the Accumulator when the Strobe occurred. Type A, and Type B provide one Strobe Register and corresponding Strobe Input. The Type C Counter provides three. The Type E Counter uses sequenced strobes with one Strobe Input and four Strobe Registers. The User-Defined Counter Type provides all four of the internal counter's Strobe Registers and corresponding Strobe Inputs. The Type D and Type Z Counters have no Strobe features.

The value in a Strobe Register is automatically sent to the CPU as part of the module's regular input data.

Strobe Triggers

A Strobe can be triggered by:

- Any of the Strobe Input sources shown below. Each time a Strobe Input transition occurs, the module copies the current value in the counter Accumulator into the corresponding Strobe Register. Strobe Registers can be configured to be overwritten by new data, or to ignore new data until acknowledged,

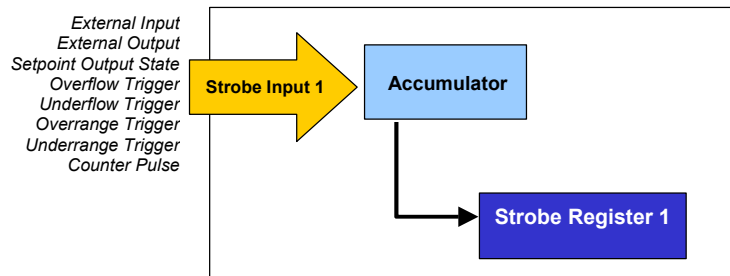

- A command from the application program. Instead of configuring one of the Strobe Input sources listed in the illustration, the Strobe Input source is configured as Control Data Reference.

For all counters, if Preload, Strobe and Clear all occur at the same time, the order of execution is: 1. Strobe, 2. Preload, 3. Clear.

Strobe Status Bit

When any Strobe occurs, the module sets a Status bit. The application program in the CPU can acknowledge receipt of the strobe by toggling the Strobe Acknowledge bit. If the Strobe Acknowledge bit is already set when the Strobe occurs, the Strobe bit is cleared instantly, so it is never seen by the application program.

- If the counter is configured for *Strobe Overwrite without Acknowledge*, the Strobe Input pulse always updates the Strobe register with the Accumulator value regardless of the Strobe Status bits.
- If the counter is configured for *Strobe Overwrite with Acknowledge*, the first strobe is captured. Subsequent Strobe Input pulses to the counter are ignored until the Strobe Status bit is cleared by setting the corresponding Strobe Acknowledge bit as mentioned above. See chapter 6 for more information.

Strobe Disable Input

The Type E and User-Defined Counter Types have a Strobe Disable input that suspends use of all of the counter's Strobe Inputs. The Strobe Disable input can be any of the source types shown for the Strobe Input. The Strobe Disable input is level-sensitive. Any counter that requires this type of Strobe Disable input should be configured as a User-Defined Counter.

For other Counter Types, if the Strobe Source is set to Control Data Reference, the CPU can temporarily suspend use of the Strobe-triggering reference by setting the counter's Strobe Trigger output bit to 0. As long as that output bit is 0, the assigned Control Data Reference will have no effect on the Strobe Register.

If a counter has a Strobe configured to occur on the rising or falling edge of an event and a Strobe Disable that is sensitive to the level that is present after that rising or falling edge, the Strobe Disable will prevent the Strobe from ever occurring. For example, if a Strobe is configured to occur when an external output goes ON and the counter's Strobe Disable is configured to be active when the same input is ON, the Strobe will never occur.

Sequenced Strobing

The Type E and User-Defined Counter Types can be set up for Sequenced Strobing. When Sequenced Strobing is Enabled, four Strobe Registers are controlled by Strobe Input 1. In Sequenced Strobing, the Accumulator value is copied into the first available (status = acknowledged) Strobe Register. The application program needs to manage reading the data and acknowledging Strobe events so that additional data can be stored.

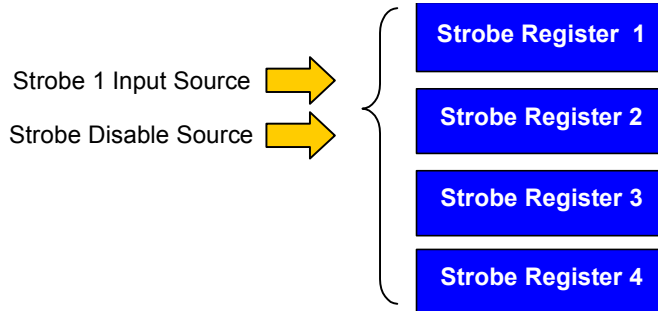

Compatibility Note: Series 90-70 and Series 90-30 High-Speed Counter modules use a single strobe %Q bit to reset all Strobe Registers. To fully-reset the four Strobe Registers of an RX3i High-Speed Counter module Type E or User-Defined Counter, all four Strobe Acknowledge bits must be set (see chapter 6).

Strobe Register Resets

Preloading the counter's Accumulator automatically resets the Strobe Status bits.

If a Type E or User-Defined Counter is configured for both Sequenced Strobing and Continuous counting, and also uses the special Preload/Strobe Acknowledge, all four Strobe registers are reset and all four Strobe Status bits are cleared when the counter decrements to 0 and performs the automatic Preload.

If a Strobe occurs just before a Preload, the strobed value is stored in the next available Strobe register. However it is possible that the Strobe status will be reset before the Strobe Status bit has been updated in the CPU.

Counter Setpoints

Each external output on the module can be controlled either by the application program or by a pair of Setpoint values. Setpoints are Accumulator values at which the counter's associated Setpoint Outputs will go ON and OFF.

Each Counter Type has four pairs of 32-bit on/off Setpoint registers, and up to four Setpoint outputs.

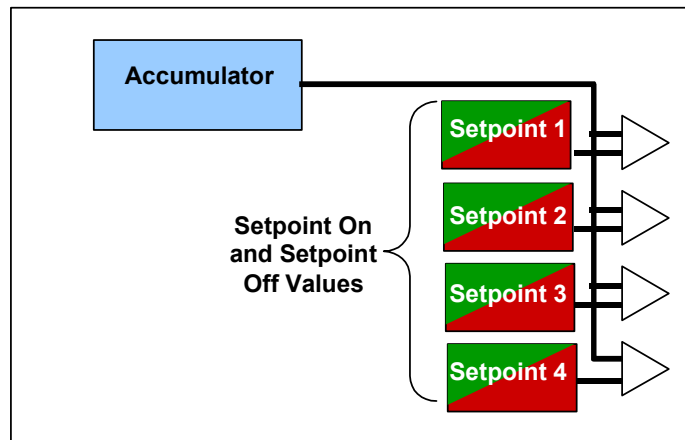

If an external output should always be controlled by the value in the counter Accumulator, its Output Source should be configured as Setpoint(s).

Operation of a Setpoint Output

Depending on the relationship between the Setpoint On and Off values, the output may be either on or off when the Accumulator value lies between them.

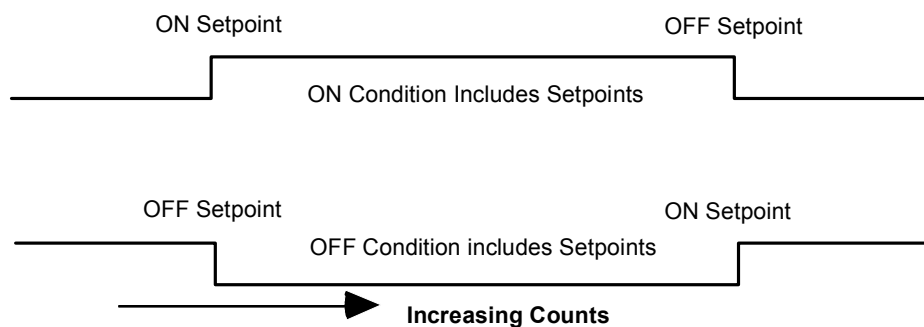

- If a pair of Setpoint Limit values is equal, the Setpoint is On for one Accumulator value only.
- If the ON Setpoint is less than the OFF Setpoint, the ON condition includes the Setpoint values.
- If the OFF Setpoint is less than the ON Setpoint, the OFF condition includes the Setpoint values.

The module's external outputs can be assigned more than one pair of Setpoints. If that is done, the Setpoint signals are logically OR-ed before being output. This function can simulate a cam operation with multiple lobes per revolution.

Setpoint On and Off Values

When the Accumulator value lies between or is equal to the Setpoints, the output ON/OFF state is always that of the lowest (most negative) Setpoint. When the Accumulator value is *not* between the Setpoints, the output ON/OFF state is that of the most positive Setpoint. This is true regardless of the counter direction. For example, if the Setpoint OFF value is higher than the ON value as shown below, the output is always Off when the Accumulator value does not lie with the Setpoints.

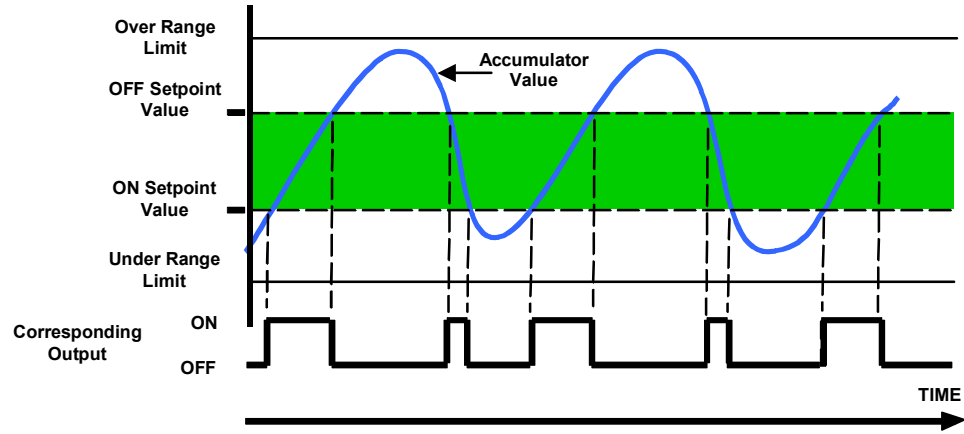

The operation shown above holds true whether the setpoints lie within or outside of the configured counter range. In Continuous Within Range count mode, the output may switch when wraparound occurs (if one of the setpoints lies beyond the configured range).

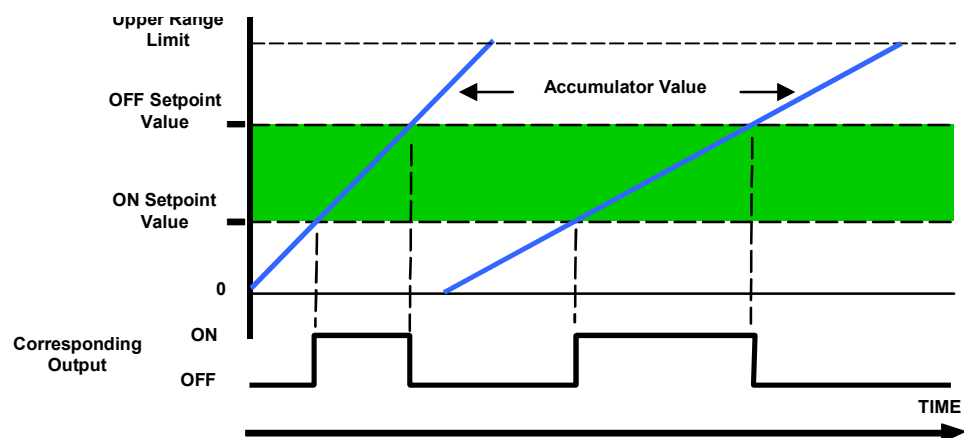

If neither of the Setpoints is within the counter range, the output state does not change; it is always the state of the most positive Setpoint. If both Setpoints are equal and out of range, the output is always OFF. If both Setpoints are equal and within the counter range, the output is on for only one count value – as defined by the Setpoints.

Setpoint Interrupts

Interrupts can be individually enabled or disabled for each Setpoint output's ON and OFF transition. See chapter 7 for information about using Interrupts.

Simultaneous Setpoint changes generate only one interrupt to the CPU, so the counter's updated input bit data must be used by an interrupt routine to determine which Setpoints changed state and which edge(es) generated the interrupt.

Separation of Setpoints

There is no minimum interval required between setpoints on an RX3i High-Speed Counter module.

It is possible that an external setpoint pulse may be too brief for an external output driver to drive the pulse. Output delay times are listed on page 1-3.

This chapter describes the different types of High-speed Counter Types that can be set up for with PACSystems RX3i High-speed Counter modules:

- **Type A:** a simple Up or Down counter with one clock input.
- **Type B:** a simple counter that uses a pair of clock inputs to perform Up/Down, Pulse/Direction, or A Quad B counter. Type B provides a Disable input to suspend counting.
- **Type C:** a complex counter that uses two pairs of clock inputs to perform Up/Down, Pulse/Direction, A Quad B, or differential counting. Type C provides a Disable input that can be used to suspend counting. In addition, the Type C counter provides Home Marker and Home Switch inputs and a Home Position preload register, making it suitable for applications requiring motion control or homing capability.
- **Type D:** a simple counter that uses a pair of clock inputs to perform Up/Down, Pulse/Direction or A Quad B counting. Type D provides basic homing capability with a Home Marker and Home Position preload register. It lacks the Home Switch input and Disable input of a Type C counter.
- **Type E:** a complex counter that counts down from a configured Preload value to zero. At zero, the counter turns on a Response Output Point. Other features of the Type E Counter include Sequenced Strobing, Counter Disable, and Strobe Disable.
- **Type Z:** a simple counter that uses a pair of clock inputs to perform Up/Down, Pulse/Direction, or A Quad B Counting. Type Z provides a special Clock Z Input that combines the functions of a Strobe input (copies the current count value to a Strobe register), Disable input (optionally suspends counting), and Clear input (optionally resets the Accumulator to zero).
- **User-Defined:** a versatile counter type that provides all elements of one of the module's internal counters. A User-Defined counter can be used to create a custom counter type. Its features include a Clear Input, Home Marker and Home Switch Inputs, optional differential counting, and Sequenced Strobing.

Type A Counter

The RX3i Type A Counter uses one of the High-Speed Counter Module's internal counters. The Type A counter has:

- One Clock Input that can be configured to count either up or down to increment or decrement the count value in the Accumulator.
- One Preload Input (with one Preload register) that can be used to set the Accumulator to a configured Preload Value.
- One Strobe input (with one Strobe register) that can be used to store a copy of the Accumulator value.
- A Counts per Timebase register that captures the current count rate.
- Up to four Setpoint On/Off values that can control external output points.

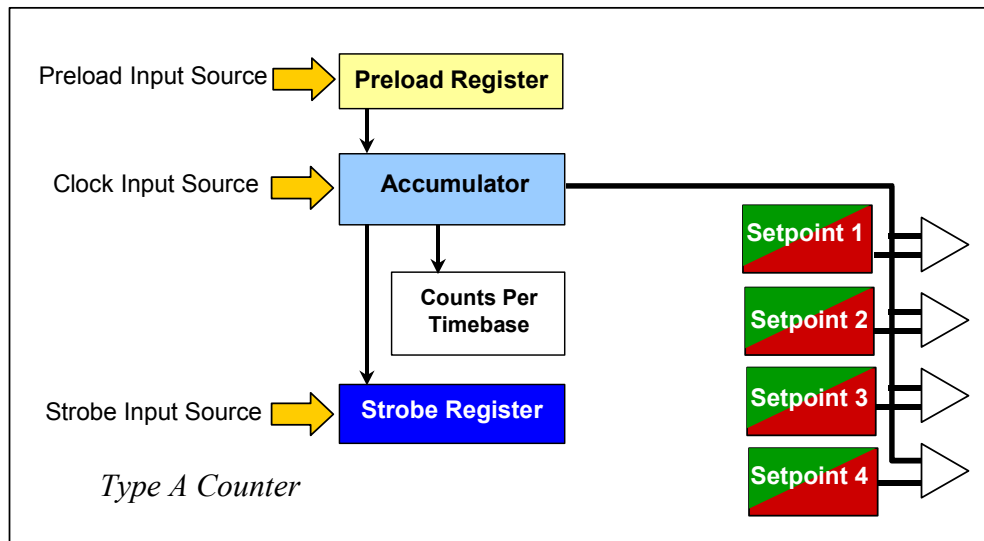

Additional configurable features of a Type A Counter are:

- Timebase Units
- Prescale Divider, used to scale down high count rates
- Strobe Overwrite with or without Acknowledgement
- Continuous or One-Shot Count Mode, either within or beyond the counter's Range Limits
- High Range and Low Range Limits
- Rate of Change monitoring
- Fault Reporting
- Interrupts

Please see chapter 3 for descriptions of these High-Speed Counter features.

Type B Counter

An RX3i Type B Counter uses one of the High-Speed Counter Module's internal counters. The Type B counter has:

- Two Clock Inputs that work together to increment or decrement the count value in the Accumulator. Configurable for Up/Down, Pulse/Direction or A Quad B counting.
- One Preload Input (with one Preload register) that can be used to set the Accumulator to a configured Preload Value.
- A Counter Disable input that can suspend updating the count value in the Accumulator.
- Two Strobe inputs (with two Strobe registers) that can be used to store copies of the Accumulator value.
- A Counts per Timebase register that captures the current count rate.
- Up to four Setpoint On/Off values that can control external output points.

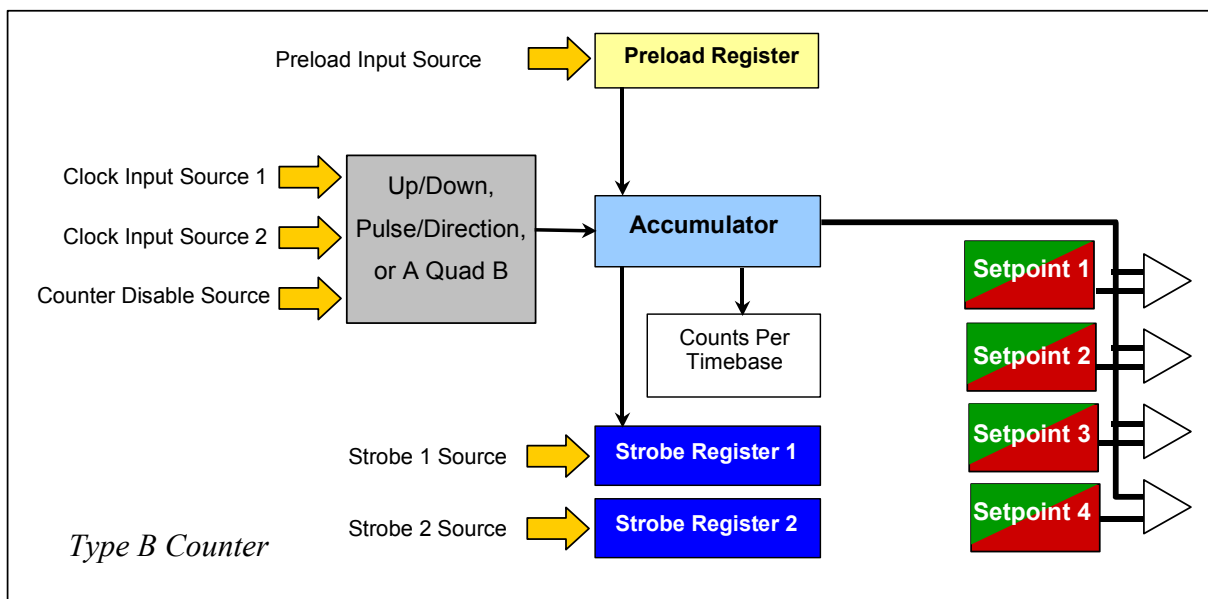

Additional configurable features of a Type B Counter are:

- Timebase Units
- Prescale Divider, used to scale down high count rates
- Strobe Overwrite with or without Acknowledgement
- Continuous or One-Shot Count Mode, either within or beyond the counter's Range Limits
- High Range and Low Range Limits
- Rate of Change monitoring
- Fault Reporting
- Interrupts

Please see chapter 3 for descriptions of these High-Speed Counter features.

Type C Counter

An RX3i Type C Counter is a complex counter that uses one of the High-Speed Counter module's internal counters. The Type C counter has:

- Four Clock Inputs that work as two pairs to increment or decrement the count value in the Accumulator. Up/Down, Pulse/Direction, A Quad B, or differential counting.
- Two Preload Inputs (with two Preload Registers) that can be used to set the Accumulator to a configured Preload Value.
- Home Switch input, Home Marker input, and Home Position register for applications requiring motion control or homing capability.
- A Counter Disable input that can suspend updating the count value in the Accumulator.
- Three Strobe inputs (with three Strobe registers) that can be used to store copies of the Accumulator value.
- A Counts per Timebase register that captures the current count rate.
- Up to four Setpoint On/Off values that can control external output points.

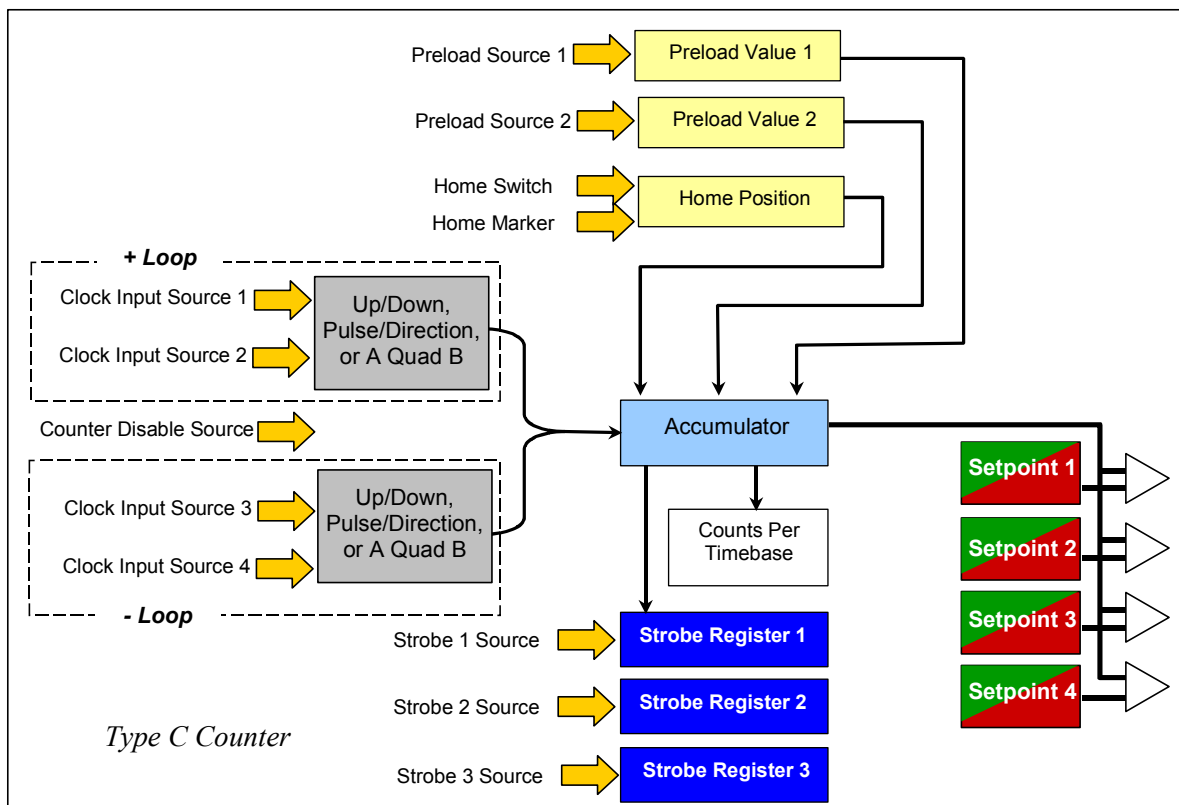

Additional configurable features of a Type C Counter include:

- Timebase Units
- Prescale Divider, used to scale down high count rates
- Strobe Overwrite with or without Acknowledgement
- Continuous or One-Shot Count Mode, either within or beyond the counter's Range Limits
- High Range and Low Range Limits
- Rate of Change monitoring
- Fault Reporting
- Interrupts

Please see chapter 3 for descriptions of these High-Speed Counter features.

Note that the maximum count rate for a Type C counter is 750kHz per clock input loop.

Homing Operation of a Type C Counter

During configuration, a Home Position Value is set up for the Type C Counter. It can be any value within the counter's high and low limits. The Home Switch Input and the Home Marker Input are individually set up to be triggered by an external input or output, a Setpoint Output, the count pulse of any counter on the module, or an over/underflow or out of range condition of the Accumulator.

During operation, the application program starts a Home Cycle by setting the Home Command bit in the module's output data (details are in chapter 6). Once the Home Cycle starts, the occurrence of the Home Marker Input while the Home Switch Input is active completes the Home Cycle. The module places the configured Home Position value into the Accumulator. After completing the cycle, the module sets a Home Found input bit, which is returned to the CPU. The bit remains set until the next use of the Home Command output bit.

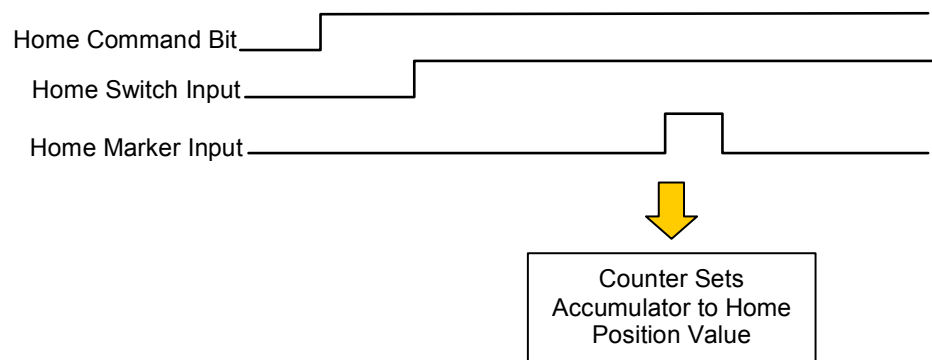

Additional markers are ineffective until the Home Command is removed and the Home Command sequence is repeated. If the Home Command is removed before the Home marker is found, a **Home Error** is returned.

The Home Cycle has precedence over the counter's two Preloads. If a Home Cycle completes simultaneously with any Preload input, the Accumulator is set to the Home value.

Type D Counter

The RX3i Type D Counter uses one of the module's internal counters. The Type D Counter has:

- Two Clock Inputs that work together to increment or decrement the count value in the Accumulator. Configurable for Up/Down, Pulse/Direction, or A Quad B counting.
- One Home Marker Input (with one Home value register) for basic homing capability.
- A Counts per Timebase register that captures the current the count rate.
- Up to four Setpoint On/Off values that can control external output points.

Type D is suitable for applications requiring simple homing capability.

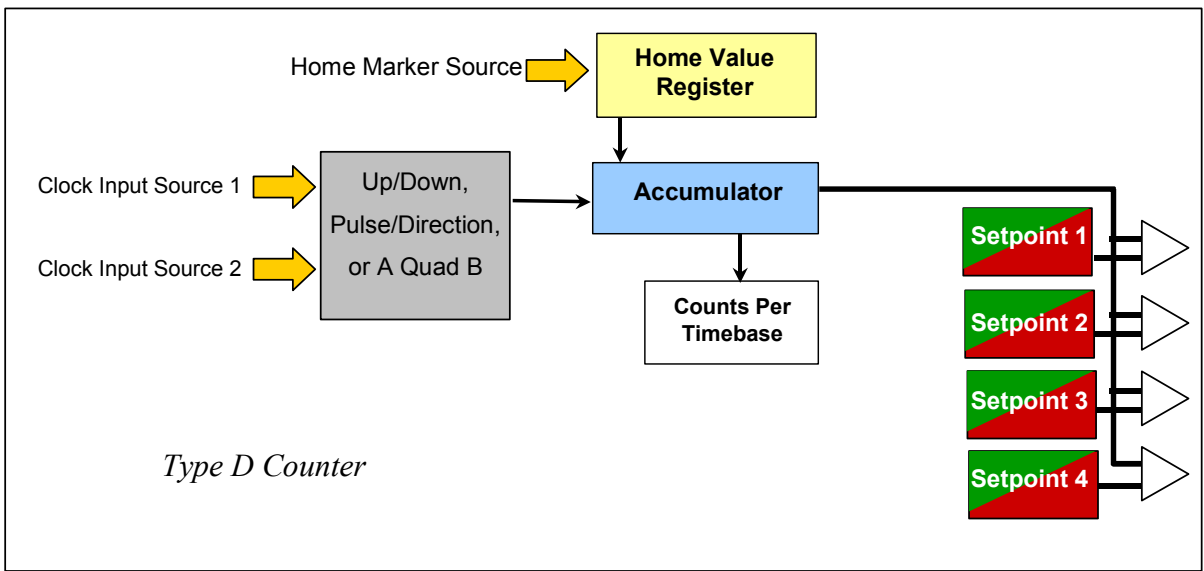

Additional configurable features of a Type D Counter are:

- Timebase Units
- Prescale Divider, used to scale down high count rates
- Continuous or One-Shot Count Mode, either within or beyond the counter's Range Limits
- High Range and Low Range Limits
- Rate of Change monitoring
- Fault Reporting
- Interrupts

Please see chapter 3 for descriptions of these High-Speed Counter features.

Homing Operation of a Type D Counter

During configuration, a Home Position Value is set up for the Type D Counter. It can be any value within the counter's high and low limits. The Home Marker Input is set up to be triggered by an external input or output, a Setpoint Output, the count pulse of any counter on the module, or an over/underflow or out of range condition of the Accumulator.

During operation, the application program starts a Home Cycle by setting the Home Command bit in the module's output data (details are in chapter 6). Once the Home Cycle starts, the occurrence of the Home Marker Input completes the Home Cycle. The module places the configured Home Position value into the Accumulator. After completing the cycle, the module sets a Home Found input bit, which is returned to the CPU. The bit remains set until the next use of the Home Command output bit.

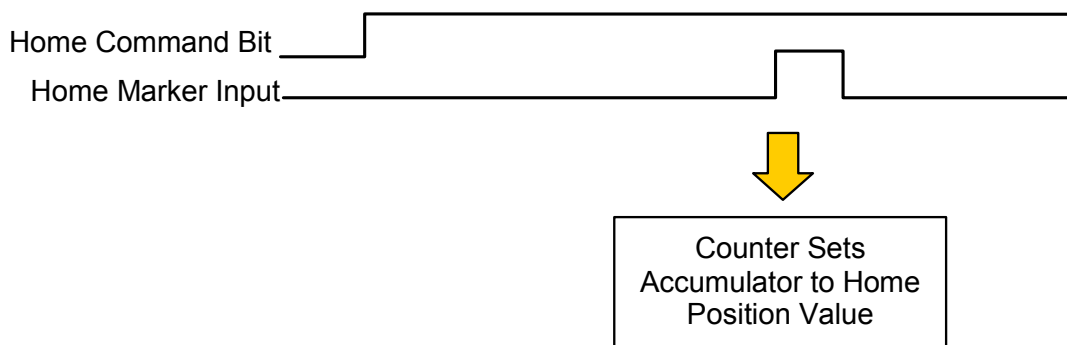

If the Home Command bit is cleared before a Home Marker transition is encountered, a Home error is generated and the Home Cycle is ended. When a Home Cycle is not in progress, the Home Marker input is ignored.

In addition to monitoring the Home Found status bit and setting the Home Command output bit, the application program can also change the Home Position value. This does not change the configured Home Position value, as explained in chapter 6.

Type E Counter

An RX3i Type E Counter uses two of the High-Speed Counter module's internal counters. Type E is a specialized counter that counts down from a Preload value to zero. When the down count reaches zero, a Response Output Point is energized. The Type E Counter has:

- Two Clock Inputs for Up/Down, Pulse/Direction, or A Quad B counting.
- Two Preload Inputs (with two Preload Registers). Preload 1 is a normal Preload that can be used to set the Accumulator to a configured value at any time, as appropriate for the application. Preload 2 is the starting Accumulator value, from which the Type E Counter counts down. Operation is described on the next page.
- A Counter Disable input that can suspend updating the count value in the Accumulator.
- One Strobe input (accesses four Strobe registers using optional Sequenced Strobing).
- A Strobe Disable input that can suspend writing the count value to a Strobe register.
- Count Down to Zero Pulse.
- A Counts per Timebase register that captures the current count rate.
- Up to four Setpoint On/Off values that can control external output points.
- Response Output point with configurable On time and Pulse or Latch mode operation.

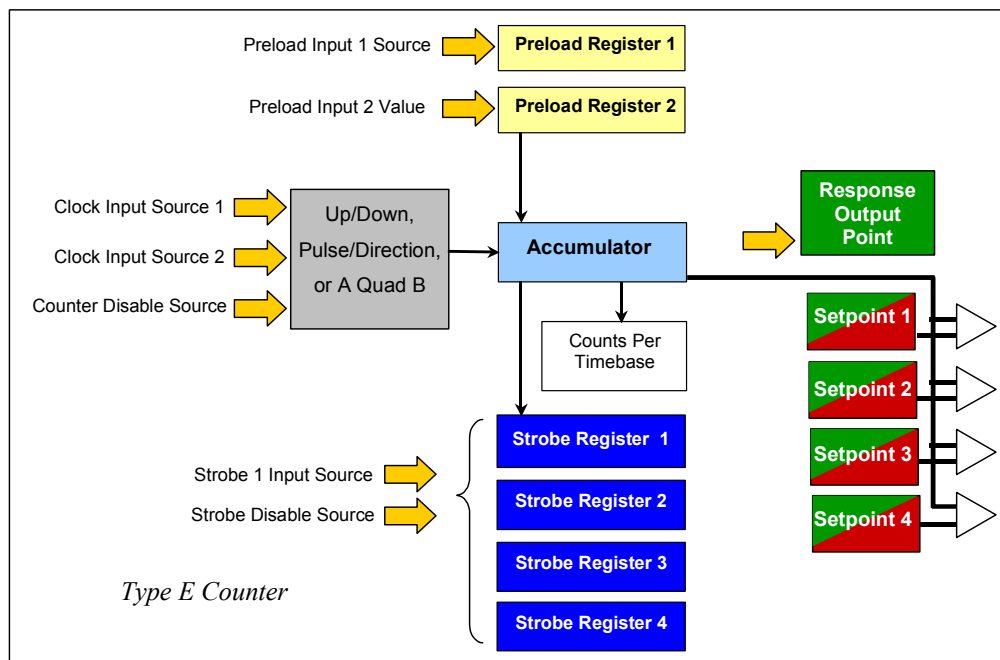

Additional configurable features of a Type E Counter are:

- Timebase Units
- Prescale Divider, used to scale down high count rates
- Continuous or One-Shot Count Mode, either within or beyond the counter's Range Limits
- High Range and Low Range Limits

- Rate of Change monitoring
- Fault Reporting
- Interrupts

Please see chapter 3 for descriptions of these High-Speed Counter features.

Operation of the Type E Counter

At powerup, the Accumulator of a Type E Counter is initialized to the Preload 2 value and begins counting down. When the Accumulator counts down to zero, the Response Output Point turns On. The Type E Counter accommodates momentary up counts, such as jitter on an A Quad B input. The Response Output Point is not energized if an upward count rolls the Accumulator value over to zero.

Count Mode for the Type E Counter

A Type E Counter is always configured for Count Down to Zero Pulse enabled on Setpoint 4.

If the Type E counter is configured for *Continuous* Count Mode, the counter automatically reloads itself with the Preload Value when it reaches zero, and continues counting down.

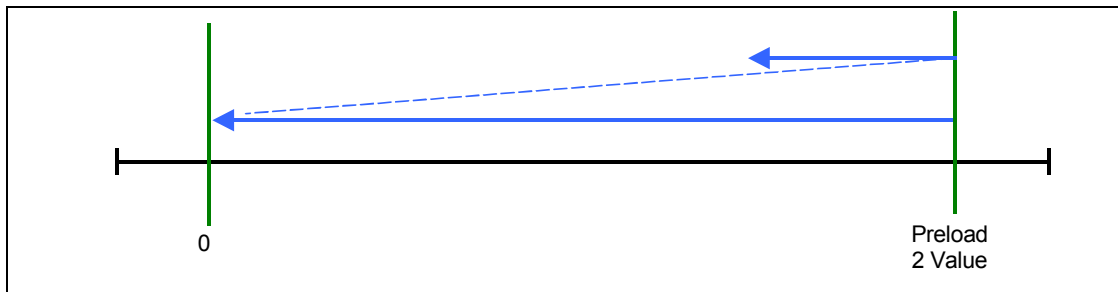

If the Type E Counter is configured for *One-Shot* Count Mode, the counter stops when it decrements to zero. Counting is enabled again when the counter is preloaded by Preload 1.

The Preload 2 value is set up during counter configuration (the source of the Preload 2 value is not configurable, only the value itself is configured). Subsequently, the Preload 2 value can be changed using a data command from the CPU. A new Preload 2 value does not affect counting until the counter decrements to zero in *Continuous* mode.

Note: Setpoint 4 asserts a signal for each count down to 0. To configure an I/O Interrupt for count down to 0, enable the Type E Counter's Setpoint #4 (ON) Interrupt.

Note: For a Type E Counter, the Preload 1 Value is for the configurable source Preload, while the Preload 2 Value is for the Automatic Preload when in Continuous Count mode. For applications requiring compatibility with existing GE Fanuc High-Speed Counter modules, both Preload 1 and Preload 2 should be set to the same value.

The Response Output Point

Operation of the Response Output Point depends on the counter's configured Count Mode and whether the Response Output Point is operating in Pulse Mode or Latch Mode.

If the counter is configured for *One-Shot* counting, the Response Output Point can operate in either *Latched Mode* or *Pulse Mode*. The output is energized once for the configured time (Output Milliseconds). For example, with the Preload 2 Value=5 and the Output Milliseconds=10:

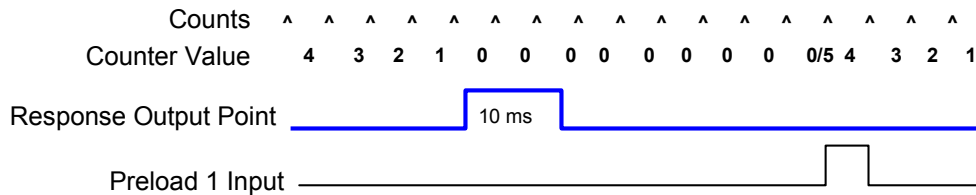

If the counter is configured for *Continuous* counting, the Response Output Point must be configured for *Pulse Mode*. The output pulses for the configured Output Milliseconds time each time the counter counts down to 0. The configured pulse duration must be less than the time required to count from the Preload 2 value down to zero. This allows the pulse time to turn Off before it is set again. For example, using the same values as above, with both the Preload 1 Value and the Preload 2 Value set to 5:

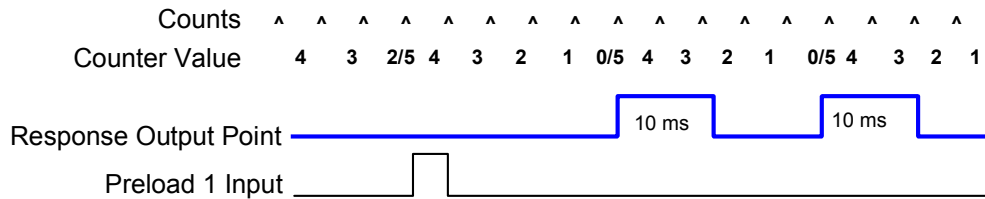

If the counter is configured for *One-Shot* counting and the Response Output Point is configured for *Latch Mode*, there is no Output time. The Response Output Point turns On when the count reaches 0, and stays On until a Preload 1 occurs. The Preload turns the output Off and it stays Off until the counter counts down to 0 again. For example:

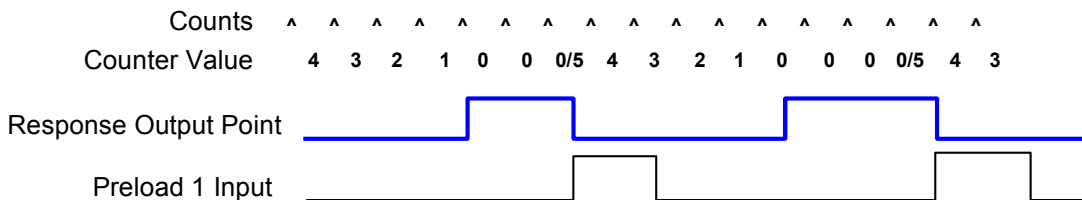

When a Response Output Point operates in *Latch* mode, if the Preload 1 Source is configured as Control Data Reference, the application program must trigger Preload 1 on both the counter number being configured (1, 3, 5, or 7) and the next counter number (2, 4, 6, or 8) to turn off the latched output.

Sequenced Strobing for the Type E Counter

Although the Type E Counter has just one Strobe Input, it can utilize four Strobe registers by configuring Sequenced Strobing as Enabled. In Sequenced Strobing, all four Strobe registers operate as a Strobe Event Stack controlled by Strobe Input 1 events.

When the Strobe Input 1 source is triggered, the current Accumulator value is stored in the first Strobe Register that has its Strobe Status bit set to 0. Initially, this is Strobe Register 1. For example, here the Count value 100 is copied into Strobe Register 1:

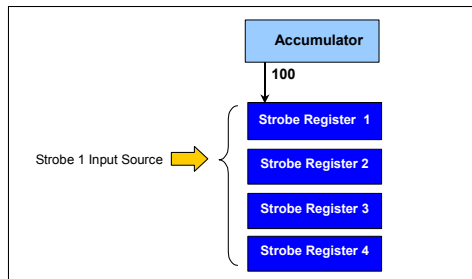

After reading the data from a Strobe Registers, the application program must clear its Strobe Status bit using the corresponding Strobe Acknowledge output bit. (If appropriate, this step can be eliminated by configuring the Sequenced Strobing parameter as: “Enabled – Preloads or Clear Acknowledge Strobe Status”.)

When subsequent strobos occur, the current Accumulator value is stored to the first available Strobe Register in the sequence. For example, here the Count value 900 is copied into the first available Strobe Register, which is Strobe Register 2. If all four Strobe Status bits are set, no additional stores are possible until one or more Strobe Status bits are cleared.

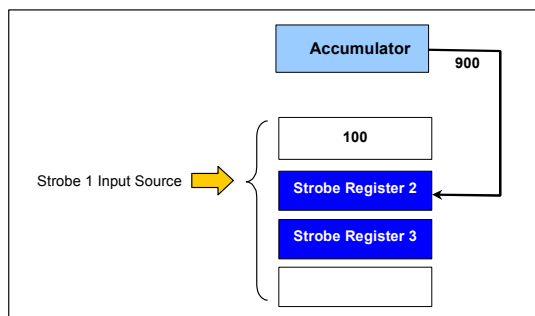

Note: The Series 90-70 High-Speed Counter uses one Strobe Acknowledge bit in the counter control data to acknowledge all four strobos. For equivalent functionality in an RX3i High-Speed Counter module, all four Strobe Acknowledge bits must be set concurrently to clear the Strobe Event Stack.

Type Z Counter

An RX3i Type Z Counter uses one of the High-Speed Counter Module's internal counters. The Type Z Counter has:

- Two Clock Inputs that work together to increment or decrement the count value in the Accumulator for Up/Down, Pulse/Direction, or A Quad B counting.
- One Preload Input (with one Preload register) that can be used to set the Accumulator to a configured Preload Value.
- A Clock Z Input that combines the functions of a strobe input, disable input (suspends counting) and clear input (resets the Accumulator to zero). When the Clock Z Input source is active, the Clock Z Input stores the current Accumulator value in the counter's Strobe 1 register. Optionally, the Clock Z Input can also be configured to disable counting while it is active, and/or to clear the Accumulator to zero (configured as Resume mode).
- A Counts per Timebase register that captures the current count rate.
- Up to four Setpoint On/Off values that can control external output points.

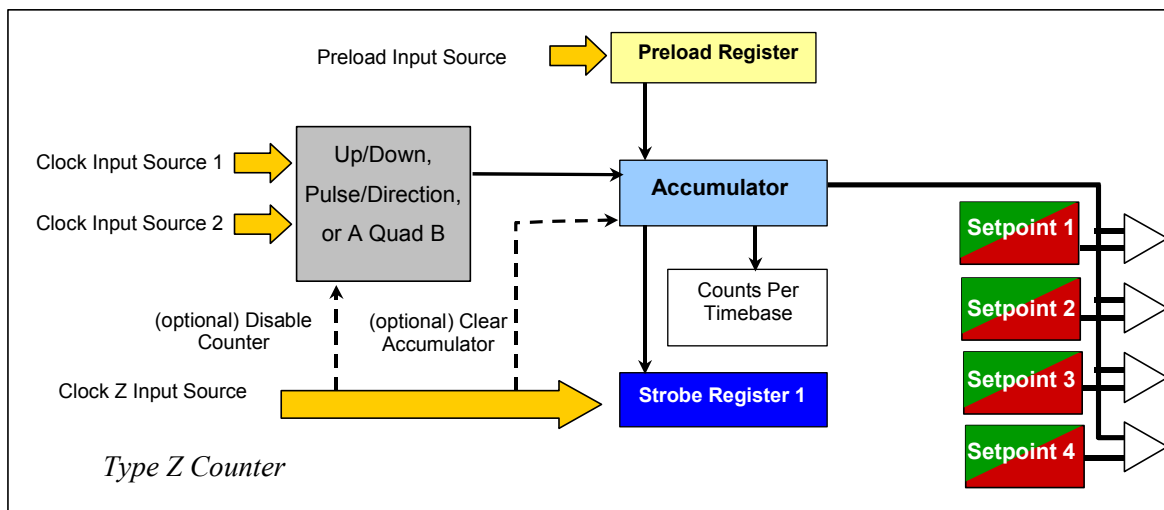

Additional configurable features of a Type Z Counter are:

- Timebase Units
- Prescale Divider, used to scale down high count rates
- Strobe Overwrite for the Clock Z Input, with or without Acknowledgement
- Continuous or One-Shot Count Mode, either within or beyond the counter's Range Limits
- High Range and Low Range Limits
- Rate of Change monitoring
- Fault Reporting
- Interrupts

Please see chapter 3 for descriptions of these High-Speed Counter features.

Operation of the Clock Z Input

The Type Z Counter is the only Counter Type with a Clock Z Input. This special input can be used to trigger a store of the current Accumulator value to the counter's Strobe 1 memory. Both the source and the polarity of the Clock Input Z are configurable. The stored count value is retained in memory until another store occurs.

In *Store/Continue* mode, Clock Input Z triggers a store and the counter continues counting.

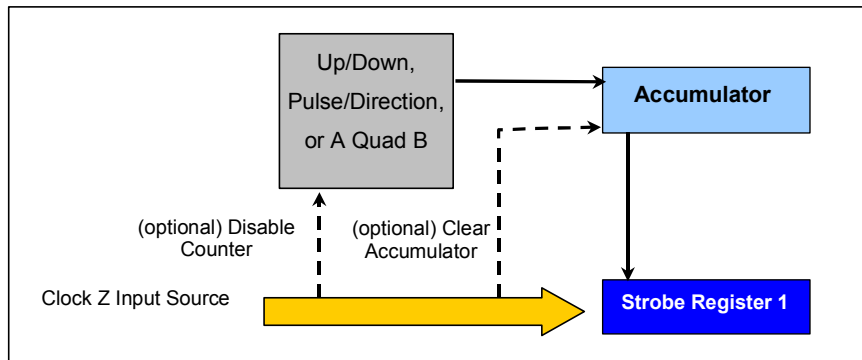

In *Store/Wait/Resume* mode, Clock Input Z triggers a store, but counting stops for as long as the selected Clock Input Z source remains in the configured Polarity. For example, if the source of the Clock Input Z signal is an Overflow condition on the module's Counter 2, when an overflow condition occurs on Counter 2, the Type Z counter will store the current value and stop. It will not resume counting until the Overflow fault is cleared.

In *Store-Reset/Wait/Start* mode, Clock Input Z triggers a store and resets the counter to zero. The counter stops counting for as long as the selected Clock Input Z source remains in its configured Polarity. For example, if the source of the Clock Input Z signal is Setpoint 1 of Counter 1, and the Polarity is selected to be Rising Edge/High Level, then when Counter 1 counts to its Setpoint 1 On value, the Type Z counter will store the current value and reset to zero. The Type Z counter will not start counting again until Counter 1 reaches its Setpoint 1 Off value.

In *Store-Reset/Start* mode, Clock Input Z triggers a store and resets the counter to zero, The counter immediately resumes counting. For example, if the source of the Clock Input Z signal is External Input #4 and the Polarity is set to be Falling Edge/Low Level, when Input 4 goes Off the Type Z counter will store the current value, reset to zero, and continue counting.

User-Defined Counter

An RX3i User-Defined Counter can be used to create a custom Counter Type. It provides all of the features of the predefined Counter Types except the Response Output Point of a Type E Counter. A User-Defined Counter uses one of the module's internal counters. The User-Defined counter has:

- One, two or four Clock Inputs that work together to increment or decrement the count value in the Accumulator. Up/Down, Pulse/Direction, A Quad B, or differential counting.
- Four Preload Inputs (with four Preload registers) that can be used to set the Accumulator to a configured Preload Value. (Only three Preloads are available if Homing is enabled).
- A Preload Disable Input. See chapter 3 for information.
- A Counter Disable input that can suspend incrementing or decrementing the count value in the Accumulator.
- A Clear Counter Input to reset the Accumulator.
- Count Down to Zero Pulse.
- Four Strobe inputs (with four Strobe registers) that can be used to store copies of the Accumulator value.
- A Strobe Disable Input.
- Sequenced Strobing.
- Home Switch Input, Home Marker Input, and Home Position register.
- A Counts per Timebase register that captures the current the count rate.
- Up to four Setpoint On/Off values for controlling external output points.

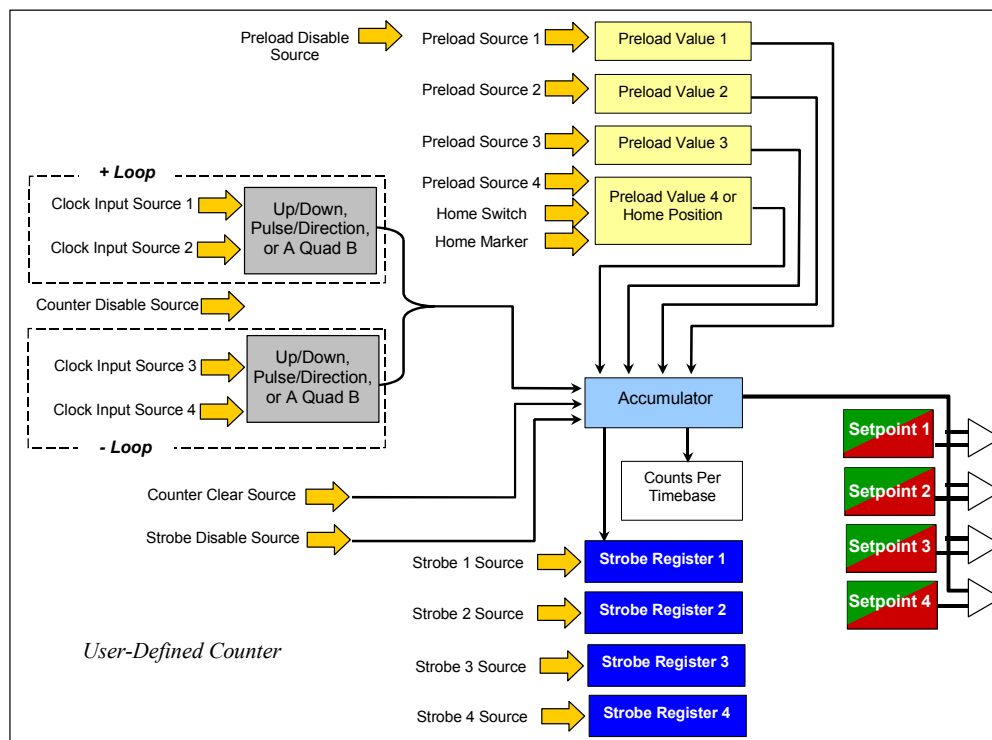

Additional configurable features of a User-Defined Counter are:

- Timebase Units
- Prescale Divider, used to scale down high count rates
- Strobe Overwrite with or without Acknowledgement.
- Continuous or One-Shot Count Mode, either within or beyond the counter's Range Limits
- High Range and Low Range Limits
- Rate of Change monitoring
- Fault Reporting
- Interrupts

Please see chapter 3 for descriptions of these High-Speed Counter features.

The Clear Counter Input

The User-Defined Counter is the only counter type that provides a Clear Input. Ordinarily, the Clear Input sets the Accumulator value to zero. If zero does not lie between the counter's configured High Range and Low Range values, the Clear Input sets the Accumulator to the configured Low Range value. For example:

<i>Under Range Value</i>	<i>Over Range Value</i>	<i>Clear Accumulator Value</i>
200	2147483647.	200
-2147483648	2147483647	0
-2147483648	-200	-2147483648

When the configured Clear source activates, the module immediately resets the Accumulator as shown above. The Clear source can be configured to come from any external module input or output, from a Setpoint Output state, an Under- or Overflow trigger, a High- or Low Range trigger, or a Counter pulse. Its polarity is configurable. If the Clear Counter command should come from the application program, the Clear source must be configured as Control Data Reference.

The Clear source can be configured as edge-sensitive or level-sensitive. When the Clear source is configured as level-sensitive, the counter Accumulator remains at the Clear Accumulator value while the Clear source is at a configured (high or low) level. When the Clear source is configured as edge-sensitive, the Accumulator is cleared at the active edge of the Clear signal, but is enabled for counting regardless of the logic level of the Clear source.

The Clear value is set up in the configuration. Changing the high range and low range values by commands in the module's output data will NOT change the Clear value.

If a Preload Input, Strobe Input, and Clear Input all occur simultaneously, the Preload, Strobe, and Clear actions are performed in that sequence.

Preload Disable

The User-Defined Counter is the only counter type with a Preload disable input that can inhibit Preload operation. Preload disable can be configured to come from the application program or from any external module input or output, and polarity is configurable. The Preload disable input is level-sensitive. Any counter that needs a Preload Disable input should be configured as a User-Defined Counter.

If the counter has a Preload configured to occur on the rising or falling edge of an event and a Preload Disable that is sensitive to the level that is present after that rising or falling edge, the Preload Disable will prevent the Preload from ever occurring. For example, if a Preload is configured to occur when an external output goes ON and the counter's Preload Disable is configured to be active when the same external output is ON, the Preload will never occur.

Homing Options for the User-Defined Counter

The User-Defined Counter type has the same homing features as a Type C Counter, described earlier in this chapter. The only difference for the User-Defined Counter is that the Homing feature can be enabled or disabled using the configuration counter tab option: Homing Feature.

Strobing Options for the User-Defined Counter

The User-Defined counter provides four Strobe Inputs, a Strobe Disable Input, and four Strobe Registers. Strobing operation depends on whether Sequenced Strobing is enabled.

- When Sequenced Strobing is Disabled, all four Strobe Registers on the counter operate independently and have separate Strobe Inputs.
- When Sequenced Strobing is Enabled, all four strobes are individually triggered by Strobe Input 1.

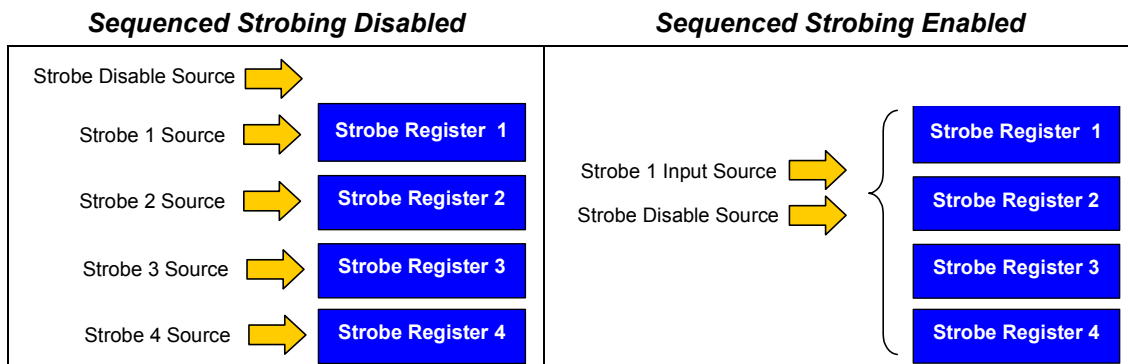

Sequenced Strobing for the User-Defined Counter

In Sequenced Strobing, when the Strobe Input 1 source is triggered, the current Accumulator value is stored in the first Strobe Register in the sequence of four registers that has a Clear Strobe status flag. Initially, this is Strobe Register 1. For example, here the Count value 100 is copied into Strobe Register 1:

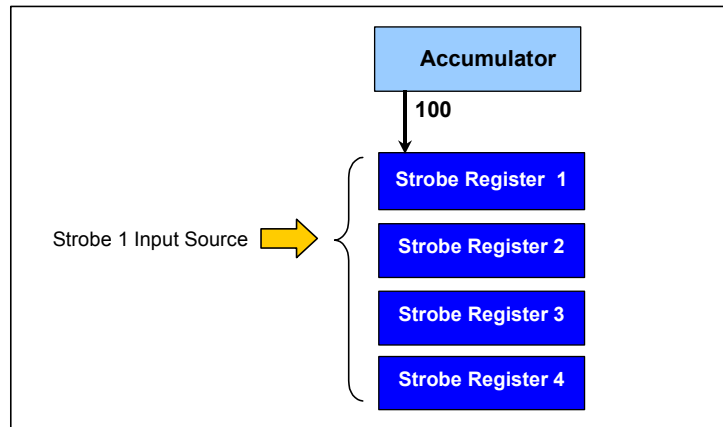

The application program reads the values in the Strobe Registers from the counter's input data.

Before new data can be stored in a Strobe Register, its Strobe Status input bit must be cleared in one of the following ways:

- A. by setting the corresponding Strobe Acknowledge bit from the application program (configured with Sequenced Strobing set to *Enabled*).
- B. by triggering one of the Preload Inputs, which clears all four strobe bits (must be configured with Sequenced Strobing set to *Enabled – Preloads or Clear Acknowledge Strobe Status Flags*).
- C. by triggering the Clear Input, which clears all four Strobe bits and sets the Accumulator to the starting value (must be configured with Sequenced Strobing set to *Enabled – Preloads or Clear Acknowledge Strobe Status Flags*).

When subsequent strobos occur, the current Accumulator value is stored to the next available Strobe Register in the sequence. For example, here the Count value 900 is copied into the next available Strobe Register, which is Strobe Register 2. If all of the Strobe Status bits are set, no additional stores are possible until one or more Strobe bits are cleared.

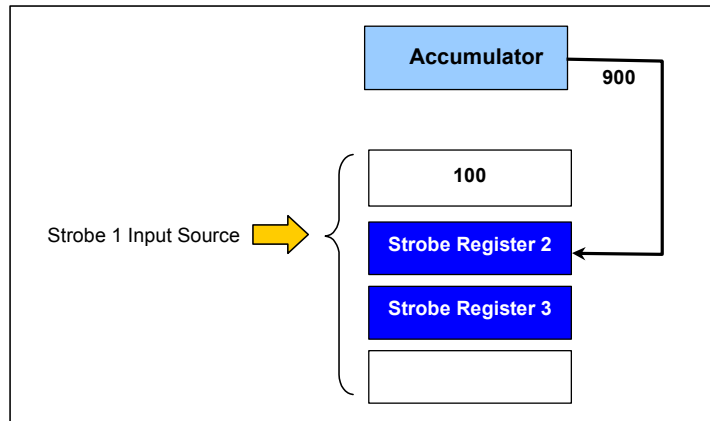

Count Down to Zero Pulse Mode for the User-Defined Counter

The User-Defined Counter Type is the only counter type other than Type E that provides a Count Down to Zero Pulse feature.

When Count Down to Zero Pulse is set to Enabled on Setpoint #4, the User-Defined Counter will turn ON Setpoint #4 when the Accumulator counts from 1 to 0. Counting does not need to begin at a Preload value. When the count value in the Accumulator counts from 1 to 0, Setpoint 4 turns On. Setpoint 4 turns Off on the next count that does not count down from 1 to 0. However, the output does not turn On if the counter counts or wraps up to 0, is preloaded to 0, or is cleared. The output pulse can be used for any purpose, for example to turn on an output point or as a Source on the sources tab. The output remains on only until the next count is recognized. Because this pulse can be very short, when used as a Source it should be set up as edge-triggered.

Chapter *Configuration*

5

This chapter describes the configurable parameters of PACSystems RX3i High-speed Counter modules.

- Configuration Basics
- High-speed Counter Module Settings
 - I/O and Diagnostic Settings
 - General Settings
- Configuring the Module's Inputs
- Configuring the Module's Outputs
- Configuring the Counters
 - Selecting the Counter Type
 - Counter Parameter Definitions
- Configuring the Counter Sources

Configuration Basics

After adding an RX3i High-Speed Counter to the rack in Machine Edition, module and counter parameters can be configured on the Settings, Inputs, Outputs, Counter Configuration, and Counter Sources tabs. As shown below, each counter has both a Configuration tab and a Sources tab.

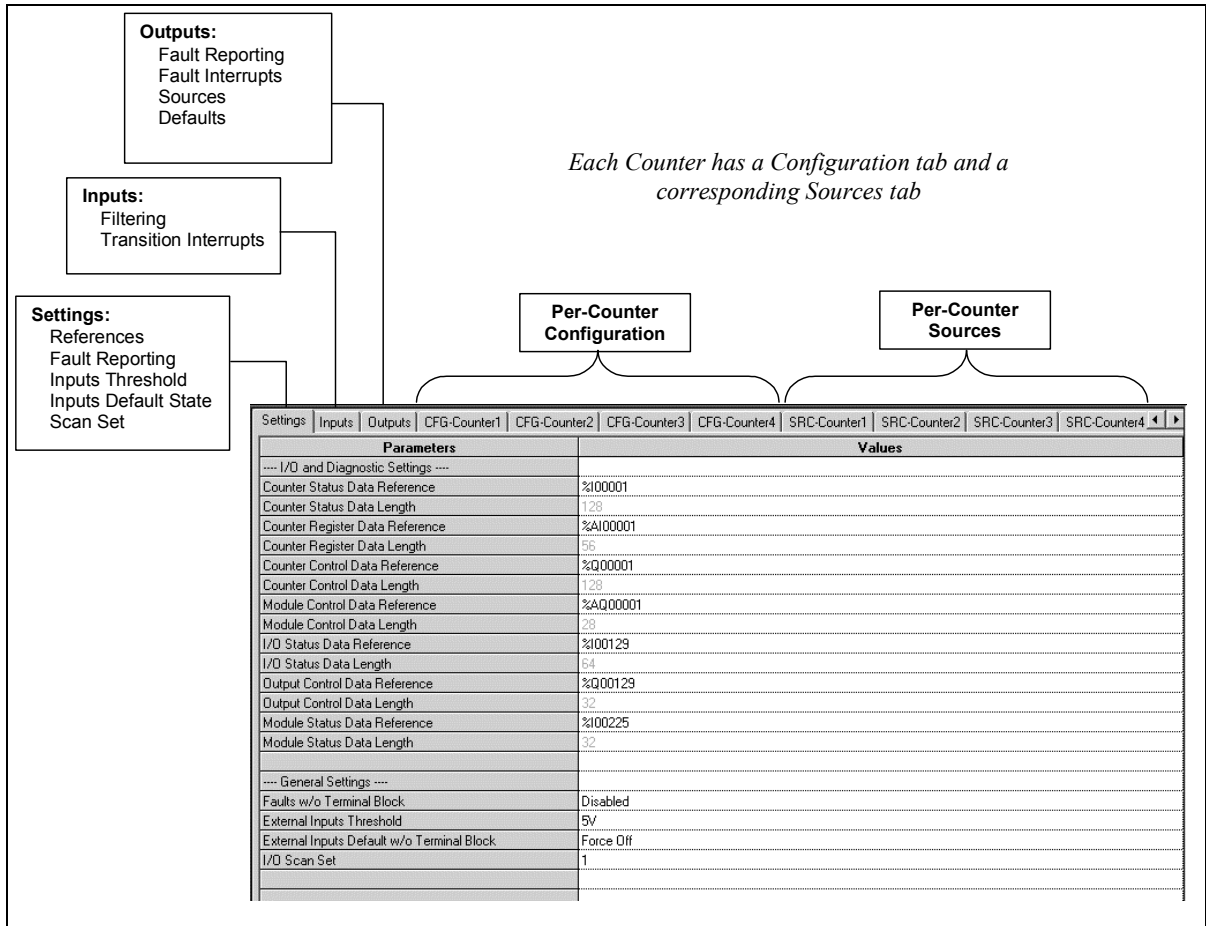

The rest of this chapter details module and counter configuration.

High-Speed Counter Module Settings

Basic module configuration includes assigning references to the module's process, status, and control data. Starting memory addresses can be automatically assigned, like the example addresses for an IC695HSC304 module shown below, or changed as appropriate.

Additional general settings determine how the module responds to faults, establish the input voltage threshold, and assign the module to a CPU Scan Set.

Settings Inputs Outputs CFG-Counter1 CFG-Counter2 CFG-Counter3 CFG-Cou	
Parameters	Values
--- I/O and Diagnostic Settings ---	
Counter Status Data Reference	%I00001
Counter Status Data Length	128
Counter Register Data Reference	%AI00001
Counter Register Data Length	56
Counter Control Data Reference	%Q00001
Counter Control Data Length	128
Module Control Data Reference	%AQ00001
Module Control Data Length	28
I/O Status Data Reference	%I00129
I/O Status Data Length	64
Output Control Data Reference	%Q00129
Output Control Data Length	32
Module Status Data Reference	%I00225
Module Status Data Length	32
--- General Settings ---	
Faults w/o Terminal Block	Disabled
External Inputs Threshold	5V
External Inputs Default w/o Terminal Block	Force Off
I/O Scan Set	1

I/O and Diagnostic Settings

The I/O and Diagnostic Settings are CPU reference addresses for external input and output data, and for the module's status and control data. The configuration software automatically assigns the next available references to each data area. These reference assignments can be used or changed for the application. The lengths of the memory areas are fixed. Chapter 5 shows how specific module data is mapped into these CPU memory areas during system operation.

Counter Status Data Reference and Length: the area of CPU memory that will be used for the module's counter status data. For module IC695HSC304, the length of this area is 128 bits. For module IC695HSC308, the length of this area is 256 bits.

Counter Register Data Reference and Length: the area of CPU memory that will be used for the module's counter registers. For module IC695HSC304, the length of this area is 56 words. For module IC695HSC308, the length of this area is 112 words.

Counter Control Data Reference and Length: the area of memory for %Q, %M, or %T data that the CPU will use to control the counters. For module IC695HSC304, the length of this area is 128 bits. For module IC695HSC308, the length of this area is 256 bits. Note that if retentive memory (%Q or %M may optionally be set up to be retentive, %T is non-retentive) is used for a control data area. This data is always retentive, so when a power cycle with battery or hot swap occurs, the control data remains in memory and is executed by the module on the next PLC output scan or output DOIO unless that data is cleared by application logic.

Module Control Data Reference and Length: the 28-word area of %AQ, %R, or %W memory for data that the CPU can use to control the module.

I/O Status Data Input Reference and Length: the 64-bit area of memory that will be used for the module's I/O Status input data.

Output Control Data Reference and Length: the 32-bit area of %Q, %M, or %T memory for data that the CPU will use to control outputs. See "Counter Control Data" above for information about retentiveness.

Module Status Data Reference and Length: the 32-bit area of memory that will be used for data about the status of the module.

General Settings

The General Settings establish basic module-wide configuration features.

Faults without Terminal Block: This setting Enables or Disables the reporting of faults if the module's terminal block is removed. The default is Disabled.

External Inputs Threshold: This setting establishes the input threshold voltage: 5 volts or 12/24 volts.

External Input Default without Terminal Block: This setting determines the state the module inputs will be set to when the module's terminal block is removed. The default is to force all inputs to Off. If Hold Last State is selected, the module will hold all inputs in their last valid states if the terminal block is not installed or is not fully latched into place.

I/O Scan Set: Defaults to 1. The module can be configured for any scan set.

Configuring the Module's Inputs

PACSystems RX3i High-speed Counter module IC695HSC304 (configuration screen below) has 8 external inputs. Module IC695HSC308 has 16 external inputs. The filtering and optional interrupt characteristics of each input can be configured on this screen.

Assigning the function of these inputs as count, strobe, preload, disable, or home inputs is done during counter configuration, on the individual SRC-Counter tabs. PACSystems RX3i High-Speed Counter modules allow the same external inputs to be used as sources for multiple counters. For example, the rising edge of Input 2 could be used as one Counter Source and its falling edge could be used as another Counter Source, not necessarily on the same counter.

Settings	Inputs	Outputs	CFG-Counter1	CFG-Counter2	CFG-Counter3	CFG-Counter4	SRC-Counter1	SRC-Cour
Input		Filtering	Transition Interrupt	Transition Interrupt Trigger Edge				
Input 1		5MHz	Disable	Rising Edge				
Input 2		5MHz	Disable	Rising Edge				
Input 3		5MHz	Disable	Rising Edge				
Input 4		5MHz	Disable	Rising Edge				
Input 5		5MHz	Disable	Rising Edge				
Input 6		5MHz	Disable	Rising Edge				
Input 7		5MHz	Disable	Rising Edge				
Input 8		5MHz	Disable	Rising Edge				

Filtering: By default, each external input is set up to use a 5MHz filter. The filter time can be changed to: 30Hz, 5KHz, 50KHz, or 500KHz. Using a lower-frequency filter can reduce the effects of signal noise. Filtering delays input transitions for approximately the selected filtering time. For example, if 5KHz filtering is selected, an input transition will not be recognized by the module until the transition has been stable for at least 200uS). **Transition Interrupt:** Each input can be Enabled to generate an interrupt upon transition. The default is Disable. See chapter 6 for information about using interrupts.

Transition Interrupt Trigger Edge: By default, each input that has its Transition Interrupt parameter Enabled will trigger a transition interrupt on its rising edge. This can be changed to either Falling Edge or Both Edges. This parameter only determines which edge of an input will trigger an optional *interrupt*. It is unrelated to how the same input operates if it is configured as a Counter source.

Configuring the Module's Outputs

PACSystems RX3i High-speed Counter module IC695HSC304 (configuration screen below) has 7 external outputs. Module IC695HSC308 has 14 external outputs. The basic operating parameters for each output are configured on this screen.

Additional parameters are set up as part of counter configuration. For example, if the Output Source for Output 2 is chosen as Setpoints on this tab, Output 2 could subsequently be configured as a Setpoint Output for Counter 1 and assigned Setpoint Limits for Counter 1.

Settings	Inputs	Outputs	CFG-Counter1	CFG-Counter2	CFG-Counter3	CFG-Counter4	SRC-Counter1	SRC-Counter2	SF ◀ ▶
Output	Circuit Fault Reporting	Circuit Fault Interrupt	Output Source	Output Default Setting					
Output 1	Disable	Disable	Setpoint(s)	Force Off					
Output 2	Disable	Disable	Setpoint(s)	Force Off					
Output 3	Disable	Disable	Setpoint(s)	Force Off					
Output 4	Disable	Disable	Setpoint(s)	Force Off					
Output 5	Disable	Disable	Setpoint(s)	Force Off					
Output 6	Disable	Disable	Setpoint(s)	Force Off					
Output 7	Disable	Disable	Setpoint(s)	Force Off					

Circuit Fault Reporting: Each output can be Enabled to generate a fault log to the I/O Fault Table if a circuit fault occurs. The default is Disabled. Circuit faults include short-circuit and open-circuit detection. The output must drive at least a 150mA load to detect open-circuit faults.

Circuit Fault Interrupt: Each output can be Enabled to generate an interrupt if a circuit fault occurs. The default is Disabled.

Output Source: The source of each output can be set as Setpoints (the default), Control Data Reference or Disabled. If the output should be controlled by one or more pairs of Setpoint On/Off values on one or more of the counter, select Setpoints. Setpoint On/Off values are set up as part of the individual counter configuration.

If the application program should directly control the output's state through the module's output references, this parameter should be set to Control Data Reference. See chapter 6 for more information about Counter Control Data.

Output Default Setting: The configured Output Default takes effect if communication with the CPU stops or if the CPU is in Output-Disabled (includes Stop-Disabled and Run-Disabled) mode and backplane power remains. If backplane power is lost, all outputs are forced off. This parameter has the following choices:

- Force Off: the output point is forced off.
- Force On: the output point is forced on.
- Hold Last State: the output point holds its last state.
- Continue Operation: the output point continues to operate with the counter Accumulator and Setpoint values. This choice is only available if the Output source has been set to Setpoints.

During powerup and initial configuration, all outputs are forced off. Outputs remain forced off until the first transition into an Outputs Enabled mode (either Run-Enabled or Stop-Enabled).

Configuring the Counters

Module IC695HSC304 has four internal counters and module IC695HSC308HSC has eight internal counters. These internal counters can be configured to operate as multiple counter types with many selectable parameters. Sources for each counter are subsequently configured on each counter's SRC-Counter tab.

Counter General Settings

Counter Type: The module can be configured for a combination of Type A, Type B, Type C, Type D, Type E, Type Z, and User-Defined Counters.

Settings		Inputs	Outputs	CFG-Counter1	CFG-Counter2	CFG-Counter3	CF
Parameters	Values						
--- General Settings ---							
Counter Type	User Defined						
Available Clock Inputs	2						
Counter Clock Type	Input 1 - Clock / Input 2 - Direction						
Timebase Units	1ms						
Timebase	1000						
Pre-scale (Divider)	1						
Count Down to Zero P...	Disabled						
Strobe Overwrite	With Acknowledge						
Sequenced Strobing	Disabled						
Homing Feature	Disabled						

Counter Types are described in detail in chapter 4. Except for the Type E Counter, all of the Counter Types use one of the module's internal counters. A Type E counter uses two internal counters. For example, an HSC304 module, which has four internal counters, might be configured for one Type A, one Type B, one Type C, and one Type D Counter. Alternatively, the same module might be configured for one Type Z, one User-Defined and one Type E Counter. Type E Counters can only be configured on odd-numbered counter tabs (Counter 1, 3, 5, or 7).

The choice made for Counter Type determines which additional features can then be configured. Only features that are appropriate for a counter type can be selected.

If a counter's Counter Type is changed after its Counter parameters and Sources have been entered, those entries are retained for the new Counter Type. So it is possible to configure a standard Counter Type, then change the Counter Type to User-Defined Counter and assign additional features.

Available Clock Inputs: The number of Clock Inputs that will update the Counter Accumulator. Counter Type A has one Counter Clock Input. Counter Types, B, D, E, and Z each have two Counter Clock inputs. The operation of the two inputs is defined by the Counter Clock Type parameter, as described below. (The selection of which inputs to use as the Counter Clock Inputs is made on the counter's Sources tab).

A Type C Counter requires four Counter Clock Inputs. The first pair increments the Counter Accumulator and the second pair decrements the Accumulator. Operation of the two input pairs is defined by the Counter Clock Type and the Second Counter Clock Type parameters.

By default, a User-Defined Counter Type has two Counter Clock Inputs, but it can be configured to have four. They operate as described for the Type C Counter.

Count Direction (Type A only): A Type A Counter can be configured to increment (Up) or decrement (Down) its Accumulator on a Count Pulse input transition. It defaults to Up.

Counter Clock Type: Determines the association between Clock Inputs 1 and 2. See chapter 3 for details. Each *pair* of clock inputs can be associated in three ways:

- Up/Down mode
- Pulse/Direction mode
- A Quad B mode

Second Counter Clock Type (Type C or User-Defined Only): Determines the association between Clock inputs 3 and 4 on a Type C Counter. See chapter 3 for information about differential counting.

Timebase Units: The units in which the configured Timebase parameter (below) will be measured. It defaults to 1ms, and can be changed to 1us or 100ns.

Examples: To set the Timebase value to 1 microsecond, set the Timebase Units value to 1us, and set the Timebase value to 1. To set the Timebase value to 10 seconds, set the timebase Units to 1ms, and set the Timebase value to 10000.

Timebase: A Timebase from 100ns to 429496 milliseconds can be selected for each counter. Timebase is the number of timebase units the module will use to count the number of pulses per timebase or the width of pulses. The Timebase defaults to 1000ms. The timebase used should not allow more counts in a timebase period than the 32-bit Counts per Timebase register can hold, otherwise it will overflow.

Pre-scale (Divider): For all Counter types, this defaults to 1. It can be changed to any value in the range 1-65535. Based on this setting, the module will scale down incoming counts so that a large number of counts will produce a smaller change in Accumulator value. The value of the pre-scale is number of counts required to increment or decrement the Accumulator by 1. For example, if the pre-scale value is 10, the Accumulator will increment or decrement once for every 10 counts. The scaled count value will have a greater range of motion, but proportionately less accuracy.

Pre-scaling the Internal Oscillator Pulse

When using the module's 2MHz internal oscillator as a counter source, a Pre-scale Divider can scale the oscillator pulse rate to a smaller value. For example, configuring a Pre-Scale Divider of 20,000 would produce a pulse rate of 100 Hertz.

Count Down to Zero Pulse: For most Counter Types, this parameter is Disabled. For a Type E Counter, Count Down to Zero Pulse mode is fixed at Enabled on Setpoint #4. For a User-Defined Counter, Count Down to Zero Pulse mode is configurable as either Disabled, or Enabled on Setpoint #4 .

In Count Down to Zero Pulse mode, the Setpoint #4 On and Off values are fixed at 0. These values are informational only. During operation, when the Accumulator value decrements to zero, an output pulse will be generated on Setpoint #4. However, no output pulse will occur when the counter wraps up to 0, is preloaded to 0, or is cleared. This pulse can be used for any purpose, for example to turn on an output point or as a Source on the sources tab. Because this pulse can be very short, when used as a source it should be set up as edge-triggered. The setpoint output remains active until the counter detects another count that does not count down from 1 to 0.

Strobe Overwrite: This defaults to With Acknowledge. With this choice, if the strobe status bit is set, it must be acknowledged by the application program before the corresponding strobe value can be overwritten. If this parameter is changed to Without Acknowledge, the strobe value can be overwritten regardless of the strobe status bit state. For a Type Z Counter, the Strobe Overwrite is applied to Clock Input Z, which performs a strobe function.

Sequenced Strobing: For a Type E or User-Defined Counter only. Sequenced Strobing can be set to Disabled, Enabled, or Enabled – Preloads or Clear Acknowledge Strobe Status Flags. Sequenced Strobing links four strobes on one counter so that they are all triggered by Strobe Input 1. When the Strobe 1 Input is triggered, the current Accumulator value is stored in the first available Strobe Register that has a Clear Strobe Status flag.

When Sequenced Strobing is Disabled, a Type E Counter has only one Strobe Register. A User-Defined Counter, will have four Strobe Registers with independent Strobe Inputs.

When Sequenced Strobing is Enabled, each Strobe flag must be cleared individually using the corresponding Strobe Acknowledge flag.

When Enabled - Preloads or Clear Acknowledge Strobe Status Flags mode is configured, Strobe bits can be cleared in one of three ways:

- A. individually using the corresponding Strobe Acknowledge bit,
- B. by triggering one of the Preloads, or
- C. by triggering the Clear, which will clear all four Strobe bits and preload the Accumulator value to 0.

Homing Feature: For a Type C or Type D Counter, Homing is fixed at Enabled. For a User-Defined Counter, Homing defaults to Disabled, but it can be Enabled. For all other counter types, the Homing Feature is Disabled.

When the Homing Feature is Enabled, a Home Position Value can be entered (in the Preload Settings section). During operation, the application can send a Home command to the module and set the counter to the configured Home Position Value.

Setpoint Limits

Each counter can be configured to have four Setpoint ON values and four Setpoint OFF Values. Setpoints are Accumulator values at which the counter's associated Setpoint Outputs will go ON and OFF. For details of Setpoint operation, please refer to chapter 3.

Setpoints may be located anywhere within the count limits.

---- Setpoint Limits ----	
Setpoint #1 (ON)	0
Setpoint #1 (OFF)	0
Setpoint #2 (ON)	0
Setpoint #2 (OFF)	0
Setpoint #3 (ON)	0
Setpoint #3 (OFF)	0
Setpoint #4 (ON)	0
Setpoint #4 (OFF)	0
---- Setpoint Outputs ----	
Setpoint #1	None
Setpoint #2	None
Setpoint #3	None
Setpoint #4	None
.Choice List: None, Output #1, Output #2, Output #3, Output #4, Output #5, Output #6, Output #7	

Setpoint #1-4 (ON): The value at which the associated Setpoint goes On. For a Type E Counter or User-Defined Counter with Count Down to Zero Pulse Enabled on Setpoint #4, ON Setpoint Limit 4 is *fixed* at 0.

Setpoint #1-4 (OFF): The value at which the associated Setpoint goes Off. For a Type E Counter or User-Defined Counter with Count Down to Zero Pulse Enabled on Setpoint #4, OFF Setpoint Limit 4 is *fixed* at 0.

Setpoint Outputs

Setpoint #1-4: This selection assigns one of the module’s external outputs to the counter’s Setpoint 1 – 4 outputs. For all Counter types, each Setpoint defaults to None. It can be changed to any of the module’s outputs. To use these setpoint values, the output must have been configured on the Outputs tab with its Output Source set to Setpoint(s).

Multiple Setpoint Outputs can be mapped to the same external output point. The signals from each Setpoint Output are logically ORed on the external output. This provides a way to create complex output pulse trains and camming patterns. Any or all Setpoint Outputs can be ORed together.

Preload Settings

For each counter, starting, or Preload, values can be set up for use when the corresponding Preload Input is activated. The Counter Types provide different Preload Value options.

Counter Type	Configurable Preload Values
A	Preload 1
B	Preload 1
C	Preload 1, 2, Home Position
D	Home Position
E	Preload 1, Preload 2 (upper Accumulator value for counting down)
Z	Preload 1
User-Defined	Preload 1, 2, 3, 4, Home Position (Home Position replaces Preload 4 when Homing is enabled.)

For example, the Preload Settings parameters for a Type C Counter are shown below.

--- Preload Settings ---	
Preload 1 Value	0
Preload 2 Value	0
Home Position Value	0

If Count Mode (see below) will be configured for either Continuous within High/Low Range, or One-Shot within High/Low Range, the Preload Value(s) selected here must lie within the configured range limits.

If Count Mode will be configured for either Continuous Beyond High/Low Range, or One-Shot Beyond High/Low Range, the Preload may lie beyond the configured range limits.

A Type E counter has two configurable Preload Settings. Preload 1 operates like a normal preload. Preload 2 is the automatic preload that is loaded when a Type E counter counts down to 0 in continuous mode. Preload 2 is also the starting accumulator value in either continuous or one-shot mode.

Home Position Value: The value to which the Accumulator will be set during a homing operation. This parameter is only available for a Type C, Type D, or User-Defined Counter when the Homing feature is enabled. It defaults to 0.

Range and Limit Settings

The Range and Limit Settings establish Under Range and Over Range values for the counter, and also determine how counting will be affected by those values.

--- Range and Limit Set...	
Count Mode	Continuous within high/low range
Low Range	-2147483648
High Range	2147483647
Rate of Change	0

Count Mode: This defaults to Continuous within over/under range. See chapter 3 for details of Count Mode operation. The configuration choices are:

- In Continuous within High/Low Range mode, a counter counts continuously within its range. If either the High Range or the Low Range value is exceeded, the counter wraps around to the other limit and continues counting.
- In One-Shot within High/Low Range mode, the counter count to its configured High Range or Low Range value then stops, and subsequent counts in that direction are lost. When a One-shot within Range counter is at the High Range or Low Range limit, the direction can be reversed and the counter will back away from the limit.
- In Continuous Beyond High/Low Range mode, a counter continues counting even if the High Range or Low Range limit is exceeded. Counting continues to the Underflow or Overflow limit, then wraps around. Fault Reporting can be enabled so the application program can check for High Range and Low Range conditions and respond.
- In One-Shot Beyond High/Low Range mode, the counter may increment the Accumulator past the configured range limits. The count will stop at the Underflow/Overflow limit. If an UP count is received at the Overflow limit, the Accumulator stays at this value (but sets the Overflow flag). If a DOWN count is received at the Underflow limit, the Accumulator stays at this value (but sets the Underflow flag). Fault Reporting can be enabled so the application program can respond to beyond range conditions.

Count Mode for a Type E Counter: When a Type E counter operates in continuous counting mode, the counter automatically reloads itself with the configured Preload 2 value when it reaches zero, and continues counting down.

When a Type E counter operates in one-shot mode, the counter stops when it decrements to zero. Counting is enabled again when the counter is Preloaded with Preload 1.

Under Range and Over Range: Each Counter Type has a default Low Range and High Range limit.

	Default Low Range Limit	Default High Range Limit
Type A Counter	-32768	32767
Type B, C, D, Z or User-Defined Counter	-2147483648	2147483647
Type E Counter	0	65535

These values are the lower and upper boundaries of its normal operating range. For all counter types, they can be changed to 32-bit values. Both range values can be positive or negative, but the High Range value must always be greater than the Low Range value.

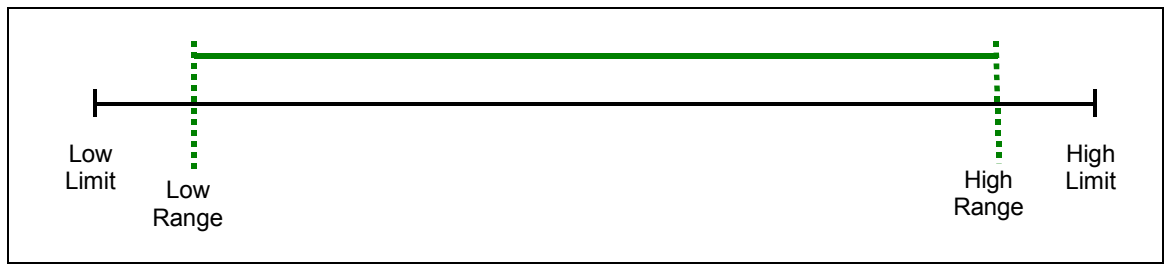

The application program can use the Counter Status data to monitor the counter for operation within its intended range. Range Values also set the boundaries for counting when either Continuous or One-Shot within Range is selected, as explained above.

Rate of Change: For all Counter types, this defaults to 0, which disables Rate of Change detection. Configuring Rate of Change to a positive or negative value enables Rate of Change detection. During operation, the module will compare the current value in the counter's Counts per Timebase Register against its configured Rate of Change.

- Enter a positive value if the counter should set the Rate of Change status bit if the Rate of Change exceeds the specified value in the positive or “up” direction.
- Enter a negative value if the counter should set the Rate of Change status bit if the Rate of Change exceeds the specified value in the negative or “down” direction.

If Interrupts are Enabled, a Rate of Change interrupt can also be enabled separately.

Special Output Settings

Special Output Settings parameters are configured for Type E Counters only.

--- Special Output Setti...	
<i>Response Output Mode</i>	Pulse Mode
Outpulse Milliseconds	10
Response Output Point	None <input type="text" value="Choice List: Pulse Mode, Latch Mode"/>

Response Output Mode: In Pulse mode (the default), the Response Output Point (below) turns on when the counter decrements to zero, and stays on for the duration configured by the Outpulse Milliseconds parameter.

In Latch mode, the Response Output Point remains on until the counter is preloaded with Preload 1. Latch mode is not available if the Count Mode is either Continuous Within High/Low Range, or Continuous Beyond High/Low Range.

Outpulse Milliseconds: In Pulse mode, the length of time in milliseconds the Response Output Point will stay on. It defaults to 10. Note: When the Count mode is configured for continuous counting and the Response Output Mode is configured for Pulse Mode, the configured pulse duration must be less than the time required to count from the preload down to zero. This ensures that the output has had time to turn off before being set again.

Response Output Point: This parameter defaults to None. It can be changed to any of the module's output points. The output point must also have its source set to Setpoint(s) on the Outputs tab.

Event Reporting Settings

Event Reporting Settings parameters are the same for all Counter types. They default to Disable.

--- Event Reporting Settings ---	
Fault Enable	Disable
<i>Interrupt Enable</i>	Disable

Fault Enable: This parameter determines whether or not the following faults would be logged in the I/O Fault Table for the counter: Rate of Change Alarm, Under Range Alarm, Over Range Alarm, Underflow Alarm, Overflow Alarm, Encoder Fault.

Interrupt Enable: If Interrupts Enable is set to Enabled, specific interrupt types can then be individually enabled, as shown below. By default all interrupt types are Disabled. If any interrupts are set to Enabled, an Interrupt block must be defined for the module. During operation, if an interrupt condition occurs, the CPU suspends its current activity, updates the appropriate input data, then executes the interrupt logic. See chapter 7 for information about using Interrupts.

--- Event Reporting Settings ---	
Fault Enable	Disable
<i>Interrupt Enable</i>	Enable
Over Range Interrupt Enable	Disable
Under Range Interrupt Enable	Disable
Encoder Fault Interrupt Enable	Disable
Overflow Interrupt Enable	Disable
Underflow Interrupt Enable	Disable
Rate Of Change Interrupt Enable	Disable
Setpoint #1 (ON) Interrupt Enable	Disable
Setpoint #1 (OFF) Interrupt Enable	Disable
Setpoint #2 (ON) Interrupt Enable	Disable
Setpoint #2 (OFF) Interrupt Enable	Disable
Setpoint #3 (ON) Interrupt Enable	Disable
Setpoint #3 (OFF) Interrupt Enable	Disable
Setpoint #4 (ON) Interrupt Enable	Disable
Setpoint #4 (OFF) Interrupt Enable	Disable

Configuring the Counter Sources

The sources for each counter are configured on a set of tabs corresponding to the set of Counter tabs. For example, the sources for Counter 2 are configured on the SRC-Counter 2 tab.

The number and type of sources that can be configured depend on the counter type that has been selected, and on some of the entries made on the Counter tabs. For example, the initial counter sources screen for a Type B Counter is shown below.

Parameters		Values
---- Source Settings ----		
Clock Input 1	Source	None
Clock Input 2	Source	None
Counter Disable	Source	None
Strobe 1	Source	None
Strobe 2	Source	None
Preload 1	Source	None

Counter Source Definitions

Clock Input (1, 2, 3, 4): The number of Clock inputs available depends on the Counter Type being configured. For a User-Defined Counter, the number of inputs also depends on the selection made for Counter Clock Inputs on the Counter tab:

- Type A Counter: 1 Clock input
- Type B, Type D, Type E, Type Z Counter: 2 Clock inputs
- Type C Counter: 4 Clock inputs
- User-defined Counter: 1, 2, or 4 Clock inputs

The Clock Input 1, 2, 3, and 4 Sources can be selected from the following types, depending on the configured Counter Type and Counter Clock Type.

Input Source	Up* or Up / Down Clock Type		Clock / Direction Clock Type		A Quad B Clock Type	
	Up Input	Down Input	Clock Input	Direction Input	A Input	B Input
None	1, 3	2, 4	1, 3	2, 4	1, 3	2, 4
Internal Oscillator (2MHz)**	1, 3	2, 4	1, 3			
External Input: the state of any of the module's external input points	1, 3	2, 4	1, 3	2, 4	1, 3	2, 4
External Output: the state of any of the module's external output points.	1, 3	2, 4	1, 3	2, 4	1, 3	2, 4
Counter Pulse (Count): the count of any of the module's other counters.	1, 3	2, 4	1, 3			
Always 0: used to set direction only.				2, 4		
Always 1: used to set direction only.				2, 4		
Control Data Reference: used to set direction only.				2, 4		

* Type A Counter has only 1 input and is an Up Counter only. (This is also true for a User-Defined Counter with 1 clock input).

** On a counter with four clock inputs (Type C or user-Defined), the Internal Oscillator cannot be used as the input source for corresponding inputs (for example, input 1 and input 3).

Each source can then be configured for either Rising Edge or Falling Edge.

Clock Input Z (for a Type Z Counter)

The Clock Z Input is a special input that is available only on the Type Z Counter. It can be used to trigger a store of the current Accumulator value to the counter's Strobe 1 memory. See the description of the Type Z Counter in chapter 4 for more information.

Z Input Mode Setting: For a Type Z Counter, Clock Input Z input can be used to trigger a store of the current Accumulator value to the counter's Strobe #1 memory. Both the source

and the polarity of the Clock Input Z are configurable. The stored count value is retained in memory until another store occurs.

In *Store/Continue* mode, Clock Input Z triggers a store and the counter continues counting.

In *Store/Wait/Resume* mode, Clock Input Z triggers a store, but counting stops for as long as the selected Clock Input Z source remains in the configured Polarity.

In *Store-Reset/Wait/Start* mode, Clock Input Z triggers a store and resets the counter to zero. The counter stops counting for as long as the selected Clock Input Z source remains in its configured Polarity.

In *Store-Reset/Start* mode, Clock Input Z triggers a store and resets the counter to zero, The counter immediately resumes counting.

Clock Input Z Sources

For Clock Input Z, the triggering input can be any of the following sources. Each source type can then be configured to respond to either Rising Edge / High Level or Falling Edge / Low Level.

Clock Input	Source	Description
Z	None	Function disabled
	External Input	Any one of the module's external inputs.
	External Output	Any one of the module's external outputs.
	Setpoint Output State	Any counter and setpoint number. Can be set for on to off or off to on transition of the setpoint state.
	Overflow Trigger *	Any counter's Accumulator over its high (maximum) level.
	Underflow Trigger *	Any counter's Accumulator under its low (minimum) level.
	Overrange Trigger	Any counter's Accumulator at its configured Over Range value.
	Underrange Trigger	Any counter's Accumulator at its configured Under Range value.
	Counter Pulse (Count) *	The count of one of the module's other counters.

- * These sources do not produce an input signal that stays high or low for a significant period of time, so if the Z input is in a wait mode, it may never stop receiving counts for these sources. It properly stores or resets the values as expected.

Counter Disable: For a Type B, C, E or User-Defined Counter, the Counter Disable input inhibits counting when active. All Counter Disable Sources are level-sensitive.

Source	Description
None	Function disabled
External Input	Any one of the module's external inputs.
External Output	Any one of the module's external outputs.
Setpoint Output State	Any counter's Setpoint Output.
HighRange Trigger	Any counter's Accumulator counting beyond its configured High Range value.
Low Range Trigger	Any counter's Accumulator counting beyond its configured Low Range value.
Assign to Control Data Reference	Command from application program by setting a program reference. Counter Disable bit in Counter Control Data Reference.

Strobe (1, 2, 3, 4): The number of Strobe sources depends on the counter type:

- Type A or Type E Counter: 1 Strobe source
- Type B Counter: 2 Strobe sources
- Type C Counter: 3 Strobe sources
- User-defined Counter: 4 Strobe sources
- Type D: None

Each Strobe Source can be any of the following. Strobe sources can be configured to respond to either Rising Edge, Falling Edge, or Both Edges.

Source	Description
None	Function disabled
External Input	Any one of the module's external inputs.
External Output	Any one of the module's external outputs.
Setpoint Output State	Any counter's Setpoint Output.
Overflow Trigger	Any counter's Accumulator over its high (maximum) limit.
Underflow Trigger	Any counter's Accumulator under its low (minimum) limit.
High Range Trigger	Any counter's Accumulator counting beyond its configured High Range value.
Low Range Trigger	Any counter's Accumulator counting beyond its configured Low Range value.
Counter Pulse (Count)	The count of one of the module's other counters.
Assign to Control Data Reference	Command from application program by setting a program reference. Counter Control Data Reference using Strobe 1 – 4 Trigger bits.

Preload (1, 2, 3, 4): The number of configurable Preload Sources depends on the counter type:

Type A, B, or Z Counter:	1 Preload Source
Type C or E Counter:	2 Preload Sources
User-defined Counter:	4 Preload Sources (3 if Homing is enabled)
Type D Counter:	None

All Preload Sources are either edge-sensitive or level-sensitive. If a level-sensitive source is used, the Accumulator stays at the configured Preload value as long as the Preload source is being triggered.

Source	Description
None	Function disabled
External Input	Any one of the module's external inputs.
External Output	Any one of the module's external outputs.
Setpoint Output State	Any counter's Setpoint Output.
Overflow Trigger	Any counter's Accumulator over its high (maximum) limit.
Underflow Trigger	Any counter's Accumulator under its low (minimum) limit.
High Range Trigger	Any counter's Accumulator counting beyond its configured High Range value.
Low Range Trigger	Any counter's Accumulator counting beyond its configured Low Range value.
Counter Pulse (Count)	The count of one of the module's other counters.
Assign to Control Data Reference	Command from application program by setting a program reference. Counter Control Data Reference using Preload 1 – 4 Trigger bits.

For a Type E counter, the source of Preload 2 is None when the counter is in one-shot mode, or "Counter N, Setpoint 4", which is the "Count Down to Zero Pulse" setpoint when the counter is in Continuous mode.

Strobe Disable: For a Type E or User-Defined Counter, a Strobe Disable input will inhibit all strobe latching of the counter accumulator into the strobe registers. One Strobe Disable input is used for all four Strobe inputs on the counter. The configurable Strobe Disable sources are the same as for Counter Disable, above. Strobe Disable sources are level-sensitive.

Preload Disable: For a User-Defined Counter, the Preload Disable input inhibits Preload operation. The configurable Preload Disable sources are the same as for Counter Disable, above. Preload Disable sources are level-sensitive.

Home Switch: Only for a Type C Counter or User-Defined Counter with Homing enabled. Home Switch sources are listed below. All Home Switch sources can be set up as edge-sensitive or level-sensitive.

Source	Description
Always On	No Home Switch used.
External Input	Any one of the module's external inputs.
External Output	Any one of the module's external outputs.
Setpoint Output State	Any counter's Setpoint Output.
Overflow Trigger	Any counter's Accumulator over its high (maximum) limit.
Underflow Trigger	Any counter's Accumulator under its low (minimum) limit.
High Range Trigger	Any counter's Accumulator counting beyond its configured HighRange value.
Low Range Trigger	Any counter's Accumulator counting beyond its configured Low Range value.
Counter Pulse (Count)	The count of one of the module's other counters.

Home Marker: Only for a Type C or D Counter, or a User-Defined Counter with Homing enabled. Home Marker Sources are either edge- or level-sensitive.

Source	Description
None	Function disabled
External Input	Any one of the module's external inputs.
External Output	Any one of the module's external outputs.
Setpoint Output State	Any counter's Setpoint Output.
Overflow Trigger	Any counter's Accumulator over its high (maximum) limit.
Underflow Trigger	Any counter's Accumulator under its low (minimum) limit.
High Range Trigger	Any counter's Accumulator counting beyond its configured High Range value.
Low Range Trigger	Any counter's Accumulator counting beyond its configured Low Range value.
Counter Pulse (Count)	The count of one of the module's other counters.

Clear: For a User-Defined Counter only, when the Clear signal is activated, the counter Accumulator is immediately and asynchronously reset to the starting value. Ordinarily, the Clear Input sets the Accumulator value to zero. If zero does not lie between the counter's configured Low Range and High Range values, the Clear Input sets the Accumulator to the configured Low Range value. See chapter 4 for more information.

All Clear sources can be set up as either edge-sensitive or level-sensitive. When configured as level-sensitive, the counter is held in its reset state while the Clear signal is at the Clear logic level. In edge-sensitive mode, the counter is reset at the active edge of the Clear signal, but is enabled for counting regardless of the logic level of the clear input.

Source	Description
None	Function disabled
External Input	Any one of the module's external inputs.
External Output	Any one of the module's external outputs.
Setpoint Output State	Any counter's Setpoint Output.
Overflow Trigger	Any counter's Accumulator over its high (maximum) limit.
Underflow Trigger	Any counter's Accumulator under its low (minimum) limit.
High Range Trigger	Any counter's Accumulator counting beyond its configured High Range value.
Low Range Trigger	Any counter's Accumulator at its configured Low Range value.
Counter Pulse (Count)	The count of one of the module's other counters.
Assign to Control Data Reference	Command from application program by setting a program reference. Counter Clear bit in Counter Control Data Reference.

Chapter *Module Data*

6

This chapter describes all of the input and output data used by a PACSystems RX3i High-speed Counter module. It also explains the sequence in which data is exchanged, and describes how the DO I/O and Suspend I/O functions can be used to control data exchange with the module.

- Module Data Types and References
- Input Data
 - Counter Register Data
 - Counter Status Data
 - I/O Status Data
 - Module Status Data
- Output Data
 - Counter Control Data
 - Module Control Data
 - Output Control Data
- Using DO I/O and Suspend I/O

Module Data Types and References

When an RX3i High-speed Counter module is configured, the CPU automatically reserves several memory areas for the module's data. The lengths of these area are fixed, as listed below. Starting reference addresses for each area are assigned by the configuration software, but can be changed as needed for the application (refer to chapter 5 for configuration details).

Data Type	Length	Memory Type	Used For
<i>Counter Status Data</i>	HSC304: 128 bits HSC308: 256 bits	%I, %M, %T, or discrete I/O variables	Counter status data
<i>Counter Register Data</i>	HSC304: 56 words HSC308: 112 words	%AI, %R, %W, or word I/O variables	Module counter registers
<i>Counter Control Data</i>	HSC304: 128 bits HSC308: 256 bits	%Q, %M, %T, or discrete I/O variables	Data sent by the CPU to control counter operation
<i>Module Control Data</i>	28 words	%AQ, %R, %W, or word I/O variables	Data sent by the CPU to control module operation
<i>I/O Status Data</i>	64 bits	%I, %M, %T, or discrete I/O variables	I/O Status input data and Output Fault Status Data
<i>Output Control Data</i>	32 bits	%Q, %M, %T, or discrete I/O variables	Data sent by the CPU to control outputs
<i>Module Status Data</i>	32 bits	%I, %M, %T, or discrete I/O variables	Data that indicates the module status

The rest of this chapter describes how each of these data types is structured, and how each can be used.

Note that if retentive memory (%Q or %M may optionally be set up to be retentive, %T is non-retentive) is used for Counter Control Data or Output Control Data, when a power cycle with battery or hot swap occurs, the control data remains in memory and is executed by the module on the next PLC output scan or output DOIO unless that data is cleared by application logic.

Input Data

The High-speed Counter module automatically provides four separate types of input data to the CPU.

<i>Data Type</i>	<i>Data Length</i>
Counter Register Data	For IC695HSC304: 56 words For IC695HSC308: 112 words
Counter Status Data	For IC695HSC304: 128 bits For IC695HSC308: 256 bits
I/O Status Data	64 bits
Module Status Data	32 bits

Each of these data types is described on the following pages.

Input Data Updates

The PACSystems RX3i CPU reads the module's input data at these times:

- before every pass through the application program (if Scan Set 1 is used, and not Suspend I/O). All four Input data types are updated in each input scan.
- before triggering a ladder interrupt, when input data related to the interrupt is refreshed.
- when a DO I/O function in the application program requests the data. Use of DO I/O is explained later in this chapter.

Counter Input Register Data

The Counter Input Register data provided to the CPU contains the current values in the module's internal counter registers. For each counter, the following data is sent:

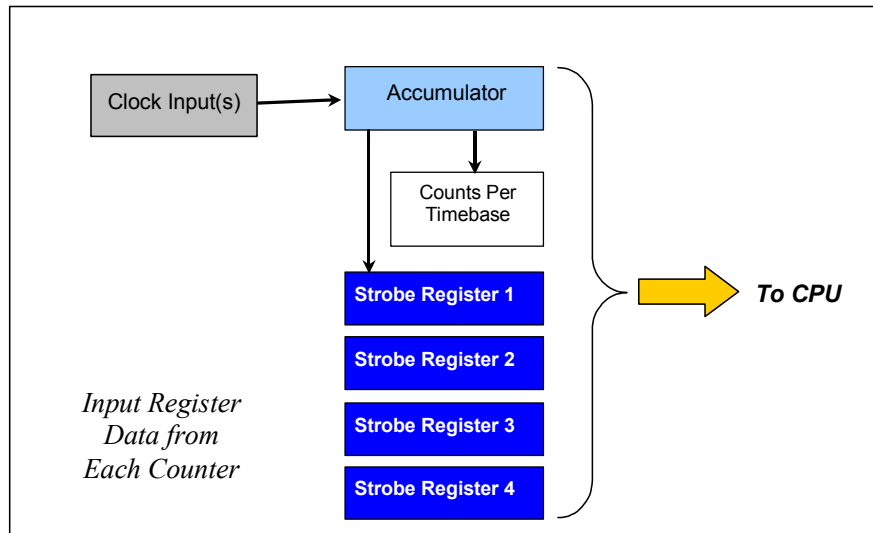

For High-speed Counter module IC695HSC304, the overall length of this data is 56 words (4 counters with 14 words per counter). For module IC695HSC308, the Counter Register Data length is 112 words (8 counters with 14 words per counter). During module configuration, this data can be assigned to any available reference in %AI, %R, or %W, memory or to I/O variables.

Counter Input Register Data Format

The Counter Register data from each counter has the format show below. Each register is 32 bits in length.

Counter Reference Address	Data
Address + 0, Address + 1	Accumulator Value
Address + 2, Address +3	Strobe 1 Register Value
Address + 4, Address +5	Strobe 2 Register Value
Address + 6, Address +7	Strobe 3 Register Value
Address + 8, Address +9	Strobe 4 Register Value
Address + 10, Address +11	Counts per Timebase Value
Address + 12, Address +13	Reserved

Depending on the configuration and Counter Type, some registers may not be used. Unused registers are set to 0 .

Counter Status Data

The Counter Status Input data is bit-type data that indicates the status of counter operations. For High-speed Counter module IC695HSC304, the overall length of this data is 128 bits (4 counters with 32 Counter Status bits per counter). For module IC695HSC308, the Counter Status Data length is 256 bits (8 counters with 32 Counter Status bits per counter). During module configuration, this data can be assigned to any available reference in %I, %M, or %T memory or I/O variables.

Counter Status Data Format for Each Counter

For each Counter, the Counter Status data has the format shown below. Unused bits are set to 0. Status bits for Preloads (and others) are set if a source triggers an event.

Counter Reference	Data	Meaning
Address +0 bits	Strobe 1 Status	0 = Strobe Has Not Occurred 1 = Strobe Has Occurred
Address +1	Strobe 2 Status	
Address +2	Strobe 3 Status	
Address +3	Strobe 4 Status	
Address +4	Preload 1 Status	0 = Preload Has Not Occurred 1 = Preload Has Occurred
Address +5	Preload 2 Status	
Address +6	Preload 3 Status	
Address +7	Preload 4 Status	
Address +8	Setpoint 1 Compare Status	0 = Setpoint Is Off 1 = Setpoint Is On
Address +9	Setpoint 2 Compare Status	
Address +10	Setpoint 3 Compare Status	
Address +11	Setpoint 4 Compare Status	
Address +12 to +14	Reserved	Always 0
Address +15	Home Found	0 = Home Not Found, 1 = Home Found
Address +16	Setpoint 1 ON Interrupt Status	0 = Setpoint Interrupt Has Not Occurred 1 = Setpoint Interrupt Has Occurred
Address +17	Setpoint 1 OFF Interrupt Status	
Address +18	Setpoint 2 ON Interrupt Status	
Address +19	Setpoint 2 OFF Interrupt Status	
Address +20	Setpoint 3 ON Interrupt Status	
Address +21	Setpoint 3 OFF Interrupt Status	
Address +22	Setpoint 4 ON Interrupt Status	
Address +23	Setpoint 4 OFF Interrupt Status	
Address +24	Rate of Change	0 = Rate of Change Limit Not Exceeded 1 = Rate of Change Limit Exceeded
Address +25	Under Range	0 = Under Range Has Not Occurred 1 = Under Range Has Occurred
Address +26	Over Range	0 = Over Range Has Not Occurred 1 = Over Range Has Occurred
Address +27	Underflow	0 = Underflow Has Not Occurred 1 = Underflow Has Occurred
Address +28	Overflow	0 = Overflow Has Not Occurred 1 = Overflow Has Occurred
Address +29	Encoder fault	0 = Encoder Fault Has Not Occurred 1 = Encoder Fault Has Occurred
Address +30 and +31	Reserved	Always 0

Counter Status Data Description

Strobe Status: Each Strobe Status bit indicates that the Accumulator count value has been copied into corresponding Strobe Register. If the Strobe Overwrite parameter is set to “With Acknowledge”, this bit should be cleared by setting the corresponding Strobe Acknowledge output bit. If the module is configured for Sequenced Strobing, additional strobes of the same register are ignored until the Strobe Acknowledge output bit is set.

Preload Status: Each Preload Status bit indicates the corresponding Preload Input has just copied its Preload Value into the counter Accumulator. If an application program uses this bit, it should be cleared by setting the corresponding Preload Acknowledge output bit.

Setpoint / Compare Status: Each bit indicates whether the a Setpoint Output is On or Off.

Home Found: This bit indicates that the Home Position Value has just been copied into the counter Accumulator. The Home Found bit is set on the rising edge of the Home Marker input if the Home Command bit is set. When the Home Command bit is cleared and then set again, the Home Found bit is also cleared.

Setpoint Interrupt Status: These bits are set when the corresponding Setpoint output has changed state and generated an interrupt. These bits can be used by an interrupt routine to determine which outputs have generated interrupts. The Setpoint Interrupt Status bits should only be tested in a ladder logic interrupt handler. These status bits are automatically cleared when read; they are only set for a single scan (or single interrupt pass)

Rate of Change*: This bit indicates whether or not a Rate of Change Limit has been exceeded. See chapter 3 for more information about Rate of Change limits.

Under Range, Over Range*: These bits are set to 1 if an underrange or overrange condition has occurred. The relationship between the Over/Under Range and Overflow/Underflow Counter Status bits depends on the configured counting mode. See below.

Underflow, Overflow*: These bits are set to 1 if an underflow or overflow has occurred:

Counter Mode	Over Range Bit	Under Range Bit	Overflow Bit	Underflow Bit
Continuous within range	Set when counter wraps from high to low range	Set when counter wraps from low to high range	Never set	Never set
Continuous beyond range	Set when counter exceeds high range	Set when counter precedes low range	Set when counter wraps from high to low limit	Set when counter wraps from low to high limit
One-shot within range	Set when up-count is received while at high range	Set when down-count is received while at low range	Never set	Never set
One-shot beyond range	Set when counter exceeds high range	Set when counter precedes low range	Set when up-count is received while at high limit	Set when down-count is received while at low limit

Encoder Fault*: this bit is set to 1 if an encoder fault or A quad B quadrature error has occurred.

* The module continues to present any occurrences of the conditions for at least one complete Input Scan cycle. That ensures that the conditions can be detected and are not missed between scans.

I/O Status Data

The I/O Status Data indicates the present states and status of the module's external I/O points. For both RX3i High-Speed Counter Modules, the length of this data is 64 bits. During module configuration, it can be assigned to any available references in %I, %M, or %T memory, or discrete I/O variables.

I/O Status Data Format

The I/O Status Data has the format shown below. Reserved bits are always 0.

<i>Reference Address</i>	<i>Data</i>	<i>Meaning</i>
Address +0 to Address + 15	<i>External Inputs</i> IC695HSC304: 8 input bits + 8 reserved IC695HSC308: 16 input bits	0 = External Input is de-asserted (low logic) 1 = External Input is asserted (high logic)
Address +16 to Address + 31	<i>External Input Interrupt Status</i> IC695HSC304: 8 input bits + 8 reserved IC695HSC308: 16 input bits	0 = External Input Interrupt Has Not Been Triggered 1 = External Input Interrupt Has Been Triggered
Address +32 to Address +47	<i>External Outputs *</i> IC695HSC304: 7 input bits + 9 reserved IC695HSC308: 14 input bits +2 reserved	0 = External Output is de-asserted (low logic) 1 = External Output is asserted (high logic)
Address +48 to Address +63	<i>Output Fault Status Data</i> IC695HSC304: 7 input bits + 9 reserved IC695HSC308: 14 input bits + 2 reserved	0 = Circuit Fault Condition Not Detected 1 = Circuit Fault Condition Detected

* The Output Status bits are set regardless of the source (Module Control data or Setpoints).

I/O Status Data Description

External Inputs: These bits indicate the present state of the module's external input points at the time I/O is serviced.

External Input Interrupt Status: If Interrupts are enabled, these bits indicate the present state of the module's input transition interrupts. These bits are only set immediately before an Input Transition I/O Interrupt logic block execution. Bits should only be checked in the I/O Interrupt logic block.

External Outputs: These bits indicate the present state of the module's output points at the time I/O is serviced.

Output Fault Status Data: These bits indicate the presence of faults on the output circuits. The module detects open circuit, short to ground, and short to V+ output faults. When an output is ON it must drive a load of at least 150mA to prevent false Open-Circuit Detected flags.

Module Status Data

The Module Status data provides the CPU with basic diagnostic information about module operation. For both RX3i High-Speed Counter modules the length of this data is 32 bits. During module configuration, it can be assigned to any available references in %I, %M, or %T memory, or to discrete I/O variables.

Module Reference Address	Data	Meaning
Address +0 bits	Module Ready	0 = Module Not Ready 1 = Module Ready
Address +1	Terminal Block Present	0 = Terminal Block Not Present 1 = Terminal Block Present
Address +2	Field Power Lost	0 = Field Power Not Lost 1 = Field Power Lost
Address +3	Reserved	Always 0
Address +4	Command Error	0 = Command Error Has Not Occurred 1 = Command Error Has Occurred
Address +5 to Address +15	Reserved	Always 0
Address +16 to Address +31	Error Description	See next page

Module Status Data Description

Module Ready: The module sets this bit when it is ready to begin servicing requests from the CPU. This bit clears to 0 if the module is not configured or not present, or has a fatal error.

Terminal Block Present: The module sets this bit if its removable Terminal Block is either not present or not fully-latched into place.

Field Power Lost: The module sets this bit if it is not receiving power from its external power source. Module IC695HSC308 requires field power and field ground to pins 17 & 33 and pins 18 & 36. Both connections must be made to clear this bit.

Command Error: The module sets this bit if it has received an incorrect command or been unable to process a command.

Error Descriptions: The module sets these bits as shown on the next page to describe the specific error that has occurred.

Module Status Data: Error Description

If the module receives an invalid command, the module sets the command error bit (see previous page) to 1. It also sets the error description bits shown below to indicate which error has occurred.

Bits 15-12 indicate whether the error occurred in Command Area 1 or 2. Command Areas are described in the output data section of this chapter.

Bits 11-8 may contain the number of the counter on which the error occurred.

Bits 7 – 0 contain an Error Code that specifies the error type.

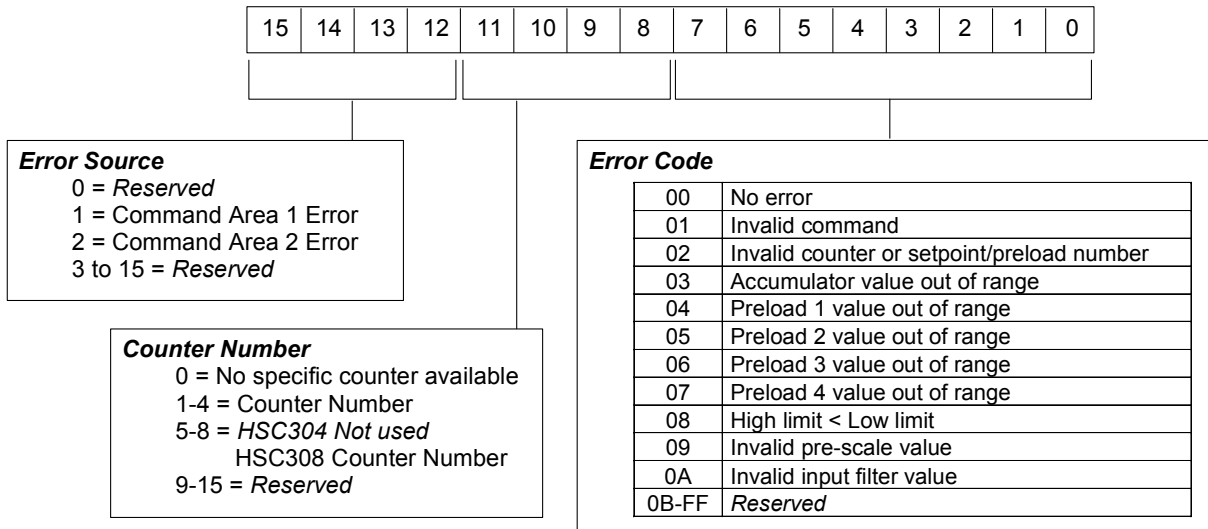

After the error condition has been corrected, the application program must acknowledge the error by setting the clear error bit in the Module Control (output) data to 1. See the section on output data for more information. The module will not log additional error codes until the error has been acknowledged by setting the clear error bit.

Fatal errors (RAM, EPROM) have no error codes because these errors cause the watchdog timer to expire and the module to go into failure mode (the Module Status LED blinks).

Output Data

The PACSystems RX3i CPU provides three separate types of output data to an RX3i High-speed Counter module. The application program can use this data to automatically send control commands to the module.

The PACSystems RX3i CPU sends the module's output data at these times:

- after every pass through the application program (if the configured Scan Set is 1 and Suspend I/O is not in use). The output data scanned is:

<i>Data Type</i>	<i>Data Type</i>
Module Control Data	28 words
Output Control Data	32 bits
Counter Control Data	For IC695HSC304: 128 bits For IC695HSC308: 256 bits

- when a DO I/O function in the application program writes the data.

RX3i High-speed Counter modules do not respond to COMMREQ (Communication Request) commands. For commands that need to be executed immediately, the application program should update the module's command output references then send a DO I/O command to the module. Use of DO I/O is explained later in this chapter.

Overview of Sending Output Data

The High-speed Counter module performs commands first (in Command Area 1 and 2), so Counter Control bits should operate on the newly-updated registers during the same sweep.

The High-speed Counter checks each command it receives for validity. If the command syntax is incorrect, the module ignores the command and responds by setting the Error Status %I bit and returning a status code describing the error in the Module Status word. The Error can be cleared by toggling the Clear Error bit.

Module Control Data

The Module Control Data contains commands to control module operation. The length of this data area is 28 words. During module configuration, this data can be assigned to any available reference in %AQ, %R, or %W memory, or to word I/O variables.

Module Control Data Format

Module Control Data has the format shown below. Reserved bits should always be 0.

<i>Module Reference Address</i>	<i>Data</i>	<i>Meaning</i>
Address +0	<i>Output Disables</i> IC695HSC304: 7 input bits + 9 reserved IC695HSC308: 14 input bits + 2 reserved	0 = Output Point is Not Disabled 1 = Output Point is Disabled
Address +1	Clear Error Flag (1 bit + 15 reserved)	0 = Do Not Clear Error Flag 1 = Clear Error Flag
Address + 2 to Address +5	Command Area 1	See next page
Address +6 to Address +9	Command Area 2	See next page
Address +10 to Address +27	Reserved	Always 0

Module Control Data: Description

Output Disables: These bits can be used to disable or enable the corresponding module output points. The default is enabled.

Clear Error Flag: These bits can be used to clear the error code in Module Status data (see the Input Data section of this chapter). After using the clear error flag bit to clear an error, the CPU must then clear (0) the Clear Error Flag bit itself. Otherwise, the next command error will automatically be cleared on the sweep immediately after it is processed. This will result in command errors that go undetected.

Command Area 1:

Command Area 2: The High-speed Counter has two independent command areas, so two commands can be sent to the module at the end of each CPU sweep. The command in Command Area 1 is executed first. If identical commands with different values are sent to the module simultaneously, the data in Command Area 2 overwrites the data set by Command Area 1.

Even though the data is sent each sweep, the module acts on a command ONLY if the command has changed since the last sweep. If any part of a command changes, the module accepts the data as a new command.

Each command area is two Dwords in length. In each command area, the first Dword is the command and the second Dword is the data, if any, associated with the command.

Module Control Data Commands

The following table shows the format of all the commands that can be sent to a High-speed Counter module in Command Area 1 or 2.

Note that changes made using data commands are not retained through a power cycle, hot-swap, PLC clear, PLC reconfiguration, or reloading the module's configuration.

Command Definition	Command Data				Command		
	<i>Dword 1</i>				<i>Dword 0</i>		
	<i>Word 1</i>		<i>Word 0</i>		<i>Word 1</i>		<i>Word 0</i>
	<i>Byte 3</i>	<i>Byte 2</i>	<i>Byte 1</i>	<i>Byte 0</i>	<i>Byte 3</i>	<i>Byte 2</i>	
Null	n/a				n/a		0
Load accumulator	Accumulator value				n/a	Counter #	1
Load Low Range limit	Low Range limit value				n/a	Counter #	2
Load High Range limit	High Range limit value				n/a	Counter #	3
Load timebase	Timebase value in units of 100ns				n/a	Counter #	4
Load setpoint ON value	Setpoint value				Setpoint #	Counter #	5
Enable/Disable setpoint ON interrupt	Enable/Disable flag (1 = Enable, 0 = Disable)				Setpoint #	Counter #	6
Load setpoint OFF value	Setpoint value				Setpoint #	Counter #	7
Enable/Disable setpoint OFF interrupt	Enable/Disable flag (1 = Enable, 0 = Disable)				Setpoint #	Counter #	8
Load preload	Preload value				Preload #	Counter #	9
Load pre-scale	Pre-scale value (0 → 65535)				n/a	Counter #	10
Load accumulator increment	n/a	n/a	n/a	Increment value (-128 → 127)	n/a	Counter #	11
Load input filter	Filter value (0 = 5MHz, 1 = 500KHz, 2 = 50KHz, 3 = 5KHz, 4 = 30Hz)				n/a	Input #	12

Module Control Data Command Definitions

Null: This is the default data command. Because the Module Control data is transferred each PLC sweep, the Null command should be used when not executing a specific data command, to avoid inadvertent execution. All data is ignored with a Null command.

Load Accumulator: This command places a 32-bit value into a counter accumulator. The value must be within the Count Limits, or an error is returned and the command is ignored.

Load Low Range Limit:

Load High Range Limit: These two commands set the lowest and highest values between which a counter will normally operate. If the counter is configured for either Continuous or One-Shot Counting within Range, any counts that would cause the counter to go outside of these limits are ignored or cause the Accumulator to roll over to the High Limit. If the counter is configured for either Continuous or One-Shot Counting beyond Range, counting can continue past the Low Range or High Range limit. Fault Reporting can be enabled so the application program can check for Overrange and Underrange conditions and respond appropriately.

A Range Limit can be any 32-bit value with the following restrictions:

- The Low Range Limit must be less than the High Range Limit.
- the counter's Preload values must lie between the Low Range and High Range Limits when using the Within Range counting mode.

If any of these conditions is not met, an error is generated and the command is ignored. If the range between the new Low Range Limit and the High Range Limit excludes the Accumulator, the Accumulator is set to the Low Range Limit and no error is generated.

To avoid errors, always move the high limit first when shifting the limits up and always move the low limit first when shifting them down.

Load Timebase: This command sets the timebase in units of 100ns (this *differs* from the counter configuration timebase units, which can be 100ns, 1us, or 1ms). The timebase is the time during which the counter counts input pulses and then returns the value in the Counts per Timebase register. Any non-zero 32-bit value may be used as the timebase. The value is treated as an unsigned 32-bit integer. Do not load a negative timebase value, Negative values will produce unexpected results (for example, -1 would be treated as 4294967295).

Load Setpoint ON Value:

Load Setpoint OFF Value: These commands set the Setpoint Output's On and Off values. Setpoints can be any values within a counter's range. Moving a Setpoint outside the limits effectively disables the Setpoint.

Enable / Disable Setpoint ON Interrupt:

Enable / Disable Setpoint OFF Interrupt: These two commands enable or disable interrupts

resulting from Setpoint Output transitions. For example, if Setpoint ON interrupts are enabled, then a low-to-high transition of the Setpoint ON output generate an interrupt to the CPU.

Load Preload: This command changes the counter's configured Preload Value in the Accumulator when the Preload input trigger occurs. The value must be between the High and Low Range limits inclusive, or an error is returned and the command is ignored.

Load Pre-scale: This command loads a Pre-scale (divider) value from 1 to 65535) for a counter.

Load Accumulator Increment: The Accumulator Increment performs a one-shot adjustment to the accumulator. The one-shot increment may be performed at any time, even when counting at maximum rate. If the offset cause the counter to exceed its limits, the excess is treated just like any other overflow, i.e., in Continuous mode the Accumulator rolls over to the other limit and in Single-shot mode the Accumulator does not pass the limit.

Load Input Filter: This command loads a filtering value for an input. The filtering value can be: 5MHz, 30Hz, 50KHz, 500KHz, or 5KHz. Using a lower-frequency filter can reduce the effects of signal noise.

Output Control Data

The Output Control data contains commands to turn the module's external output points on or off. To use this data to control output operation, the source of an output must be configured as Control Data Reference.

The length of this data area is 32 bits. During module configuration, it can be assigned to any available reference in %Q, %M, or %T memory, or discrete I/O variables.

Output Control Data has the format shown below. Reserved bits should always be 0.

Module Reference Address	Data	Meaning
Address +0 bits	IC695HSC304: 7 input bits + 25 reserved IC695HSC308: 14 input bits + 18 reserved	0 = External Output is Off, 1 = External Output is On

Counter Control Data

Counter Control data contains commands to control operation of the module's counters. For High-speed Counter module IC695HSC304, the length of this data is 128 bits (4 counters with 32 Counter Control bits per counter). For module IC695HSC308, the Counter Control Data length is 256 bits (8 counters with 32 Counter Control bits per counter). During module configuration, this data can be assigned to any available reference in %Q, %M, or %T memory, or to discrete I/O variables. The format of this data is shown on the next page.

Counter Control Data Description

Strobe Triggers: If a Strobe source is configured to be Control Data Reference, the application program can set its Strobe Trigger bit to strobe the current counter Accumulator Value into the corresponding Strobe Register. This causes the module to set the Strobe Status bit in its input data.

Preload Triggers: If a Preload source is configured to be Control Data Reference, the application program can set its Preload Trigger bit to preload the corresponding Preload Value into the counter Accumulator. This causes the module to set the corresponding Preload Status bit in its input data.

Strobe Acknowledge: Setting one of these bits clears the corresponding Strobe Status bit. In "Strobe Overwrite with Acknowledge" mode, subsequent strobe pulses are ignored until this bit is used to clear the Strobe Status bit.

Preload Acknowledge: The application program uses these bits to clear the corresponding Preload Status bits. For example, if Preload 3 was triggered, the Preload 3 Status bit would be set. The Preload 3 Acknowledge can be used to clear the Preload 3 Status bit.

Counter Clear: For a User-Defined Counter only. If the Clear source is configured as Control Data Reference, this bit can be used to clear the counter Accumulator value to zero, or to the low range limit. See chapter 4 for more information.

Preload Disable: For a User-Defined Counter only, if the Preload Disable source is configured for Control Data Reference, the application program can use the Preload Disable bit to enable or disable all preloads on that counter.

Counter Disable: If the Counter Disable source is set to Control Data Reference, the application program can use this bit to enable or disable counting.

Strobe Disable: If a Strobe source is configured to be Control Data Reference, the application program can use this bit to enable or disable all strobes on the counter.

Direction (Clock Input Pair 1 & 2), Direction (Clock Input Pair 3 & 4): these bits are used when Clock Input 2 or Clock Input 4 inputs are assigned to Control Data Reference and the Clock Type is configured for Clock/Direction mode. This command determines whether a counter's accumulator increments or decrements in response to the appropriate change on its Count Pulse input. The direction may be set at any time.

Home Command: If the Homing feature is enabled for a Type C, Type D, or User-Defined Counter, the application program can use this bit to command a Homing operation. See chapter 4 for a description of Homing for Type C, Type D, and User-Defined Counters.

Counter Control Data Format for Each Counter

For each counter, the Counter Control data has the following format. Depending on the counter configuration, some bits may not be used. Unused bits are always 0.

Counter Reference Address	Data	Meaning
Address +0 bits	Strobe 1 Trigger	0 = Do Not Trigger Strobe, 1 = Trigger Strobe *
Address +1	Strobe 2 Trigger	
Address +2	Strobe 3 Trigger	
Address +3	Strobe 4 Trigger	
Address +4	Preload 1 Trigger	0 = Do Not Trigger Preload, 1 = Trigger Preload *
Address +5	Preload 2 Trigger	
Address +6	Preload 3 Trigger	
Address +7	Preload 4 Triggers	
Address +8	Strobe 1 Acknowledge	0 = Do Not Acknowledge Strobe, 1 = Acknowledge Strobe
Address +9	Strobe 2 Acknowledge	
Address +10	Strobe 3 Acknowledge	
Address +11	Strobe 4 Acknowledge	
Address +12	Preload 1 Acknowledge	0 = Do Not Acknowledge Preload, 1 = Acknowledge Preload
Address +13	Preload 2 Acknowledge	
Address +14	Preload 3 Acknowledge	
Address +15	Preload 4 Acknowledge	
Address +16	Counter Clear	0 = Do Not Clear the Accumulator to 0, 1 = Clear the Accumulator to 0 *
Address +17	Preload Disable	0 = Preloads are Enabled, 1 = Preloads are Disabled *
Address +18	Counter Disable	0 = Counts are Enabled, 1 = Counts are Disabled *
Address +19	Strobe Disable	0 = Strobes are Enabled, 1 = Strobes are Disabled *
Address +20	Direction Bit (Clock Input Pair 1 & 2)	0 = Up, 1 = Down
Address +21	Direction Bit (Clock Input Pair 3 & 4)	0 = Up, 1 = Down
Address +22	Home Command	0 = Home Command is Not Triggered, 1 = Home Command is Triggered (If Homing Feature is Enabled)
Address +23 to Address +31	Reserved	Always 0

* If Source is set to Control Data Reference; otherwise reserved and always 0.

Using DO I/O and Suspend I/O

Both the Do I/O and Suspend I/O program functions can be used with PACSystems RX3i High-speed Counter modules. Suspend I/O suspends I/O updates for the module. Do I/O immediately updates the module's I/O data when the function executes in the application program. Both of these functions operate according to the standard for PACSystems controllers and modules.

The DO I/O function can be used to update selected inputs or outputs for one scan, in addition to the normal I/O scan, while the program is running.

DO I/O can be used to write new counter output control values and to send commands to the module. The PLC CPU and High-speed Counter modules do not permit back-to-back DO I/O commands or normal output scans to overwrite output data before the module can read it.

If output DO I/O will overwrite the previous outputs that have not yet been consumed by the module, the DO I/O will discard the outputs and NOT pass power flow. The application must retry output DO I/O until successful, or retry later.

To support the data coherency requirements of the High-speed Counter, the CPU reads both the bit and word data when performing DO I/O functions that request only discrete data.

High-speed Counter sweep time is 0.5ms or better, so inputs and outputs are produced and consumed at that rate or better.

Using DO I/O with I/O Interrupts

If the PLC CPU is configured for Preemptive Interrupts and an RX3i High-speed Counter module needs to perform input DO I/Os during execution of the I/O interrupt, use of ALT mode input DO I/Os is recommended. Using non-ALT mode DO I/Os risks overwriting the interrupt status when a previous High-speed Counter interrupt is pre-empted. If that happens, the reason for the interrupt that was pre-empted is lost.

DO I/O Function Block Format

The DO I/O function has four input parameters and one output parameter. When the function receives power flow and input references are specified, the input points starting at the reference ST and ending at END are scanned. If a n input reference is specified, with no alternate destination, all High-Speed Counter input data is updated. Overwriting of all previous High-Speed Counter input data is only supported when no alternate location is specified. If a reference is specified for ALT, a copy of the new input values is placed in memory beginning at the alternate reference, and the regular input points are not updated; however only inputs from the specified reference table are copied.



The example DO IO function block above will update both the bit and word data for a High-speed Counter module with a %I starting reference of %I00001. When the DO IO function receives power flow and output references are specified, the output points starting at the reference ST and ending at END are written to the referenced counter module(s).

If outputs should be written to the output modules from internal memory other than %Q or %AQ, the beginning reference can be specified using the ALT input. If a discrete (%Q) reference is specified with no alternate source both the control (%Q) and command (%AQ) data are updated using the referenced High-speed Counter's %Q and %AQ data.

The example DO IO function block below will transfer 32 bits of discrete data from the alternate source location starting at %T1 to the High-speed Counter module configured with %I starting reference of %I00001.

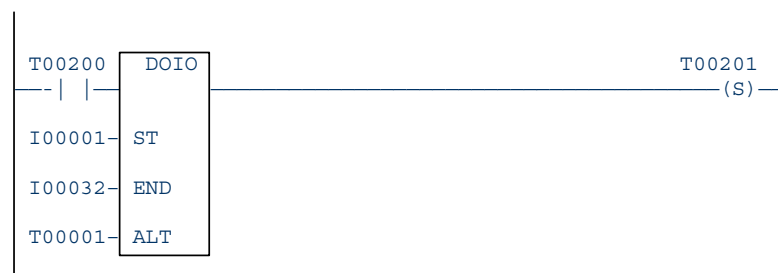

If previous outputs have not been consumed because DO I/O has been attempted within less than one module sweep since outputs were last written, then DO I/O terminates and does not pass power flow.

Chapter Using Interrupts

7

This chapter describes how interrupts can be used with PACSystems RX3i High-speed Counter modules.

- Interrupt Handling
- Types of Interrupts
 - External Input Transition Interrupts
 - External Output Circuit Fault Interrupts
 - Counter Status Interrupts
- Masking and Unmasking Interrupts with SVCREQ 17
- Suspending and Resuming Interrupts with SVCREQ 32

Interrupt Handling

An IC695HSC304 module can provide up to six I/O Interrupts; an IC695HSC308 module can provide up to ten I/O Interrupts.

If an interrupt condition occurs, the High-speed Counter module sends a subset of input data needed to process the interrupt. The CPU suspends its current activity, updates the appropriate input data (%I, %AI, etc), then executes the interrupt logic.

- When a counter interrupt occurs, the 32 bits of counter status data and 7 dwords of counter register data are updated. Only those two areas are updated.
- When an input transition interrupt occurs, the 16 bits of input status data and the 16 bits of input interrupt status data are updated. Only those two areas are updated.
- When an output interrupt occurs, only the 16 bits of output interrupt status data are updated.

If multiple interrupt events occur before an interrupt is sent to the CPU, the status flags for each interrupt event are set when the next interrupt is sent to the CPU. The I/O data is updated to the values for the most current event.

The module does not send additional interrupt conditions on the same I/O Interrupt trigger if a previous condition is still being processed. For example, if a counter's Setpoint interrupt condition is pending and a Rate of Change interrupt condition is detected for the same counter, the module waits until the Setpoint processing completes before sending the Rate of Change interrupt.

If multiple interrupt conditions occur while waiting, the module latches all conditions and sends the indications for all conditions in one interrupt. If an interrupt condition repeats while waiting for a pending interrupt to complete, the repeating condition is still latched only once. For example, if a Rate of Change interrupt condition is detected twice while waiting for a Setpoint Interrupt to complete, the Rate of Change Interrupt is still sent only once after the Setpoint Interrupt completes.

When an I/O Interrupt occurs and input data is updated, the updated data contains only the most current High-speed Counter data plus any latched interrupt conditions. That means the exact counter state, counter register value, or external input state at the time of detection may not be present in the I/O Interrupt data. For example, if an Input Transition interrupt is configured to be Rising-Edge on Input 2, the Input 2 state is 1 at the time the interrupt condition is detected. However, if sending the interrupt condition to the PLC CPU is delayed because of a previous condition, the Input 2 state might return to 0 before its condition is sent to the PLC CPU. The I/O Interrupt data would indicate that an Input 2 interrupt occurred in the External Inputs Interrupt Status, but the current value in External Inputs State could be 0.

Setting I/O Interrupt Priority

Each interrupt trigger can be assigned a priority using the Preemptive Scheduling feature of the CPU. With Preemptive Scheduling, the maximum number of interrupts is 32. A priority can be assigned to each interrupt when scheduling a block. Interrupts of a higher priority can preempt an interrupt of lower priority that is already executing.

If the Scheduling mode is set to Normal (default), the maximum number of interrupts is 80. In this mode, if the CPU receives one or more interrupts while executing an interrupt block, it finishes executing the currently executed interrupted block and then executes the others in the order in which it received them.

Types of Interrupts

There are three basic types of Interrupts:

- Transition Interrupts for the module's external inputs, configured on the Inputs tab.
- Circuit Fault Interrupts for the module's external outputs, configured on the Outputs tab.
- Counter Status Interrupts for each counter, configured on the CFG-Counter tabs.

Input Transition Interrupts

Any of the module's external inputs can be configured to trigger an I/O Interrupt every time it transitions. Optional input transition interrupt conditions include: Rising Edge, Falling Edge, or Both Edges options for each external input.

The module reports Input Transition Interrupts to the CPU in its I/O Status Data (see chapter 6 for details). If an Input Transition Interrupt occurs, the module updates the 16 bits of External Interrupt Status with bits that identify the input transitions causing the interrupt. The module also updates 16-bits of External Inputs data with current state of all inputs.

Output Circuit Fault Interrupts

Each of the module's external outputs can be configured to trigger an I/O Interrupt if a circuit fault (short-circuit or open-circuit) occurs. If an Output Circuit Fault Interrupt occurs, the module updates the 16 bits of Output Circuit Fault data with current status of all output circuit faults.

Counter Status Interrupts

For each counter, Counter Status Interrupts can be individually configured for: Overrange, Underrange, Encoder Fault, Overflow, Underflow, Rate of Change, and Setpoint On/Off Conditions. Setpoint On/Off Interrupts are described in more detail on the next page. If an interrupt condition occurs, the module sets the corresponding bits in the Counter Status data it sends to the CPU.

Setpoint On/Off Interrupts

Counter Status Interrupts can be individually enabled for each Setpoint Output On or Off transition. When the Setpoint Output changes state, if the corresponding interrupt is enabled, the module sends its current input data to the CPU, which then executes the interrupt logic.

For example, an output has its Setpoint On Interrupt enabled. The counter's Low and High Range limits are 0 and 10. The output is configured to have a Setpoint On value of 5, and a Setpoint Off value of 10. The counter will generate an interrupt when the Accumulator increments to 5. In an RX3i High-Speed Counter module, the Output Disable bits do not affect the counter's Setpoint Output state. This operation is different from a Series 90-70 High-Speed Counter.

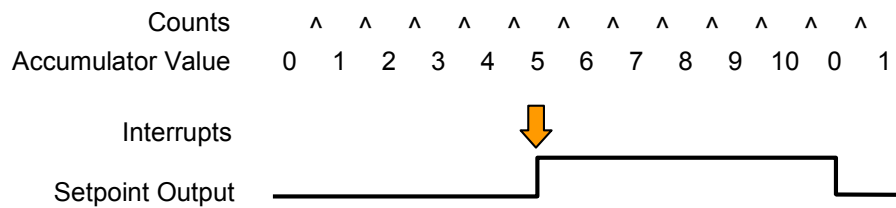

The Interrupt Logic

If a High Speed Counter module has any interrupts enabled, an Interrupt block must be defined for the module. There can be one Interrupt block for each counter, one for input transitions, and one for output circuit faults. The maximum number is six for module IC695HSC304 or ten for module IC695HSC308.

For counter interrupts, the first bit of each counter's Counter Status Data is used as its reference memory trigger location. For example, if the module's Counter Status Data is configured to start at %I1, the counter interrupt triggers are located at %I1, %I33, %I65, etc.

The execution of a block triggered from an interrupt supersedes the execution of the main program sequence. Execution of the main sequence is resumed after the interrupt block completes.

Eight bits from Counter Status 16-23 are Setpoint Interrupt Status. These eight bits are only set during interrupts and should not be tested outside the interrupt block.

Six bits from Counter Status 24-29 can be used for interrupt status but also show current counter conditions. Interrupts only execute for these conditions when the interrupt is enabled and the status bit transitions from 0 to 1.

For Input Transition interrupts, the first bit of I/O Status Data is the trigger.

For Output Circuit Fault interrupts, the 48th bit of I/O Status Data is the trigger.

Masking I/O Interrupts

To guarantee data coherency in the application program, it may be necessary to Mask or Suspend a counter interrupt before reading counter status bits and register values. Because I/O Interrupts can occur at almost any time, counter status bits and registers can be modified during execution of the main logic task.

MOVE_DWORD and some other logic functions guarantee at least a dword of coherency when processing of 32-bit counter status data or individual register values. However, the only way to assure coherency across registers and the status bits is to Mask or Suspend a particular counter's I/O Interrupt. To keep the Mask time to a minimum, the application program can copy the counter's status and registers to a different reference memory location for processing. That allows the interrupt to be Unmasked quickly, and processing of the copied data can occur without additional coherency problems.

The application program can Mask and Unmask the execution of I/O interrupts using SVC_REQ #17, or Suspend/Resume using SVCREQ #32. If an interrupt is masked, it is ignored. Any occurrence of it is discarded while it is masked. If an interrupt is suspended the interrupt is blocked, but the module continues to queue or latch interrupt conditions. When resumed, any queued conditions are sent as an interrupt.

Masking and Unmasking Interrupts with SVCREQ 17

Use Service Request 17 to mask or unmask interrupts from the High Speed Counter module. When this service request is active, the CPU ignores any interrupts from the specified counter and updates the I/O normally, as if no interrupts had been configured for the module.

Service Request 17 Parameter Block

Service Request 17 has a three-word parameter block that specifies whether interrupts are to be enabled or disabled, and identifies the device for which interrupts are to be disabled.

<i>Offset</i>	<i>Description</i>
Address	0 = Interrupts Unmasked 1 = Interrupts Masked
Address + 1	70 (%I memory)
Address + 2	First reference of selected interrupt (this is the same reference as the Interrupt Logic Block trigger).

Example

The example ladder logic on the below initializes two parameter blocks using a Block Move function, then masks interrupts before Compare and Move functions on a High Speed Counter's %AI data. In this example, the counter uses input references %I33 and %AI1. The parameter block starting at %R1 is used to mask interrupts. The parameter block starting at %R4 is used to unmask interrupts.

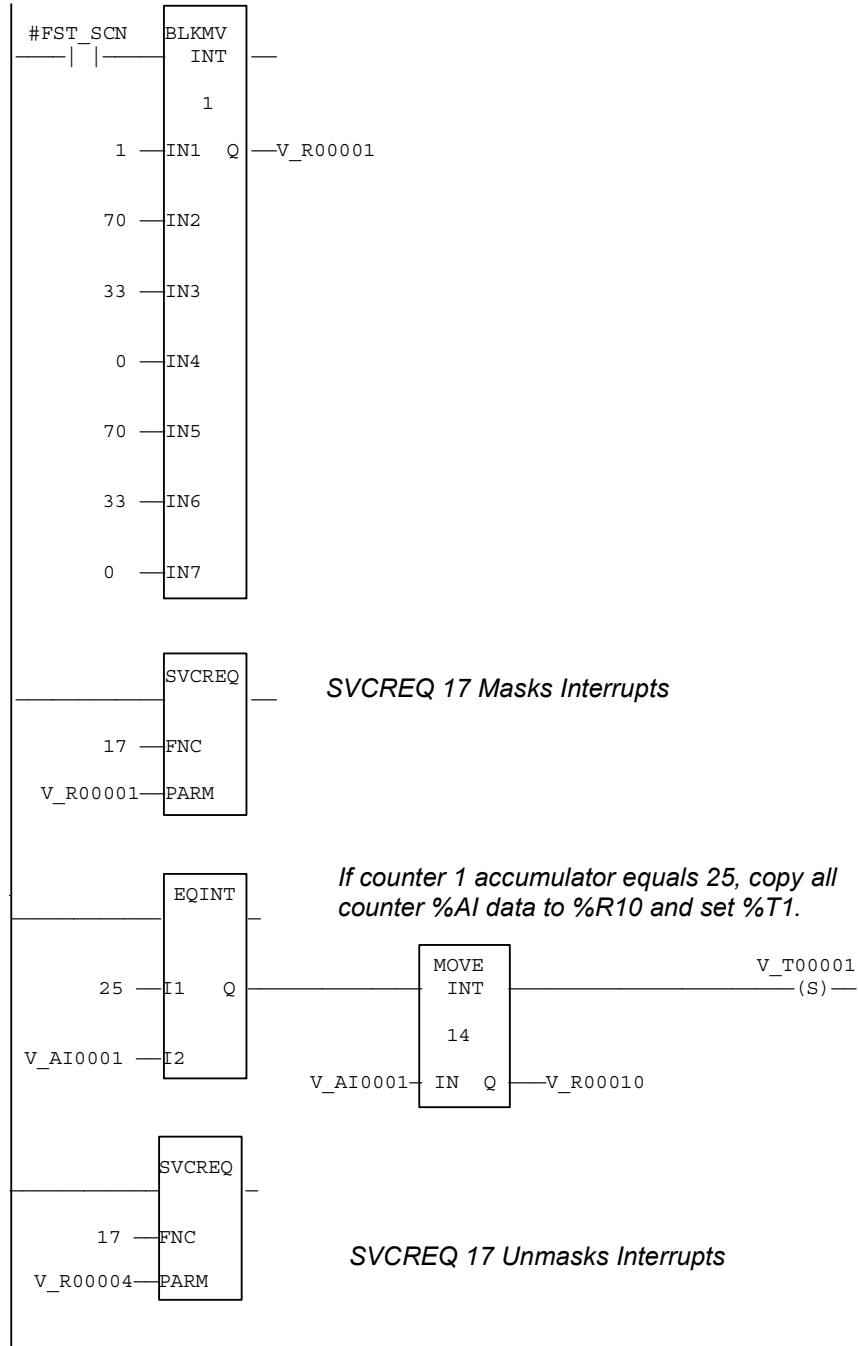

Suspending and Resume I/O Interrupts Using SVC_REQ 32

I/O interrupts, unless suspended or masked, can interrupt the execution of a function block. Use SVC_REQ 32 to suspend a set of I/O interrupts. Occurrences of these interrupts are queued until the interrupts are resumed. The CPU informs the module that its interrupts are to be suspended or resumed. The I/O module's default is resumed. The Suspend applies to all interrupt conditions that are associated with an interrupt block. For example, suspending the interrupt trigger for Counter 3's interrupt block suspends all interrupts (setpoints, range limits, etc...) for Counter 3. Interrupts are usually suspended and resumed within a single sweep.

Service Request 32 Parameter Block

Service Request 32 has a three-word parameter block that specifies whether interrupts are to be suspended or resumed, and identifies the interrupts to be disabled.

Offset	Description
Address	0 = resume interrupt 1 = suspend interrupt
Address + 1	70 (%I memory)
Address + 2	First reference of interrupt (this is the same reference as the Interrupt Logic Block trigger).

Example

Interrupts from the counter whose starting point reference address is %I00065 are suspended while the CPU solves the logic of the third rung.

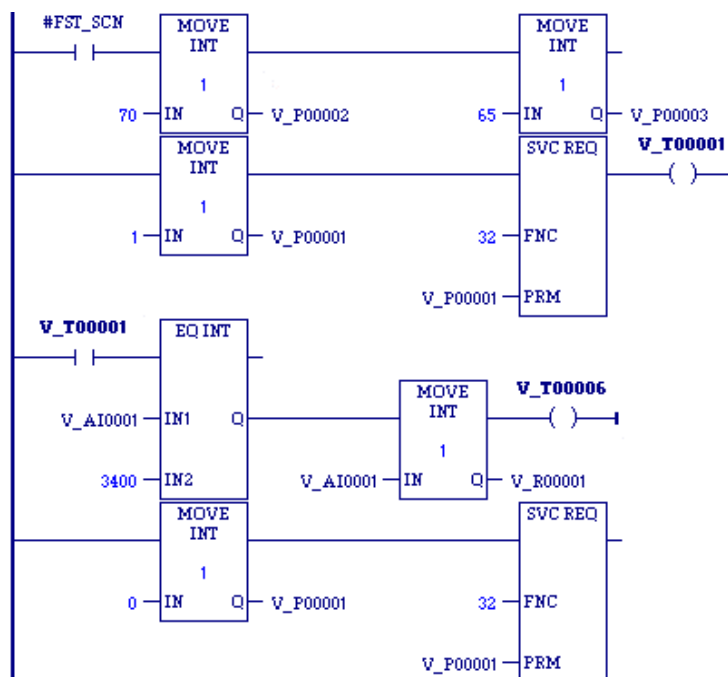

Chapter Application Examples

8

This chapter describes the following High-speed Counter applications:

- Monitoring and Controlling Differential Speeds
- Direction-Dependent Positioning
- RPM Indicator
- Tolerance Checking
- Pulse Width Timer
- Measuring Pulse Time
- Measuring Total Material Length
- Material Handling Conveyor Control
- Timing Pulse Generation
- Dynamic Counter Preloading
- Carousel Tracking

Monitoring and Controlling Differential Speeds

Many industrial applications require machines such as cutters, conveyors, or nip rolls to operate at precise differential speeds. A Type C Counter or User-Defined Counter, both of which provide differential counting, can be used for this application. If a User-Defined Counter is selected, it must be configured to have 4 Clock Inputs.

In this example, the pulses representing the speed of each machine are separately fed into the plus and minus loops of the counter. The Accumulator automatically tracks the speeds of the two machines and indicates the difference between them (see the description of differential counting in chapter 3). The sign of the Accumulator Value indicates which pulse stream count is greater and the Accumulator Value indicates the total accumulated count difference. The Counts per Timebase register indicates the present rate difference, its sign indicates which rate is greater.

Depending on the count signal types, each channel of the counter can be independently programmed to operate in any of its three modes:

1. Pulse/Direction
2. Up/Down
3. A quad B

The sign (+ or -) and magnitude of the deviation from the desired difference can be used as feedback to provide automatic control for the speed regulation of the machines.

Direction-Dependent Positioning

Some applications require direction-dependent positioning. An example is an operation where a crane on tracks has to perform certain maneuvers while traveling 100 feet in one direction and different ones while traveling 100 feet in the reverse direction.

This example uses two Type B counters, both configured to operate in A Quad B mode. Both counters should be driven by the same A Quad B signals and connected so they count in opposite directions when the crane is moving.

The Count Mode, range limits and Preload Value are set so that the Setpoint Outputs are direction-sensitive. In this example, this is done by using the One-Shot mode and preloading counter 2 so that it only counts when the crane is moving in the reverse direction (right to left).

The counters are both preloaded at the start point. Counter 1 counts up from 0 to 100 for the left-to-right direction, and counts down for travel in the right-to-left direction. Counter 2 counts up from (-100 to 0) only when the crane travels from right to left.

In this example, counter 1 is configured with a preload value of 0. An On condition for Setpoint 1 is selected, which will turn on a loading device when the crane has traveled 75 feet to the right. Setpoint 2 (also for Counter 1) is selected to come on when the crane has traveled 100 feet to the right. The direction of travel is reversed at the stop point, and as the crane travels back from right to left, the ON Setpoint 1 of counter 2 activates an unloading device when the crane has traveled 40 feet to the left (ON Setpoint is -60).

Finally, Setpoint 2 of counter 2 turns its output on when the crane has traveled 75 feet to the left (ON Setpoint is -25).

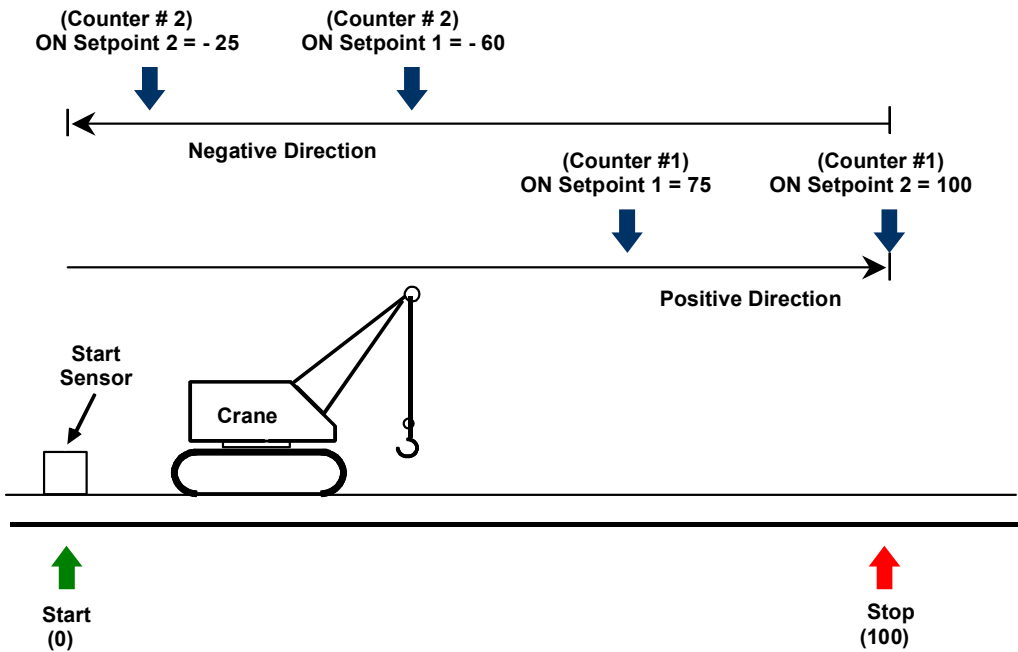

Suggested Configuration

Number of Counters	Two
Counter Type	Type B (both counters)
Counter Operating Mode	A Quad B
Count Mode	One-Shot (both counters)
Counter 1 Preload	0
Counter 2 Preload	-100
Counter 1 Limits	0 to 100
Counter 2 Limits	-100 to 0

Operating Count Directions

Counter Number	Crane Direction	Count Direction
Counter 1	→	UP
Counter 2	→	Not counting
Counter 1	←	DOWN
Counter 2	←	UP

Output Conditions

Counter 1:		
Output 1	ON for Counter 1 ≥ 75 OFF for Counter 1 < 75	
Output 2	ON for Counter 1 ≥ 100 OFF for Counter 1 < 100	
Counter 2:		
Output 3	ON for Counter 2 ≤ -60 OFF for Counter 2 > -60	
Output 4	ON for Counter 2 ≤ -25 OFF for Counter 2 > -25	

RPM Indicator

A Type A, B, C, D, or User-Defined Counter can be used as a position/motion indicator when connected to a feedback device (such as an encoder) that is coupled to a rotary motion. RPM indication can be obtained directly from the counter's Counts/Timebase register for some applications, or the application program can calculate RPM using the equation below.

$$RMP = \frac{CTB}{PPR} \times \frac{1}{T}$$

- where: CTB = counts/timebase reading from the counter
- PPR = pulses/revolution produced by the feedback device
- T = timebase expressed in minutes

If 1/T divided by PPR is some integer power of 10, the Counts per Timebase register gives a direct reading of RPM with an assumed decimal placement. Longer timebase settings give better RPM resolution. This is illustrated in the following examples.

Example 1

If feedback produces 1000 pulses/revolution, Counts per Timebase = 5212, and the timebase is configured for 600 ms:

$$\begin{aligned} \text{then } T &= 600 \text{ ms} / 60000 \text{ ms/min} = .01 \text{ and } 1/T = 100 \\ \text{RPM} &= 5212 / 1000 \times 100 = 521.2 \end{aligned}$$

The Counts per Timebase register reading is RPM with .1 RPM resolution.

Example 2

Assume the same conditions as example 1, except the timebase is now set to 60 ms, which gives

$$T = 60 / 60000 = .0001 \text{ and } 1/T = 1000.$$

Since the motion is turning at the same speed as in example 1, the Counts per Timebase register reading now equals 521,

$$\text{and RPM} = 521/1000 \times 1000 = 521.$$

The Counts per Timebase register reading is now RPM with 1 RPM resolution.

Tolerance-Checking

A counter can accurately measure the length of parts on a conveyor for tolerance-checking. This application uses a pulse feedback device coupled to the conveyor. Each pulse from the device represents a known length of conveyor movement.

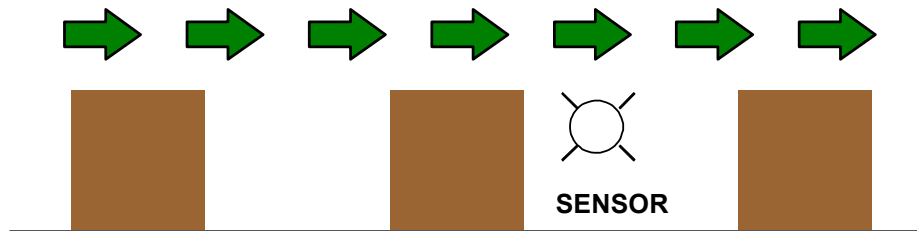

For this example, a Type B counter is used. The conveyor pulse feedback device is connected to the counter inputs, and the same part-sensing signal is connected to both strobe inputs. The first strobe input is configured to be active on the leading edge and the second on the falling edge. Then as each part passes through the sensor, its length is indicated by the difference between the two strobe register readings. Multiplying the difference by the known distance represented by each pulse gives the length in measurement units for comparison against the allowable tolerance. Parts that are out of tolerance can be marked or separated from the rest.

Pulse Width Timer

There are two different ways to measure Pulse Width timing using an RX3i High-Speed Counter module:

- Using a Type B, C, E, or User-Defined Counter, with the pulse used as a source for the Counter Disable input. Type B, which is less complex than the other types, is most suitable for this application.
- Using a User-Defined Counter, which provides Sequenced Strobing and a Counter Clear Input.

Both methods use a pulse stream with a known frequency as a reference. The reference frequency should be at least 10 times greater than the pulse rate to be measured. The reference pulse can come from an external source or from the module's own internal 2MHz oscillator. If the internal oscillator is used, no external connection is required. A Pre-scale (Divider) value should be configured for the internal oscillator to scale its count rate down.

Pulse Width Timing Using Counter Disable

The pulse that is to be measured is configured as an External Input source for the Counter Disable input. Its Item Number would be the Input Number of the external input point. The pulse Counter Disable is available with a Type B, Type C, Type E, or User-Defined Counter. Type B is recommended for this application.

The counter's Clock Input 1 Source is configured as Internal (2MHz).

When the pulse input being measured is On (or Off, as configured), the Counter Disable input suspends updating the count value in the Accumulator. When the pulse input is Off (or On, as configured), the count value in the Accumulator counts at the pre-scaled rate of the internal oscillator.

Pulse Width Timing Using Sequenced Strobing

The Sequenced Strobing feature can also be used to measure Pulse Width. The internal oscillator is the source of the Count 1 Input.

The Strobe 1 Input source (configured for triggering on rising, falling, or both edges) is set to External Input. Its Item Number is the Input number of the pulse that is to be counted. When the strobe is triggered by the pulse, the pulse width count is captured. In Sequenced Strobing, the Strobe 1 Input strobes the current reference pulse value from the Accumulator into the next of four available Strobe registers.

The application program needs to read the strobe values and clear the Strobe Status bits by setting corresponding Strobe Acknowledge bits so that additional Strobed values can be stored. The application program should also:

1. Find the difference between two successive sets of Strobe Register Values.
2. Divide the number of pulses in the first Strobe Register value by the number of pulses in the next Strobe Register value. This gives the ratio between the pulse rates.
3. To find the measured pulse rate, the program should divide the reference pulse by the ratio between the pulse rates.

The Counter Clear Input can be used to reset the current measurements and counter accumulator simultaneously..

Generating a PWM Output Using the Setpoint Registers

Using Setpoint Outputs, a Pulse-Width Modulated output pulse can be generated using simple Type A counter, configured to count Up.

Each Counter Type controls up to four Setpoint Outputs, each of which can be configured to turn On and Off in response to the current count value in the Accumulator.

For this application, the setpoint values are configured so that as each Setpoint Output goes Off, the next Setpoint Output goes on. As a simple example configuration:

Setpoint 1 On = 0, Setpoint 1 Off = 100
Setpoint 2 On = 100, Setpoint 2 Off = 200
Setpoint 3 On = 200, Setpoint 3 Off = 300
Setpoint 4 On = 300, Setpoint 4 Off = 400

The pulse to be measured is configured as the source of Count Input 1. The reference pulse can come from an external source or from the module's own internal 2MHz oscillator. If the internal oscillator is used, no external connection is required. A Pre-scale (Divider) value should be configured for the internal oscillator to scale its count rate down.

As the counter counts up past each On value, the corresponding Setpoint Output is turned On. As the counter counts up past each Off value, the corresponding Setpoint Output is turned Off.

Setpoint Output signals can be configured for any External Output on the module. . For example, the Setpoint Outputs might all be assigned to Output #2 . The output states are always reported back to the CPU in their corresponding input I/O bits. If more than one Setpoint Output is assigned to the same External Output, the signals are logically "OR-ed" to drive the physical output.

Measuring Pulse Time

The ON/OFF time of input pulses can be accurately measured using a Type B counter. This can be done by configuring the Internal Oscillator input into Counter 1 and using the two Strobe inputs to capture the count value on each of the input pulse edges.

For example, assume that an input pulse needs to be measured to the nearest 0.1 milliseconds; configure the High-speed Counter as follows:

Counter: Type B
Clock Input 1: Internal Oscillator (2MHz)
Prescale: 200

For Counter 1:
Mode = Continuous
Strobe 1 Edge = Rising Edge Strobe 1: External Input (Point #)
Strobe 2 Edge = Falling Edge Strobe 2: External Input (same as Strobe 1)

The pulse signal is connected to both Strobe inputs. When the signal occurs, its duration (in tenths of ms) is now given by [Strobe Reg 2 - Strobe Reg 1] for positive going pulses or [Strobe Reg 1 - Strobe Reg 2] for negative going pulses.

If the pulse spans the counter rollover point, the calculation is more complex. In that case, it may be better to preload the counter to 0 shortly before the pulse is measured.

If only a positive-going pulse is measured, it could also be connected to the preload input. The Strobe Register 2 reading would now give the pulse length directly.

Measuring Total Material Length

The total length of multiple pieces of material, such as plate glass, plastic strips, or lumber, can be measured using a Type B counter.

This application uses an encoder geared to a transport conveyor to provide the count input increments, and a sensor to detect material as it passes.

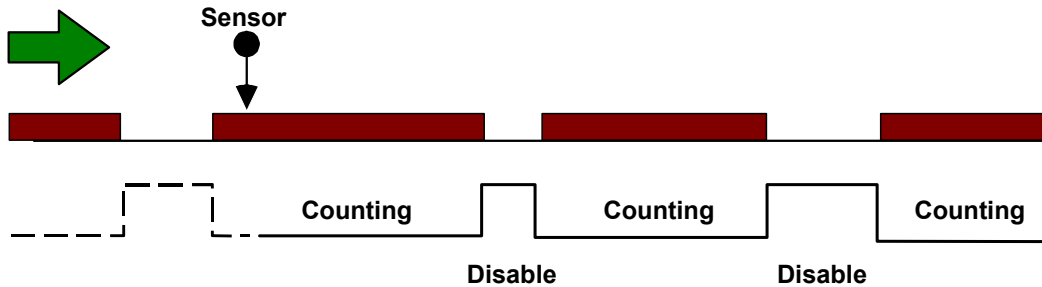

The encoder is connected to the counter's Count 1 Input. The sensor is source of the Disable Input.

Count inputs from the encoder increment the Accumulator only while a piece of material is passing through the sensor. The total length of all pieces is accumulated until the counter is reset (Preloaded) for the start of a new batch. The application program can convert the count units from the accumulator to the actual units of length being measured.

Material Handling Conveyor Control

When transported material must be stopped momentarily for inspection or modifications, the High-speed Counter's Setpoint outputs can control conveyor slowdown and stop points.

An encoder geared to the transport conveyor provides the count input increments. A sensor detects material as it passes on the conveyor.

For this application, it is necessary to determine where the material should begin to slow down, where the material should stop, and how many encoder counts are equivalent to each of these two distances.

A Type B counter can be used.

Setpoint Output 1 is configured to turn on at the slowdown point, by entering the number of counts from the sensor to the point where slowdown should begin.

Setpoint Output 2 is configured to turn on at the stop point, by entering the number of counts from the sensor to the inspection station.

The sensor is connected to the Preload Input of the counter to restart the counter at 0 for each piece of material that passes (only one piece can be between the sensor and the stop point in this configuration).

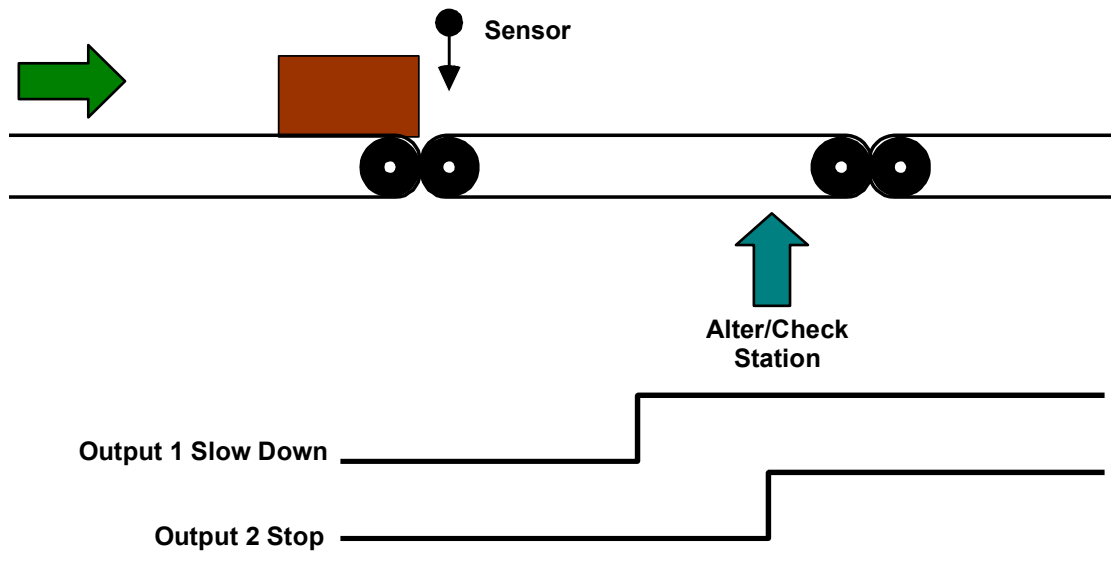

Timing Pulse Generation

Applications requiring an accurate timing pulse can use a High-speed Counter to generate the pulse at the required frequency.

For this example, a pulse of 50ms duration is needed every 1/2 second. A Type A counter is used with the following settings:

- Clock Input 1 Source – Internal (2MHz)
- Prescale Divider = 200
- Count Mode = Continuous within Range
- Upper Range limit = 4999
- Lower Range limit = 0
- Setpoint 1 ON = 4499
- Setpoint 1 OFF = 0

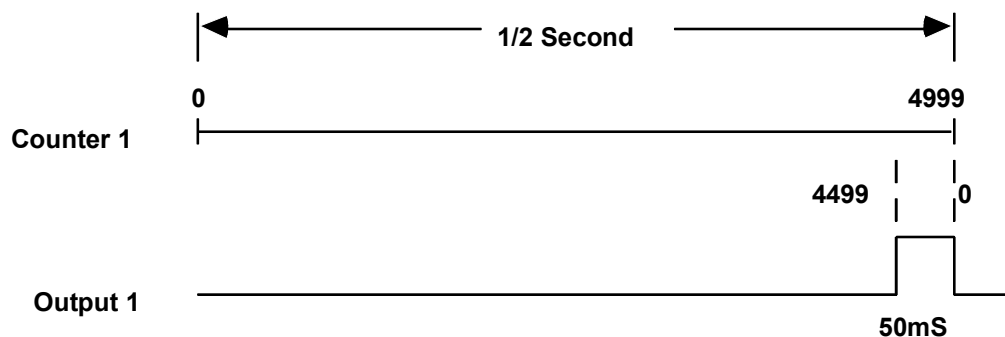

The counter's upper limit of 4999 represents 5000 counts, the number of counts in 1/2 second at 10kHz.

Setting the lower limit to 0 establishes the counter start point for each output pulse period. The On Setpoint, 4499, determines that 4500 counts will pass before the beginning of the output pulse. Setting the Off Setpoint to 0 turns off the output pulse when the Accumulator reaches 5000 counts.

Dynamic Counter Preloading

Applications using a High-speed Counter to track the position of a material conveyor or machine slide may need to be preloaded accurately at a given reference point while in motion. Simply connecting a limit switch to the counter's Preload Input does not give repeatable, accurate results because errors are introduced by:

- 1. Variations in the actuation point of the limit switch and
- 2. Preload Input Filter delay when actuated at different speeds.

For accurate repeatability, the Home feature of a Type C or User-Defined counter can be used. This application requires a marker pulse (usually 1 per revolution) from the position feedback device (encoder). The limit switch should be placed so that it will be encountered approximately halfway between marker pulses. When the limit switch is reached, the next marker pulse causes the High-speed Counter to preload the Accumulator with the desired value. The limit switch should be connected to the High-speed Counter's Enable Home input.

The operation is as follows:

- 1. As the conveyor or slide moves toward the reference position, the CPU issues the Home Command (by setting the Home command bit in the Counter Output data). The Homing feature must have already been enabled in the counter configuration.
- 2. The Enable Home limit switch is actuated. This informs the counter that the next marker pulse will be the reference marker.
- 3. When the next (reference) marker is reached, the counter automatically transfers the Home value to the counter Accumulator.
- 4. The module informs the CPU that Home position has been found by setting the Home Found Counter Status bit.
- 5. The CPU may then clear the Home Command output bit. The next time the Home Command is set, the counter will remove the Home Found indication.

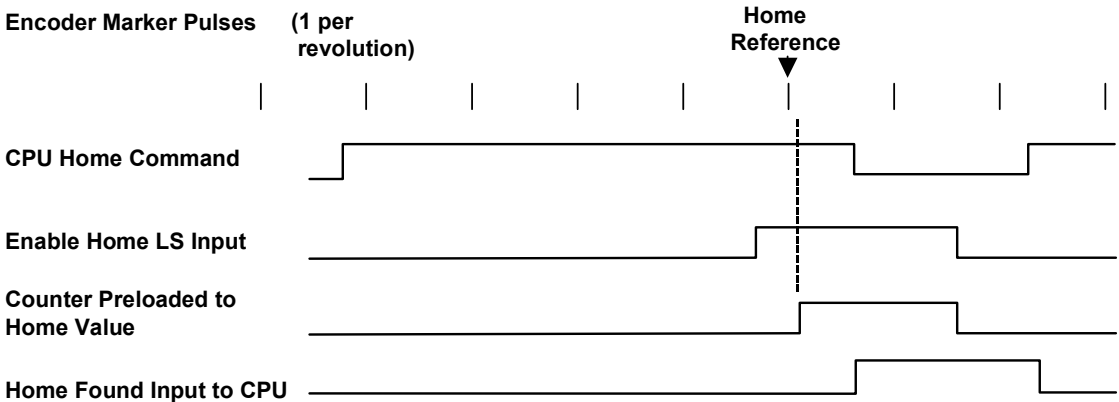

Carousel Tracking

Items in a rotating carousel can be tracked and retrieved using a High-speed Counter. A feedback device coupled to the carousel rotation can be used to provide up/down count inputs. The counter limits are configured so that the increments produced by one complete revolution of the carousel cause one full cycle of the counter.

A Type C or User-Defined counter can be used for this application. The counter's homing capability makes it possible to synchronize the counter with the carousel position at a defined home location after powerup. From then on, any rotation of the carousel is tracked by the counter. Since the relative location of all entrance and exit points to the home position is known, the CPU can record the pocket location of each item entering the carousel. It can command any pocket to any exit for item retrieval.

If there are up to 3 entrance points, a different Strobe Input can be used to indicate when a pocket is loaded from each entrance. When the CPU detects the Strobe Set flag, it can record the pocket position into a memory table and mark it full. (The CPU records the pocket position by reading the value from the Strobe Register, then adding or subtracting the entrance offset from the home location.)

To retrieve an item from a particular exit, the CPU can locate the nearest full pocket to that exit, and generate the required rotation command to the carousel.

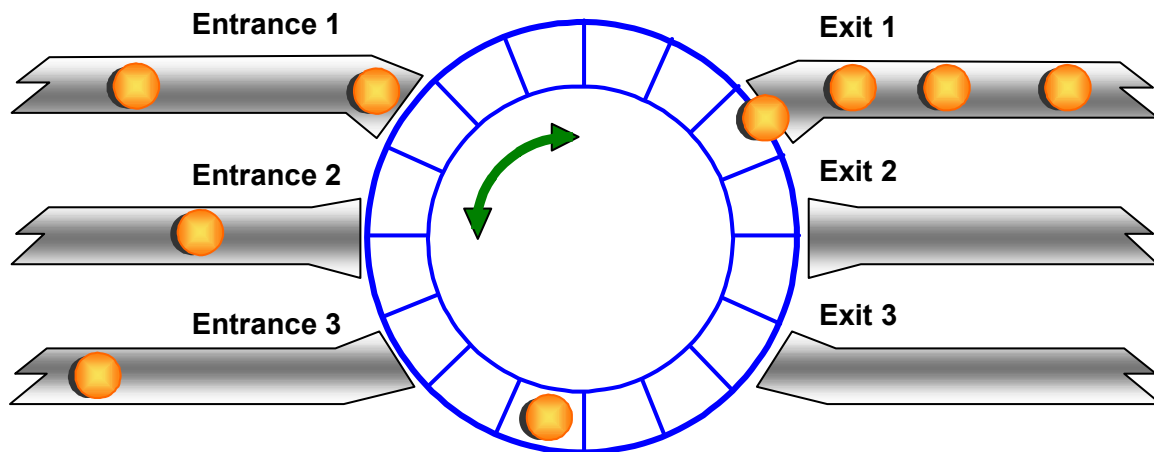

A

A Quad B Mode, 3-10
Accumulator register, 1-4, 3-3
Application examples
 carousel tracking, 8-14
 direction-dependent positioning, 8-3
 dynamic counter preloading, 8-13
 material handling conveyor control, 8-11
 measuring pulse time, 8-9
 measuring total material length, 8-10
 monitor/control differential speeds, 8-2
 rpm indicator, 8-5
 timing pulse generation, 8-12
 tolerance checking, 8-6
Applications, 1-12
ATEX, 1-2

B

Backplane required, 1-2

C

Carousel tracking, 8-14
Catalog numbers of modules, 1-2
CE, 1-2
Clear Counter Input, 4-15
Clear error bit, 6-15
Clock Type, 3-7
Clock Z Input, 4-13
Clock/Direction Mode, 3-9
Configurable Counter Features, 1-7
Continuous Counting Mode, 3-5
Count Down to Zero Pulse Mode, 4-18
Count Limits, 3-4
Count Mode, 3-5, 5-14
Count Mode for the Type E Counter, 4-9
Counter Control Data, 1-6, 1-10
Counter Disable, 3-4
Counter Register Data, 1-6, 1-9
Counter Sources, 1-8
Counter Status Data, 1-6, 1-9
Counter Types, 1-5, 4-1
Counting during power cycle, 1-2
Counting range, 1-4
Counts per Timebase register, 1-4, 3-12
Current specifications, 1-4

D

Data
 updating I/O data with DOIO function, 6-17
Data commands, Type A counter
 load accumulator increment, 6-14
 load low limit, 6-13
 load timebase, 6-13
Data Handling, 1-9
Data, %I for Type B counter
 preload status, 6-15
Data, %I for Type C counter
 home found, 6-6
Data, %Q for Type A counter
 clear error bit, 6-15
 reset preload bit, 6-15
Differential Counting, 3-11
Documentation, 1-1
DOIO function
 description of, 6-17
 example of, 6-18
 function block format, 6-18
Dynamic counter preloading, 8-13

E

Encoder Connections, 2-6
Error, quadrature, 3-10

F

Field Wiring, 2-2, 2-3

H

Homing Operation of Type C Counter, 4-5
Homing Operation of Type D Counter, 4-7
Homing for User-Defined Counter, 4-16
Hot insertion, 1-2

I

I/O Interrupts, 1-11
I/O Status Data, 1-6, 1-9
Input Settings, configuration, 1-6
Internal counters, 1-4
Internal Elements of a High-Speed Counter, 3-2
Interrupts, 1-11
Isolation, 1-4

M

- Material handling conveyor control, 8-11
- Measuring pulse time, example of, 8-9
- Measuring total material length, 8-10
- Module Control Data, 1-6, 1-10
- Module Settings, configuration, 1-6
- Module Status Data, 1-6, 1-9
- Monitoring and controlling differential speeds, 8-2

O

- One-Shot Counting Mode, 3-5
- Output Control Data, 1-6, 1-10
- Output Settings, configuration, 1-6

P

- Positioning, direction-dependent, 8-3
- Preload Disable, 3-14, 4-16, 4-18
- Preload Register, 1-4
- Preload Sources, 3-13
- Preload Status Bit and Preload Acknowledge Bit, 3-14
- Preloads, 3-13

Q

- Quadrature error, 3-10

R

- Rate of Change Monitoring, 3-12
- Reset preload bit, 6-15
- Response Output Point, 4-10
- Reverse Polarity protection, 1-4
- RPM indicator, example of, 8-5

S

- Sequenced Strobing, 3-17
- Sequenced Strobing for the Type E Counter, 4-11
- Sequenced Strobing for the User-Defined Counter, 4-17
- Service requests
 - 32, suspend/resume IO interrupt, 7-9
- Setpoint Interrupts, 3-20
- Setpoint On and Off Values, 3-19
- Setpoints, 3-18
- Single-shot counting configuration, 5-14

- Sources, 1-8
- Specifications, 1-3
- Strobe Disable Input, 3-16
- Strobe Register, 3-15
- Strobe Register Resets, 3-17
- Strobe Status Bit, 3-16
- Strobe Triggers, 3-15
- Strobing Options for the User-Defined Counter, 4-16

T

- Terminal Blocks required, 1-2
- Timing pulse generation, 8-12
- Tolerance checking, example of, 8-6
- Transducer Connections, 2-6
- TTL Open–Collector Input Devices, 2-8
- Type A Counter, 4-2
- Type A, B, C, D, E, Z counters, 1-5
- Type B Counter, 4-3
- Type C Counter, 4-4
- Type D Counter, 4-6
- Type E Counter, 4-8
- Type Z Counter, 4-12
- Typical encoder connections, 2-7

U

- UL/CUL, 1-2
- Up or Down Counting, Type A, 3-7
- Up/Down Counting, 3-8
- User-Defined Counter, 1-5, 4-14

V

- Voltage specifications, 1-4

W

- Wiring for TTL Open–Collector Input Devices, 2-8