

IC200ALG432 **Analog Mixed Module, 12 Bit +/-10VDC Input 4 Channels and Output 2 Channels**

Analog mixed module IC200ALG432 provides four -10 to +10VDC analog inputs and two -10 to +10VDC analog outputs.

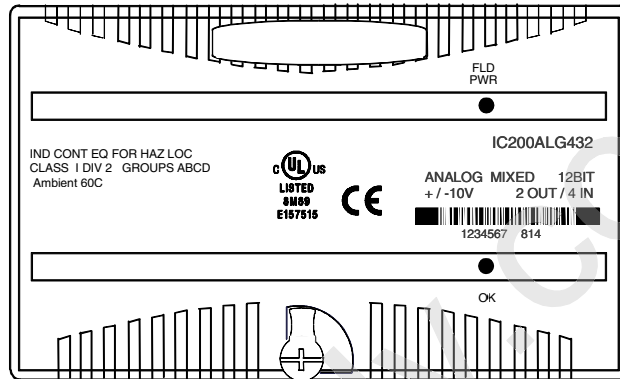

An external 24V power supply is required for the outputs. For inputs, power for the user's transceivers must be supplied from an external source. Intelligent processing for this module is performed by the CPU or Network Interface Unit. The module provides 4 words of analog input data and receives 2 words of analog output data.

LED Indicators

The green FLD PWR LED indicates the presence of user-side power for the analog field-side circuits.

The green OK LED is on when backplane power is present to the module.

Diagnostics

The module reports a Loss of User Side Power fault for field-side circuits.

I/O Defaults

The module is easily set up with a jumper for the outputs to either hold their last states or default to 0V if backplane power or communications are interrupted or the PLC is stopped. External user power must remain uninterrupted. Outputs remain in their default or last state until the module receives different output data from the backplane, or until field power is removed.

When software-configured, inputs can be configured to hold last state or report a selectable value. When the module is autoconfigured using a CPU or NIU that is version 2.x or later, inputs default to 0. If the CPU or NIU is version 1.5 or earlier, the input default matches the jumper-configured output default (0 or Hold Last State).

IC200ALG432

Analog Mixed Module, 12 Bit +/-10VDC Input 4 Channels and Output 2 Channels

Module Specifications

Module Characteristics	
Channels	4 single-ended inputs, one group, 2 single-ended outputs, one group
Module ID	FFFF9024
Isolation:	
User input to logic (optical) and to frame ground	250VAC continuous; 1500VAC for 1 minute
Group to group	Not applicable
Channel to channel	None
LED indicators	FLD PWR LED indicates field power is present OK LED indicates backplane power is present
Backplane current consumption	5V output: 60mA maximum
Thermal derating	None
Configuration parameters	Output default
Diagnostics	Loss of User Side Power
External Power Supply	
Recommended range	+18 to +30VDC (including ripple)
Current consumption at recommended range	160mA max.(including load current)
12V operation range	9.6 to 15VDC, 12VDC nominal (including ripple)
Current consumption at 12V range	175mA max.(including load current)
Input Characteristics	
Input voltage:	+/-10VDC
Input Impedance	125kOhms minimum
Accuracy at 25 degrees C*	+/-0.3% typ. of full scale, +/-0.5% max. of full scale
Accuracy at 0 to 60 degrees C	+/-1% maximum of full scale
Resolution:	2.5mV = 8 counts
Filter response	5.0ms
Update rate per module	0.4ms
Common mode voltage	0 V
Channel-to-channel crosstalk rejection	30dB minimum
Output Characteristics	
Output voltage	+/-10.24VDC
Load characteristics:	
Resistive	5000 Ohms minimum
Capacitive	1.0μF maximum
Accuracy at 25 degrees C*	+/- 0.3% typ. of full scale, +/- 0.5% max. of full scale
Accuracy at 0 to 60 degrees C	+/-1% maximum of full scale
Resolution	5mV = 16 counts
Update rate per module	0.3ms maximum
Channel-to-channel crosstalk rejection	70dB minimum
Output default	Hold Last State (default), 0 (configurable)

* In the presence of severe RF interference, (IEC 1000-4-3, 10V/m), accuracy may be degraded to +/-1%.

IC200ALG432
Analog Mixed Module, 12 Bit +/-10VDC Input 4 Channels and Output 2 Channels

Field Wiring

Terminal	Connection	Terminal	Connection
A1	V OUT 1	B1	No connection
A2	V OUT Return	B2	Shield Termination Point
A3	V OUT 2	B3	No connection
A4	V OUT Return	B4 <td Shield Termination Point	
A5	V IN 1	B5	No connection
A6	V IN Return	B6	Shield Termination Point
A7	V IN 2	B7	No connection
A8	V IN Return	B8	Shield Termination Point
A9	V IN 3	B9	No connection
A10	V IN Return	B10	Shield Termination Point
A11	V IN 4	B11	No connection
A12	V IN Return	B12	Shield Termination Point
A13	No connection	B13	JMP1A
A14	No connection	B14	JMP1B
A15	No connection	B15	No connection
A16	No connection	B16	No connection
A17	Field Return	B17	No connection
A18	Field Power	B18	No connection

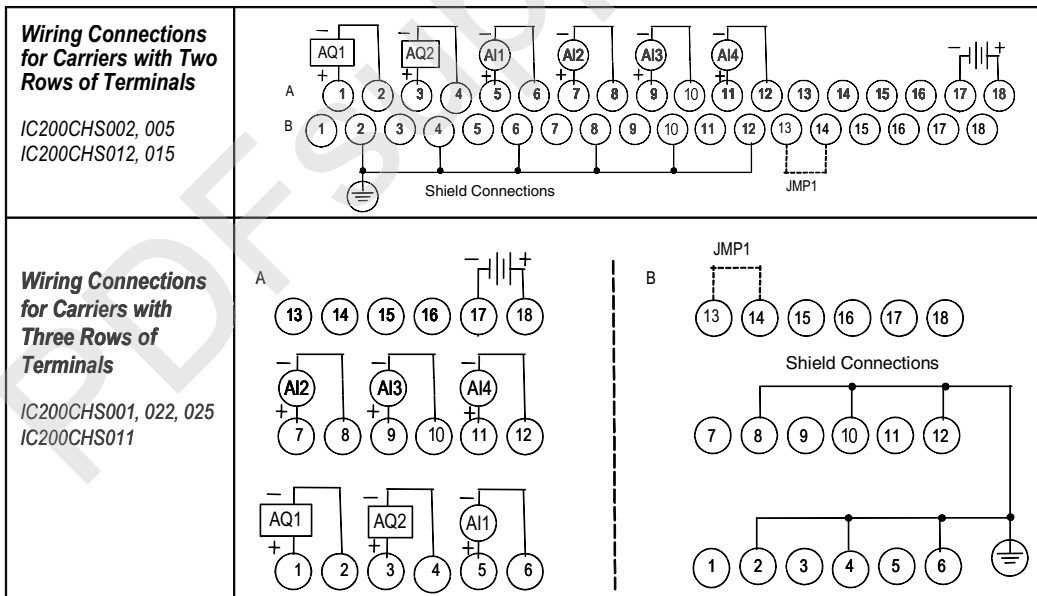

IC200ALG432

Analog Mixed Module, 12 Bit +/-10VDC Input 4 Channels and Output 2 Channels

Jumper Selection

If no jumper is installed outputs hold their last state (the last commanded value from the backplane) if backplane power or communications are interrupted or the PLC is stopped. With a jumper installed, if such conditions occur outputs default to 0V. This should only be changed with field power and backplane power removed.

Jumper	Default
None	Hold Last State
JMP 1	0V

Wiring Example

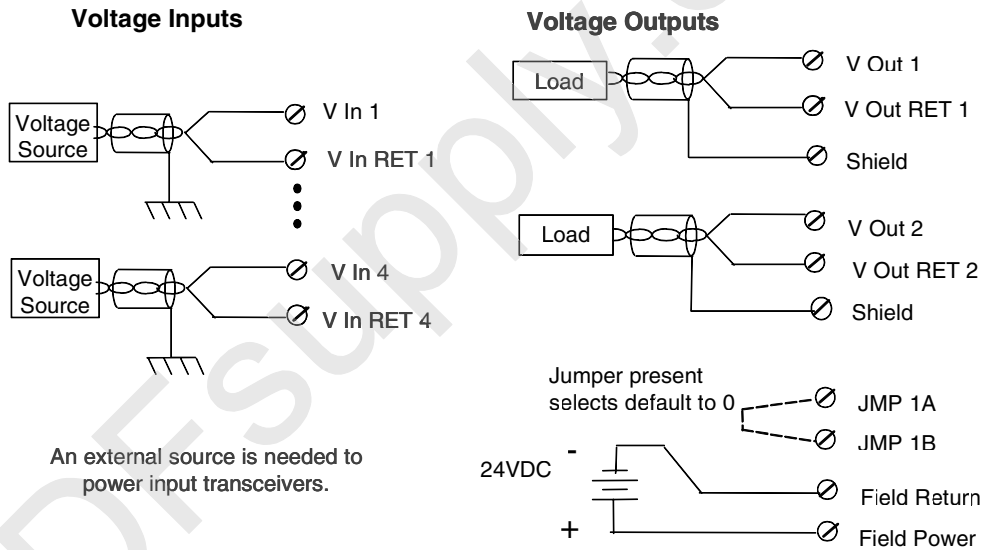

IC200ALG432
Analog Mixed Module, 12 Bit +/-10VDC Input 4 Channels and Output 2 Channels**Cable Shield Connections**

Shielded twisted pair cable is recommended for all of the analog channel connections. If possible, the analog input channel connections should be grounded at the source device. If that is not possible, the cable shield must be grounded at the I/O module.

If the module is installed on a Terminal-style I/O Carrier (IC200CHS001, 002, or 005) or a Compact Terminal-style I/O Carrier (IC200CHS022, 025), the cable shield can be connected directly to the carrier per the Field Wiring Table. An Auxiliary I/O Terminal Strip (IC200TBM001, 002, or 005) can also be added to the Terminal-style I/O Carriers to aid in grounding shields. Be sure to ground the Auxiliary I/O Terminal Strip as well if you plan to use it for this purpose.

If the module is installed on a Connector-style I/O Carrier (IC200CHS003), the cable shield can be connected directly to an Interposing Terminal (IC200CHS011, 012, 015). Be sure to ground the Interposing Terminal. It is recommended to use a shielded interposing cable as well between the Interposing Terminal and the Connector Base. A custom shielded cable can be made using the Connector kit (IC200ACC302). In addition, a custom shield braid can be wrapped around standard Interposing Cables (IC200CBL105, 110, 120, 230). If this approach is used be sure to ground the braid.

All cable shield connections should be connected to earth ground and be kept as short as practical. The power cable does not need to be shielded.

IC200ALG432

Analog Mixed Module, 12 Bit +/-10VDC Input 4 Channels and Output 2 Channels

Scaling

The following graphs show the relationship between the voltage applied at the field terminals and the data values for the module.

Count vs Input Voltage

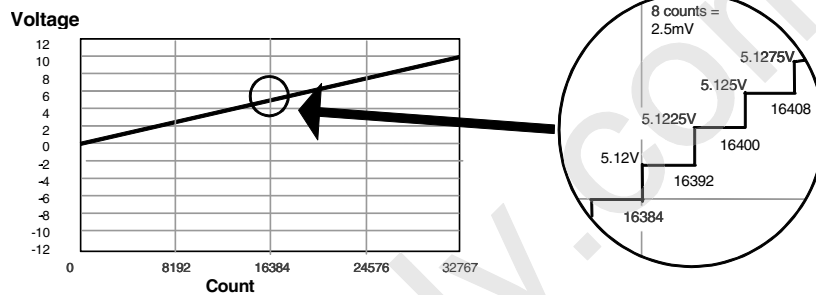

The following equation can be used to calculate counts values:

$$\text{Counts} = (\text{Voltage In}) \times (3200)$$

The count value is returned as a multiple of 8. A voltage that would return a count value (using the above equation) which is not a multiple of 8 will return the next highest multiple of 8.

Input Voltage	Count
5.1200	16384
5.1210	16392
5.1220	16392
5.1225	16392

IC200ALG432
Analog Mixed Module, 12 Bit +/-10VDC Input 4 Channels and Output 2 Channels

Count vs Output Voltage

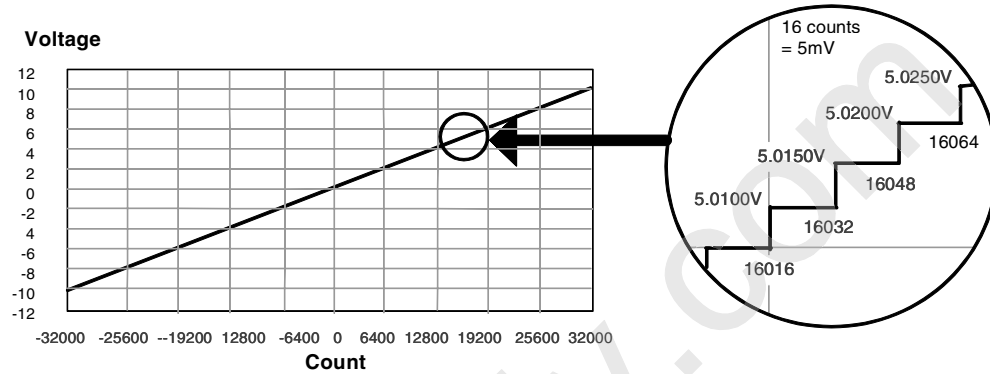

Voltage can be calculated using the following equation:

$$V_{out} = (\text{analog counts} \times 20.5) / 65535$$

The count value must be a multiple of 16. If the module receives a count value that is not a multiple of 16, it rounds the value down to the closest multiple of 16. For example:

Count	Voltage
16032	5.0150V
16040	5.0150V
16048	5.0200V