

IC600PM544
New In Stock!
GE Fanuc

<http://www.pdfsupply.com/automation/ge-fanuc/ge-series-six-6/IC600PM544>

Ge Series Six 6
1-919-535-3180

Redundant Processor Unit Auxiliary Power Supply, 24Vdc IC600P
IC600PM

www.pdfsupply.com

Email: sales@pdfsupply.com

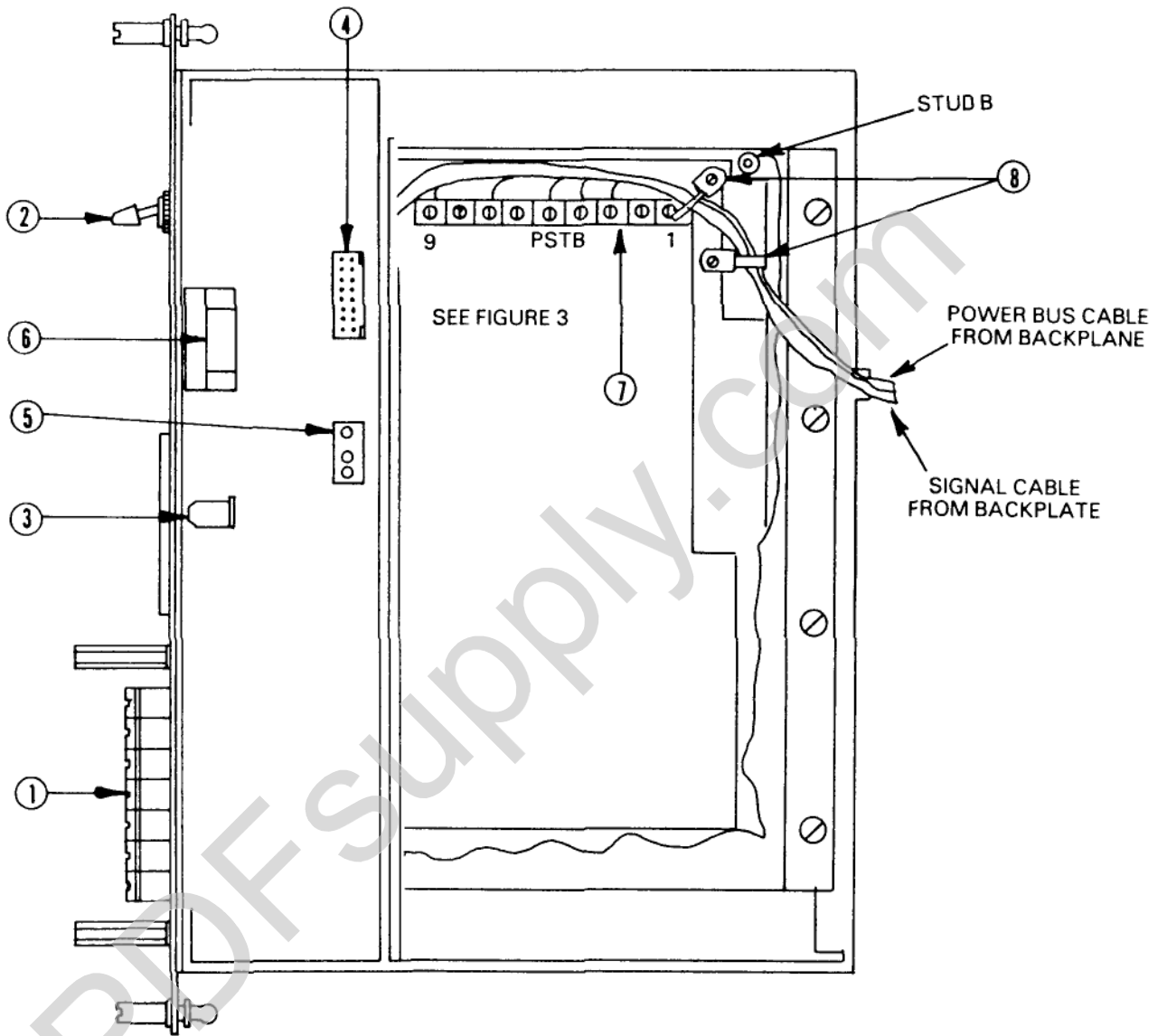

- ① Front Panel Connector Block
- ② Power Switch
- ③ Power-On LED

On: The voltage levels of both DC outputs (+12V and +5V) are within tolerance.

Off: At least one of these voltage levels is out of tolerance.

- ④ P1, 16-Pin Connector
- ⑤ P6, 3-Pin Connector
- ⑥ 8A Fuse
- ⑦ Power Supply Terminal Board
- ⑧ Cable Clamp

FIGURE 2. USER ITEMS

INSTALLATION

The RPU is designed to operate either with a single power supply module or with two power supply modules. The removal and replacement guidelines for a power supply module in a dual supply system can also apply to a single supply system.

When two power supply Modules are used the system offers power supply redundancy in such a way that:

- If both power supply modules are functioning normally one module has the load and the other is on standby.
- If one power supply module fails the other either continues to carry the load or automatically assumes it without affecting the normal operation of the RPU system.
- A power supply module should be able to be removed or installed while the RPU system is up and running without interrupting the normal operation of the RPU system.

However, because there may be 'live' voltages on a power supply module, even after the switch to that module is turned off, the following removal and replacement guidelines should be observed.

Auxiliary Power Supply Module Replacement (RPU running)

1. Switch RUN/HOLD switch to HOLD.
2. Remove power to failed power supply by disconnecting DC source.
3. Disconnect wiring to DC and alarm terminals.
4. Remove partition faceplate between power supplies.
5. Release quarter-turn fasteners and slide power supply out to expose connectors located behind faceplate.
6. Disconnect the 4 wires from the supply chassis and 2 connectors from the monitor circuit board.
7. Remove the failed power supply.
8. Reverse the above procedure to install the replacement module.
9. After the replacement power module has been installed apply power to module and verify that the POWER-ON LED is on.
10. Switch RUN/HOLD switch to RUN.

NOTE

Care should be taken to avoid shorting components or leads on the module being replaced. The free-hanging connectors from this module should also be handled or positioned in such a way that they not be brought into contact with conductive surfaces.

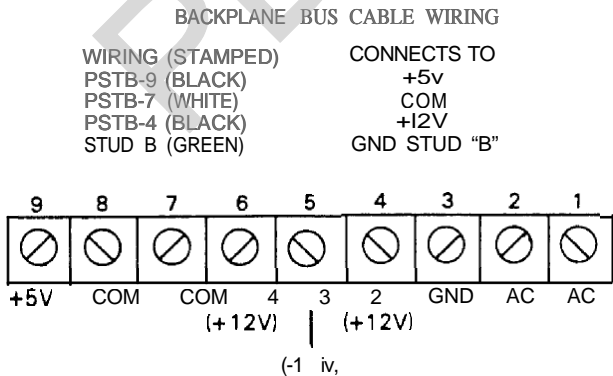

FIGURE 3. POWER SUPPLY TERMINAL BLOCK

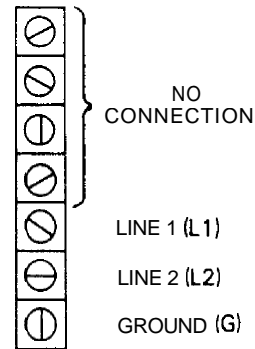

FIGURE 4. FRONT PANEL TERMINAL BLOCK

ORDERING INFORMATION

<u>Module</u>	<u>Catalog Number</u>
20 to 32 V dc Auxiliary Power Supply Module	IC600PM544A

CATALOG NUMBER REVISION SUFFIX

The equipment listed above having the catalog numbers shown and the same equipment having a higher alpha suffix is designed for listing by UL for use as auxiliary control devices. The equipment is a direct replacement for equipment having the same catalog number but a lower alpha suffix.



This symbol on the nameplate means the product is listed by Underwriters Laboratories Inc. (UL Standard No. 508, Industrial Control Equipment, subsection Electronic Power Conversion Equipment.)

For further information, contact your local GE Fanuc sales office.

GE Fanuc Automation North America, Inc., Charlottesville, Virginia