

**IC600PM548**

**New In Stock!**

**GE Fanuc**

<http://www.pdfsupply.com/automation/ge-fanuc/ge-series-six-6/IC600PM548>

**Ge Series Six 6**

**1-919-535-3180**

In Stock! High Capacity I/O Rack Power Supply, 125Vdc IC600P  
IC600PM

[www.pdfsupply.com](http://www.pdfsupply.com)

Email: [sales@pdfsupply.com](mailto:sales@pdfsupply.com)

Ref. PC-S6-84-0243

Ref. PC-S6-84-0244

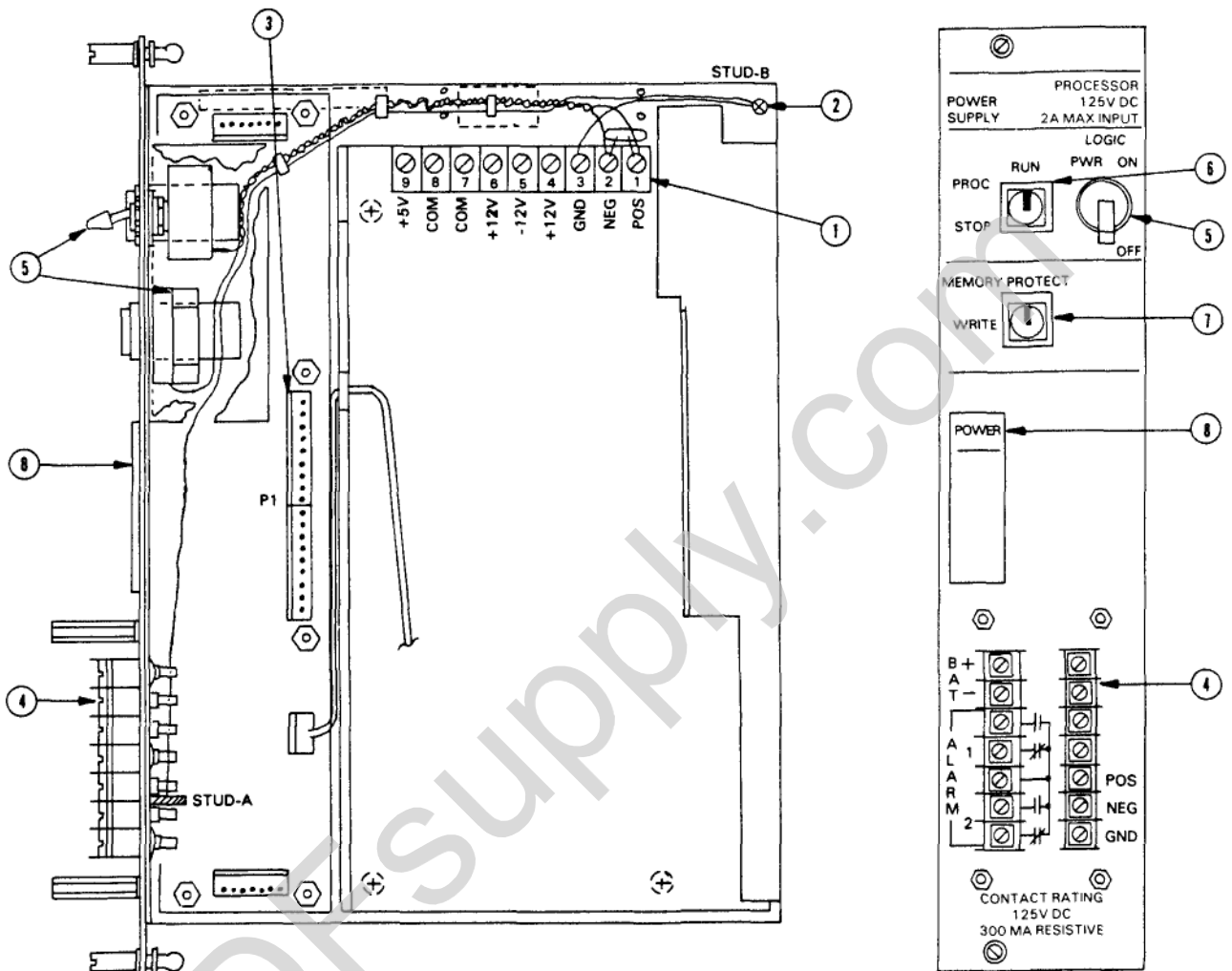

SIDE VIEW

FRONT PANEL

- 1 Internal Terminal Strip (Refer to Figure 2)
- 2 Chassis Ground Terminal
- 3 18-Pin Connector: Connects signal cable from rack backplane
- 4 Front-Panel Connector Block (Refer to Figure 3)
- 5 Power Switch/Fuse

- 6 CPU RUN/STOP Keyswitch
- 7 MEMORY PROTECT Keyswitch
- 8 POWER Light

On: The voltage levels of all three DC outputs (+12V, -12V, +5V) are within tolerance

Off: At least one of these voltage levels is too low

FIGURE 1. USER ITEMS

## INSTALLATION (Continued)

7. At the top and bottom of the power supply, there are 1/4-turn thumbscrews. To loosen, turn the thumbscrews approximately 1/4 turn counterclockwise.
8. Grasp the thumbscrews and gently pull outward. Be careful not to damage the internal wiring while pulling the supply out.
9. Locate the wires that extend from the back of the rack to the terminal on the power supply. These wires should be labeled or stamped with their location; the circuit boards have wire locations stamped on them. Remove these wires. There is also a plastic wire clamp holding these wires in place. Detach this from the frame if there is not a similar item on the replacement power supply, or cut the clamp if there is one on the new supply.  
  
Remove the 18-pin (P1) molex connector that is on the narrow board in the front part of the power supply. The power supply should now be completely detached from the rack.
10. Take the replacement power supply and attach the wires as shown in Figure 2. Be sure to connect the 18-pin molex connector (P1) to the power supply. Attach the wire clamp on the upper stud of the power supply frame, or if there is a clamp already there, wrap the wires in it.
11. Slide the power supply into the rack, being careful not to damage the wires. When the power supply is all the way in, turn the thumbscrews clockwise until they lock in.
12. Remove the plastic cover on the lower portion of the power supply and attach the DC wires, as well as the battery and alarm wires, as they were on the original supply (Refer to Step 6 and Figure 3). Replace the plastic cover.
13. Verify that the DC input lines are of the correct polarity before applying power. An inadvertent reversal of input polarity will cause the supply to draw excessive currents and may blow the internal fuse (2A slo-blow) which must then be replaced before proper operation can be resumed.
14. Restore system power. Turn on the CPU unit. Check to see if the POWER light is on. If it is, turn on the rest of the system and resume normal operation.
15. If the POWER light does not come on, the power supply may be bad, source voltage may not be turned on, or there may be other problems within the rack. Please call your local authorized GE Fanuc Automation Distributor or Sales office for assistance.

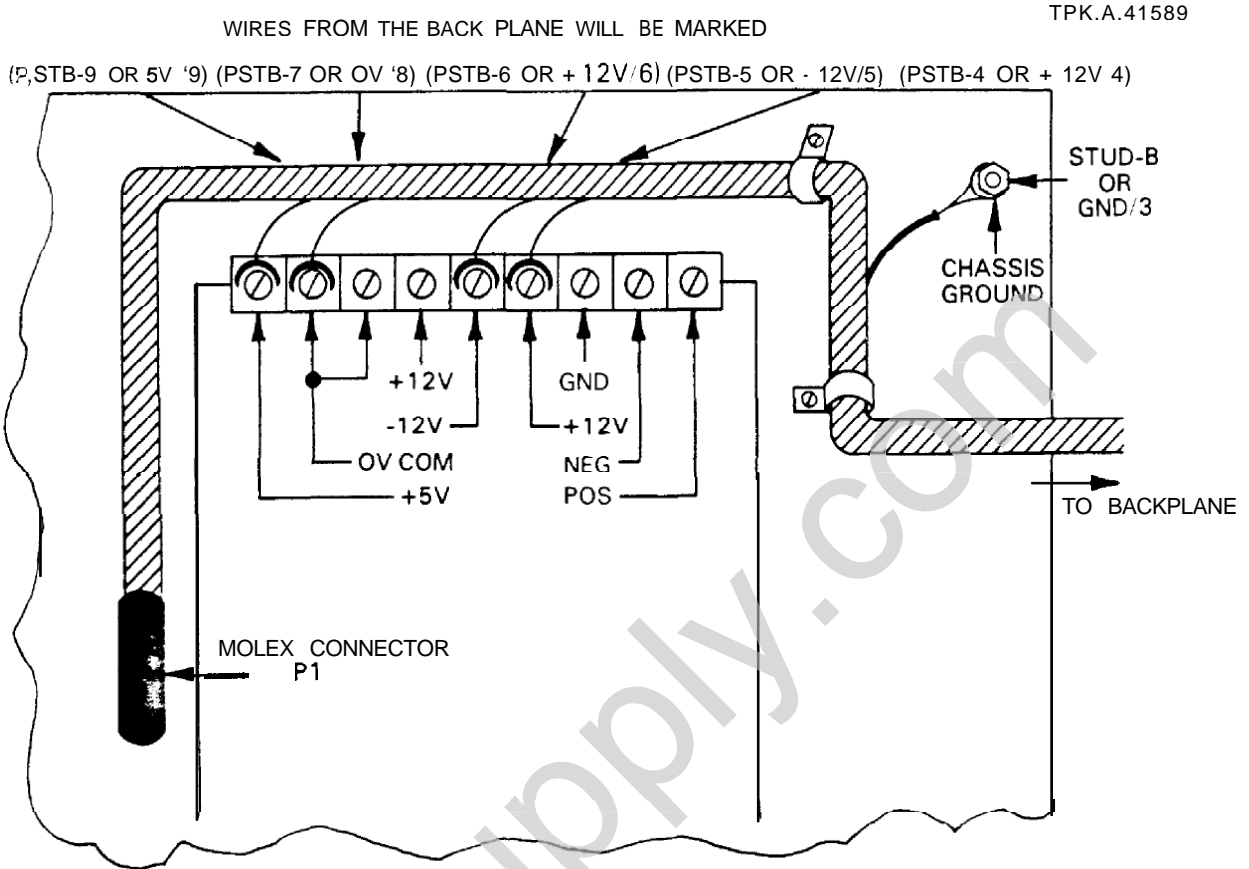

FIGURE 2. POWER SUPPLY EXTERNAL WIRING DIAGRAM

**CAUTION**

If a memory auxiliary battery is used, the circuit connecting it to this module should be isolated from the rest of the system. If this CAUTION is not observed, the battery could be short-circuited.

The alarm contacts consist of two sets of normally-opened and normally-closed contacts. The terminals marked "1 NO" and "1 NC" are associated with Alarm Type No. 1; the terminals marked "2 NO" and "2 NC" with Alarm type No. 2. (Refer to Series Six Plus User's Manual, GEK-96602, for further information on Alarm Nos. 1 and 2.)

**CAUTION**

The user devices connected to each set of Alarm terminals on this module should present a resistive load drawing no more than one amp of current at no greater than 115 V ac/28 V dc. Failure to observe this CAUTION may result in damage to the circuit board.

NOTE

During normal operation the alarm relays are energized. During an alarm condition the contacts marked 1NO and 2NO, open, and those marked 1NC and 2NC, close.

Ref. PC-S6-84-0246

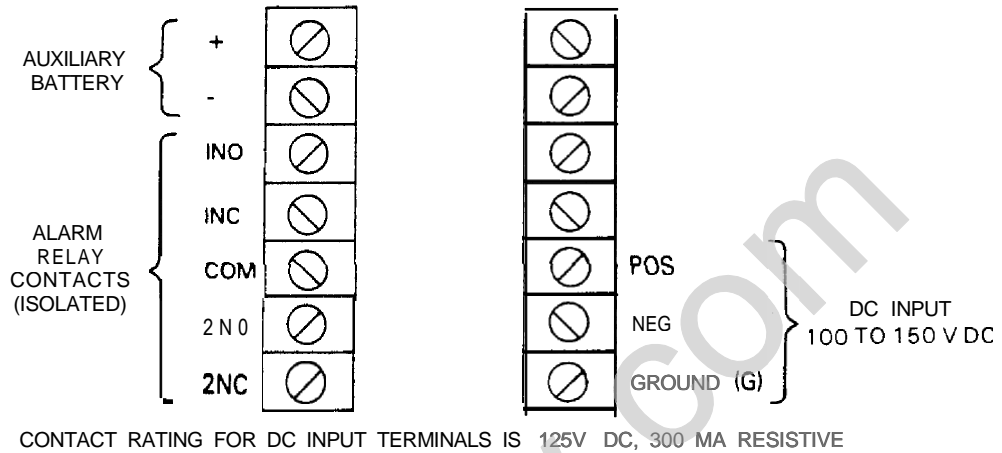

FIGURE 3. FRONT-PANEL TERMINAL BLOCK

**ORDERING INFORMATION**

Module	Part Number
125 V dc Input CPU Power Supply Module	IC600PM546

The UL symbol on the nameplate means the product is listed by Underwriters Laboratories Inc. (UL Standard No. 508, Industrial Control Equipment, subsection Electronic Power Conversion Equipment .)

For further information, contact your local GE Fanuc Automation Sales office.

**GE FANUC AUTOMATION NORTH AMERICA, INC., CHARLOTTESVILLE, VIRGINIA**

MARCH, 1987