

**IC600RB752**  
**New In Stock!**  
**GE Fanuc**

<http://www.pdfsupply.com/automation/ge-fanuc/ge-series-six-6/IC600RB752>

**Ge Series Six 6**  
**1-919-535-3180**

In Stock! RPU Device Switch Module IC600R IC600RB

[www.pdfsupply.com](http://www.pdfsupply.com)

Email: [sales@pdfsupply.com](mailto:sales@pdfsupply.com)

S6840139

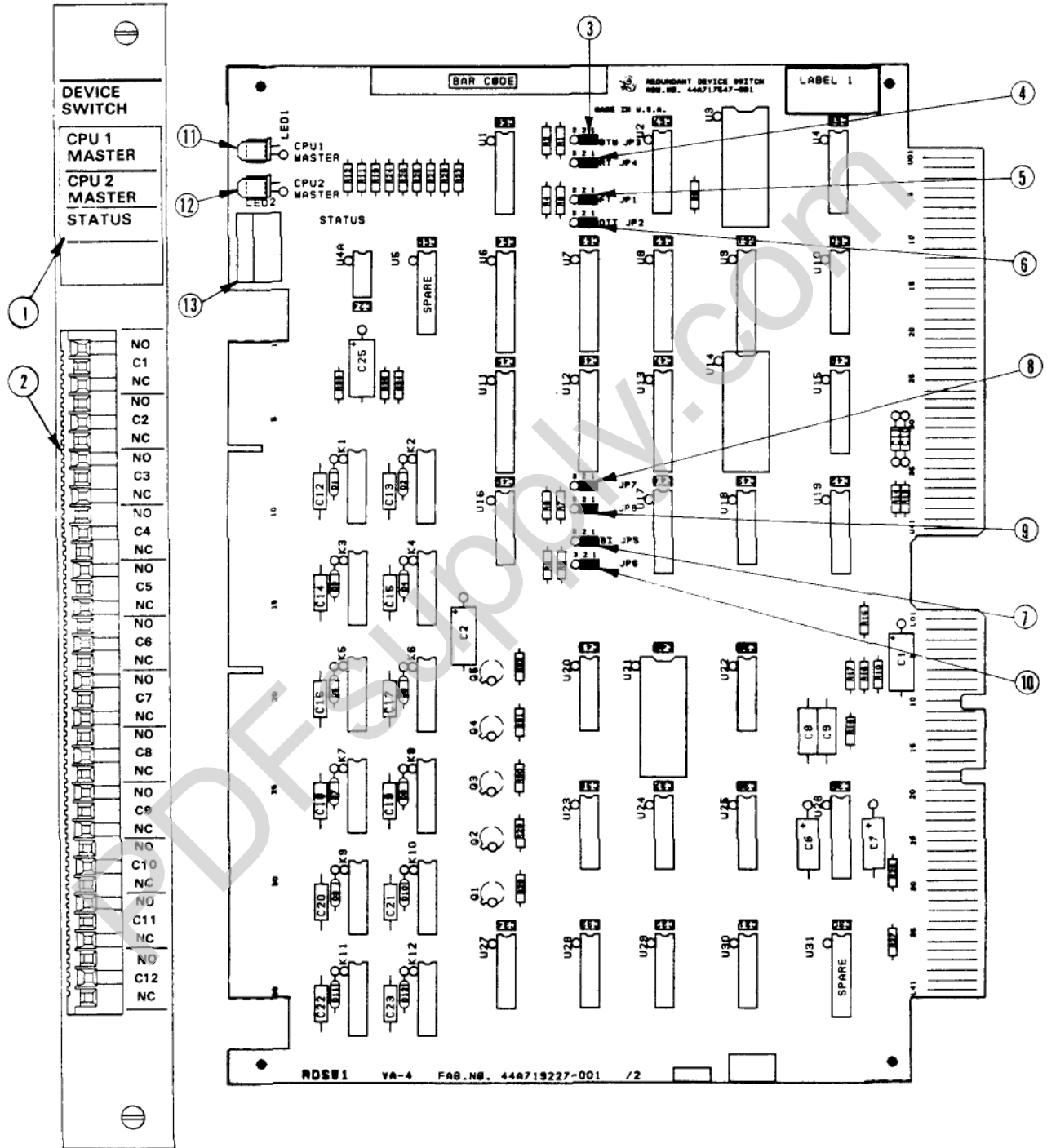

Figure 1. User Items

GEK-84863B

1. Faceplate
2. 36-point Connector
3. Jumper BT 3 2 1 (3 2 1 not active)  
Register 254 will be transferred from the Backup to the Master CPU each sweep.
4. Jumper RT 3 2 1 (3 2 1 not active)  
Allows specified registers to be transferred from the Master CPU to the Backup CPU each sweep. Start register value in R255, end register value in R256 of Master CPU.
5. Jumper FT 3 2 1  
Set at factory. Do not alter.
6. Jumper OTT 3 2 1 (3 2 1 not active)  
Output status table (Main I/O chain) and transition table will be transferred from the Master to Backup CPU each sweep.
7. Jumper BI 3 2 1  
The RPU will transfer up to 4096 registers, and all inputs, outputs, override and transition tables from the Master CPU to the Backup CPU whenever a CPU becomes a Backup. (From either off-line or Master status.)  
  
3 2 1  
  
The RPU will transfer only the data specified by the BTM, RT and OTT jumpers, in addition to the default transfers.
8. Jumper JP6  
3 2 1  
Enables 11024 to be used as Backup Bit in Backup CPU.  
  
3 2 1  
  
If your system uses PT4 I/O transmitter board(s), you will have to set RDSW board switch JP6 to the 1,2 position from the factory 2,3 position to move the Backup Bit to 11022.
9. Jumper JP7 Not used

10. Jumper JP8

3 2 1

Selects 150ms maximum scan time. Compatible with ALU2 and ALU3 CPU Arithmetic Logic Units.

3 2 1

Selects 250ms maximum scan time. Compatible only with ALU3 boards in both CPUs.

NOTE

These data transfer options may also be selected by certain Master CPU table bits. Input status table and timer time base values are always transferred from Master CPU to backup CPU each sweep. Data transfer options selected will impact Master and Backup CPU sweep time.

11. Status Display LED CPU1

When on, indicates that CPU1 is selected to be the Master CPU.

12. Status Display LED CPU2

When on, indicates that CPU2 is selected to be the Master CPU.

STATUS, seven segment LED display

- 0 - Single I/O - No Aux. I/O
- 1 - Redundant I/O - No Aux. I/O           NORMAL
- 2 - Single I/O and Aux. I/O           OPERATION
- 3 - Redundant I/O and Aux. I/O
- 4 - Hung I/O Bus
- 5 - Data Storage Card Failure
- 6 - Data PROM Card Failure           RPU
- 7 - Data Control Card Failure       ERRORS
- 8 - Device Switch Card Failure
- 9 - CPU Switch Card Failure

NOTE

A flashing display indicates that the watchdog timer has timed out. (RUN/HOLD switch in "HOLD" position, processor failure, or any of errors 5-9 displayed).

Figure 1. User Items (Cont'd)

### Installation

Set the option jumpers as described in Figure 2. Install the Device Switch Module in the eighth slot from the left of the RPU, using the extraction/insertion tool supplied with the RPU to seat it firmly in place.

**CAUTION**

**The module may be installed or removed under power, but the RPU RUN/HOLD switch on the Main Power Supply must be in the HOLD position, or damage to the equipment may result. Replacement of the Device Switch under power almost always results in system shut down, even in Hold Mode.**

Before installing the faceplate, make any required connections to the 36 point connector attached to the faceplate. Connections include, but are not limited to:

- Sharing a CRT or printer between a Master or Backup CPU (see Figure 2).

- Sharing a communications line set up to an external Host computer, or modem between a Master and Backup CPU Communications Control Module.
- Sharing an external analog device between two D/A or A/D cards located in the Master and Backup I/O chains.

The 12 device relays are Form C. The NO (normally open), NC (normally closed), and C (common) contacts for each relay are labeled on the faceplate. For example, relay 1 is labeled as NO, NC and C1, relay 2 is labeled NO, NC and C2, and so on.

The C contact of each relay is made to its NC contact whenever the RPU bus position is CPU1. Conversely, the C contact of each relay is made to its NO contact whenever the RPU bus position is CPU2. See Table 2 for the relay contact specifications.

After all required connections have been made, guide the faceplate into position on the module, then secure the faceplate to the rack by tightening the thumb-screws at the top and bottom.

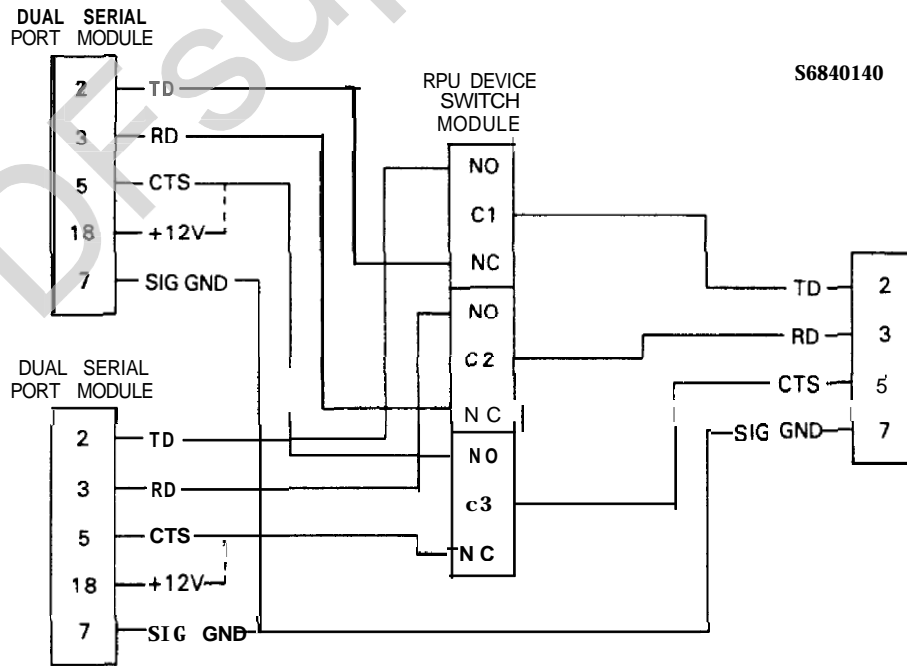

Figure 2. Peripheral Connections

Printer, CRT, etc. Connections

\*Serial port CTS must be jumped to +12 V if the user device does not provide a CTS signal.

---

GEK-84863B

**Table 3. Ordering Information**

<b>Circuit Board</b>	<b>Circuit Board and Faceplate</b>	<b>Faceplate</b>
IC600RB752	IC600BF752	IC600FPI752

The UL symbol on the nameplate means the product is listed by Underwriters Laboratories Inc. (UL Standard No. 508, Industrial Control Equipment, subsection Electronic Power Conversion Equipment.)

For further information, contact your local GE Fanuc sales representative.

PDFSupply.com