

# Chapter 22

## 8 Point Isolated Analog Voltage-Source Output Module IC670ALG310

The 8 Point Isolated Analog Voltage-source Output Module (IC670ALG310) accommodates eight voltage outputs in two isolated groups of four. It provides eight channels of analog voltage outputs with user-configurable scaling for each channel.

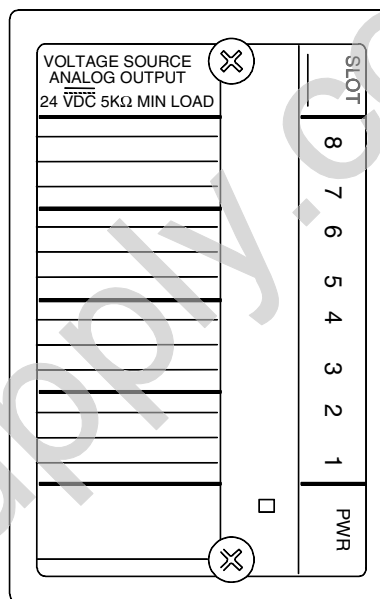

- Supports 8 channels of output voltages ranging from -10V to +10V with 14-bit resolution.
- Output overrange provided for up to approximately 10.25V.
- Uses both word and bit data types.
- Can be field-recalibrated or reset to factory calibration. Calibration data stored in FLASH memory.
- Individual channel configuration including output range and scaling parameters.
- Reports Under/Overage faults.

### Power Sources

The 8 Point Isolated Analog Voltage-source Output Module requires a separate source of power for the outputs.

### LEDs

A single indicator shows module status:

- ON: normal operation
- Intermittent flashing: module fault
- OFF: No backplane power, no user power, or fatal fault.

### Module Operation

During operation, the module receives engineering units output data from the Bus Interface Unit (BIU). It scales this data according to its calibration and configured scaling parameters, then converts the data to output voltage in the range of -10V to +10V.

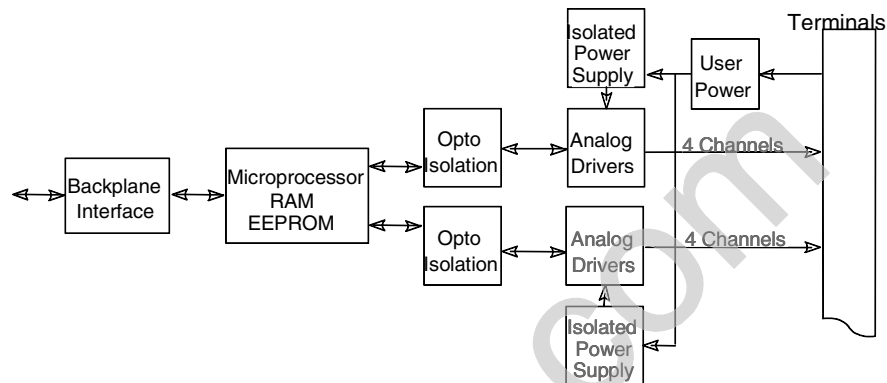

The 8 Point Isolated Analog Voltage-source Output Module provides the following alarms:

- **Over/Underrange:** if an engineering units value sent by the host has resulted in an output value within approximately 50mV of the module's maximum or minimum.
- **Loss of User Power**
- **Uncalibrated Module**

If an alarm occurs, the module sets a bit in its optional discrete input data. These alarm bits can be monitored by the application logic. They can be reset by sending appropriate alarm-clearing discrete output data to the module.

### Host Interface

The 8 Point Isolated Analog Voltage-source Output Module uses the following types of data:

- 0-8 words of analog output data
- 0-3 bytes of discrete input data for module and channel status.
- 0-2 bytes of discrete output data for clearing alarms.

The module exchanges data with a Bus Interface Unit in the same manner as other types of I/O modules—it provides all its input data and status bits when requested by the BIU, and receives fault-clearing commands and analog output data from the BIU.

The module can also be configured for “Group” data transfer with the BIU or with other intelligent devices in the same Field Control station. Group data is described in the *Bus Interface Unit User's Manual*.

### Compatibility

This module must be used with a Bus Interface Unit revision 2.0 or later.

## 8 Point Isolated Analog Voltage-Source Output Module

**Module Configuration Overview**

Like other Field Control modules, the 8 Point Isolated Analog Voltage-source Output Module is usually configured from the Bus Interface Unit, using a compatible hand-held programmer. The module's configuration can also be read or written from the bus in a system which supports such configuration. The table below summarizes configuration choices and defaults. The module will power up with the default configuration settings. For configuration instructions, refer to the *Bus Interface Unit User's Manual*.

Module Parameter	Description	Default	Choices
<b>Analog Output Data Length</b>	Length in words for the module's analog output data in the BIU's analog output (AQ) table.	8 words	0-8
<b>Analog Output Reference</b>	Starting offset for the module's analog output data in the BIU's analog output (AQ) table.		User selected
<b>Discrete Input Data Length</b>	Length in bits for the module's optional discrete input diagnostic data in the BIU's discrete input (I) table.	24 bits	0, 8, 16, 24
<b>Discrete Input Reference</b>	Starting offset for the module's diagnostic data in the BIU's discrete input (I) table.		User selected
<b>Discrete Output Data Length</b>	Length in bits of the module's optional discrete output fault clearing data in the BIU's discrete output (Q) table.	16 bits	0, 8, 16
<b>Discrete Output Reference</b>	Starting offset for the module's fault clearing data in the BIU's discrete output (Q) table.		User selected
<b>(BIU) Defaults: Input data</b>	If the BIU loses communications with the module, the module's discrete input (diagnostic) data can be set to zero or hold its last state.	Zero	Zero, Hold Last State
<b>(BIU) Defaults: Output data</b>	If the BIU loses communications with the network, the module's discrete (fault clearing) and analog output data can be set to zero or hold its last state.	Zero	Zero, Hold Last State
<b>Local Defaults: Outputs</b>	If a reset or local failure occurs, the module can set the actual outputs to zero or hold their last values (this requires local power).	Zero	Zero, Hold Last State
<b>Channel Active</b>	Whether a channel will respond to commanded analog and discrete output data and return alarms. If a channel is inactive its output is zero. If a previously-active channel is reconfigured as inactive, any pre-existing alarms can still be cleared using Q data.	Active	Inactive, Active
<b>Range</b>	There are two preset scaling ranges. +/-10V (bipolar) range: span and engineering units from +/-10,000. 0 to 10V (unipolar) range: span and engineering units from 0 to 10,000.	+/- 10V	+/-10V, 0 to 10V
<b>Span Low</b>	Actual voltage in millivolts to be scaled to low engineering units.	-10,000	-16,384 to +16,383
<b>Span High</b>	Actual voltage in millivolts to be scaled to high engineering units.	+10,000	
<b>Engineering Low</b>	Engineering units equivalent of the low span value.	-10,000	
<b>Engineering High</b>	Engineering units equivalent of the high span value.	+10,000	

### **Module Features**

#### **Channel Active**

Each channel can be configured as either active or inactive.

If a channel is Inactive, its output is 0V and the analog output data for the channel is not used. Alarm (optional discrete input) data for the channel is not updated for a channel that has been configured as Inactive.

If the configuration of a channel is changed from Active to Inactive, the module stops updating its alarm data. Pre-existing alarms can still be cleared using the module's configured discrete output bits.

#### **Local Output Defaults**

In addition to being able to configure data defaults of zero or hold last state for the module's data in the BIU, local output defaults for the module are also configurable. These module local defaults determine whether the module will set the actual output voltages to zero volts or hold their last values if a module error occurs.

#### **Hold Last State**

If the output default of a channel is Hold Last State and user power is present, the channel output holds its last value if:

1. The BIU resets the module.
2. No output data is received from the BIU within the BIU Timeout period.
3. Backplane power is lost.
4. The module's watchdog timer expires.

Outputs will continue to hold their last states until the module receives output data from the BIU or until user power is removed.

## 8 Point Isolated Analog Voltage-Source Output Module

**Scaling**

Scaling defines the constant-slope mapping from the value in engineering units sent by the BIU to a channel's output voltage. There are two preset scaling ranges: +/-10 volts and 0 to 10 volts.

The default range selection of +/-10 volts is for bipolar scaling. Both the span and engineering units can range from -10,000 to +10,000 millivolts.

The other preset range, 0 to +10 volts is for unipolar scaling, gives both span and engineering units of 0 to +10,000 millivolts.

The illustration below represents the two preset ranges.

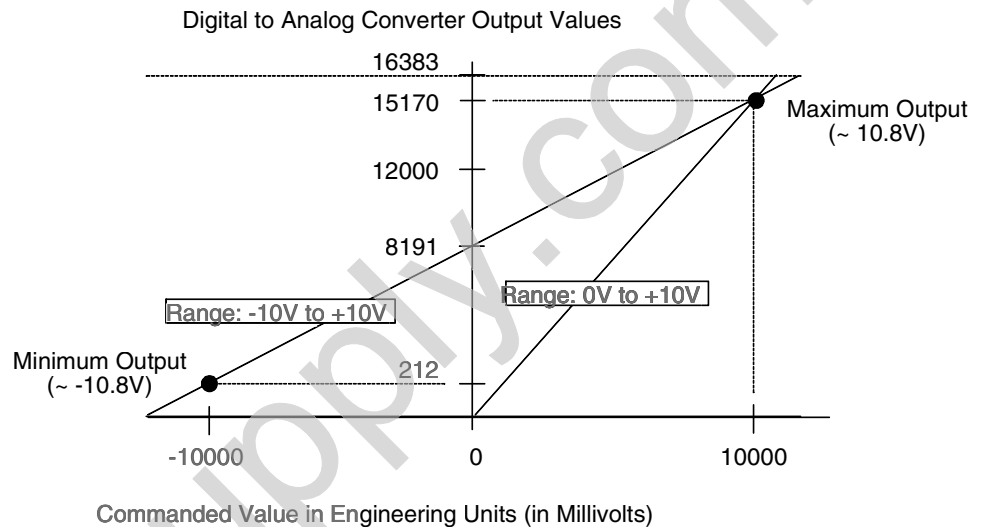

After selecting either the bipolar or unipolar range (see above), scaling for each point can be customized by changing its high or low engineering units and/or output (span) values.

The scaling values selected do not restrict the hardware output range.

**Module Specifications**

<b>Module Characteristics</b>	
Number of channels (single ended)	8
Power supply range (see note 1)	18 to 30 VDC, 24 VDC typical. 5% maximum ripple
Operating temperature range	0 to 55 degrees C ambient
Isolation to ground and logic	1500 VAC peak for 1 minute, 250 VAC continuous
Current Drawn from BIU power supply	170 mA maximum
Current Drawn from external power supply	275 mA maximum at 18V, all outputs -10V into minimum load
<b>Output Characteristics</b>	
Resolution	14 bits
Magnitude data size	14 bits
Accuracy (see note): at 25deg. C from 0 to +55 deg. C	0.15% of full scale (maximum) 0.25% of full scale (maximum)
Output Range Limits:	-10.25V to +10.25V
Analog resolution	~ mV per count, maximum resolution
Output load capacitance	1 $\mu$ F maximum
User Load	5000 Ohms minimum
Update time	1.5 mS typical

**note:** In the presence of severe RF interference (IEC 801-3, 10V/m), accuracy may be degraded to  $\pm$  2% tolerance.

**Keying Locations**

Optional keying locations for the 8 Point Isolated Analog Voltage-source Output Module are:

<b>Keying Locations</b>									
A	B	C	D	E	F	G	H	J	K
x			x					x	x

8 Point Isolated Analog Voltage-Source Output Module

**Field Wiring**

Instrumentation grade Shielded Twisted Pair wire should be used for best noise immunity. The shield should be terminated at a local panel ground near the module. The following illustration shows typical connections for this module.

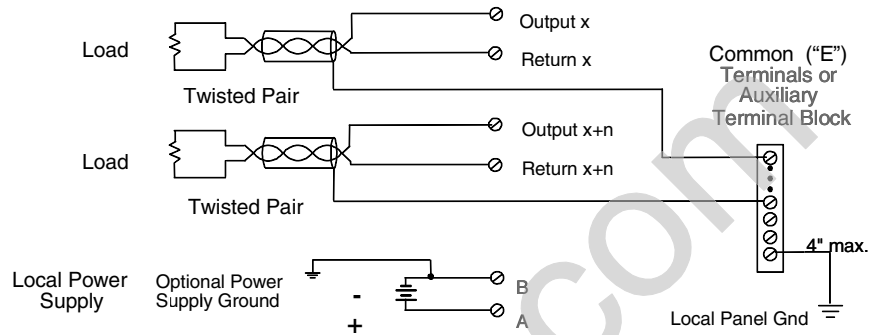

An Auxiliary Terminal Block can be used to provide additional wiring terminals for the shields. Auxiliary Terminal Blocks have all terminals connected together internally. The Auxiliary Terminal Block with box terminals (IC670TBM002) has 13 terminals; each accommodates one AWG #14 (avg 2.1mm<sup>2</sup> cross section) to AWG #22 (avg 0.36mm<sup>2</sup> cross section) wire. The Auxiliary Terminal Block with barrier terminals (IC670TBM001) has nine terminals; each can accommodate one or two wires up to AWG #14 (avg 2.1mm<sup>2</sup> cross section).

**I/O Terminal Block Terminal Assignments**

An Terminal Block with Box Terminals has 25 terminals per module. Each accommodates one AWG #14 (avg 2.1mm<sup>2</sup> cross section) to AWG #22 (avg 0.36mm<sup>2</sup> cross section) wire, or two wires up to AWG #18 (avg. 0.86mm<sup>2</sup> cross section). If an external jumper is used, single-wire capacity is reduced from AWG #14 (2.10mm<sup>2</sup>) to AWG #16 (1.32mm<sup>2</sup>).

An I/O Terminal Block with Barrier Terminals has 18 terminals per module. Each terminal can accommodate one or two wires up to AWG #14 (avg 2.1mm<sup>2</sup> cross section).

An I/O Terminal Block with Connectors has one 20-pin male connector per module.

All Return terminals are common to each other.

I/O Terminal Block with Box Terminals (IC670CHS002 or 102)	I/O Terminal Block with Barrier Terminals (IC670CHS001 or 101)	I/O Terminal Block with Wire to Board Connectors (IC670CHS003 or 103)																																																																																																												
<table border="0"> <tr><td>Return B</td><td>16</td><td>Return B</td></tr> <tr><td>Output B4</td><td>14</td><td>Output B3</td></tr> <tr><td>Common</td><td>E8</td><td>Output B1</td></tr> <tr><td>Output B2</td><td>12</td><td>Return B</td></tr> <tr><td>Return B</td><td>10</td><td>Return A</td></tr> <tr><td>Common</td><td>E6</td><td>Output A4</td></tr> <tr><td>Return A</td><td>8</td><td>Output A3</td></tr> <tr><td>Output A4</td><td>6</td><td>Return A</td></tr> <tr><td>Common</td><td>E4</td><td>Output A2</td></tr> <tr><td>Output A2</td><td>4</td><td>Return A</td></tr> <tr><td>Return A</td><td>2</td><td>Output A1</td></tr> <tr><td>Common</td><td>E2</td><td>Return A</td></tr> <tr><td>User Return</td><td>B2</td><td>Common</td></tr> <tr><td>User Return</td><td>B1</td><td>+24V nominal</td></tr> <tr><td></td><td>A1</td><td>+24V nominal</td></tr> </table> <p>Terminals E1, E2, E4, E6, and E8 are electrically connected together, A1 and A2 are electrically connected together, B1 and B2 are electrically connected together.</p>	Return B	16	Return B	Output B4	14	Output B3	Common	E8	Output B1	Output B2	12	Return B	Return B	10	Return A	Common	E6	Output A4	Return A	8	Output A3	Output A4	6	Return A	Common	E4	Output A2	Output A2	4	Return A	Return A	2	Output A1	Common	E2	Return A	User Return	B2	Common	User Return	B1	+24V nominal		A1	+24V nominal	<table border="0"> <tr><td>Return B</td><td>16</td><td>Return B</td></tr> <tr><td>Output B4</td><td>14</td><td>Output B3</td></tr> <tr><td>Output B2</td><td>12</td><td>Output B1</td></tr> <tr><td>Return B</td><td>10</td><td>Return B</td></tr> <tr><td>Return A</td><td>8</td><td>Return A</td></tr> <tr><td>Output A4</td><td>6</td><td>Return A</td></tr> <tr><td>Output A2</td><td>4</td><td>Output A3</td></tr> <tr><td>Return A</td><td>2</td><td>Output A1</td></tr> <tr><td>User Return</td><td>B</td><td>Return A</td></tr> <tr><td></td><td>A</td><td>+24V nominal</td></tr> </table>	Return B	16	Return B	Output B4	14	Output B3	Output B2	12	Output B1	Return B	10	Return B	Return A	8	Return A	Output A4	6	Return A	Output A2	4	Output A3	Return A	2	Output A1	User Return	B	Return A		A	+24V nominal	<table border="0"> <tr><td>Output B1</td><td>11</td><td>Return B</td></tr> <tr><td>Output B2</td><td>12</td><td>Return B</td></tr> <tr><td>Output B3</td><td>13</td><td>Return A</td></tr> <tr><td>Output B4</td><td>14</td><td>Return A</td></tr> <tr><td>Return B</td><td>15</td><td>Return A</td></tr> <tr><td>Return B</td><td>16</td><td>Output A4</td></tr> <tr><td>Return B</td><td>17</td><td>Output A3</td></tr> <tr><td>+24V nominal</td><td>A2</td><td>Output A2</td></tr> <tr><td>+24V nominal</td><td>A1</td><td>Output A1</td></tr> <tr><td>User Return</td><td>B2</td><td>Return A</td></tr> <tr><td>User Return</td><td>B1</td><td>Return A</td></tr> </table>	Output B1	11	Return B	Output B2	12	Return B	Output B3	13	Return A	Output B4	14	Return A	Return B	15	Return A	Return B	16	Output A4	Return B	17	Output A3	+24V nominal	A2	Output A2	+24V nominal	A1	Output A1	User Return	B2	Return A	User Return	B1	Return A
Return B	16	Return B																																																																																																												
Output B4	14	Output B3																																																																																																												
Common	E8	Output B1																																																																																																												
Output B2	12	Return B																																																																																																												
Return B	10	Return A																																																																																																												
Common	E6	Output A4																																																																																																												
Return A	8	Output A3																																																																																																												
Output A4	6	Return A																																																																																																												
Common	E4	Output A2																																																																																																												
Output A2	4	Return A																																																																																																												
Return A	2	Output A1																																																																																																												
Common	E2	Return A																																																																																																												
User Return	B2	Common																																																																																																												
User Return	B1	+24V nominal																																																																																																												
	A1	+24V nominal																																																																																																												
Return B	16	Return B																																																																																																												
Output B4	14	Output B3																																																																																																												
Output B2	12	Output B1																																																																																																												
Return B	10	Return B																																																																																																												
Return A	8	Return A																																																																																																												
Output A4	6	Return A																																																																																																												
Output A2	4	Output A3																																																																																																												
Return A	2	Output A1																																																																																																												
User Return	B	Return A																																																																																																												
	A	+24V nominal																																																																																																												
Output B1	11	Return B																																																																																																												
Output B2	12	Return B																																																																																																												
Output B3	13	Return A																																																																																																												
Output B4	14	Return A																																																																																																												
Return B	15	Return A																																																																																																												
Return B	16	Output A4																																																																																																												
Return B	17	Output A3																																																																																																												
+24V nominal	A2	Output A2																																																																																																												
+24V nominal	A1	Output A1																																																																																																												
User Return	B2	Return A																																																																																																												
User Return	B1	Return A																																																																																																												

### Diagnostics Data

The 8 Point Isolated Analog Voltage-source Output Module performs diagnostics and provides 24 bits (3 bytes) of diagnostic data to the BIU. Data is placed in the BIU's discrete input (I) data table starting at the configured reference. The module sets the appropriate bit of this data when a diagnostic condition is detected. Diagnostics bits remain set until cleared by the appropriate data outputs, as described below. The condition causing the fault must be corrected, or the module will set the bit again. Use of this data is optional. The module is easily configured to use all, some, or none of the diagnostic data.

Module Diagnostics Bits (byte 0)

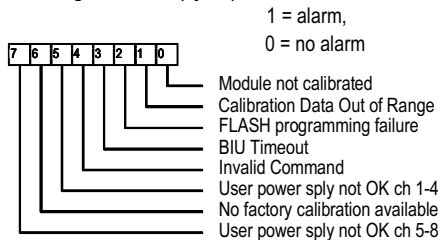

Channel Under/Overrange Bits (byte 2)

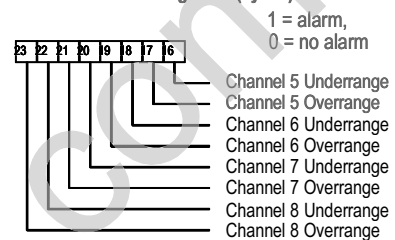

Channel Under/Overrange Bits (byte 1)

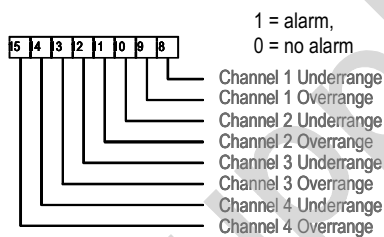

### Clearing Faults and Alarms

The BIU uses two bytes of discrete output data to clear the module fault and alarm bits. The fault-clearing bits start at the module's configured discrete output reference in the BIU's discrete output (Q) table. Setting a bit in the first byte of discrete output data to 1 clears the over/underrange alarms for the corresponding channel (even if the alarm conditions are still present).

Bits #0-2, 4, and 6 in the module diagnostics byte are calibration-related and should never be set during normal operation. These bits cannot be cleared using discrete output (Q) data. If any of these bits is set during normal operation (not during calibration), a problem exists and the module should be returned.

Output Command Bits to Clear Alarms (byte 0)

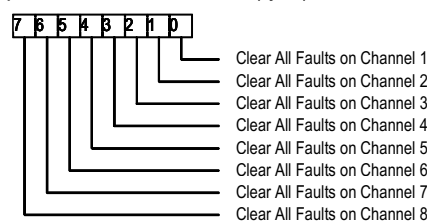

byte 1

