

## 24 VDC Positive/Negative Logic, 32 Point Input IC693MDL653

This **24 volt DC Positive/Negative Logic Input** module for the Series 90-30 Programmable Logic Controller provides 32 input points in four isolated groups with eight points in each group. Each group has two common pins associated with it, which are tied together internally. The On and Off response times for this module are 2 milliseconds maximum. This input module is designed to have both positive and negative logic characteristics. When connected for positive logic, it sinks current from the input device to the user common or negative power bus. The input device is connected between the positive power bus and the circuit input. When connected for negative logic, it sources current through the input device to the user common or positive power bus. The input device is connected between the negative power bus and the circuit input. Current into an input point results in a logic 1 in the input status table (%I).

Input characteristics are compatible with a wide range of input devices, such as pushbuttons, limit switches, and electronic proximity switches. Power to operate field devices must be supplied by the user.

Connections to the input circuits are made from the user's input devices to a 50-pin connector mounted on the front of the module. Prewired cables having a mating connector on one end and the wires on the opposite end terminated with terminal lugs are available from GE Fanuc.

This module does not have LED indicators to indicate circuit status. This module can be installed in any I/O slot of a 5 or 10-slot baseplate in a Series 90-30 PLC system.

**Table 6-10. Specification for IC693MDL653**

<b>Rated Voltage</b>	24 volts DC
<b>Input Voltage Range</b>	24 volts DC (+10%, -20%)
<b>Inputs per Module†</b>	32 (four groups with two commons per group)
<b>Isolation</b>	1500 volts between field side and logic side
<b>Input Current</b>	7.5 mA (average) at rated voltage
<b>Input Characteristics</b>	
<b>On-state Voltage</b>	15 volts DC minimum
<b>Off-state Voltage</b>	6 volts DC maximum
<b>On-state Current</b>	4.5 mA minimum
<b>Off-state Current</b>	2 mA maximum
<b>On response Time</b>	2 ms maximum
<b>Off response Time</b>	2 ms maximum
<b>Internal Power Consumption</b>	5 mA (16 inputs on) from 5 volt bus on the backplane

† The maximum number of inputs turned on at the same time should be limited to 16 or less.  
Refer to data sheet GFK-0867C, or later revision for product standards and general specifications.

## IC693MDL653 Input Module Field Wiring Information

The following figure provides wiring information for connecting user supplied input devices and power source to the 24 volt DC positive/negative logic, FAST input module.

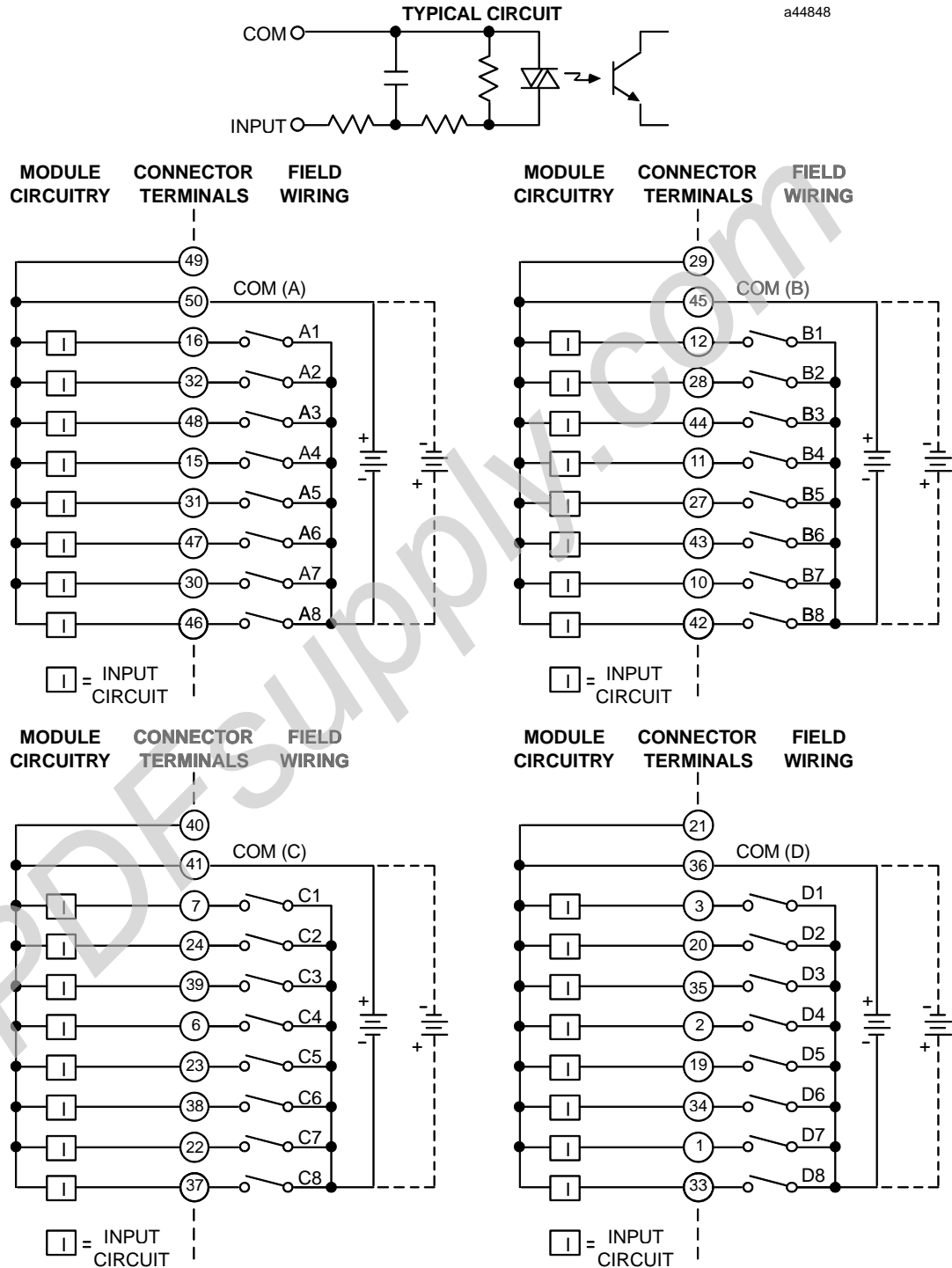

**Figure 6-16. Field Wiring - 24 Volt Pos/Neg Logic 32 Point Input Module - IC693MDL653**