

# PLC Racks

## Standard Racks - Front and Rear Mount

GFK-0079K  
November 1999

Five Slot, Rear Mount - IC697CHS750  
Nine Slot, Rear Mount - IC697CHS790  
Nine Slot, Front Mount - IC697CHS791

### Features

- Accepts all IC697 PLC module types
- Rear mount racks mount in a 10" (254 mm) deep enclosure (fans normally not required)
- Front mount rack mounts in a standard 19" (480 mm) rack (fans normally not required)
- Accepts plug-in AC or DC IC697 power supply
- Provision for two rack operation from single power supply

NOTE: For Power Supply compatibility see page 5.

### Functions

The Standard Nine-Slot Racks and the Five-Slot Rack for the IC697 programmable controller are used for all

CPU and I/O configurations. Each rack has provision for one power supply at the leftmost module position; and either nine additional slot locations (nine-slot rack) or five additional slot locations (five-slot rack).

Overall rack dimensions are 11.15" H x 19" W x 7.5" D (283mm x 483mm x 190mm) for the Nine-Slot Rack and 11.15" H x 13" W x 7.5" D (283mm x 320mm x 190mm) for the Five-Slot Rack. Slots are 1.6" wide except the power supply slot which is 2.4" wide.

Two racks can be interconnected to share a single power supply for applications having extended I/O requirements. A Power Supply Extension Cable kit (IC697CBL700) is available for such applications.

Each rack provides slot sensing for rack-type I/O modules designed for the IC697 PLC. No jumpers or DIP switches on the I/O modules are required for module addressing.

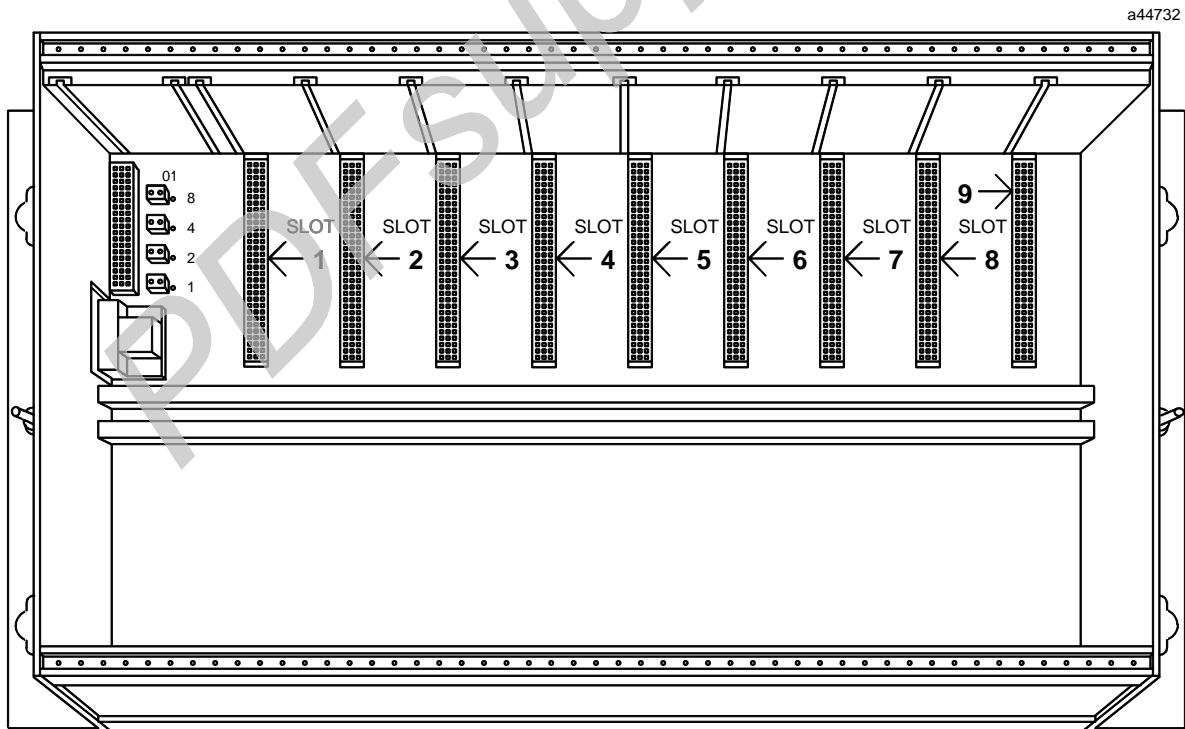

GFK-0079K  
November 1999

Five Slot, Rear Mount - IC697CHS750  
Nine Slot, Rear Mount - IC697CHS790  
Nine Slot, Front Mount - IC697CHS791

Rack Outline Drawings

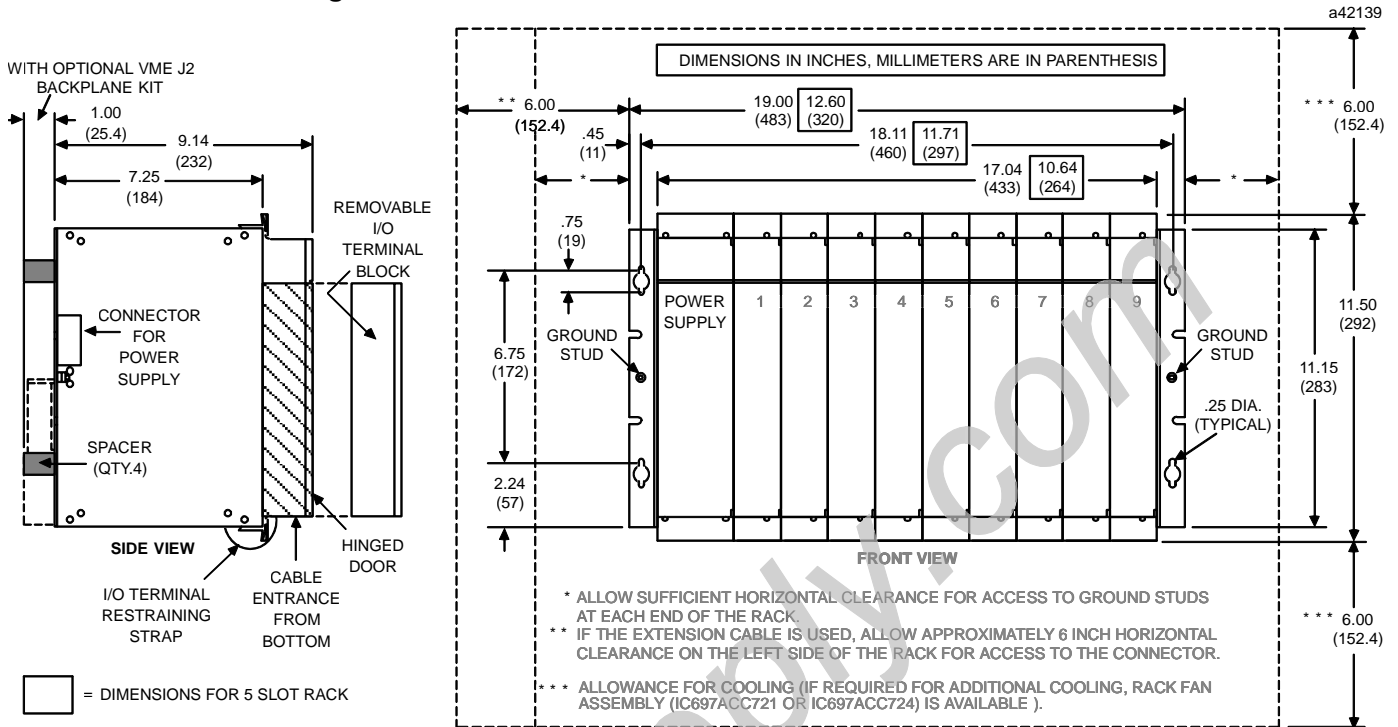

Figure 1. Outline Drawing for Standard Rear (Panel) Mount Rack

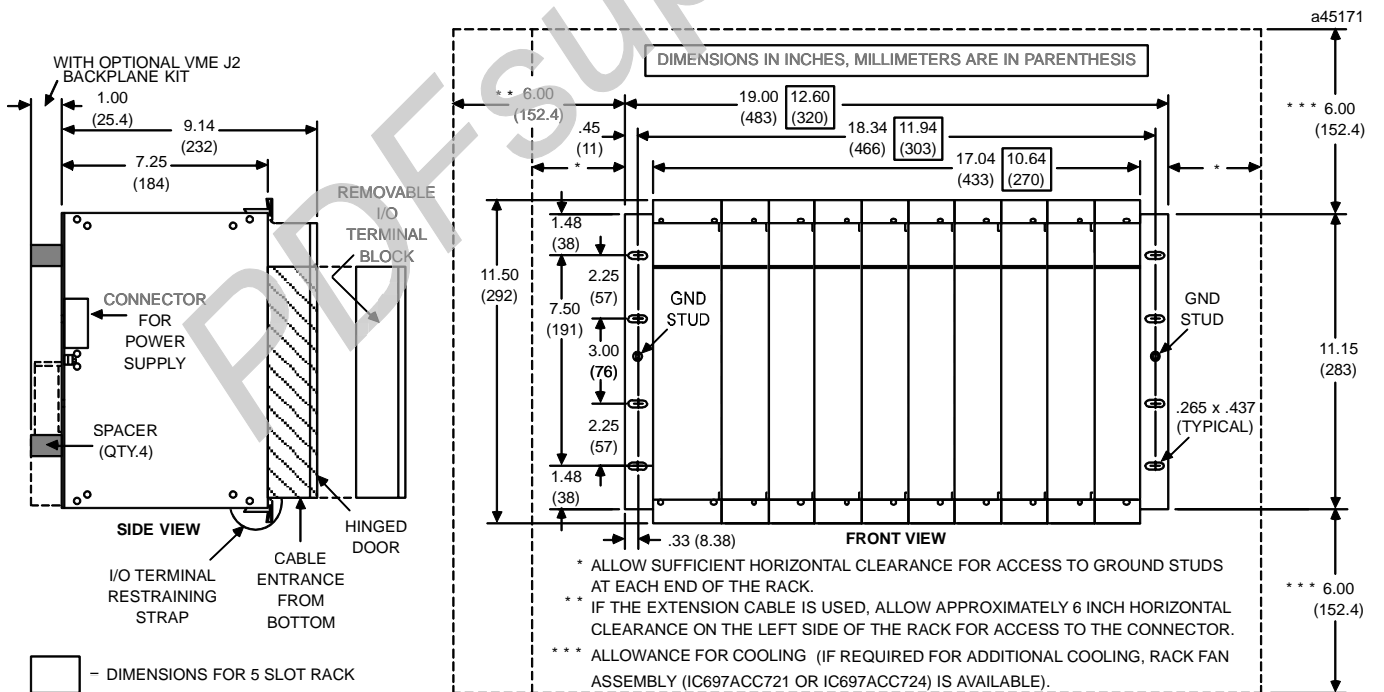

Figure 2. Outline Drawing for Standard Front (Rack) Mount Rack

Five Slot, Rear Mount - IC697CHS750  
Nine Slot, Rear Mount - IC697CHS790  
Nine Slot, Front Mount - IC697CHS791

GFK-0079K  
November 1999

## Rack Mounting

The rack must be mounted in the orientation as shown in Figures 1 and 2. Sufficient space must be left around the rack as shown to allow air flow for module cooling. The mounting requirements (either front or rear mount) must be determined according to the application and the proper rack ordered. Mounting flanges are an integral part of rack side panels and are installed at the factory.

A Rack Fan Assembly is available for mounting on the Nine-Slot Racks when required for installations where heat buildup could be a problem. The Rack Fan Assembly is available in three versions:

- IC697ACC721 for 120 VAC power source
- IC697ACC724 for 240 VAC power source
- IC697ACC744 for 24 VDC power source

Refer to GFK-0637C, or later for detailed information about the Rack Fan Assembly.

## I/O Connector

These racks accommodate rack-type IC697 high-density I/O modules, which use a detachable field wiring terminal board. Each I/O module will accept up to forty AWG #14 (2.10mm<sup>2</sup>) wires. The wire bundle is routed out the bottom of the terminal board cavity where a cleat is provided for a tie wrap to secure the bundle to the terminal board housing.

## Mechanical Keying

IC697 I/O modules are mechanically interlocked by means of a key to prevent inadvertent interchange of one module type for another (for example, AC type for DC type). A key unique to each module type is included with the module.

When the module is inserted into the rack, the key automatically latches onto the center rail of the rack, where it remains when the module is extracted. Only the correct module type can then be inserted into that rack slot.

If it is necessary to change the module location in the rack after the key has been latched onto the center rail of the rack, the key can be removed by pushing it upward to unhook the latch while pulling it off the rail. It may then be reinserted onto the module and the module inserted into the rack in the desired location.

## Note

The power supply slot is unique - only the power supply can be installed in the left-most rack position.

## Power Supply Extension Cable

For many applications, one power supply can provide the power requirements of two racks. Such dual-rack operation from a single power supply can be implemented if only 5 volt power of 5.2 amperes or less is required in the second rack.

A 3-foot (1 meter) Power Supply Extension Cable is available (see the Ordering Information on the last page of this data sheet) which provides the necessary interconnection. In addition to +5 volt power, the extension cable includes power sequencing signals necessary for proper system operation.

The Power Supply Extension cable attaches to a 9-pin D type connector located on the backplane. Access to the connector is via a hole in the left side of the rack as shown in the outline drawing. Adequate clearance (approximately 6 inches 152.4mm) must be provided on the left side of the rack for access to the connector.

The Power Supply Extension cable must be secured before power is applied. It must not be disconnected during system operation.

## Slot Addressing

The IC697 PLC system allows user configuration of I/O point references for modules in a rack without the need for board address DIP switches or jumpers. The address structure is described in the applicable *Programmable Controller Installation Manual*. Configuration is done with the MS-DOS® or Windows® programming software configurator function. For more information on configuration, see the applicable *Programming Software User's Manual*.

## Rack Number

Multiple racks in a system must be assigned a rack number from 0 to 7; the CPU rack is always Rack 0. The PLC determines the number of each rack in the system from four binary-encoded jumpers on the rack's backplane. These jumpers are located on the backplane directly behind the power supply, which must be removed to gain access to the jumpers.

GFK-0079K  
November 1999

Five Slot, Rear Mount - IC697CHS750  
Nine Slot, Rear Mount - IC697CHS790  
Nine Slot, Front Mount - IC697CHS791

© MS-DOS and Windows are registered trademarks of Microsoft Corporation.

To set the rack number, move the jumpers corresponding to 1, 2, 4, and 8 bits to either the 0 or 1 position. The sum of the digits in the 1 position equals the desired rack number. For example, rack number 2 would have the 1, 4 and 8 bit jumpers in the 0 position and the 2 bit jumper in the 1 position as shown below.

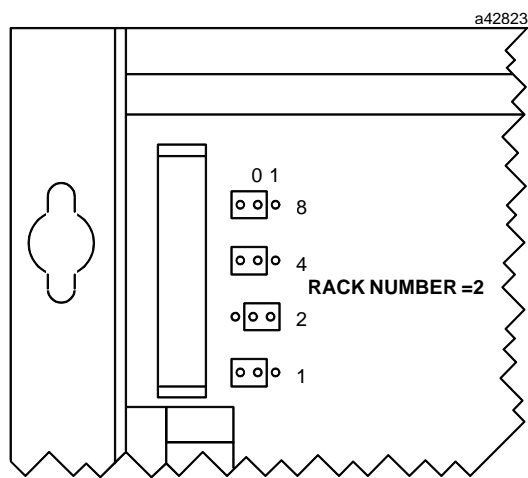

Figure 3. Rack Number Jumpers

## Safety Ground

The ground lug on either side of the rack must be connected to earth ground with not less than an AWG #12 (3.33mm<sup>2</sup>) wire. The ground lugs are #8-32.

### Warning

If the ground lug is not connected to earth ground, the rack is not grounded. The rack must be grounded to minimize electrical shock hazard which may result in severe personal injury.

## Shield Ground

The bottom rail of the rack is used for module shield grounding. Some IC697 I/O modules have a ground clip that contacts the conductive bottom rail when the module is fully inserted. Shield connections in the user connectors are routed to this ground clip via conductors on the module.

## System Noise Immunity

Three easy steps must be taken to properly ground the IC697 programmable controller system to reduce the possibility of errors due to electrical noise.

1. Make sure that the power supply mounting screws, especially the bottom two, are properly secured.
2. The GND terminal on the power supply must be connected to the GND terminal on either side of the rack using AWG #12 (3.33 mm<sup>2</sup>) wire. Use of a ring terminal and star washer is recommended.
3. The GND terminal on the rack must be connected to a good earth ground.

## Module Retention

IC697 I/O modules have molded latches that automatically snap onto the upper and lower rails of the rack when the module is fully inserted. Optionally, M2.5x8 screws may be used to secure the modules to the rack for high vibration applications.

### Warning

Do not remove (or insert) modules when either the programmable controller power supply or any externally-connected power sources are on. Hazardous voltages may exist. Personal injury, damage to the module or improper operation of the device or process being controlled may result.

To remove an IC697 module, first remove the field half of the terminal board (if it is an I/O module), then grasp the top and bottom of the module to depress the latch releases while pulling the module out. For more detailed information on removing I/O terminal boards, refer to the applicable *Programmable Controller User's manual* or individual data sheets for I/O modules.

If M2.5x8 screws have been used to secure modules to the rack, remove the screws before removing the modules.

A blank faceplate is available to cover unused slots in the rack. See the Ordering Information on page 5.

Five Slot, Rear Mount - IC697CHS750  
 Nine Slot, Rear Mount - IC697CHS790  
 Nine Slot, Front Mount - IC697CHS791

GFK-0079K  
 November 1999

Table 1. Specifications for Standard Racks, IC697CHS750/790/791 †

<b>Number of Slots</b>	5 or 9, plus power supply slot		
<b>Maximum 5 Volt Current</b>	20 amps (100 watt 120/240 VAC or 125 VDC power supply) 11 amps (55 watt 120/240 VAC or 125 VDC power supply) 18 amps (90 watt 24 VDC power supply) 18 amps (90 watt 48 VDC power supply)		
<b>Current Required from I/O Bus</b>	0.5 amps		
<b>I/O References</b>	User configurable without the use of module jumpers or DIP switches.		
<b>Rack Identification</b>	Four jumpers behind rack power supply		
<b>Dimensions</b>	<i>Height</i>	<i>Width</i>	<i>Depth</i>
<b>Nine Slot Rack</b>	11.15"	19.00"	7.5"
	283mm	483mm	190mm
<b>Five Slot Rack</b>	11.15"	12.6"	7.5"
	283mm	320mm	190mm
	All modules for the IC697 I/O system extend 1.7" (43mm) beyond the front of the rack.		
<b>VME</b>	System designed to support the VME standard C.1		

† Refer to GFK-0867B, or later for product standards and general specifications.

Table 2. Ordering Information

Description	Catalog Number
Rack , Five-Slot, rear mount	IC697CHS750
Rack, Nine-Slot, rear mount	IC697CHS790
Rack , Nine-Slot, front mount	IC697CHS791
Power Supply Cable Kit (includes cable and faceplate for vacant power supply slot)	IC697CBL700
Blank Faceplate Slot Filler (quantity 6)	IC697ACC720
Rack Fan Assembly, 120 VAC (optional)	IC697ACC721
Rack Fan Assembly, 240 VAC (optional)	IC697ACC724
Rack Fan Assembly, 24 VDC (optional)	IC697ACC744

Note: For Conformal Coat option, Low Temperature Testing option, or Severe Vibration option please consult the factory for price and availability. Racks for use in Severe Vibration environments include heavy duty side mount plates.

### Power Supply Compatibility With Rack Versions

The IC697 standalone power supplies can only be mounted on the IC697 racks having the catalog numbers listed below.

- IC697CHS790D (Nine-Slot, rear mount) and IC697CHS750C (Five-Slot, rear mount)

The catalog numbers for the standalone power supplies affected by this restriction are:

- IC697PWR721 (24 VDC, 90W Power Supply with Power Supply Adapter)
- IC697PWR722 (24 VDC, 90W Power Supply Module)
- IC697PWR731 (125 VDC, 60W Power Supply with Power Supply Adapter)
- IC697PWR732 (125 VDC, 60W Power Supply Module)

All plug-in IC697 power supplies can be installed in any version of the IC697 racks.

PDFsupply.com