



GE Fanuc Automation

Programmable Control Products

IC697VAL301
32-Channel 12-bit Analog Output Board with Built-in-Test (BIT)

User's Manual

GFK-2058

514-000436-000 A

December 2001

Warnings, Cautions, and Notes as Used in this Publication

Warning

Warning notices are used in this publication to emphasize that hazardous voltages, currents, temperatures, or other conditions that could cause personal injury exist in this equipment or may be associated with its use.

In situations where inattention could cause either personal injury or damage to equipment, a Warning notice is used.

Caution

Caution notices are used where equipment might be damaged if care is not taken.

Note

Notes merely call attention to information that is especially significant to understanding and operating the equipment.

This document is based on information available at the time of its publication. While efforts have been made to be accurate, the information contained herein does not purport to cover all details or variations in hardware or software, nor to provide for every possible contingency in connection with installation, operation, or maintenance. Features may be described herein which are not present in all hardware and software systems. GE Fanuc Automation assumes no obligation of notice to holders of this document with respect to changes subsequently made.

GE Fanuc Automation makes no representation or warranty, expressed, implied, or statutory with respect to, and assumes no responsibility for the accuracy, completeness, sufficiency, or usefulness of the information contained herein. No warranties of merchantability or fitness for purpose shall apply.

The following are trademarks of GE Fanuc Automation North America, Inc.

Alarm Master	Genius	PROMACRO	Series Six
CIMPLICITY	Helpmate	PowerMotion	Series Three
CIMPLICITY 90-ADS	Logicmaster	PowerTRAC	VersaMax
CIMSTAR	Modelmaster	Series 90	VersaPro
Field Control	Motion Mate	Series Five	VuMaster
GENet	ProLoop	Series One	Workmaster

Contents

Chapter 1	Introduction, Description, and Specifications	1-1
	Reference Material and Other GE Fanuc Manuals.....	1-1
	General Description	1-2
	Functional Description	1-3
	Safety Summary	1-4
Chapter 2	Configuration and Installation.....	2-1
	Physical Installation	2-2
	Before Applying Power: Checklist	2-3
	Base Address Configuration.....	2-4
	Calibration.....	2-9
	Connector Descriptions	2-13
Chapter 3	Programming.....	3-1
	Introduction to Controlling the Analog Output Board	3-2
	Control and Status Register Descriptions.....	3-3
	Initialization	3-4
	Controlling the Analog Outputs	3-8
	Testing the Analog Output Channels (BIT)	3-9
	Program Example.....	3-13
Chapter 4	Theory of Operation	4-1
	Internal Functional Organization	4-2
	VMEbus Interface	4-3
	Analog Outputs	4-6
	Analog Output Buffers and Switches.....	4-8
	Data RAM and Refresh Logic.....	4-9
	Built-in-Test (BIT) Multiplexers and ADC Logic	4-12
	Built-in Power Converter	4-14
Chapter 5	Maintenance.....	5-1

Chapter 1

Introduction, Description, and Specifications

This manual describes the installation and operation of the IC697VAL301 32-Channel 12-bit Analog Output Board with Built-in-Test (BIT).

Reference Material and Other GE Fanuc Manuals

For a detailed explanation of the VMEbus and its characteristics, “The VMEbus Specification” is available from:

VITA
VMEbus International Trade Association
7825 East Gelding Dr., No. 104
Scottsdale, AZ 85260
(480) 951-8866
FAX: (480) 951-0720
Internet: www.vita.com

The following Application and Configuration Guides are available from GE Fanuc to assist in the selection, specification, and implementation of systems based upon GE Fanuc’s products:

Analog I/O Products (Built-in-Test) Configuration Guide (catalog number GFK-2084)	Provides assistance in configuring analog I/O subsystems based on GE Fanuc’s analog I/O products, including common designs, which offer a wide variety of solutions.
Connector and I/O Cable Application Guide (catalog number GFK-2085)	Describes I/O connections that can be used with GE Fanuc’s VMEbus products. Includes connector compatibility information and examples.

General Description

The 32-Channel 12-bit Analog Output (AO) Board, with the Built-in-Test (BIT), features outputs that can be tested on-line or off-line with an on-board Analog-to-Digital Converter (ADC). This self-contained testing feature means this board does not require any special backplanes or analog input boards to test it. BIT permits verification of all active components by routing the analog outputs through analog input multiplexers to the on-board ADC.

The 32 analog outputs can supply 10 mA of drive current over the full output range of ± 10 V. Each output has a Sample-and-Hold buffer (S&H), and are protected from shorts and transients. The outputs can be unipolar or bipolar in jumper-selectable ranges up to ± 10 V. Each channel has an output switch which disconnects the buffer from the field. The output switches do not compromise the board's accuracy (output impedance is 0.1 Ω). When the board is powered-up or after a system reset, these switches are open and the buffers are disconnected from the field. The switches are under software control and can be opened or closed at any time.

A brief overview of the principal features of this board illustrates the flexibility and the performance that is available with the Analog Output Board:

- 32 analog output channels with 10 mA drive capability.
- Resident 12-bit ADC and DAC.
- Output ranges are jumper-selectable as 0 to +5 V, 0 to +10 V, ± 2.5 V, ± 5 V, ± 10 V.
- Output accuracy is 0.05 percent.
- Program-controlled off-line operation of analog outputs.
- BIT input data format is programmable as either binary, offset binary, or two's complement.
- Outputs are protected against line transients and short circuits.
- Front-panel user LED.
- Double height Eurocard form factor.
- Individually coded/keyed front panel VME DIN connector.
- Extended ground pin bus connectors.

Functional Description

The analog outputs on this board will supply up to 10 mA of drive current, and can be operated off-line for both loopback testing and for single-point analog output applications. Built-in-Test of all active components is provided by looping back the analog outputs with multiplexers and switches. These circuits are used to check either the on-line or the off-line analog outputs. The outputs support several operating voltage ranges. The range is selected by the user via jumpers. The scan rate is program controlled, and can be increased to provide an improved response for complex output functions. Figure 1-1 below is a block diagram of the board.

Figure 1-1: Analog Output Board Block Diagram

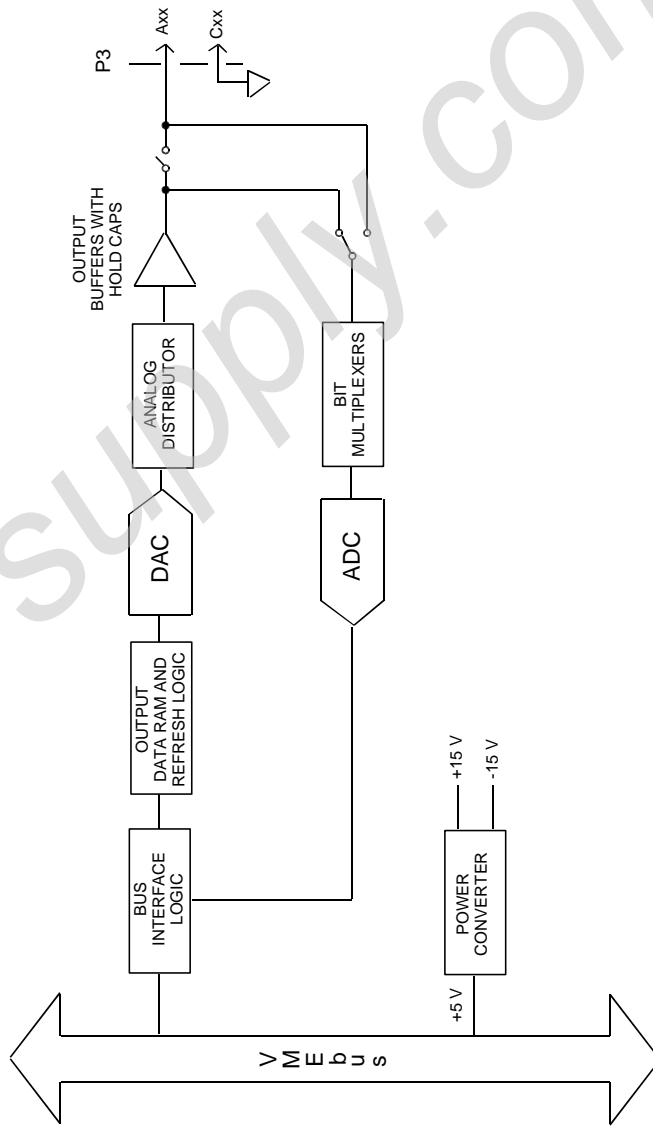

Safety Summary

Warning

The following general safety precautions must be observed during all phases of this operation, service, and repair of this product. Failure to comply with these precautions or with specific warnings elsewhere in this manual violates safety standards of design, manufacture, and intended use of this product. GE Fanuc assumes no liability for the customer's failure to comply with these requirements.

Ground the System

To minimize shock hazard, the chassis and system cabinet must be connected to an electrical ground. A three-conductor AC power cable should be used. The power cable must either be plugged into an approved three-contact electrical outlet or used with a three-contact to two-contact adapter with the grounding wire (green) firmly connected to an electrical ground (safety ground) at the power outlet.

Do Not Operate in an Explosive Atmosphere

Do not operate the system in the presence of flammable gases or fumes. Operation of any electrical system in such an environment constitutes a definite safety hazard.

Keep Away from Live Circuits

Operating personnel must not remove product covers. Component replacement and internal adjustments must be made by qualified maintenance personnel. Do not replace components with power cable connected. Under certain conditions, dangerous voltages may exist even with the power cable removed. To avoid injuries, always disconnect power and discharge circuits before touching them.

Do Not Service or Adjust Alone

Do not attempt internal service or adjustment unless another person, capable of rendering first aid and resuscitation, is present.

Do Not Substitute Parts or Modify System

Because of the danger of introducing additional hazards, do not install substitute parts or perform any unauthorized modification to the product. Return the product to GE Fanuc for service and repair to ensure that safety features are maintained.

Chapter 2

Configuration and Installation

This chapter provides configuration and installation instructions for the Analog Output Board, and is divided into the following sections:

- Physical Installation
- Before Applying Power: Checklist
- Base Address Configuration
- Calibration
- Connector Descriptions

Caution

Some of the components assembled on GE Fanuc products can be sensitive to electrostatic discharge and damage can occur on boards that are subjected to a high-energy electrostatic field. When the board is placed on a bench for configuring, etc., it is suggested that conductive material be placed under the board to provide a conductive shunt. Unused boards should be stored in the same protective boxes in which they were shipped.

Upon receipt, any precautions found in the shipping container should be observed. All items should be carefully unpacked and thoroughly inspected for damage that might have occurred during shipment. The board(s) should be checked for broken components, damaged printed circuit board(s), heat damage, and other visible contamination. All claims arising from shipping damage should be filed with the carrier and a complete report sent to GE Fanuc together with a request for advice concerning the disposition of the damaged item(s).

Physical Installation

Caution

Do not install or remove board while power is applied.

De-energize the equipment and insert the board into an appropriate slot of the chassis. While ensuring that the board is properly aligned and oriented in the supporting board guides, slide the board smoothly forward against the mating connector until firmly seated.

PDFsupply.com

Before Applying Power: Checklist

Before installing the board in a VMEbus system, check the following items to ensure that the board is ready for the intended application.

- Have the sections pertaining to programming and theory, chapters 3 and 4, been reviewed and applied to system requirements?
- Review “Factory-Installed Jumpers” and Table 2-1 on page 2-4 to verify that all factory-installed jumpers are in place. To change the board address or address modifier response, refer to “Board Address Selection (J5 and J7)” on page 2-6.
- Have the I/O cables, with the proper mating connectors, been connected to the output connector P3? Refer to “Connector Descriptions” on page 2-13 for a description of the P3 connector.
- Calibration has been performed at the factory. If recalibration is required, refer to “Calibration” on page 2-9.

Base Address Configuration

Control of the Analog Output Board's base address and I/O access mode is determined by field replaceable, on-board jumpers. This section describes the use of these jumpers, and their effects on board performance. The locations and functions of all Analog Output Board jumpers are shown in Figure 2-1 on page 2-5 and Table 2-1 below.

Factory-Installed Jumpers

Each Analog Output Board is configured at the factory with the specific jumper arrangement shown in Table 2-1 below. The factory configuration establishes the following functional baseline for the Analog Output Board, and ensures that all essential jumpers are installed.

- Base short I/O address is set at 0000 HEX.
- I/O access mode is short supervisory.
- Analog output and loopback ranges are set to ± 10 V full scale.

Table 2-1. Jumper Functions and Factory Configuration

Jumper Name	Jumper Function	Factory Configuration
J7	ADDRESS DECODE OF Bit A07	INSTALLED
J6	NONPRIVILEGED/SUPERVISORY I/O	OMITTED
J5	ADDRESS DECODE OF Bits A08 to A15	INSTALLED
J4	LOOPBACK VOLTAGE RANGE	INSTALLED AT 1-2
J3	LOOPBACK VOLTAGE POLARITY	INSTALLED AT 1-2
J2	OUTPUT VOLTAGE POLARITY	INSTALLED AT 2-3
J1	OUTPUT VOLTAGE RANGE	OMITTED

Figure 2-1: Jumper and Calibration Point Locations

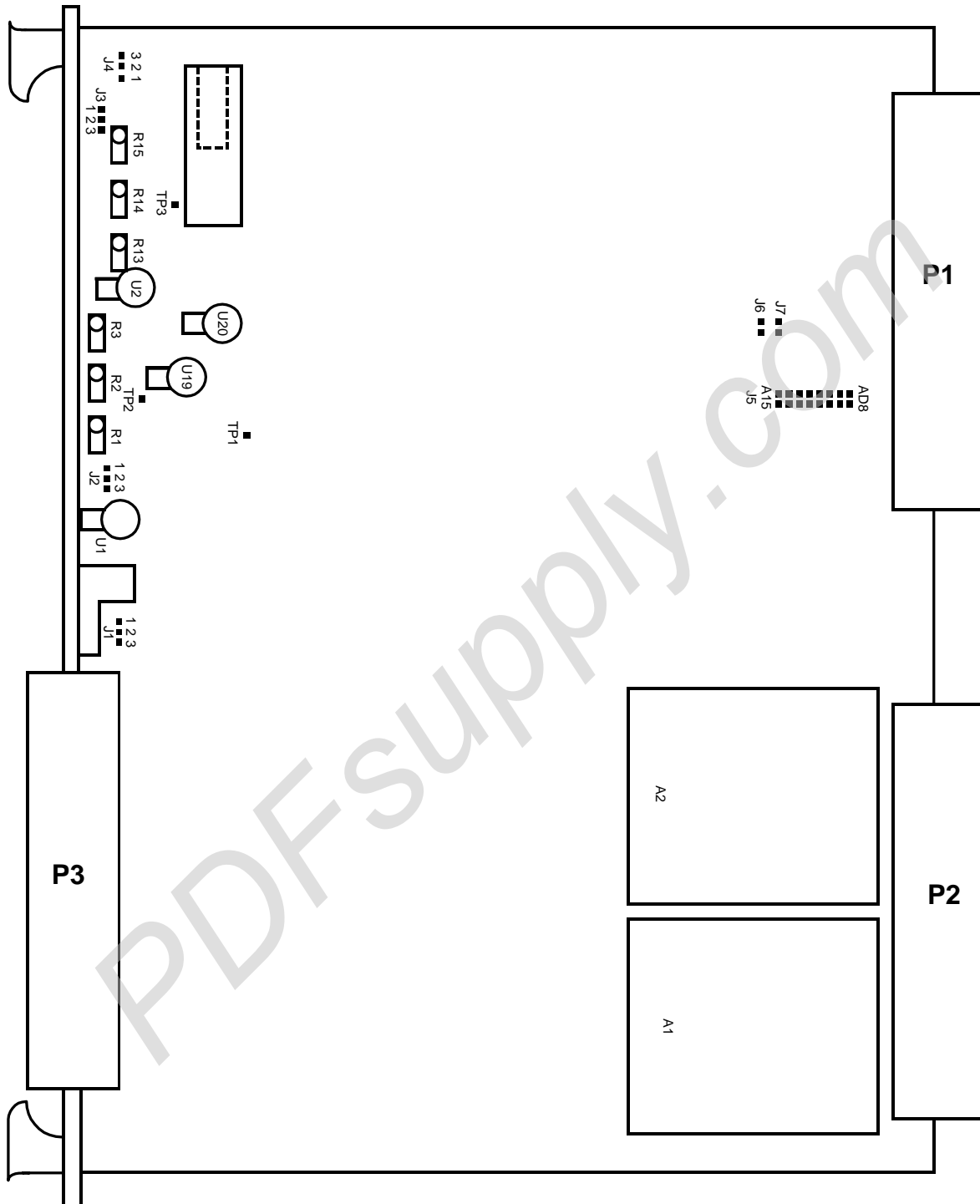

Board Address Selection (J5 and J7)

Jumpers J5 and J7 permit the Analog Output Board to be located on any 64-byte boundary within the short I/O address space. The short I/O address space consists of all the addresses between NNNN0000 HEX and NNNNFFFF HEX*. The Analog Output Board address is defined by nine lines, address bits A07 through A15. Six additional lines are used for programming the on-board registers (see Chapter 3 for more details).

In programming the board's base address, an installed jumper equals zero (0), and an omitted jumper equals one (1). Figure 2-2 below shows an example base address as well as the factory-configured base address.

Figure 2-2: Base Address Selection

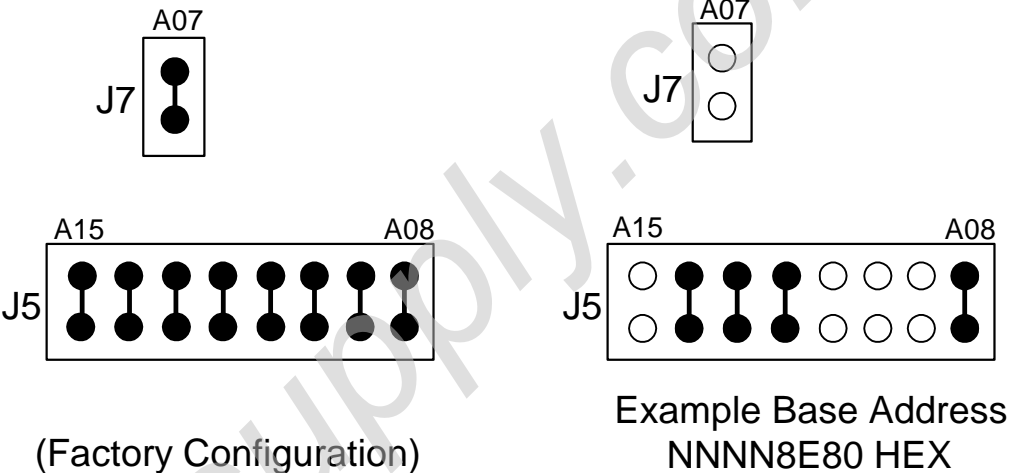

Board Modifier Selection (J6)

The I/O access mode is programmed by selecting the responding state of the address modifier AM2 with jumper J6. Short supervisory access is the factory configuration and is selected by omitting the jumper. Short nonprivileged access is selected by installing the jumper. Figure 2-3 below shows the jumper location for the two different accesses.

*The value NNNN depends on the make and model of the CPU board used.

Figure 2-3: Address Modifier Selection

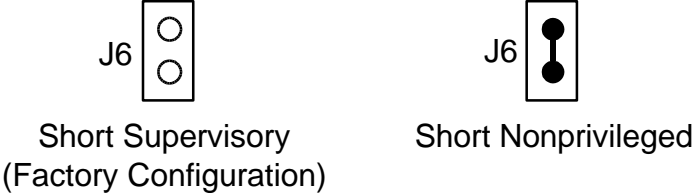

Analog Output Voltage Range (J1 and J2)

The output voltage range is controlled by jumper J1. The factory configuration is the maximum full-scale range of 20 V. To change this value to 10 V, place a jumper in position 1-2. For a range of 5 V, place a jumper in position 2-3.

Bipolar or unipolar operation of the analog outputs is selected with jumper J2. The board uses unipolar operations if a jumper is in position 1-2. If the jumper is in position 2-3, the outputs operate in bipolar mode (factory configuration).

Figure 2-4 below shows the jumper locations for the different configurations.

Figure 2-4: Analog Output Voltage Range Selection

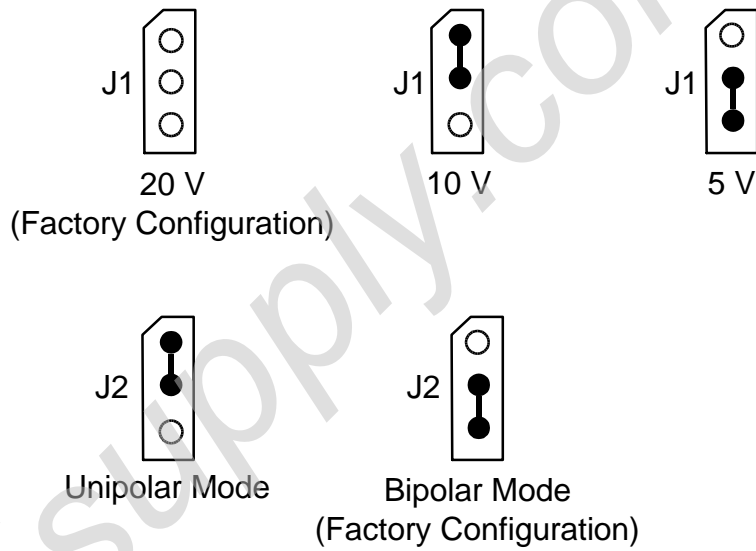

Loopback Input Voltage Range (J3 and J4)

The loopback multiplexers drive an ADC (Analog-to-Digital Converter chip). The loopback voltage range and polarity must be the same as the output voltage range. If not, the ADC produces the wrong values. These conditions are controlled by jumpers J3 and J4. As with the outputs, the maximum full-scale range is 20 V. To modify the full-scale range for 5 V or 10 V, place the jumper at J4 in position 2-3. For 20 V operations, put the jumper in position 1-2.

Bipolar or unipolar operation is selected with jumper J3. When J3's jumper is in position 1-2, the board operates in the bipolar mode. For unipolar voltages, place the jumper in position 2-3.

Figure 2-5: Loopback Input Voltage Range Selection

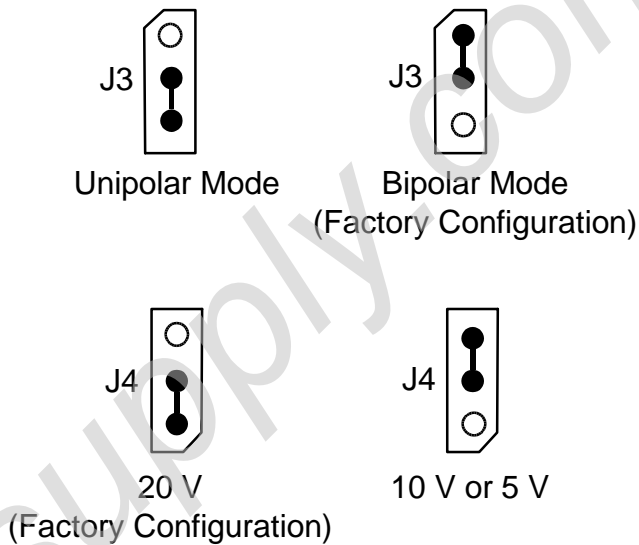

Do not take readings of any output channel that was updated less than 3.4 msec before or you will read the old value of the outputs. The sequencer needs this time to refresh the output S&H buffer. Also, give the loopback multiplexer 5 msec after a start convert command before reading the ADC to give the multiplexer time to settle.

Calibration

Before delivery from the factory, the Analog Output Board is fully calibrated and conforms to all specifications for bipolar operations. Should recalibration be required, perform the procedures in “Analog Output Calibration Procedure” on page 2-11 and “Loopback Input Calibration Procedure” on page 2-12 with the equipment listed in “Equipment Required” below. The locations of all adjustments and test points are shown in Figure 2-6 on page 2-10.

As delivered from the factory, all calibration adjustments are sealed against accidental movement. However, the seals are easily broken for recalibration. All adjustments should be resealed with a suitable fast-curing sealing compound after recalibration has been completed.

Note

Do not install or remove this board with power applied to the system.

Equipment Required

- **Digital Voltmeter (DVM)** – A meter with ± 1.0000 VDC and ± 10.000 VDC ranges, 5 or more digits, accuracy of ± 0.005 percent, and 10 M Ω minimum input impedance.
- **Chassis** – VMEbus backplane or equivalent with J1 and J2 connectors, a VMEbus master controller, a +5 VDC ± 0.25 VDC power supply, and one slot allocated for testing the Analog Output Board.
- **Extender board** – One VMEbus extender board.
- **Test cables** – Test cables for the equipment listed above.

Figure 2-6: Calibration and Test Points

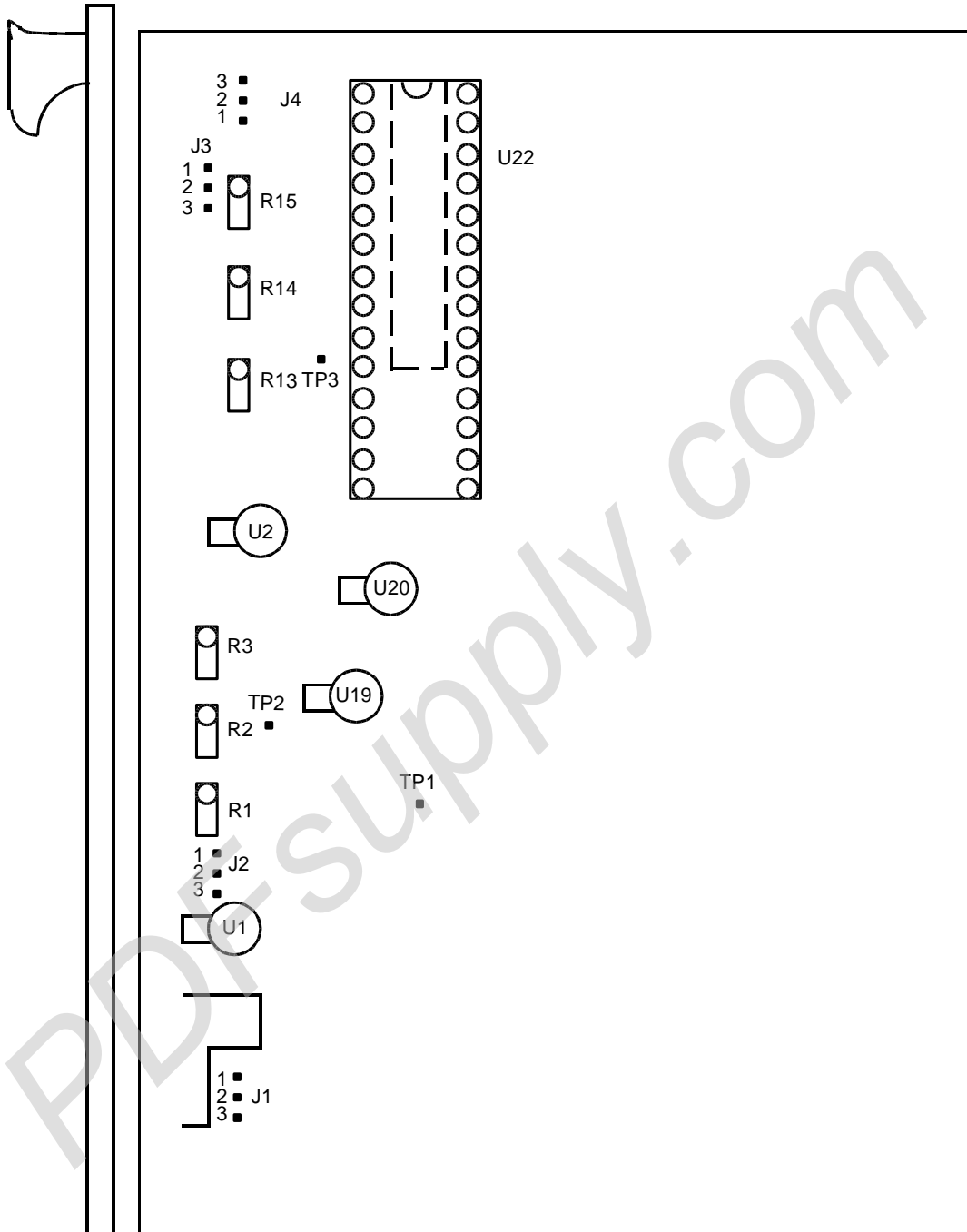

Analog Output Calibration Procedure

1. Install the Analog Output Board on the extender board in the VMEbus backplane.
2. Remove any jumper from J1. (This sets the outputs to 20 V full scale.)
3. Place the jumper at J2 to the 2-3 position. (This is the bipolar setting.)
4. Apply power to the backplane and allow a minimum ten minute warm-up time before proceeding.
5. Connect the digital voltmeter's positive (+) lead to TP2 and its negative (-) lead to TP1.
6. Write the 16-bit value 0000 HEX to all of the analog output channels. These registers begin at offset address 40 HEX and stop at offset 7E HEX.
7. Adjust R1 for a digital voltmeter indication of 0.0000 ± 0.0010 VDC.
8. Write the 16-bit value 07FF HEX to all of the analog output channels. These registers begin at offset address 40 HEX and stop at offset 7E HEX.
9. Adjust R2 for a digital voltmeter indication of $+9.9951 \pm 0.0010$ VDC.

(If the board is to be used in the Unipolar mode, perform steps 10, 11, and 12.)

10. Move the J2 jumper to the 2-1 position, and place a jumper on J1 in the 1-2 position.
11. Write the 16-bit value 0800 HEX to all of the analog output channels.
12. Adjust R3 for a digital voltmeter indication of 0.0000 ± 0.0010 VDC.
13. For optimum performance, the gain may be adjusted. To make this adjustment, perform steps 8 and 9 above. Calibration of the analog outputs is complete. Remove power and all test connections. Restore the board to its original configuration.

Loopback Input Calibration Procedure

1. Perform the Analog Output Calibration Procedure before performing the Loopback Input Calibration.
2. Place the jumper at J4 in the 1-2 position. (This is the 20 V range.)
3. Place the jumper at J3 in the 1-2 position. (This is the bipolar setting.)
4. Write the 16-bit value 0000 HEX to all of the analog output channels. These registers begin at offset address 40 HEX and stop at offset 7E HEX.
5. Write the 16-bit value 7840 HEX to the CSR at offset address 02 HEX.
6. While reading the ADC (a 16-bit word at offset address 04 HEX), adjust R15 (BIPOLAR OFFSET) for a reading of 0000 ±0001 HEX.
7. Write the 16-bit value 0FFF HEX to all of the analog output channels. These registers begin at offset address 40 HEX and stop at offset 7E HEX.
8. While reading the ADC (a 16-bit word at offset address 04 HEX), adjust R14 (GAIN ADJ) for an ADC indication that alternates between 0FFE and 0FFF HEX.
9. Repeat steps d through h until no further adjustments are required.

(If the board is to be used in the Unipolar mode perform steps 10, 11, 12, and 13.)

10. Move jumper J3 to the 2-3 position. (UNIPOLAR OPERATION.)
11. Write the 16-bit value 0000 HEX to all of the output channels. These registers begin at offset 40 HEX and end at offset 7E HEX.
12. Write the 16-bit value 7840 HEX to the CSR at offset address 02 HEX.
13. While reading the ADC, adjust R13 (UNIPOLAR ZERO ADJUST) for an ADC indication of 0000 ±1 HEX.
14. For optimum performance, the gain may be adjusted. To make this adjustment, perform steps 8 and 8 above. Calibration of the loopback inputs is complete. Restore the board to its original configuration.

Note

Steps 5, 6, and 8 (as well as steps 12 and 13) may require a program to make these adjustments.

Connector Descriptions

Two 96-pin DIN connectors, P1 and P2 (Figure 2-1 on page 2-5), provide the VMEbus connections to the Analog Output Board. P1 contains the address, data and control lines, and all additional signals necessary to control the VMEbus functions related to the board. P2 provides some additional power connections for the board. A 64-pin DIN connector (P3) is used to connect the analog outputs to the user's system. The orientation of the P3 connector is shown in Figure 2-7 on page 2-14, and the signal assignments are listed in Table 2-2 below. A twisted-pair ribbon cable with an overall shield is recommended for applications involving low-level signals in environments with a high degree of electrical noise.

Table 2-2: P3 Pin Channel Assignments.

Pin No.	Row A Assignment	Row C Assignment
1	CH00	GND
2	CH01	GND
3	CH02	GND
4	CH03	GND
5	CH04	GND
6	CH05	GND
7	CH06	GND
8	CH07	GND
9	CH08	GND
10	CH09	GND
11	CH10	GND
12	CH11	GND
13	CH12	GND
14	CH13	GND
15	CH14	GND
16	CH15	GND
17	CH16	GND
18	CH17	GND
19	CH18	GND
20	CH19	GND
21	CH20	GND
22	CH21	GND
23	CH22	GND
24	CH23	GND
25	CH24	GND
26	CH25	GND
27	CH26	GND
28	CH27	GND
29	CH28	GND
30	CH29	GND
31	CH30	GND
32	CH31	GND

Figure 2-7: P3 Connector Pinout

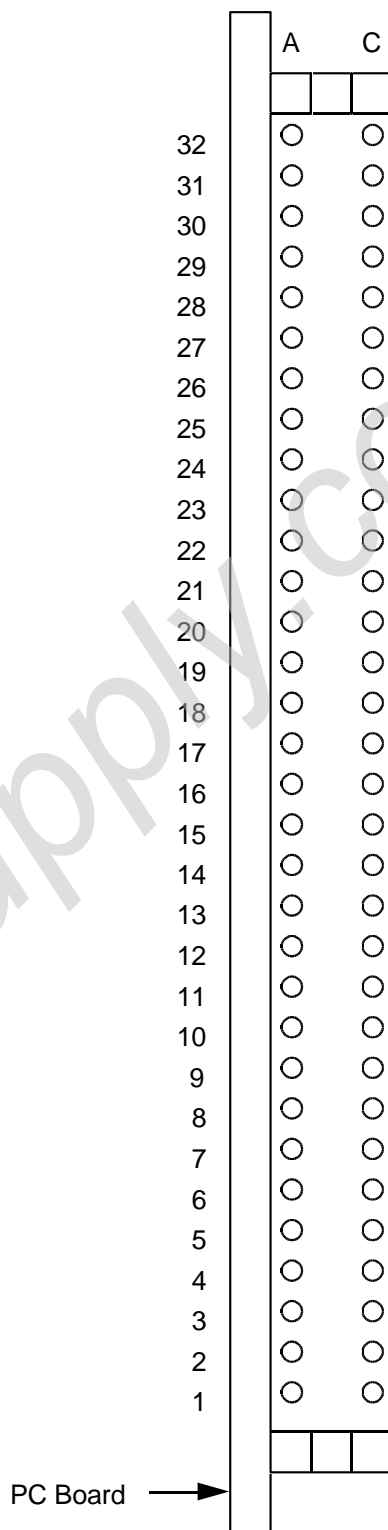

Chapter 3

Programming

This chapter contains programming instructions for the Analog Output Board, and is divided into the following sections:

- Introduction to Controlling the Analog Output Board
- Control and Status Register Descriptions
- Initialization
- Controlling the Analog Outputs
- Testing the Analog Output Channels (BIT)
- Program Example

Introduction to Controlling the Analog Output Board

Communication with the Analog Output (AO) Board takes place through 64 contiguous 16-bit register locations mapped into the VMEbus short I/O address space. The short I/O address space consists of all locations within the address range from NNNN0000 HEX to NNNNFFFF HEX*. The functions of the board's registers are summarized in Table 3-1 on page 3-5. These functions will be discussed in more detail later in this section.

The base address of the board holds the Board Identification Register. It is a read-only register that has a fixed value (17xx HEX). This register can be used by system initialization or automatic system configuration software. All of the other registers on the board are offset from the address assigned to this register.

* The value of NNN depends on the make and model of the controlling CPU.

Control and Status Register Descriptions

The Control and Status Register (CSR) is located at offset address 02 HEX. It contains all of the flags necessary to control and monitor the following board operations:

- Analog outputs on-line/off-line status
- Analog outputs refresh rate
- Digital-to-Analog (D/A) conversion
- Built-in-Test (BIT) and A/D control
- Analog input channel selection (Built-in-Test only)
- Front panel LED
- A/D and D/A enable/disable (Scan HALT)

The CSR is 16 bits long and is detailed in Table 3-2 on page 3-6. The function of each control bit and status flag is described in detail subsequently in the associated programming discussions.

Initialization

When SYSTEM RESET is applied to the board, the Control Register and all converter flags are cleared to the LOW state ("zero"). This places the board in a known state. The D/A output sequencer is stopped and the A/D converter is disabled. The data format is offset binary, standard settling time, the LED is ON, and the outputs are disconnected from the external circuits. In this condition, the board is ready to perform loopback tests. After the system RESET is removed, the D/A sequencer starts and the A/D converter is enabled. The A/D and the D/A can be disabled under software control. Setting the SCAN HALT bit to a "one" disables the A/D and the D/A. This bit must be cleared before normal operation can begin.

PDFSupply.com

Table 3-1: Analog Output Board Register Map

Offset Address in HEX	Register Name	Access Mode
00	BOARD ID	READ (17XX HEX)
02	CSR	READ/WRITE
04	ADC	READ
06 to 3E	(RESERVED)	-----
40	D/A OUTPUT 00	READ/WRITE
42	D/A OUTPUT 01	READ/WRITE
44	D/A OUTPUT 02	READ/WRITE
46	D/A OUTPUT 03	READ/WRITE
48	D/A OUTPUT 04	READ/WRITE
4A	D/A OUTPUT 05	READ/WRITE
4C	D/A OUTPUT 06	READ/WRITE
4E	D/A OUTPUT 07	READ/WRITE
50	D/A OUTPUT 08	READ/WRITE
52	D/A OUTPUT 09	READ/WRITE
54	D/A OUTPUT 10	READ/WRITE
56	D/A OUTPUT 11	READ/WRITE
58	D/A OUTPUT 12	READ/WRITE
5A	D/A OUTPUT 13	READ/WRITE
5C	D/A OUTPUT 14	READ/WRITE
5E	D/A OUTPUT 15	READ/WRITE
60	D/A OUTPUT 16	READ/WRITE
62	D/A OUTPUT 17	READ/WRITE
64	D/A OUTPUT 18	READ/WRITE
66	D/A OUTPUT 19	READ/WRITE
68	D/A OUTPUT 20	READ/WRITE
6A	D/A OUTPUT 21	READ/WRITE
6C	D/A OUTPUT 22	READ/WRITE
6E	D/A OUTPUT 23	READ/WRITE
70	D/A OUTPUT 24	READ/WRITE
72	D/A OUTPUT 25	READ/WRITE
74	D/A OUTPUT 26	READ/WRITE
76	D/A OUTPUT 27	READ/WRITE
78	D/A OUTPUT 28	READ/WRITE
7A	D/A OUTPUT 29	READ/WRITE
7C	D/A OUTPUT 30	READ/WRITE
7E	D/A OUTPUT 31	READ/WRITE

Table 3-2: CSR Bit Definitions

MSB							
Bit D15	Bit D14	Bit D13	Bit D12	Bit D11	Bit D10	Bit D09	Bit D08
Short Settling or New Data Rdy	LED Control	Start a Conversion or Converter Busy	Two's Complement Control	Outputs On-Line Control	Not Used	Not Used	Fast Refresh

LSB							
Bit 07	Bit D06	Bit D05	Bit D04	Bit D03	Bit D02	Bit D01	Bit D00
Not Used	Start Settling or Settling Busy	Scan Halt	MUX A4	MUX A3	MUX A2	MUX A1	MUX A0

Control and Status Register Bit Definitions

- Bit D15:** **Short Settling or New Data Rdy** – Writing a "one" here reduces the time assigned for loopback settling from 5 to 3 msec. Reading a "one" here indicates that loopback data is ready for the host to read.
- Bit D14:** **LED Control** – This bit turns the LED ON with a logic "zero" and OFF with a logic "one".
- Bit D13:** **Start a Conversion or Converter Busy** – Writing a "one" here and at D06 begins a loopback conversion. Reading a "zero" tells the host that a conversion is done.
- Bit D12:** **Two's Complement Control** – When a "one" is written here, the data is in offset binary form. When a "zero" is written here, the data is in two's complement form.
- Bit D11:** **Outputs On-Line Control** – When this bit is a "one", the output buffers are driving the cable and loopback buffers monitor the P3 pins. When it is a "zero", the outputs are disconnected from the cable and the loopback buffers monitor the output amps.
- Bit D10:** **Not used.**
- Bit D09:** **Not Used.**
- Bit D08:** **Fast Refresh** – This speeds up the DAC control logic when a "one" is written here, so the outputs get updated faster.
- Bit D07:** **Not Used.**

-
- Bit D06:** **Start Settling or Settling Busy** – Writing a "one" here and at D13 begins a loopback conversion. Reading a "zero" tells the host that the signal settling time is done.
- Bit D05:** **Scan Halt** – Writing a "one" here will stop the output sequencer and disable the A/D converter. This bit must be cleared before normal operations can begin.
- Bit D04:** **MUX A4*** – Loopback (input channel select) multiplexer control line.
- Bit D03:** **MUX A3** – Loopback (input channel select) multiplexer control line.
- Bit D02:** **MUX A2** – Loopback (input channel select) multiplexer control line.
- Bit D01:** **MUX A1** – Loopback (input channel select) multiplexer control line.
- Bit D00:** **MUX A0** – Loopback (input channel select) multiplexer control line.

* The MUX signals are address lines. A decoder takes the state of these lines and selects the loopback buffer to convert.

Controlling the Analog Outputs

The 16 analog output channels appear to the controlling processor as 16 consecutive 16-bit words in the address space assigned to the Analog Output Board. The register map shown in Table 3-1 on page 3-5 lists the board-relative (or offset) address of each output channel. Each Analog Output Register supports both read and write operations, eliminating the need for corresponding "shadow" latches in the processor Random Access Memory (RAM) space.

Writing to the Outputs

Output voltage data is recognized in the Analog Output Registers as right-justified 12-bit binary data. When offset binary data is written to a register, the upper four bits, D12 to D15, are ignored and not retained for read back. If the board is using two's complement data, then these bits contain the sign of the output data. Each output responds to a new code within 3.4 msec after the code is written to the Output Register (0.85 msec in the FAST REFRESH MODE). Be sure to give the board ample time to update the output before reading its value in a loopback test.

FAST REFRESH

Setting the FAST REFRESH control bit (Table 3-2 on page 3-6) HIGH reduces the analog output REFRESH time from the default value of 3.4 to 0.85 msec. The FAST REFRESH MODE raises the output Nyquist frequency (maximum output signal frequency) from approximately 300 Hz to about 1.2 kHz. This is done by reducing the settling time given to the various circuits in the output channels. The FAST REFRESH MODE reduces the accuracy of the outputs. They are not given enough time to settle to their most accurate levels.

Testing the Analog Output Channels (BIT)

Built-in-Test (BIT) provisions provide loopback testing of the outputs. These capabilities permit self-contained, board-level verification of performance. The testing is controlled by seven bits in the CSR. They are the MUX Address lines, the start conversion, and start settling bits. The ON-LINE signal controls the source of the test voltage. The two's complement bit dictates the format of the data. BIT is available at any time. The user picks a channel to monitor and orders a conversion. After 5 msec, the ADC is read and the read data is compared to the written data to determine the "health" of the channel. If an error is detected, the front panel LED can be used to locate the board in a system for troubleshooting.

Loopback Testing of the Outputs

The five least significant bits in the CSR, D00 through D04, and bit D11 are used to select the source of the voltage used in the loopback (BIT) test. D00 through D04 are the loopback multiplexer select lines MUX A0 through MUX A4. They select the input to be tested. Bit D11, the outputs on-line control, selects where the input sample will be made. When this bit is low the loopback test buffers monitor the analog output buffers. If this bit is high, the test buffers monitor the output pins of P3. The loopback multiplexers are always enabled to prevent the ADC from trying to convert a high impedance input instead of a voltage. By routing the analog outputs through these loopback multiplexers, the operation of all the components on the Analog Output Board can be verified.

ADC Controls and Flags

All timing operations for the ADC are performed by an on-board controller. User control of the converter consists of the following control bits, flags, and registers. The control bits and flags in the CSR are summarized in Table 3-2 on page 3-6. They are restated here for clarity.

Table 3-3 CSR Bit Functions

Control Bits	
a. SHORT SETTling H . . .	D15 *
b. EN START CONV H	D13 *
c. TWO's COMPL L	D12
d. START SETTling H	D06 *

* Effective only upon writing ("strobed").

Flags (Status Register)	
a. NEW DATA RDY H	D15 *
b. CONV BUSY H	D13
c. SETTling BUSY H	D06

* Set when data is available in the ADC Data Register.

The START SETTling and START CONV controls are essentially strobes. They are effective only at the moment of writing to the Control Register. Although supplied as two separate control bits, they must be written to the register simultaneously along with the operating mode (TWO's COMPL L and SHORT SETTling H bits) and the input channel selection. Thus, a single write to the CSR can start a conversion. Once started, the user simply waits 5 msec and then reads the ADC. The NEW DATA RDY bit can be used as a pass or fail indicator. Polling this bit (or any other bit on the board) will degrade the loopback readings.

For example, to convert the signal of Channel 0, with the outputs on-line using offset binary data format, write 7840 HEX to the CSR. The low 5 bits select the output channel to monitor (Channel 0 in this case). The upper 4 bits start the conversion and select the data format. Now wait 5 msec to give the multiplexers time to settle. In this time, the host can do whatever it wants. The ADC is read next via the Converter Data Register (CDR). To check Channel 12, write 784C HEX to the CSR.

The CDR is a 16-bit *read-only* register at relative address 04 HEX. It is used to store the ADC data. Data in this register is 12 bits, right-justified. D12 through D15 are always "zero" in the binary data format, and are sign extensions in the two's complement data format. The data format depends upon the state of the TWO's COMP L control bit in the CSR. Converter output codes that are produced at major points within the full-scale ranges shown are summarized in Table 3-4.

Table 3-4 Data Codes for Some Selected Output Voltages

INPUT	UNIPOLAR RANGE		STRAIGHT BINARY		
	+5 V $V_{FSR=5V}$	+10 V $V_{FSR=10V}$	D15*	D00	HEX
+FS-1 LSB	+4.9988 V	+9.9976 V	0000 1111 1111 1111		FFF
3/4 FS	+3.7500 V	+7.5000 V	0000 1100 0000 0000		C00
1/2 FS	+2.5000 V	+5.0000 V	0000 1000 0000 0000		800
1/4 FS	+1.2500 V	+2.5000 V	0000 0100 0000 0000		400
1 LSB	+0.0012 V	+0.0024 V	0000 0000 0000 0001		001
ZERO	0.0000 V	0.0000 V	0000 0000 0000 0000		000

BIPOLAR RANGE		OFFSET BINARY			
INPUT	$\pm 5\text{ V}$ $V_{FSR=10\text{ V}}$	$\pm 10\text{ V}$ $V_{FSR=20\text{ V}}$	D15*	D00	HEX
+FS-1 LSB	+4.9976 V	+9.9951 V	0000 1111 1111 1111		FFF
+3/4 FS	+3.7500 V	+7.5000 V	0000 1110 0000 0000		E00
+1/2 FS	+2.5000 V	+5.0000 V	0000 1100 0000 0000		C00
+1/4 FS	+1.2500 V	+2.5000 V	0000 1010 0000 0000		A00
+1 LSB	+0.0024 V	+0.0048 V	0000 1000 0000 0001		801
ZERO	0.0000 V	0.0000 V	0000 1000 0000 0000		800
-1/4 FS	- 1.2500 V	- 2.5000 V	0000 0110 0000 0000		600
-1/2 FS	- 2.5000 V	- 5.0000 V	0000 0100 0000 0000		400
-3/4 FS	- 3.7500 V	- 7.5000 V	0000 0010 0000 0000		200
-FS+1 LSB	- 4.9976 V	- 9.9951 V	0000 0000 0000 0001		001
-FS	- 5.0000 V	- 10.000 V	0000 0000 0000 0000		000

BIPOLAR RANGE		2's COMPLEMENT			
INPUT	$\pm 5\text{ V}$ $V_{FSR=10\text{ V}}$	$\pm 10\text{ V}$ $V_{FSR=20\text{ V}}$	D15*	D00	HEX
+FS-1 LSB	+4.9976 V	+9.9951 V	0000 0111 1111 1111		7FF
+3/4 FS	+3.7500 V	+7.5000 V	0000 0110 0000 0000		600
+1/2 FS	+2.5000 V	+5.0000 V	0000 0100 0000 0000		400
+1/4 FS	+1.2500 V	+2.5000 V	0000 0010 0000 0000		200
+1 LSB	+0.0024 V	+0.0048 V	0000 0000 0000 0001		001
ZERO	0.0000 V	0.0000 V	0000 0000 0000 0000		000
-1/4 FS	- 1.2500 V	- 2.5000 V	1111 1110 0000 0000		E00
-1/2 FS	- 2.5000 V	- 5.0000 V	1111 1100 0000 0000		C00
-3/4 FS	- 3.7500 V	- 7.5000 V	1111 1010 0000 0000		A00
-FS+1 LSB	- 4.9976 V	- 9.9951 V	1111 1000 0000 0001		801
-FS	- 5.0000 V	- 10.000 V	1111 1000 0000 0000		800

STRAIGHT BINARY: $V_O = V_{FSR} (D1 \div 4096)$, D1 = Dec. equiv. of HEX value

OFFSET BINARY: $V_O = V_{FSR} (D1 \div 4096) - (V_{FSR} \div 2)$. D2 = Dec. equiv. of HEX value

2's COMPLEMENT: $V_O = V_{FSR} (D2 \div 4096) - (V_{FSR} \div 2)$. D2 = Dec. equiv. of (HEX value \oplus \$800)

* = Zero (binary) or extended sign (2's comp); \oplus = Exclusive OR'd with.

For any offset binary converter output code (BIPOLAR RANGE), the associated output voltage is obtained with the expressions:

$$\text{OUTPUT (Volts)} = (-E_{\text{FSR}}/2) + (E_{\text{FSR}} \times [\text{OUTPUT DATA IN DECIMAL}] / 4096).$$

The output voltage for a straight binary code (UNIPOLAR RANGE) is:

$$\text{OUTPUT (Volts)} = +E_{\text{FSR}} \times [\text{OUTPUT DATA IN DECIMAL}] / 4096.$$

Where E_{FSR} is the full-scale range voltage. (E.g.: $E_{\text{FSR}} = 10 \text{ V}$ for the $\pm 5 \text{ V}$ range.)

For example, the output voltage for a HEX value of 51A is found like this:

1. Convert 51A (HEX) to its decimal equivalent, which is 1306.
2. Identify the Range you are using, for example $\pm 5 \text{ V}$. This range uses the bipolar equation with $E_{\text{FSR}} = 10 \text{ V}$.
3. Compute the result by substituting these numbers in the equation

$$\text{OUTPUT (Volts)} = -(10/2) + (10 \times (1306/4096)) = -5 + (10 \times .32) = -1.81 \text{ V}.$$

Program Example

The following is a sample program to perform some simple board operations. The program is written in C.

```

/*
**                               VMIVME 4132 sample code header file
*/

typedef unsigned short word;           /* data type of word */
#define VME_SHORT_IO 0xfbff0000       /* Force Cpu short io */
#define vmic4132_base_address 0x0000 /* Jumper Field J5 & J7 */

struct vmivme4132 {
    word bid;                          /* board ID register */
    word csr;                          /* control status register */
    word adc;                          /* ADC converter data register */
    word reserved[29];                 /* unused - reserved */
    word dac[32];                      /* DAC channels 0 - 31 */
};

typedef struct vmivme4132 vmic4132_reg;

#define SHORT_SETTLING 0x8000 /* CSR control bits (write) */
#define LED_OFF 0x4000
#define START_CONVERT 0x2000
#define TWOS_COMPLEMENT0x1000 0x1000
#define OUTPUTS_ONLINE 0x0800
#define FAST_REFRESH 0x0100
#define START_SETTLING 0x0040
#define SCAN_HALT 0x0020

#define NEW_DATA_READY 0x8000 /* CSR status bits (read) */
#define CONVERTER_BUSY 0x2000
#define SETTLING_BUSY 0x0040

/*                               VMIVME 4132 sample code                               */

#include "x4132.h"

/* 4132 function declarations */

word read_id(vmic4132_reg * board);
word read_csr(vmic4132_reg * board);
void write_dac(word chan,word data,vmic4132_reg * board);
word read_adc(word chan,word ctrl,vmic4132_reg * board);

main()
{
    word board_id,status,adc_cword,data_in;

    /* init pointer to 4132 board */

    vmic4132_reg * vmic4132;
    vmic4132 = (vmic4132_reg *) (VME_SHORT_IO+vmic4132_base_address);

    vmic4132->csr = LED_OFF | OUTPUTS_ONLINE; /* init dac outputs */

    board_id = read_id(vmic4132);           /* read board id register */

    status = read_csr(vmic4132);           /* read control/status register */

    write_dac(0,0x100,vmic4132);           /* write dac channel 0 with 100 hex */

    /* init adc control word and read back dac output with adc converter */

    adc_cword = LED_OFF | START_CONVERT | OUTPUTS_ONLINE | START_SETTLING;
    data_in = read_adc(0,adc_cword,vmic4132);

    data_in = read_adc(0,adc_cword,vmic4132);

} /* end main */

```

```
/*
** 4132 function primitives
*/

word read_id(vmic4132_reg * board)
{
    return board->bid;
}

word read_csr(vmic4132_reg * board)
{
    return board->csr;
}

void write_dac(word chan,word data,vmic4132_reg * board)
{
    board->dac[chan] = data;
}

word read_adc(word chan,word ctrl,vmic4132_reg * board)
{
    board->csr = (ctrl+chan);
    while (!(board->csr & NEW_DATA_READY)); /* test new data ready bit */
    return board->adc;
}
```

This chapter describes the internal organization of the Analog Output Board, reviews the general principles of operation, and is divided into the following sections:

- Internal Functional Organization
- VMEbus Interface
- Channel Control Logic
- Analog Outputs
- Analog Output Buffers and Switches
- Data RAM and Refresh Logic
- Built-in-Test (BIT) Multiplexers and ADC Logic
- Built-in Power Converter

Internal Functional Organization

The Analog Output Board is designed to operate in a standard VMEbus system. The board contains a 12-bit Digital-to-Analog Converter (DAC), dedicated on-board registers to store the output data, sample-and-hold buffers (S&H) to place the voltage on the cable, and loopback analog switches to support Built-in-Test features. The BIT uses an on-board Analog-to-Digital Converter (ADC); therefore, no additional equipment is needed to test this board. The Analog Output Board is a flexible I/O element in a VMEbus system, which offers Built-in-Test and off-line operating features not found in many other products.

The Analog Output Board is divided into the following functional categories, as illustrated in Figure 1-1 on page 1-3. All of these functions will be discussed in detail in this section of the manual.

- VMEbus Interface
- Analog Outputs (DAC and Analog Distributor)
- Analog Output Buffers and Switches
- Data RAM and Refresh Logic
- BIT Multiplexers and ADC Logic
- Power Converter

VMEbus Interface

The board's Analog Output Data Registers are memory mapped as 32 (decimal) 16-bit words. These registers store the value of the output voltage for the associated output channel. These registers are contiguous, and are located 40 (HEX) offset from the base address of the board. The board occupies 128 bytes of the VMEbus short I/O address space and may be user-located on any 128-byte boundary in this region. The board can be user-configured to respond to short supervisory or short nonprivileged bus access. The board supports two additional registers for a user interface. These registers are the Board ID and the Control and Status Registers. Figure 4-1 on page 4-5 is a block diagram of the bus interface logic.

The board monitors the VMEbus. During any data transfer, the board-selection comparator determines if there is a match between the on-board selection jumpers (shown in Figure 4-1 on page 4-5) and the address and address modifier lines on the backplane. If there is no match, all VMEbus control signals are ignored. If there is a match, the appropriate board response will occur. The open-collector DTACK interface signal is then asserted (driven LOW). Subsequent removal of the *read* or *write* command by the Central Processing Unit (CPU) causes the board-generated DTACK signal to return to the OFF state, terminating the data transfer cycle. Although some of the registers on the board are read only, the board will respond to a *write* command at these locations. However, the data written will be lost.

After the board decides it is to respond, the following three groups of VMEbus signals control the board:

- Data Bus lines D00 to D15
- Address lines A01, A02, A03, A04, A05, and A06
- Bus Control Signals:
 1. WRITE*
 2. DS0* and DS1*
 3. SYS CLK

Data Bus lines are bi-directional and move data to or from the board through a pair of 8-bit data transceivers. They are controlled by board-select, the WRITE* line, and the data strobes (DS0* and DS1*). The data transceivers serve as a buffer between the internal data bus, which interconnects all data devices on the board, and the VMEbus. Although the board will respond to byte operations, word transfers are recommended. Byte transfers can cause erratic behavior in the outputs.

Address lines A01 through A06 map the 64 Data Registers into a 128-byte range within the VMEbus address space (Chapter 3). The control signals determine whether data is to be moved to the board (a write cycle) or from the board (a read cycle), provide the necessary data strobes (DS0, DS1), and supply a 16 MHz clock (SYS CLK) for use by the on-board timers. However, the SYS RESET input overrides all of the board's functions, resets all the timers and clears all of the flags in the CSR. A Board ID Register located at the base address of the board has a fixed value of 17 HEX in the even byte location. This register can be used by automatic system configuration software, to identify the board in a system. The CSR is located at an offset of 02 from the base address of the board.

The interface logic determines the bus control of the board, but the CSR contains the board-level operating controls and status flags for the system. Static controls (such as the LED ON line) are stored in the Control Register and are used primarily to establish the operating mode of the board. Status flags (such as NEW DATA RDY), necessary for monitoring and controlling the analog input multiplexer and the ADC, are read through the Status Register. The Control and Status Registers are referred to collectively as the Control and Status Register or CSR, since they are at the same address. The WRITE* signal determines which one is accessed, while most of the Control Register outputs can be monitored directly through the Status Register.

In the CSR, three of the control lines are strobes. These signals are START CONV H, SHORT SETTling H, and START SETTling H. They are valid only during the write operation to the CSR. Once written, these signals become status flags for the Analog-to-Digital Converter. The host CPU can monitor these lines to determine when the ADC is done and data is ready to be read.

Each of the 32 analog output channels is controlled by writing a 12-bit right-justified data word into a dedicated 16-bit read/write register. The 32 analog Output Control Registers constitute the VME port of a 32-word dual-port memory. The other memory port is controlled by the analog output refresh logic. The data format and the two's complement control bit must be consistent.

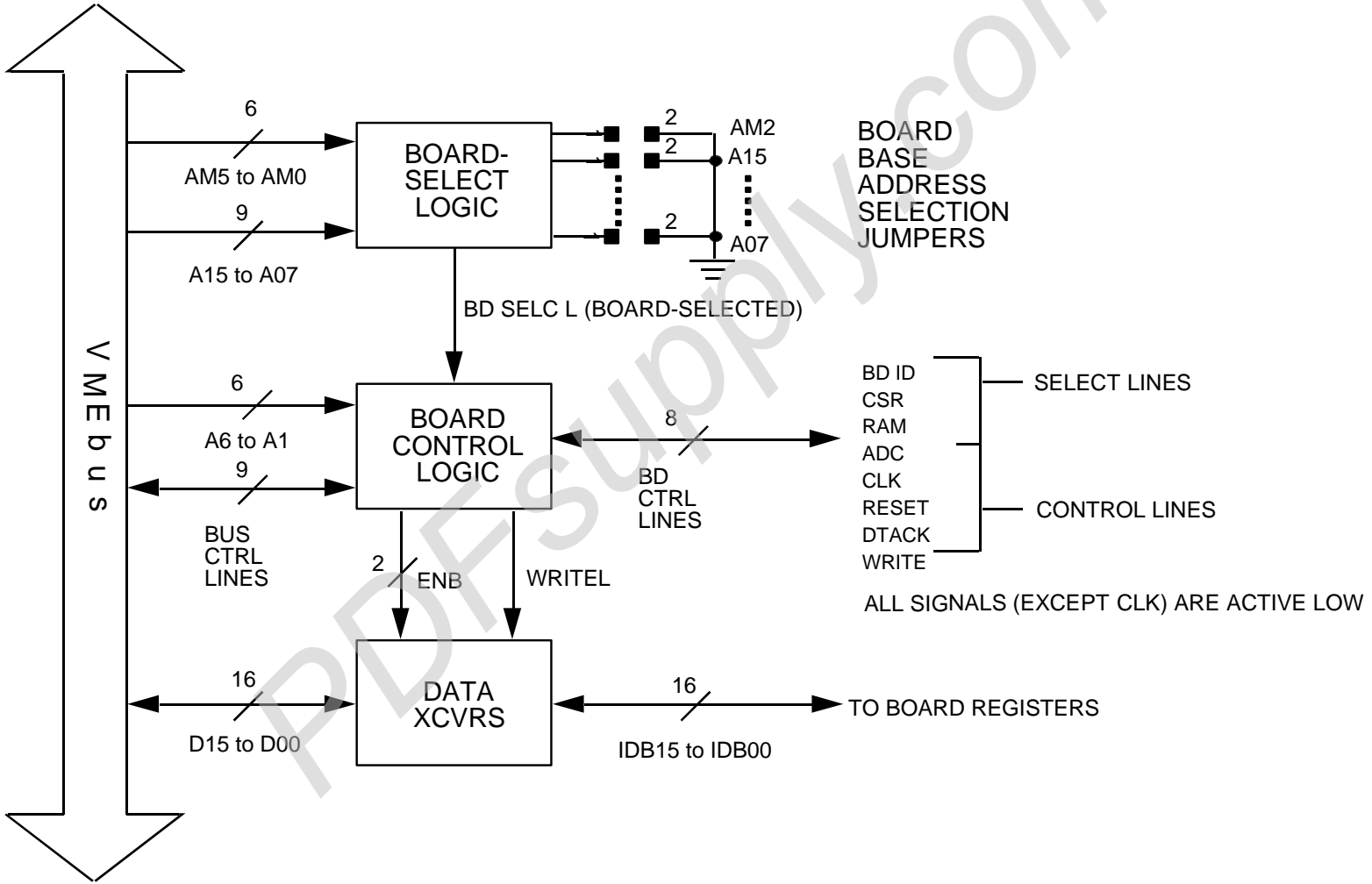

Figure 4-1: Interface Logic

Analog Outputs

Each analog output has its own sample-and-hold buffer and a control switch. The analog outputs are updated (refreshed) periodically from the dual-port memory by the refresh control logic, as illustrated in Figure 4-2 on page 4-7. Each output receives an update once every 3.4 msec in the default refresh mode. A program-controlled FAST REFRESH control bit can be used to reduce the refresh cycle time to approximately 0.85 msec, thereby raising the maximum output sampling rate from 294 Hz to 1.18 kHz. These rates assume there is no loopback activity on the board.

Digital-to-Analog Converter (DAC)

All 32 analog outputs are serviced by a single 12-bit DAC. The DAC is controlled by the refresh control logic. As long as the ADC is not converting a voltage, this circuitry will periodically transfer data from the dual-port memory's refresh port to the DAC. Simultaneously the logic connects the DAC to the appropriate section of the analog output demultiplexer (analog distributor). The analog output data is placed in the dual-port memory by the controlling processor through the VMEbus port.

Analog Distributor

The analog distributor consists of the following elements:

- A one of 32 output channel decoder
- Low charge injection analog demultiplexer (4 one of eight decoders)
- Thirty-two capacitive storage elements and buffers

The one of 32 decoder receives the same five address lines used to select the dual-port memory location used to update the DAC. In this manner, the converted analog level is always routed by the distributor section to the output buffer which corresponds to the dual-port memory location being updated. The upper two bits are decoded to yield a select line to choose the correct demultiplexer. The three lower bits are used to select the output to pass through the decoder. Figure 4-3 on page 4-10 shows the 1 of 32 decoder logic.

After allowing the DAC to settle, the refresh logic enables (turns ON) the demultiplexer. The converted voltage level is transferred to the corresponding storage capacitor. Approximately 100 msec of settling time is provided by the REFRESH logic for the sample-and-hold buffer. Then the demultiplexer is disabled and the next channel in the REFRESH sequence is accessed. During ADC conversions the refresh logic is disabled. This is to prevent the digital noise generated by this logic from injecting errors in the loopback data. When the ADC is converting a voltage, a 15 μ sec (maximum) delay will be added to the output update time.

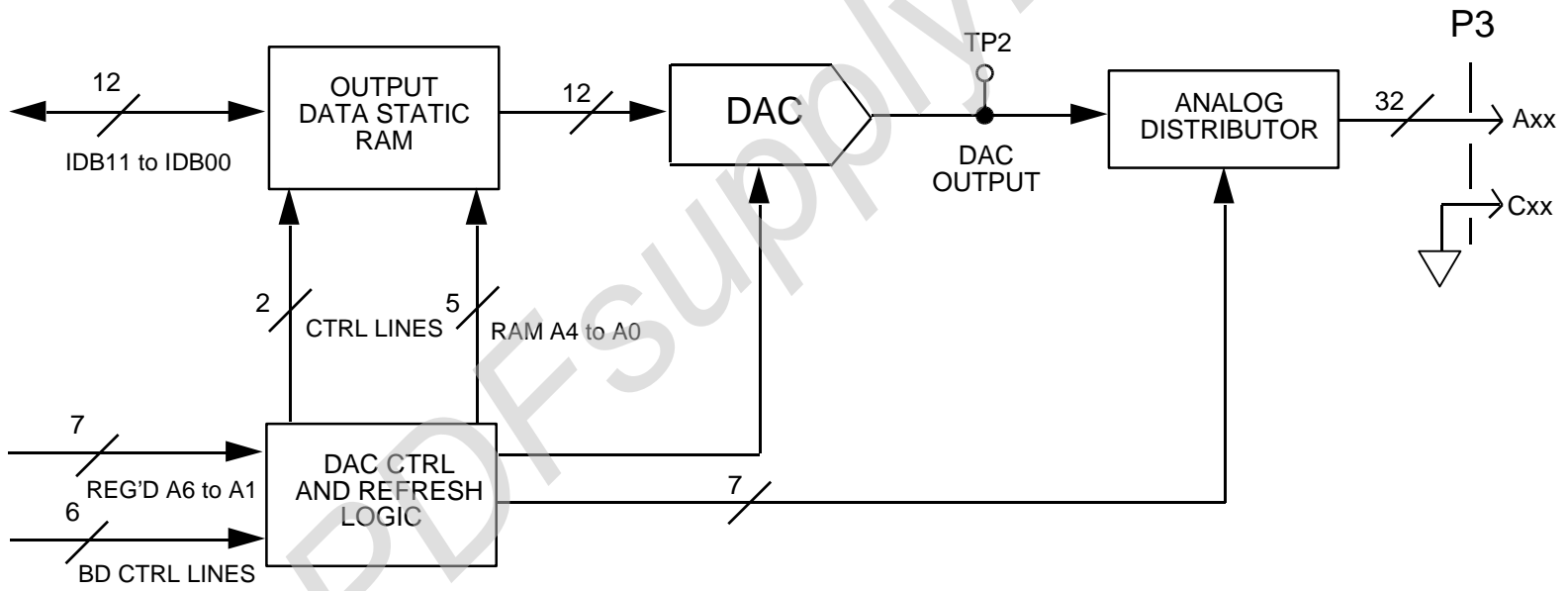

Figure 4-2: Analog Output Control Logic

Analog Output Buffers and Switches

Voltage levels processed by the analog distributor and stored by the sample-and-hold caps are buffered and then switched to the P3 connector for routing through the system I/O cables. The output buffers are low leakage, precision operational amplifiers which can supply 10 mA of drive current over the full available output voltage range of ± 10 V. These buffers can withstand sustained short circuits to ground without damage. Figure 4-4 on page 4-11 shows the S&H buffer with its protection circuit and the switches used to control the output connector and the loopback test voltage source.

The output switches can disconnect the output buffers from P3 for off-line testing and for low impedance, single-point analog I/O system applications. To eliminate the effect of switch resistance on the output impedance, the inverting (sense) input of each output buffer is switched between the load and line side of the output switch during on-line and off-line operations. Thus, the output impedance is the switch resistance divided by the open loop gain of the op-amp. Clamping diodes protect the buffers and switches from line transients by preventing voltage excursions beyond the ± 15 V supply rails.

Data RAM and Refresh Logic

The dual-port memory which services the analog outputs is organized as a 16-bit wide 32-column array. Each location can be accessed from either of two ports. The random access VME port is used by the VMEbus host to load the analog output digital codes into the memory. The digital codes are then transferred sequentially through the DAC port to the Digital-to-Analog Converter. There they are converted into voltage levels and subsequently distributed to the appropriate analog output channel.

The dual-port memory is controlled by the REFRESH control logic which derives its timing from the 16 MHz system clock. The REFRESH control logic supervises all data transfers between the memory and the DAC, and controls the distribution of the analog voltages to the outputs. Because the dual-port memory must be accessed through both the VME and DAC ports, arbitration logic is employed during the transfer of data to the DAC to ensure that only one port is active at any time.

The REFRESH control logic sequences through the output channels from 0 to 31. It writes the channel's digital data to the DAC at the same time it selects the correct output S&H buffer. It then performs the necessary time delays for each part of the logic (DAC, multiplexer, and output amplifier) to settle to the updated value. It also arbitrates the access to the RAM. When the VMEbus wants to access this RAM, it makes sure the output logic is in a state that will tolerate the interruption. The VMEbus then places the bus data into the RAM and signals the board interface logic when the transfer is done (scanning is then resumed).

When the loopback ADC is performing a conversion, the REFRESH control logic is stopped, thereby preventing it from generating noise which gets into the loopback ADC's input. This noise can cause a large error in the input voltage, making the host erroneously think that the board has failed. By freezing the REFRESH logic, the noise is eliminated. This will add up to 15 μ sec to the 3.4 msec update rate for each conversion (a .44 percent increase). This impact should not be a problem for the outputs, because the READ software should give 5 msec of settling time for the loopback multiplexers.

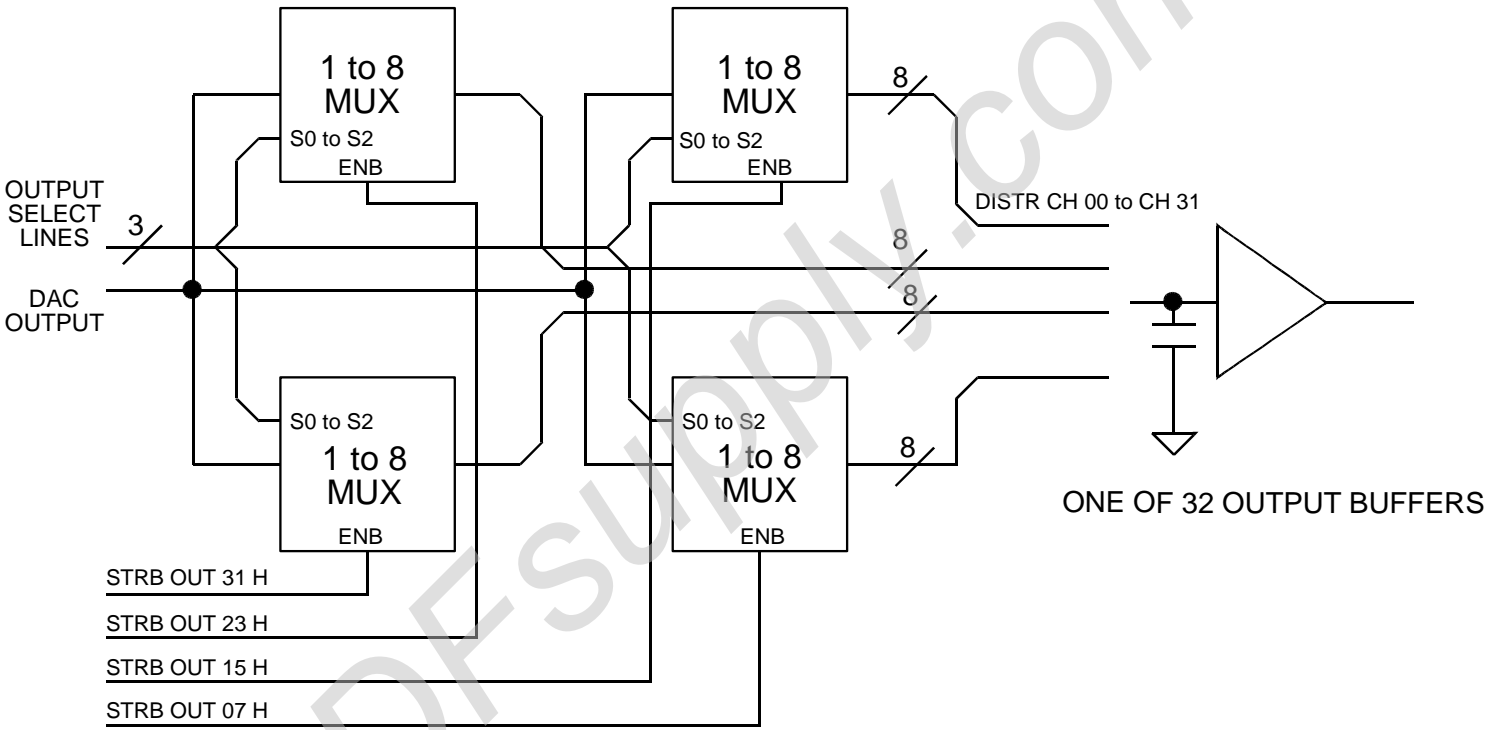

Figure 4-3: Analog Output Distribution

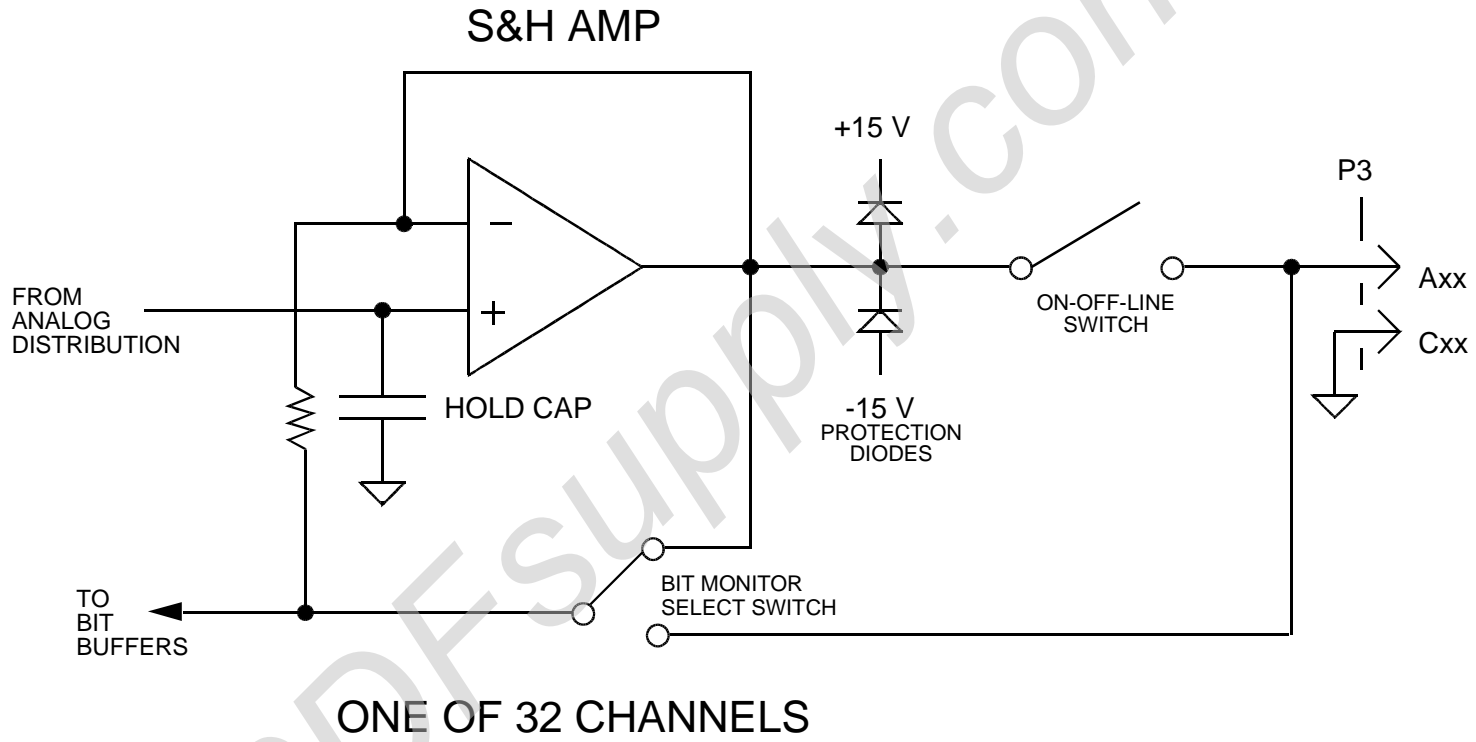

Figure 4-4: Simplified Output Buffers and Switches

Built-in-Test (BIT) Multiplexers and ADC Logic

The signal routing paths and multiplexers involved in the board's loopback testing are shown in Figure 4-5 on page 4-13. The 32 analog outputs are switched by the output monitor demultiplexer onto a single line. This line is connected to a buffer and then to the on-board Analog-to-Digital Converter (ADC). This arrangement permits any one of the analog outputs to be tested by the ADC. It also verifies the operation of the analog input multiplexers by exercising them with known signal levels.

By routing the analog outputs through the test demultiplexers, all of the active components on the board are exercised in a "loopback" arrangement. The controlling processor can perform a loopback test in either the on-line or off-line mode by sending a voltage-level code to a specific output channel and then verifying that the ADC produces the correct code for the output voltage sent (see Chapter 3 for more details).

Converter Controls and Status Flags

A conversion sequence is initiated by a single write to the CSR placing a "one" in the START SETTLING and the START CONV control bits and the channel to be converted. The last five bits contain the input channel information. The conversion sequence is composed of the following consecutive time intervals:

- Settling Delay
- Tracking Interval
- Analog-to-Digital (A/D) Conversion

All ADC timing intervals discussed in this section are performed automatically by the on-board controller. The host writes the CSR with the start settling and the start convert bits set and the desired channel. This will switch the demultiplexer to the desired channel and start the settling process. The host now waits 5 msec for the board's multiplexers to settle to the new voltage. During this time keep any digital activity to this board to a minimum. After the data ready bit has been set in the CSR, the host can read the data.

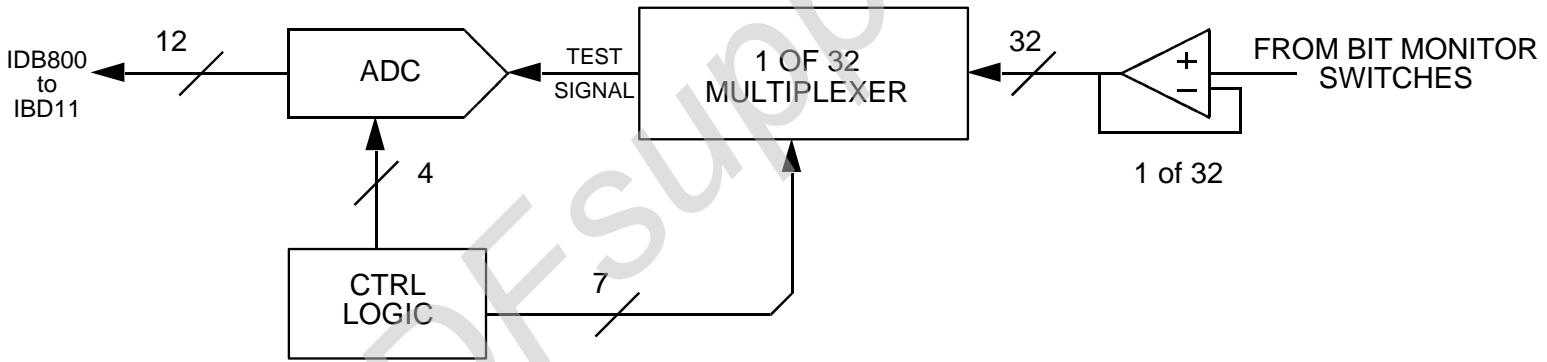
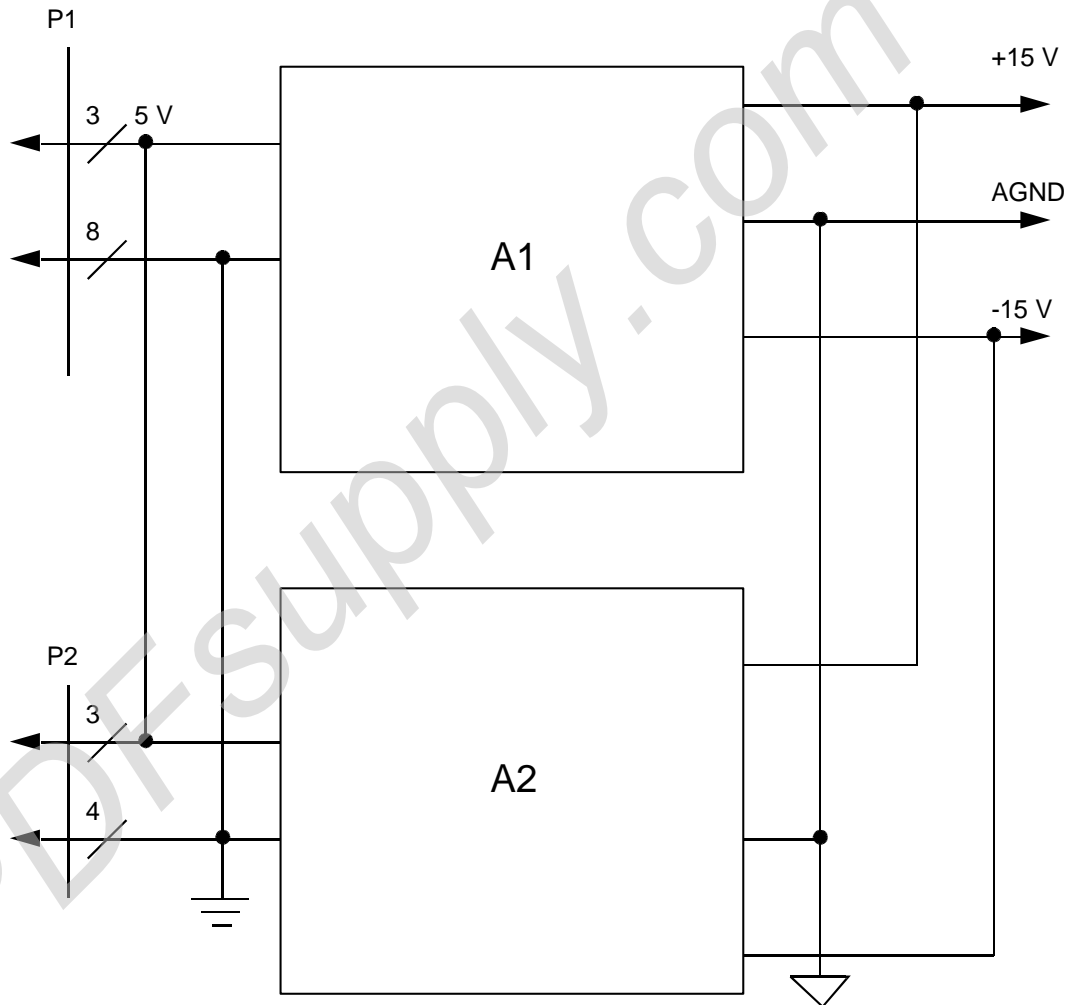

Figure 4-5: Simplified BIT Logic

Built-in Power Converter

Electrical power for the Analog Output Board analog network is supplied by two DC-to-DC converters shown in Figure 4-6 below. These converters transform the +5 V logic power into regulated and isolated ± 15 VDC power, with a load capacity of approximately 600 mA on each 15 V bus. Thus, the user only needs a +5 V power supply when using this board.

Figure 4-6: DC-to-DC Converters



Chapter 5

Maintenance

This chapter provides information relative to the care and maintenance of the Analog Output Board product.

If the product malfunctions, verify the following:

- Software
- System configuration
- Electrical connections
- Jumper or configuration options
- Boards fully inserted into their proper connector location
- Connector pins are clean and free from contamination
- No components of adjacent boards are disturbed when inserting or removing the board from the VMEbus card cage
- Quality of cables and I/O connections

User level repairs are not recommended. Contact GE Fanuc for a Return Material Authorization (RMA) Number. **This RMA Number must be obtained prior to any return.**