

## Functional Characteristics

**Board Functions:** There are 32 or 64 nonlatching relay contacts accessible through the two 96-pin DIN front panel connectors. One extra set of contacts (the NC set) is used for BIT.

**Compliance:** The IC697VDR150 and VDR151 conforms to the ANSI/IEEE STD 1014-1987 IEC 821 and 297 VMEbus specification with the following mnemonics: A24, A16: 3D/39, 2D/29: D32, D16, D08(E0): Slave.

**Addressing Scheme:** The base address of this board contains the board ID. Stacked above this 16-bit word is a 16-bit Control and Status Register (CSR). The Output Registers are placed at the next longword boundary above the CSR. Finally, the Contact Registers are stacked above the Output Registers. The Output and the Contact Registers are addressable as sixteen 8-bit bytes, eight 16-bit words, or four 32-bit longwords, located on any 128-bit boundary within standard data, short supervisory or nonprivileged I/O space.

**Board Addressing:** The board uses 20 jumpers to select its base address. One jumper determines the address space (standard data or short I/O) of the board. Another chooses supervisory, nonprivileged, or both access modes. The remaining 18 set up the base address of the board.

**Built-in-Test:** Board testing is accomplished by performing a read operation. Reading the address of the relay in question places the state of its Data Register on the bus. Reading the Contact Register transfers the state of the second NC contact to the bus. The data controlling the relay and the contact state can be compared. This is done because the relay takes so long (7ms maximum) to change its state. With this information, the user can determine when the relay contacts have changed state.

**Nonlatching Relays:** Nonlatching relays will NOT hold contact when power is interrupted. This permits resets and power loss to place the relays in their normal position. Thus, NO contacts will open and the NC contacts will close.

## Output Characteristics

### Contact Data:

**Contact Material:** Silver alloy (Gold clad)

**Maximum Switching Voltage:** 220VDC, 250VAC resistive load

**Maximum Switching Current:** 2A DC, AC resistive load

**Switching Power:** 60W or 125VA resistive

**Initial Contact Resistance:** 50mW (by voltage drop 6VDC 1A)

**Contact Connect Times:** Opening or Closing: 6.5ms maximum with .5ms typical bounce time

**Dielectric Strength:** 750VAC, 50/60Hz for 1 minute between contacts of the same pole

**Surge Withstand Voltage:** Conforms to Part 68 of FCC Regulations

**Service Life:**  $5 \times 10^5$  minimum operations at rated current

### Physical/Environmental

**Temperature:** 0 to +55°C, operating

-20 to +85°C, storage

**Humidity:** 20 to 80% relative, noncondensing

**Cooling:** Forced air convection

**Dimensions:** Double Eurocard (160 x 233.35mm)

**Output Connector:** Two front panel mounted 96-pin DIN connectors

**Power Requirements:** 4A maximum at +5VDC

**MTBF:** 69,800 hours (MIL STD 217F)

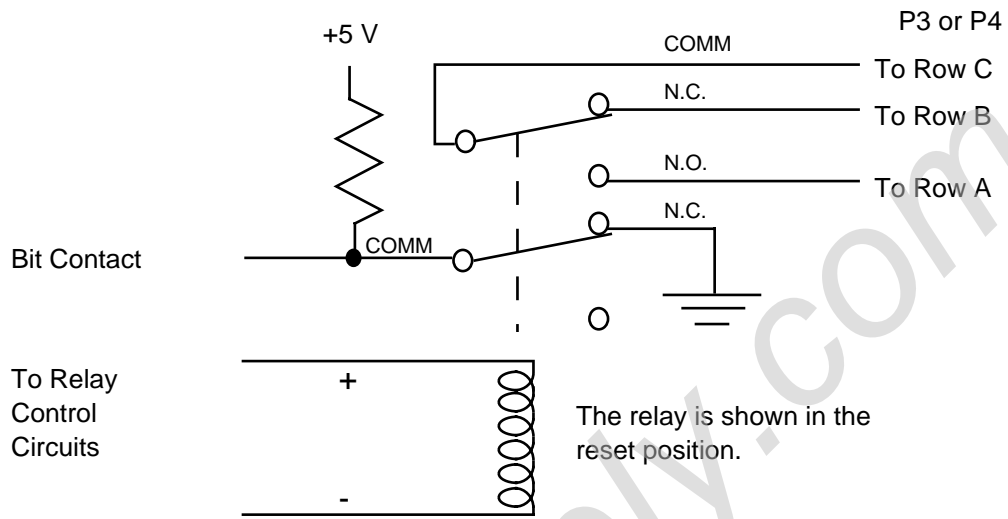

Figure 1. Typical Relay Circuit