

Warnings, Cautions, and Notes as Used in this Publication

Warning

Warning notices are used in this publication to emphasize that hazardous voltages, currents, temperatures, or other conditions that could cause personal injury exist in this equipment or may be associated with its use.

In situations where inattention could cause either personal injury or damage to equipment, a Warning notice is used.

Caution

Caution notices are used where equipment might be damaged if care is not taken.

Note

Notes merely call attention to information that is especially significant to understanding and operating the equipment.

This document is based on information available at the time of its publication. While efforts have been made to be accurate, the information contained herein does not purport to cover all details or variations in hardware or software, nor to provide for every possible contingency in connection with installation, operation, or maintenance. Features may be described herein which are not present in all hardware and software systems. GE Fanuc Automation assumes no obligation of notice to holders of this document with respect to changes subsequently made.

GE Fanuc Automation makes no representation or warranty, expressed, implied, or statutory with respect to, and assumes no responsibility for the accuracy, completeness, sufficiency, or usefulness of the information contained herein. No warranties of merchantability or fitness for purpose shall apply.

The following are trademarks of GE Fanuc Automation North America, Inc.

Alarm Master	Genius	PROMACRO	Series Six
CIMPLICITY	Helpmate	PowerMotion	Series Three
CIMPLICITY 90-ADS	Logicmaster	PowerTRAC	VersaMax
CIMSTAR	Modelmaster	Series 90	VersaPro
Field Control	Motion Mate	Series Five	VuMaster
GEnet	ProLoop	Series One	Workmaster

Contents

Chapter 1 **Introduction, Description, and Specifications 1-1**
 General Description 1-2
 Hard Disk Drive (J1) and Floppy Disk Drive (J3) Headers 1-5
 SBC Board Compatibility 1-9
 Safety Summary 1-15

Chapter 2 **Maintenance..... 2-1**

This manual describes the installation of the IC697VHD001 VMEbus Hard Disk Module, and is divided into the following sections:

- Hard Disk Drive (J1) Header
- CPU Board Compatibility
- Board Connection Options
- Chassis Layout Examples

PDFSupply.com

General Description

The Disk Module is a passive hard drive module. The board is a 6U VMEbus form factor, deriving its power from the standard VMEbus P1 and P2 backplane connectors.

The Disk Module is designed to interface with GE Fanuc's VMEbus-compatible PC/AT Single Board Computer (SBC). The SBC has the IDE controller on-board.

Connection to the SBC is obtained using flat ribbon cables that emerge from the component side of the Disk Module. The cables are connected directly to the SBC without creating any cable clutter on the front panel. The Disk Module route all hard drive signals directly to the P2 backplane connector when used with compatible SBC products.

Disk Module features include:

- Hard Disk Drive
- Standard VMEbus 6U single-slot form factor
- Low power consumption
- Flexible cable connectivity eliminating front panel clutter

Warning

Do not power up the unconnected Disk Module. Powering up an unconnected module will cause the loss of any software configuration on the Disk Module hard disk.

Note

When removing the SBC board and the Disk Module from the chassis, first eject the Disk Module, then eject the SBC and slide both boards out of the chassis simultaneously.

Board Layout

The Disk Module uses jumpers to configure the board for a variety of applications. Figure 1-1 below illustrates the location of all the components that make up the IC697VHD001.

Figure 1-1: Disk Module Board Layout

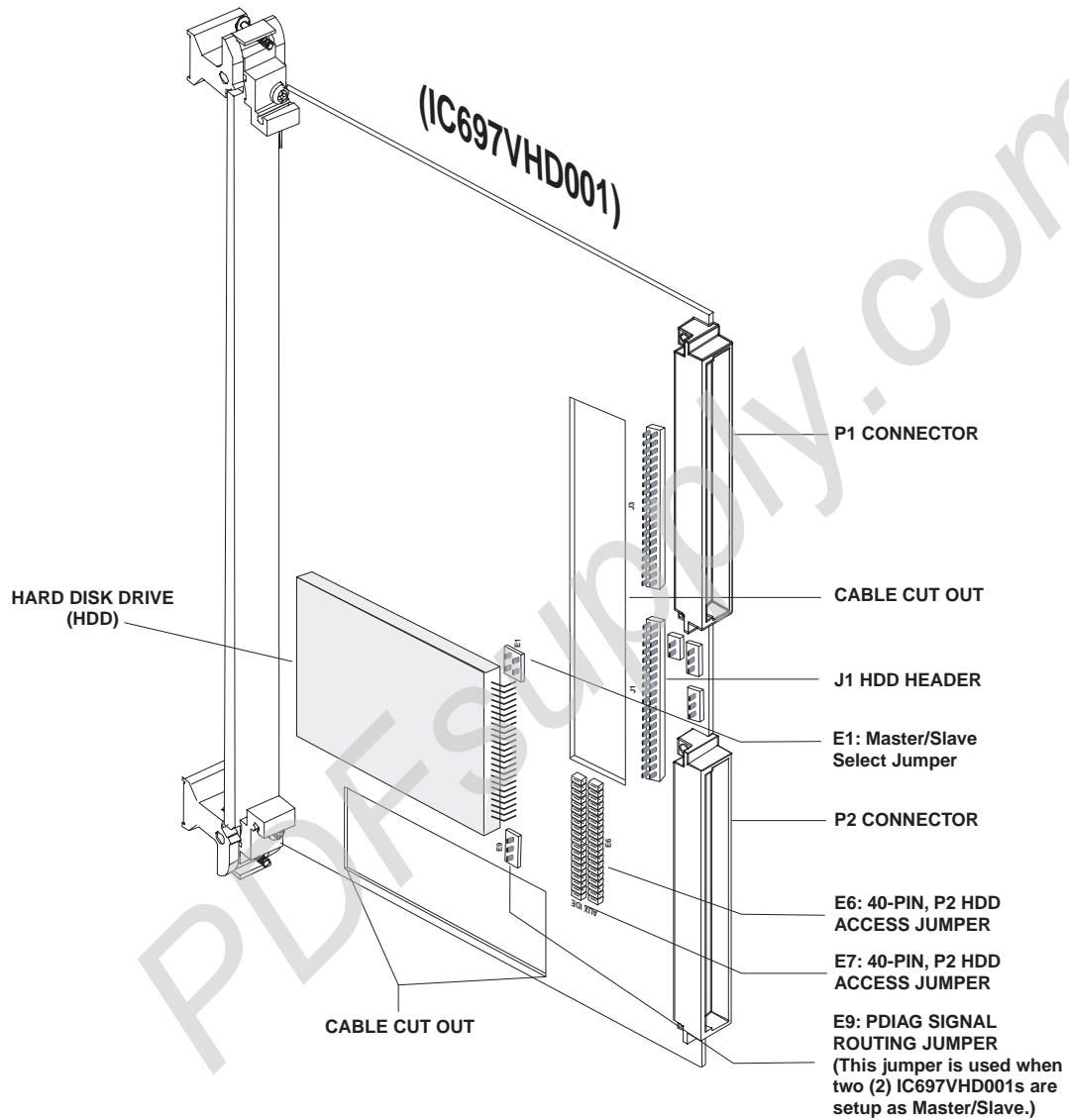

Header J1

Header J1 is used with the Hard Disk Drive (HDD) cable to interconnect the Hard Drive and SBC. The cable is routed from the J1 header to the SBC by way of the ribbon cable cutout on the Disk Module. See Figure 1-1 on page 1-3 for location of ribbon cable cutout.

Jumper E1 (Master/Slave Select)

Jumper E1 is the HDD Master/Slave select jumper. The jumper is used to configure the Hard Disk Drive for either Master or Slave mode of operation. The default configuration sets the HDD to Master (no jumpers installed).

Hard Disk Drive Jumpers (E6 and E7)

E6 and E7 are 40-pin jumpers used to route the HDD signals to the P2 connector. Installation of the shorting plugs on E6 and E7 routes the HDD signals to the P2 connector. When the shorting plugs are omitted (not installed) the signals are routed directly to the J1 header, bypassing the P2 connector.

Jumper E9 (PDIAG Signal Routing)

Jumper E9 is used in conjunction with jumper E1 (Master/Slave Select). Jumper E9 routes the PDIAG signal to the backplane when two IC697VHD001s are setup as master and slave. To route the PDIAG signal to the backplane, jumper pins 2 and 3. When using jumper E9, ensure that jumper E1 is set as either master or slave. The default configuration for jumper E9 is pins 1 and 2 jumpered.

Cable Cutouts

The Disk Module has rectangular cutout areas designed to route the cables from the FDD and HDD to the SBC. The cables are passed through the cutouts on the component side of the Disk Module to the solder side of the board for connection to the SBC.

Hard Disk Drive (J1) Header

Header J1 is used to interconnect the HDD when the cables are routed directly to the SBC, bypassing the P2 connector.

Hard Disk Drive (J1) Header and Pinout

J1 is used to connect the HDD directly to the SBC using standard ribbon cables. Figure 1-2 below illustrates the Header, while Table 1-1 represents the Header pinout.

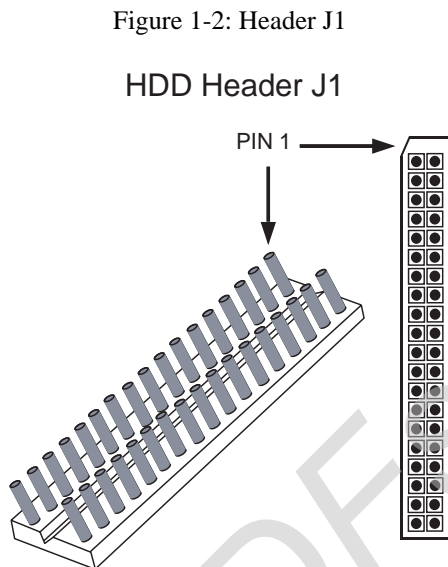

Table 1-1: HDD Header J1 Pinout

Pin No.	Signal	Pin No.	Signal
1	Reset Drive	2	Signal Ground
3	Bidirectional Data 07	4	Bidirectional Data 08
5	Bidirectional Data 06	6	Bidirectional Data 09
7	Bidirectional Data 05	8	Bidirectional Data 10
9	Bidirectional Data 04	10	Bidirectional Data 11
11	Bidirectional Data 03	12	Bidirectional Data 12
13	Bidirectional Data 02	14	Bidirectional Data 13
15	Bidirectional Data 01	16	Bidirectional Data 14
17	Bidirectional Data 00	18	Bidirectional Data 15
19	Signal Ground	20	Unused, Keying Position
21	Reserved	22	Signal Ground
23	Write Strode	24	Signal Ground
25	Read Strode	26	Signal Ground
27	Reserved	28	Address Latch Enable
29	Reserved	30	Signal Ground
31	Interrupt Request #14	32	16-bit Data Word Size
33	Address Line #1	34	Diagnostic Test Passed
35	Address Line #0	36	Address Line #2
37	Chip Select #0	38	Chip Select #1
39	Slave/Activity Status	40	Signal Ground

Note

Ensure that the red edge of the hard drive cables correspond to pin 1 of the floppy and hard drive connectors on the VMEbus-based CPU. For example, Figure 1-3 on page 1-6 and Figure 1-4 above illustrate the location of pin 1 on the floppy and hard drive connectors.

Master/Slave Select Jumper E1

Jumper E1 is the Master/Slave Select jumper. E1 is used to configure the Hard Disk Drive as either master or slave. The default configuration for jumper E1 is set to master (no jumpers installed). Refer to the HDD manufacturer's documentation for the proper configuration for slave mode. Figure 1-3 below illustrates the location and configuration of the Master/Slave Select Jumper E1.

Figure 1-3: Location of HDD Master/Slave Select Jumpers

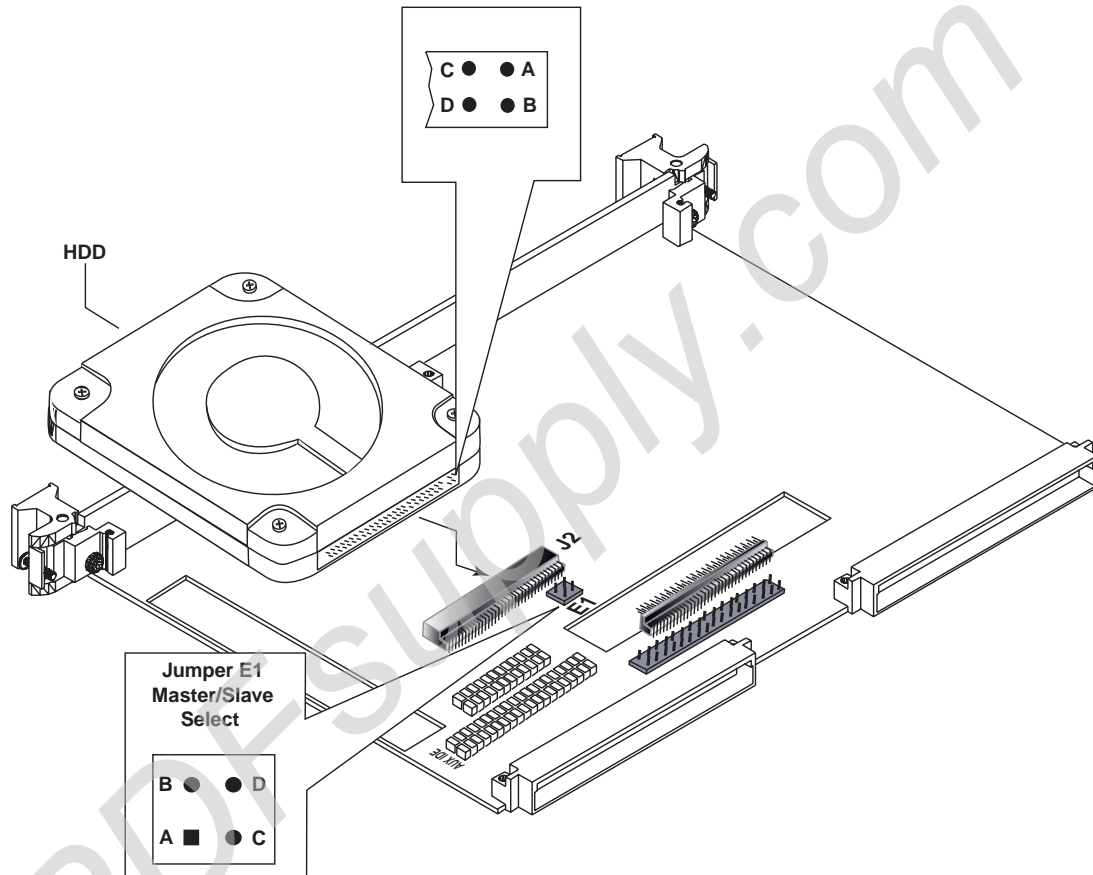

VMEbus Backplane Connectors

The Disk Module uses the standard VMEbus P1 and P2 connectors. The user-defined pins on P2 provide the signal interface for the HDD. Table 1-3 below provides the pin-out, and Figure 1-4 illustrates the connector layout and location of pin 1.

P1 Connector and Pin-out

Figure 1-4: P1 Connector

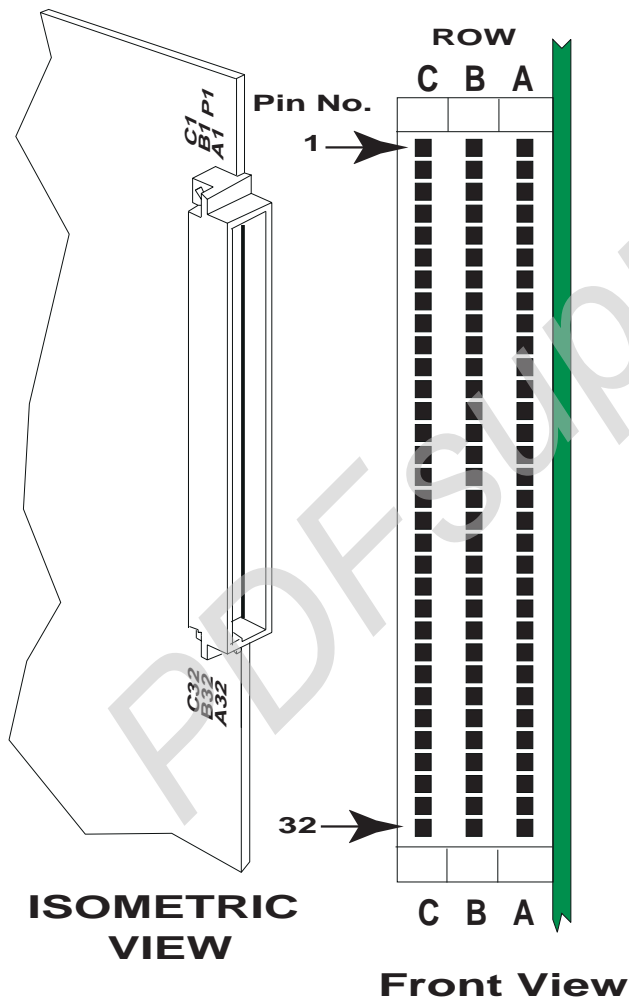

Table 1-3: P1 Connector Pin-out

Pin No.	Row C	Row B	Row A
1	N/C	N/C	N/C
2	N/C	N/C	N/C
3	N/C	N/C	N/C
4	N/C	BG0OUT*	N/C
5	N/C	BG0IN*	N/C
6	N/C	BG1OUT*	N/C
7	N/C	BG1IN*	N/C
8	N/C	BG2OUT*	N/C
9	GND	BG2IN*	GND
10	N/C	BG3OUT*	N/C
11	N/C	BG3IN*	GND
12	N/C	N/C	N/C
13	N/C	N/C	N/C
14	N/C	N/C	N/C
15	N/C	N/C	GND
16	N/C	N/C	N/C
17	N/C	N/C	GND
18	N/C	N/C	N/C
19	N/C	N/C	GND
20	N/C	GND	N/C
21	N/C	N/C	IACKOUT*
22	N/C	N/C	IACKIN*
23	N/C	GND	N/C
24	N/C	N/C	N/C
25	N/C	N/C	N/C
26	N/C	N/C	N/C
27	N/C	N/C	N/C
28	N/C	N/C	N/C
29	N/C	N/C	N/C
30	N/C	N/C	N/C
31	N/C	N/C	N/C
32	+5V	+5V	+5V

P2 Connector and Pin-out

Figure 1-5: P2 Connector

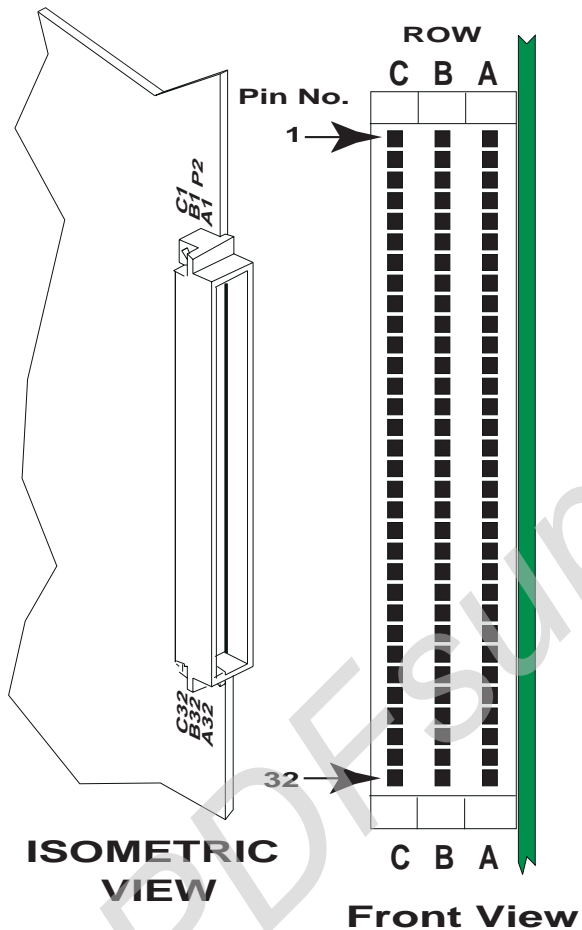

Table 1-4: P2 Connector Pin-out

Pin No.	Row C	Row B	Row A
1	Reset*	+5V	GND
2	DD7	GND	DD8
3	DD6	N/C	DD9
4	DD5	N/C	DD10
5	N/C	BG0IN*	N/C
6	N/C	BG1OUT*	N/C
7	N/C	BG1IN*	N/C
8	N/C	BG2OUT*	N/C
9	GND	BG2IN*	GND
10	N/C	BG3OUT*	N/C
11	N/C	BG3IN*	GND
12	N/C	N/C	N/C
13	N/C	N/C	N/C
14	N/C	N/C	N/C
15	N/C	N/C	GND
16	N/C	N/C	N/C
17	N/C	N/C	GND
18	N/C	N/C	N/C
19	N/C	N/C	GND
20	N/C	GND	N/C
21	N/C	N/C	IACKOUT*
22	N/C	N/C	IACKIN*
23	N/C	GND	N/C
24	N/C	N/C	N/C
25	N/C	N/C	N/C
26	N/C	N/C	N/C
27	N/C	N/C	N/C
28	N/C	N/C	N/C
29	N/C	N/C	N/C
30	N/C	N/C	N/C
31	N/C	N/C	N/C
32	+5V	+5V	+5V

SBC Board Compatibility

GE Fanuc offers single-slot Single Board Computers (SBC) that support HDD signal access through the P2 backplane connector.

Warning

Care should be taken when installing the P2 access cable. Misaligning pin 1 of the connector or connection with the wrong slot could result in a malfunction or damage to the hardware. Ensure proper pin alignment when installing the P2 access cable. GE Fanuc recommends the use of shrouded P2 backplane connectors, to facilitate the proper installation of the P2 access cable (see Figure 1-6 below).

Figure 1-6: VMEbus shrouded Backplane Connectors

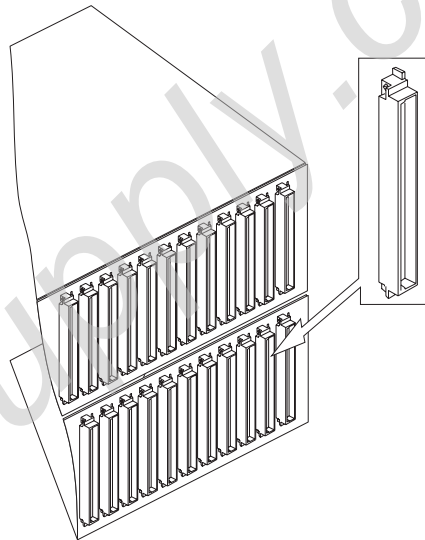

P2 Access Cable Configuration

Jumper shunts installed on headers E6 and E7 route the HDD signals to the P2 backplane connector. To connect the Disk Module with the SBC, use a P2 access cable. The P2 access cable configuration allows you to remove and install boards without disturbing the cable connections (with the exception of front panel cabling to the SBC).

If your application requires a cable other than the one supplied with the Disk Module, contact GE Fanuc Customer Service for availability and types of cables to fit your need. The P2 access cable is compatible with all VMEbus backplanes. It can also be used on VME64 backplanes.

Figure 1-7 on page 1-11 illustrates a typical connection of the Disk Module using the P2 access cable configuration.

64-Conductor P2 Access Cable Installation Procedure

1. Ensure that the configuration of the SBC is appropriate for P2 access of HDD signals. Refer to the SBC product manual for this type of configuration.
2. Ensure that the jumper shunts are installed onto E6 and E7. See Figure 1-1 on page 1-3 for location of jumpers.
3. Install the SBC and the Disk Module into the desired slots of the VMEbus chassis.
4. From the rear of the chassis, install the P2 cable onto the rear P2 shrouded backplane connectors of the VMEbus chassis. The cable should correspond to the location of the SBC and Disk Module.
5. Installation is complete, power-up the chassis.

Caution

Ensure proper pin alignment when installing the P2 access cable. GE Fanuc recommends the use of shrouded P2 backplane connectors to facilitate the proper installation of the P2 access cable (see Figure 1-6 on page 1-9). When installing the P2 access cable on a VME64 backplane, ensure that only the center three rows of the VME64 shrouded P2 connector is used.

Figure 1-7: Typical Connection using the P2 Backplane Connectors and Cable Assembly

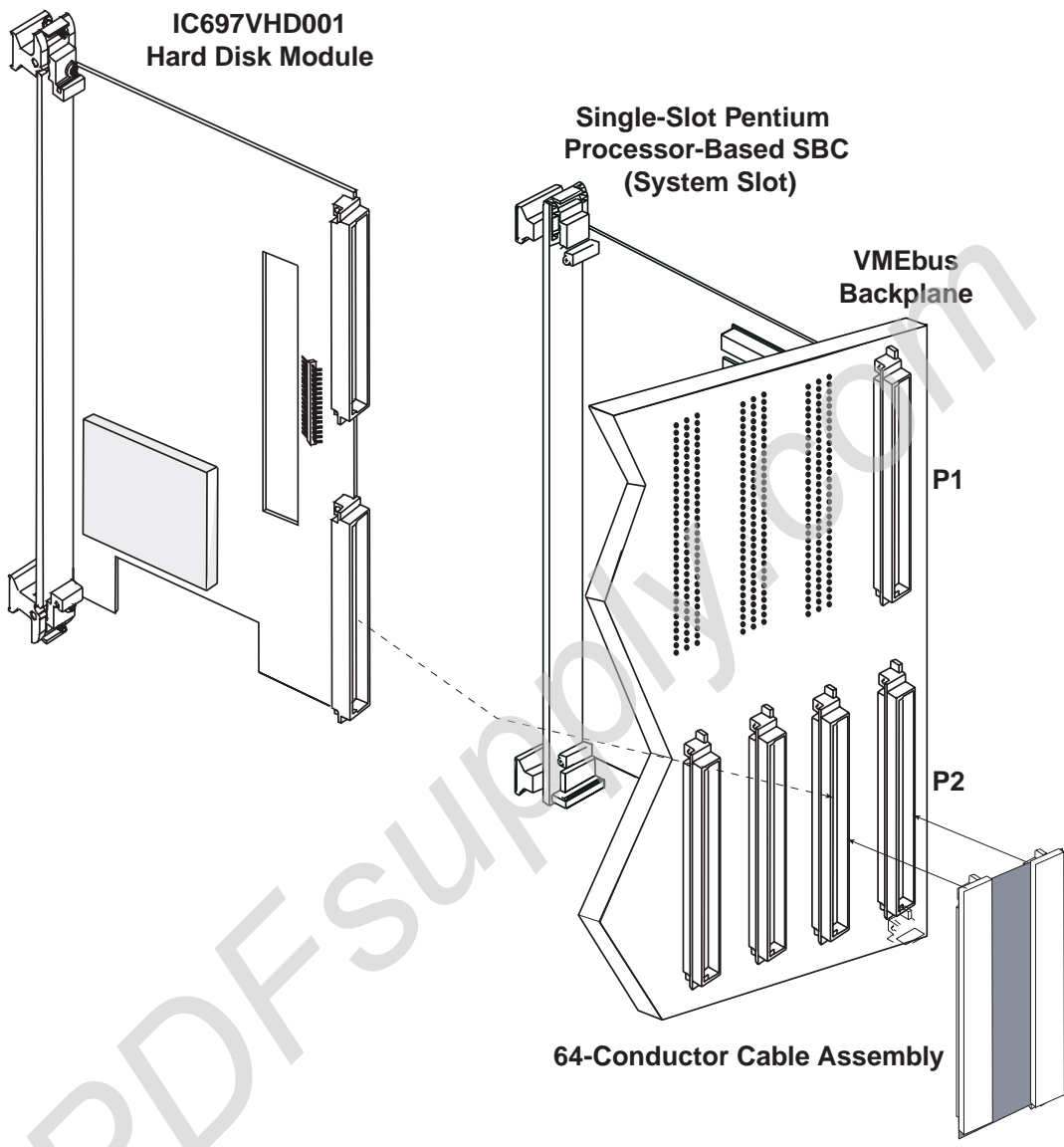
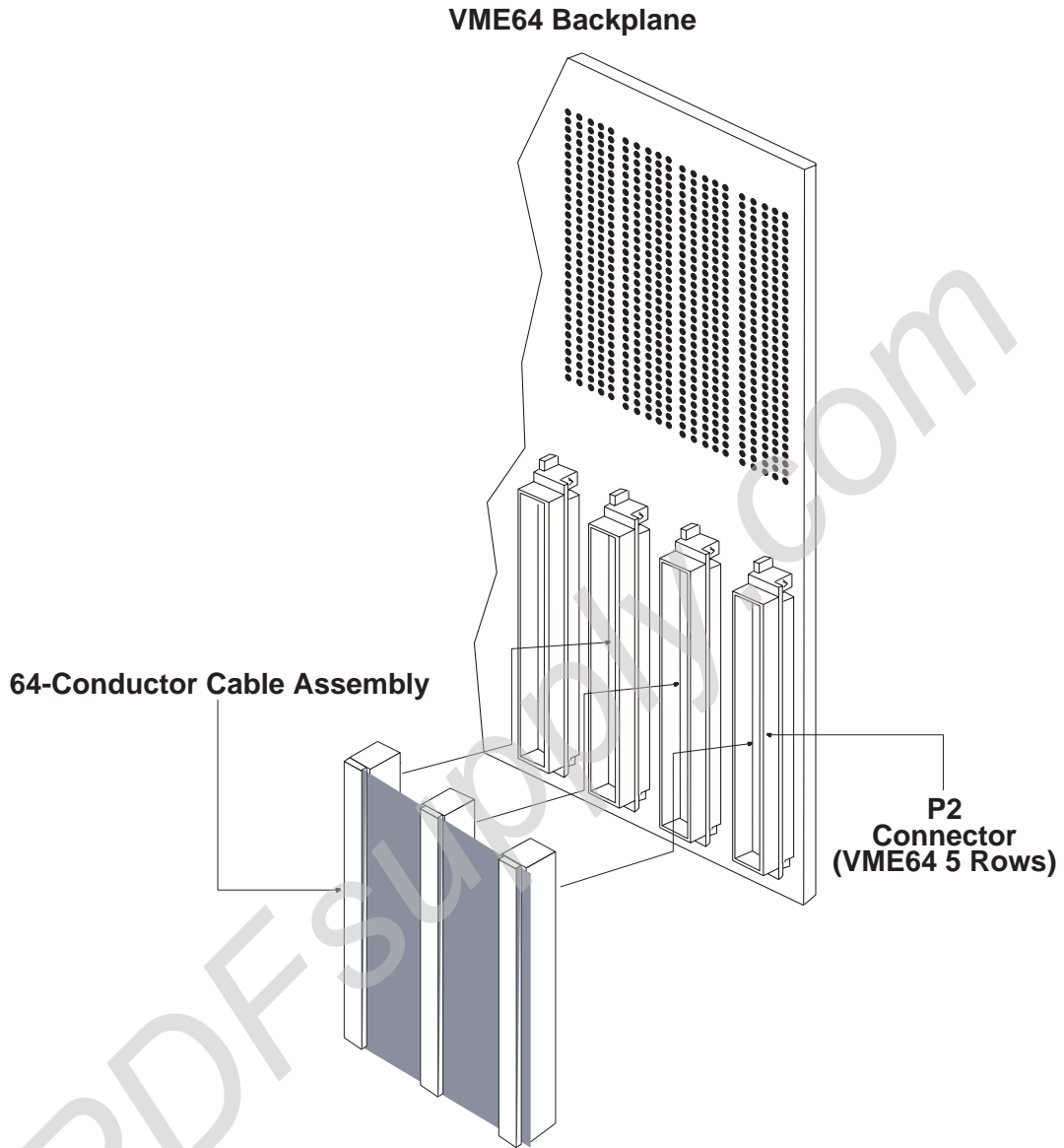

Figure 1-8: VME64 Backplane with the P2 Access Cable



Note

Ensure that ONLY the three center rows of pins are used when the P2 Access Cable Assembly is used with the VME64 chassis.

P2 Access Cable Assemblies

Figure 1-9: 2 Connector P2 Access Cable

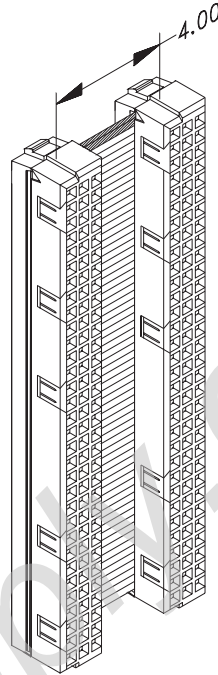

Figure 1-10: 3 Connector P2 Access Cable

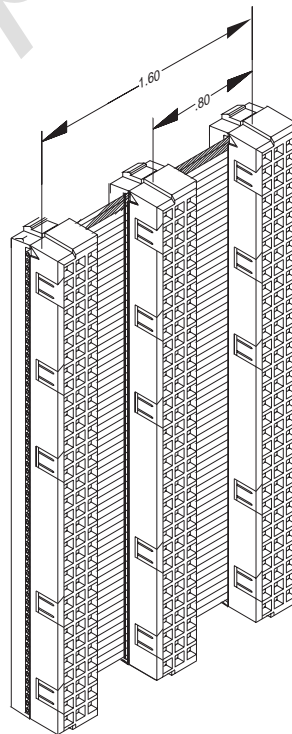

Figure 1-11: 3 Connector, Longer Cable P2 Access Cable

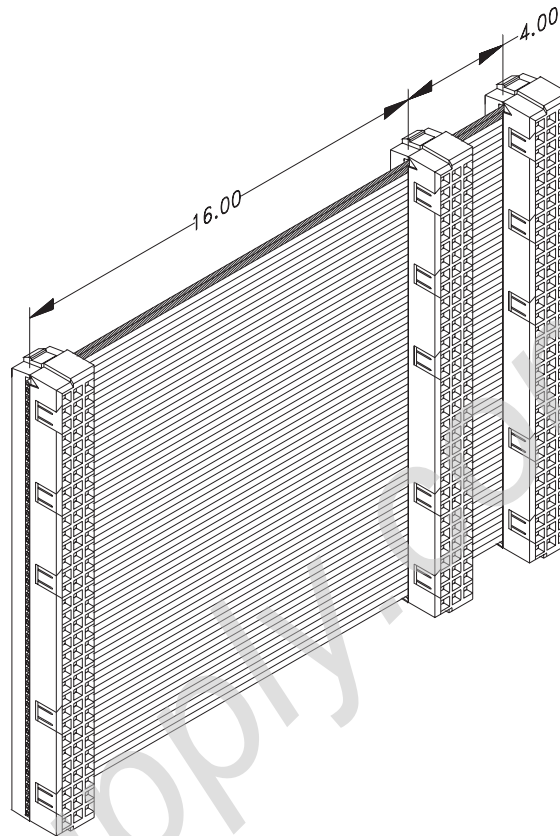
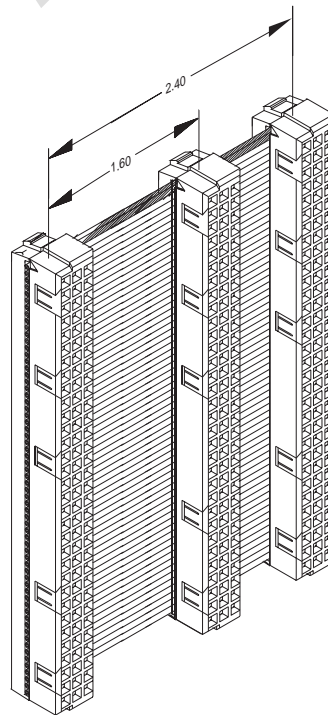

Figure 1-12: 3 Connector, Shorter Cable P2 Access Cable



Safety Summary

The following general safety precautions must be observed during all phases of this operation, service, and repair of this product. Failure to comply with these precautions or with specific warnings elsewhere in this manual violates safety standards of design, manufacture, and intended use of this product. GE Fanuc assumes no liability for the customer's failure to comply with these requirements.

Ground the System

To minimize shock hazard, the chassis and system cabinet must be connected to an electrical ground. A three-conductor AC power cable should be used. The power cable must either be plugged into an approved three-contact electrical outlet or used with a three-contact to two-contact adapter with the grounding wire (green) firmly connected to an electrical ground (safety ground) at the power outlet.

Do Not Operate in an Explosive Atmosphere

Do not operate the system in the presence of flammable gases or fumes. Operation of any electrical system in such an environment constitutes a definite safety hazard.

Keep Away from Live Circuits

Operating personnel must not remove product covers. Component replacement and internal adjustments must be made by qualified maintenance personnel. Do not replace components with power cable connected. Under certain conditions, dangerous voltages may exist even with the power cable removed. To avoid injuries, always disconnect power and discharge circuits before touching them.

Do Not Service or Adjust Alone

Do not attempt internal service or adjustment unless another person, capable of rendering first aid and resuscitation, is present.

Do Not Substitute Parts or Modify System

Because of the danger of introducing additional hazards, do not install substitute parts or perform any unauthorized modification to the product. Return the product to GE Fanuc for service and repair to ensure that safety features are maintained.

This chapter provides information relative to the care and maintenance of the Disk Module product.

If the product malfunctions, verify the following:

- Software
- System configuration
- Electrical connections
- Jumper or configuration settings
- Boards fully inserted into their proper connector location
- Connector pins are clean and free from contamination
- No components of adjacent boards are disturbed when inserting or removing the board from the VMEbus card cage
- Quality of cables and I/O connections

User level repairs are not recommended. Contact your authorized GE Fanuc distributor for a Return Material Authorization (RMA) Number. **This RMA Number must be obtained prior to any return.**