

6246BP10820

New In Stock!

ABB

<http://www.pdfsupply.com/automation/abb/623-624-series/6246BP10820>

623-624-series

1-919-535-3180

Electronic Assembly for 6246BP10810

www.pdfsupply.com

Email: sales@pdfsupply.com

Specifications

Block Type: 115VAC/125VDC Isolated I/O Block: Terminal Assembly Only: Electronics Assembly Only: 115VAC/125VDC Isolated I/O Block, No Failed Switch: Terminal Assembly Only: Electronics Assembly Only:	8 ckt isolated input/output in 4 isolated pairs IC660BBS102, replaces IC660BBS100 IC660TSS100 IC660EBS100 IC660BBS103, replaces IC660BBS101 IC660TSS100 IC660EBS101																																										
Size (height x width x depth): Weight: LED's (I/O Block): LED's (each circuit): Block to Block Isolation: Heat Dissipation:	8.83" (22.44cm) x 3.50" (8.89cm) x 3.94" x (10.00cm) 4 lbs. (1.8 kg) Unit OK, I/O Enabled On logic side of switch 1500 V 16.8W max. with 8 inputs on, 45.6W max. with 8 outputs at 2 amps																																										
Operating Temperature Storage Temperature Humidity Vibration	-0 to +60C (32 to +140F) -40 C (-40 to +212F) 5% to 95% (non-condensing) 5-10 Hz 0.2" (5.08mm) displacement, 10-200 Hz at 1G																																										
Required control power (block only): Operating voltage (four sources): Frequency/ripple: Power supply dropout time:	8 Watts maximum <u>93-132 VAC</u> 47-63 Hz 1 cycle <u>105-132 VDC</u> 10% max. ripple 10mS																																										
Input Characteristics: Non-tristate input, OFF state: Minimum voltage across input device (IN to H) Maximum leakage through input device Non-tristate input, ON state: Maximum voltage across input device (IN to H) Maximum switch current threshold Tristate input: OFF, acceptable voltage across input device (IN to H) ON, maximum voltage across input device (IN to H) Input load network: Resistor to N Capacitor to H: for blocks BBS100 and BBS101 Capacitor to H: for blocks BBS102 and BBS103 Input processing time (typical) Selectable input filter times Input diagnostics	<table border="0"> <thead> <tr> <th><u>For AC</u></th> <th><u>For DC</u></th> </tr> </thead> <tbody> <tr> <td>60 VRMS</td> <td>70 VDC</td> </tr> <tr> <td>1 mA</td> <td>2 mA</td> </tr> <tr> <td>20 VRMS</td> <td>35 VDC</td> </tr> <tr> <td>6 mA RMS</td> <td>5 mA</td> </tr> <tr> <td>16 VRMS-40 VRMS</td> <td>16 VDC-35 VDC</td> </tr> <tr> <td>4 VRMS</td> <td>3.5 VDC</td> </tr> <tr> <td>13K ohms</td> <td>13K ohms</td> </tr> <tr> <td>.22 µf</td> <td>.22 µf</td> </tr> <tr> <td>.1 µf</td> <td>.1 µf</td> </tr> <tr> <td>2mS + filter</td> <td>0.8mS + filter</td> </tr> <tr> <td colspan="2">10 to 100mS in 10mS increments</td> </tr> <tr> <td colspan="2">Open Wire, Overtemperature, Loss of I/O Power, Failed Switch</td> </tr> </tbody> </table>	<u>For AC</u>	<u>For DC</u>	60 VRMS	70 VDC	1 mA	2 mA	20 VRMS	35 VDC	6 mA RMS	5 mA	16 VRMS-40 VRMS	16 VDC-35 VDC	4 VRMS	3.5 VDC	13K ohms	13K ohms	.22 µf	.22 µf	.1 µf	.1 µf	2mS + filter	0.8mS + filter	10 to 100mS in 10mS increments		Open Wire, Overtemperature, Loss of I/O Power, Failed Switch																	
<u>For AC</u>	<u>For DC</u>																																										
60 VRMS	70 VDC																																										
1 mA	2 mA																																										
20 VRMS	35 VDC																																										
6 mA RMS	5 mA																																										
16 VRMS-40 VRMS	16 VDC-35 VDC																																										
4 VRMS	3.5 VDC																																										
13K ohms	13K ohms																																										
.22 µf	.22 µf																																										
.1 µf	.1 µf																																										
2mS + filter	0.8mS + filter																																										
10 to 100mS in 10mS increments																																											
Open Wire, Overtemperature, Loss of I/O Power, Failed Switch																																											
Output Characteristics: Output current (steady state) Maximum inrush current Output Leakage: Current at 0 volt output: for blocks BBS102 and 103 Current at 0 volt output: for blocks BBS100 and 101 Voltage at open output: for blocks BBS102 and 103 Voltage at open output: for blocks BBS100 and 101 Output switch (OFF to ON/ON to OFF) Rated switching frequency at maximum inrush Turn-on delay (maximum) Voltage drop (at 2 amps) Voltage drop (at 20 amps inrush) Minimum load (No Load disabled) Resistive: for blocks BBS102 and BBS103 Resistive: for blocks BBS100 and BBS101 Inductive: for blocks BBS102 and BBS103 Inductive: for blocks BBS100 and BBS101 No Load enabled threshold Maximum block output current Fusing Output diagnostics	<table border="0"> <thead> <tr> <th><u>For AC</u></th> <th><u>For DC</u></th> </tr> </thead> <tbody> <tr> <td>2 amps</td> <td>2 amps resistive 9 (1 amp inductive*)</td> </tr> <tr> <td>25 amps (2 cycles)</td> <td>25 amps (10mS peak)</td> </tr> <tr> <td>7 mA</td> <td>2 mA</td> </tr> <tr> <td>13 mA</td> <td>2 mA</td> </tr> <tr> <td>65 volts</td> <td>40 volts</td> </tr> <tr> <td>95 volts</td> <td>40 volts</td> </tr> <tr> <td>Zero crossing</td> <td>—</td> </tr> <tr> <td>Once per second</td> <td>Once per second</td> </tr> <tr> <td>0.5 Hz + 1mS</td> <td>1mS</td> </tr> <tr> <td>2.5 volts</td> <td>2.5 volts</td> </tr> <tr> <td>10 volts</td> <td>10 volts</td> </tr> <tr> <td>25 mA</td> <td>10 mA</td> </tr> <tr> <td>30 mA</td> <td>10 mA</td> </tr> <tr> <td>40 mA</td> <td>10 mA</td> </tr> <tr> <td>100 mA</td> <td>10 mA</td> </tr> <tr> <td>50 mA</td> <td>50 mA</td> </tr> <tr> <td colspan="2">15 amps at 35 C, 7.5 amps at 60C</td> </tr> <tr> <td colspan="2">Internal electronic short circuit trip.</td> </tr> <tr> <td colspan="2">100ms (AC), 10ms (DC) long time trip</td> </tr> <tr> <td colspan="2">Short Circuit, Overload, No Load, Overtemp., Loss of I/O Power. Also, for blocks BBS100 and BBS 102 only: Failed Switch</td> </tr> </tbody> </table>	<u>For AC</u>	<u>For DC</u>	2 amps	2 amps resistive 9 (1 amp inductive*)	25 amps (2 cycles)	25 amps (10mS peak)	7 mA	2 mA	13 mA	2 mA	65 volts	40 volts	95 volts	40 volts	Zero crossing	—	Once per second	Once per second	0.5 Hz + 1mS	1mS	2.5 volts	2.5 volts	10 volts	10 volts	25 mA	10 mA	30 mA	10 mA	40 mA	10 mA	100 mA	10 mA	50 mA	50 mA	15 amps at 35 C, 7.5 amps at 60C		Internal electronic short circuit trip.		100ms (AC), 10ms (DC) long time trip		Short Circuit, Overload, No Load, Overtemp., Loss of I/O Power. Also, for blocks BBS100 and BBS 102 only: Failed Switch	
<u>For AC</u>	<u>For DC</u>																																										
2 amps	2 amps resistive 9 (1 amp inductive*)																																										
25 amps (2 cycles)	25 amps (10mS peak)																																										
7 mA	2 mA																																										
13 mA	2 mA																																										
65 volts	40 volts																																										
95 volts	40 volts																																										
Zero crossing	—																																										
Once per second	Once per second																																										
0.5 Hz + 1mS	1mS																																										
2.5 volts	2.5 volts																																										
10 volts	10 volts																																										
25 mA	10 mA																																										
30 mA	10 mA																																										
40 mA	10 mA																																										
100 mA	10 mA																																										
50 mA	50 mA																																										
15 amps at 35 C, 7.5 amps at 60C																																											
Internal electronic short circuit trip.																																											
100ms (AC), 10ms (DC) long time trip																																											
Short Circuit, Overload, No Load, Overtemp., Loss of I/O Power. Also, for blocks BBS100 and BBS 102 only: Failed Switch																																											

* DC inductive load rating is 2 amps with external flyback diode or other coil suppression.

Compatibility

Hand-held Monitor: These blocks are fully compatible with a Hand-held Monitor identified by catalog number IC660HHM501. They may also be used with HHM500. HHM501 is required to change baud rate configuration, or to configure the block for redundancy.

Bus Controller: The blocks may be used with any GE Fanuc Genius bus controller, PCIM or QBIM.

I/O Blocks: These blocks are backward-compatible with previous block versions (IC660CBS100, IC660BBS100, and IC660BBS101). They may be used as replacements for earlier versions. However, their Terminal Assemblies are not backward-compatible, as explained below.

Electronics Assembly: Electronics Assembly IC660EBS100H may be used to replace any Electronics Assembly IC660ELS100 or IC660EBS100. Electronics Assembly IC660EBS101C may be used to replace any version IC660ELS100, EBS100, or EBS101. These Electronics Assemblies draw lower leakage current (7mA) than earlier versions (which drew 13mA).

Terminal Assembly: The Terminal Assembly for these blocks (IC660TSS100E) is *not compatible with some earlier versions of their Electronics Assemblies* (IC660EBS100A to G, or IC660EBS101A or B). If Terminal Assembly IC660TSS100E will be used to replace an earlier version of the Terminal Assembly, it will also be necessary to upgrade the Electronics Assembly. This can be done by replacing the entire Electronics Assembly with version IC660EBS100H or IC660EBS101C, or later. It can also be done by upgrading the Electronics Assembly firmware using one of these update kits:

44A286357-G06 (with Failed Switch Diagnostics)

44A286390-G03 (without Failed Switch Diagnostics)

Block Operation

An Isolated block has four isolated groups of two I/O circuits, each rated to operate at a nominal 115VAC or 125VDC.

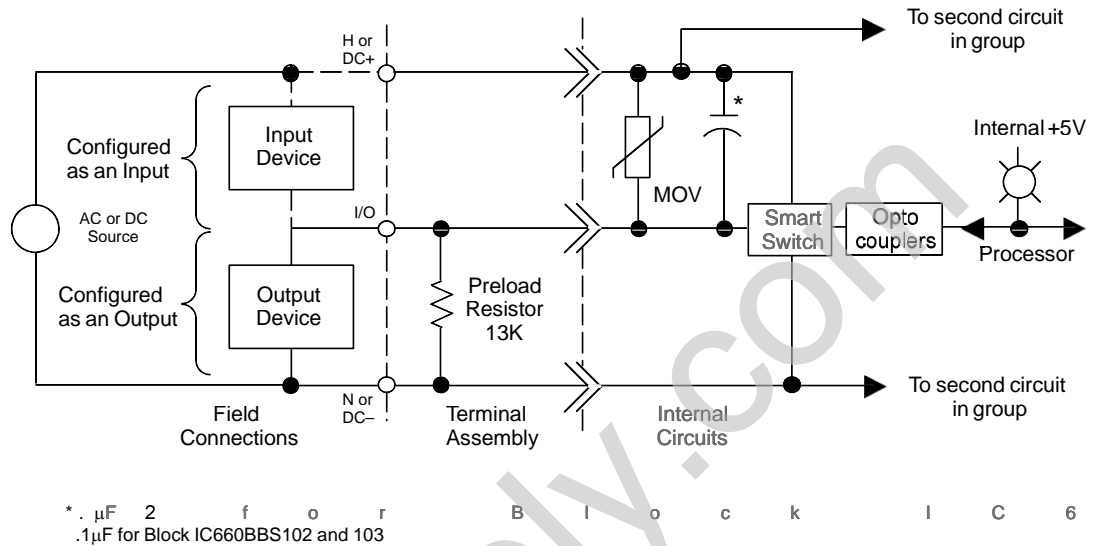

Circuit LEDs

Each circuit has its own LED. If the circuit is configured as an input, the LED indicates the presence of threshold voltage at the input terminal. If the circuit is configured as an output, the LED indicates the state commanded by the CPU.

Inputs and Outputs

An Isolated Block can be configured as an inputs-only, outputs-only, or combination block. For a new block, the default is inputs-only. Regardless, the block always broadcasts one byte of data each bus scan, and accepts one byte of data each bus scan.

If the block is configured as a combination block, circuits can be any mix of inputs and/or outputs. The block will use 8 input references and 8 output references. The actual state of each output will be returned to the CPU in the corresponding input reference location. The CPU can monitor the feedback state to verify (after an appropriate delay) that the output switching device has operated properly and that the load has the proper voltage and current applied.

If the block is configured as an inputs-only block, all circuits must be regular inputs or tristate inputs. The block will use 8 input references and NO output references.

If the block is configured as an outputs-only block, all circuits must be outputs; no feedback analysis will be performed. The block will use 8 output references and NO input references.

Appendix B shows reference usage for a Series 90, Series Six, or Series Five PLC.

Input Data Format

The block broadcasts 1 byte of input data each bus scan.

Byte #	Description
0	Inputs 1 – 8 (input 1 in bit 0)

Output Data Format

The block receives 1 byte of output data from the bus controller each bus scan.

Byte #	Description
0	Outputs 1 – 8 (output 1 in bit 0)

Hand-held Monitor I/O Display

The Hand-held Monitor displays the I/O types (line 3) and current states (line 4) of all circuits on the Monitor Block screen.

REF				1-		8	0
1	2	3	4	5	6	7	8
0	0	0	0	0	0	0	0
1	1	0	1	0	1	0	0

Individual circuits are displayed on the Monitor/Control Reference screen (which also shows a circuit's fault and force status).

Diagnosics

115 VAC/125 VDC Isolated I/O blocks perform the following diagnostic checks. The block reports all faults to the Hand-held Monitor, and takes appropriate corrective action.

Individual circuits can be configured not to send diagnostic messages to the CPU if a fault occurs. If the CPU requests diagnostic information from the block using Read Diagnostic datagrams, the block returns current diagnostics for all circuits, including any with CPU fault reporting disabled.

Loss of I/O Power Diagnostic

An Isolated I/O block operates as long as power is supplied to terminals 5 and 6. The Loss of I/O Power diagnostic, which is unique to these blocks, indicates that one pair of circuits is disconnected from field power.

If either circuit of the pair is an input, the block sets it to 0. If either circuit is an output, the block turns it off. The block automatically sends a Loss of I/O Power diagnostic message to the Hand-held Monitor. However, the message is not sent to the CPU unless the block is Pulse Tested. The Unit OK LED does *not* blink. When I/O power is restored, the circuits begin operating as soon as power reaches the minimum level.

If I/O power to the block itself is lost, the block cannot send diagnostic messages to the CPU. The bus controller responds as it would to any other loss of block condition.

Overtemperature Diagnostic

Each circuit has a built-in thermal sensor. If the block's internal temperature exceeds 100C, the block sends an OVERTEMPERATURE message and turns off the circuit to protect its internal electronics. This diagnostic is always performed for both inputs and outputs.

Short Circuit Diagnostic

Automatic output diagnostic. Output circuits are always protected by a short circuit level sensor at the switching device. An output will turn off within several microseconds after the instantaneous current exceeds 25 amps at turn-on, or 15 amps after 2 cycles AC or 10mS for DC. The block will try to restart the load; if several attempts are unsuccessful, the output circuit is forced off and the block sends a SHORT CIRCUIT message. To restore normal operation, the cause of the current surge must be removed, then the diagnostic must be cleared from the HHM or the CPU.

Failed Switch Diagnostic

BOTH Isolated block versions will report Failed Switch diagnostics for internal faults independent of the output state, on both input and output-configured circuits. Examples include loss of communications with the block's internal microprocessor and some internal power supply faults.

Block version IC660BBS100 will also report this diagnostic if an output's switch state is not the same as its commanded state. The block sends a Failed Switch message identifying the failed circuit. The logic state of the circuit is set to OFF.

When an output fault occurs, the actual condition of the output switch is not known. If the output switch has failed shorted (or closed), current flow is not interrupted when the block forces the output state OFF. Action external to the block must be taken to remedy the problem. The FAILED SWITCH message can alert personnel or cause program logic to be activated, possibly shutting off power to the block, I/O section, or process.

Note

False Failed Switch diagnostics may be reported if an external device like a manual switch is wired in parallel with an output. Even if fault reporting for the circuit is disabled, it will be necessary to clear each Failed Switch fault detected by the block. If the application requires such a configuration, block version IC660BBS101 (no Failed Switch diagnostic) should be used.

Open Wire Diagnostic

The block automatically performs this diagnostic on any circuit configured as a tristate input. It will detect an electrical (not mechanical) malfunction. In addition to being configured as a tristate input, the circuit must have a 5.1K ohm, 1/2 Watt or larger non-inductive resistor installed across the actual dry contacts of the input device (such as across the field device terminals).

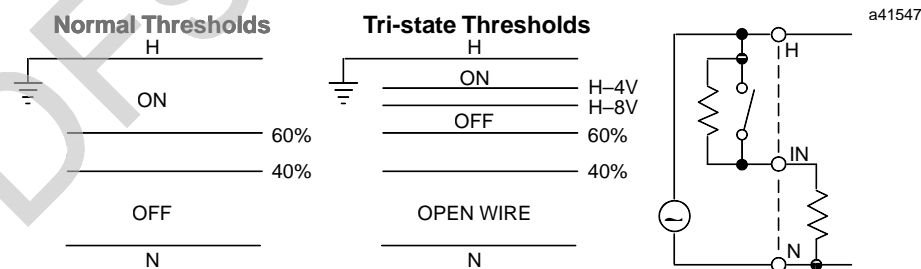

With the switch closed (ON state), the circuit senses the low source impedance. With the switch open (OFF state), the circuit senses the added resistance. If a wire is broken, cut or removed, impedance becomes very high. The block will transmit 0 as the state of the input, and send an OPEN WIRE message.

Devices such as photo-sensors, electronic high-speed counters, instrumentation, fiber optic sensors, and similar electronic devices cannot be monitored for Open Wire conditions. Such devices should be set up as standard, not tristate, inputs.

GE offers compatible input devices including a 5.1K ohm monitoring resistor with its line of General Purpose Control sensor devices.

No Load Diagnostic

This optional diagnostic can be enabled or disabled for individual outputs.

For a new block, outputs are configured to report No-Load conditions. In this configuration, energizing the output activates a no-load current level. If the load does not continuously draw 50mA from the output circuit, the block sends a NO LOAD message. Because this diagnostic monitors both current and voltage, a No Load condition may cause an HHM monitoring an operating block to display 0 for the circuit although there is voltage at the output and the circuit LED is on.

This diagnostic should be disabled for circuits on which very small loads (small relays, transformers, or indicating lamps) will draw less than 50mA.

Overload Shutdown

Like No-load reporting, this diagnostic is also optional for individual outputs on the block.

In addition to the protection provided by the block's built-in Short Circuit detection, Overload Shutdown provides further protection for output loads, field wiring, and switching devices.

AC Output Overload

For an AC output, overload occurs if a load exceeds 2.8 amps (2.0 amps RMS) continuously for 100mS. The block will turn the output off and send an OVERLOAD message if Overload Shutdown is enabled.

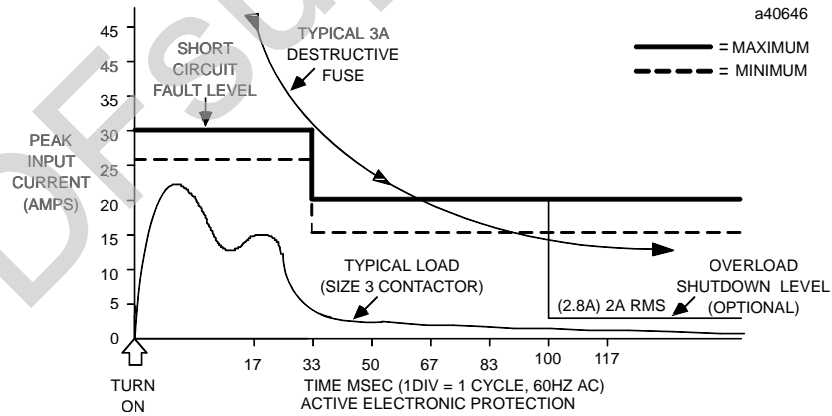

DC Output Overload

For a DC output, overload occurs if the output exceeds 2 amps continuously for 10mS after the initial 10mS turn-on period. DC circuit protection is shown below.

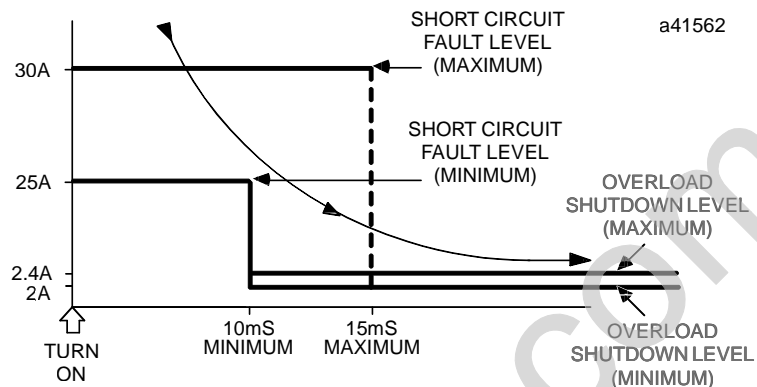

Individual outputs can be configured not to shut off at this level or send the OVERLOAD message. These restrictions apply:

1. Maximum load current: 10 amps
2. RMS Maximum duty cycle: limit duty cycle so that: (load current) x (% ON) is less than 1.0 amp.
3. Maximum ON time: 1 minute
4. Maximum total current of all outputs ON at the same time is less than 15 amps.

For example, a maximum 10 amp load can be pulsed at a 10% duty cycle, or up to 1 minute ON and 9 minutes OFF. Higher repetition rates can be used if the duty cycle is maintained. Exceeding the 10 amp limit may cause a short circuit fault to be generated. The duty cycle derating to an average of 1 amp output current and the ON time limit are necessary to avoid overheating due to the increased power dissipation in the block at these high currents. Exceeding these limits may cause an overtemperature fault.

Field Wiring

All field wiring connections to these blocks are standard screw, clamp-type terminals which can be operated with a flat or phillips-head screwdriver. Each terminal accepts one AWG #12 or two AWG #14 wires. The minimum recommended wire size is AWG #22. The terminals can accommodate spade or ring terminals up to 0.27 inch (6.85 mm) in width with a minimum opening for a #6 screw, and up to 0.20 inch (5.1 mm) depth from the screw center to the back barrier.

Power Connections

Up to five separate power sources can be connected to the Terminal Assembly. Circuit power and block power do not have to be the same type. Block power may be DC while circuit power is AC, or the reverse. Isolation is rated to withstand 250 volts AC or DC continuous between any group and ground, or between any two groups.

For block power, connect a 115 volt AC or 125 VDC source to the top H terminal (5). Connect neutral to the N terminal (6). All H terminals are internally bussed, as are all N terminals.

Circuit Power

Each circuit pair can have its own power supply. All circuits on an Isolated block must use either AC or DC power.

If circuit power is AC, both circuits of a pair must be wired to the same AC phase. However, different pairs of circuits can be wired to different AC phases.

Caution

If separate AC power is used for any group of circuits on a block, all power connections within the group must be wired to that same 120 VAC source.

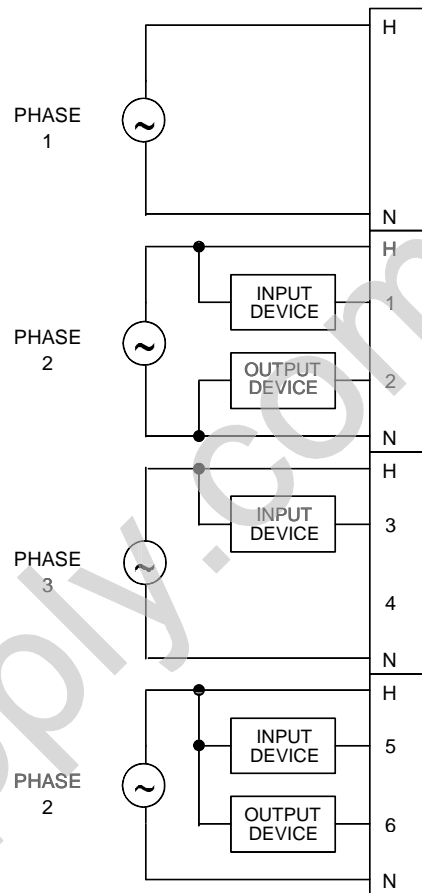

a41521

Wiring for I/O Devices

For each input device, connect one terminal to the Hot side of AC power or positive side of 125 VDC. Connect the other to the I/O block at terminal 8, 9, 12, 13, 16, 17, 20, or 21.

For each output, connect one terminal to block terminal 8, 9, 12, 13, 16, 17, 20, or 21. Connect the other to the neutral side of AC power or the negative side of 125 VDC. The block must have both sides of power connected to it.

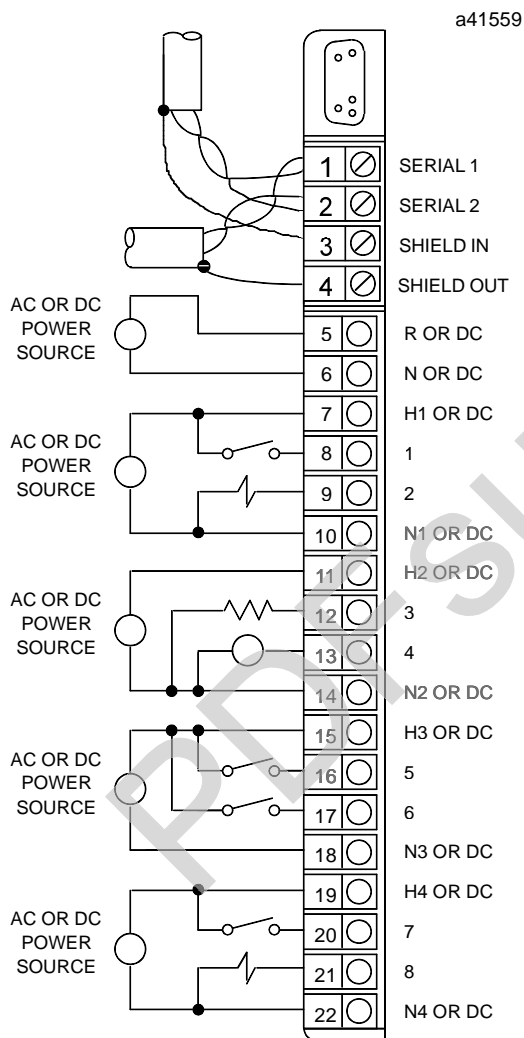

Only one wire need be run to the field device. Depending on physical layout and current loads, hot connections can be bussed together and made by one wire to the block or power source. Neutral connections can also be bussed together and made by one wire.

Wiring for Tristate Inputs

If any input circuit is configured as a tristate input, install a 5.1K ohm, 1/2 Watt or larger non-inductive resistor across the dry contacts of the input device. This added resistance is required to use the Open Wire diagnostic.

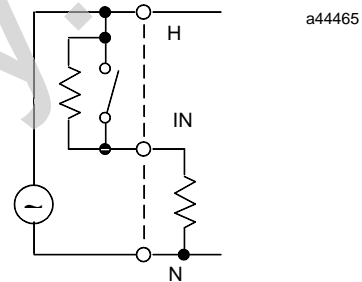

Interfacing Small Loads to an Isolated Block

If any output will drive an inductive load drawing less than 50 mA, it may be necessary to add resistance at the load. See page 2-10 for instructions.

Wiring for a Bus Switching Module

If the block will be a BSM Controller, attach the BSM like a load to circuit 1. Connect either BSM pigtail wire to terminal 8, and the other to neutral or DC- (such as terminal 10).

Block Configuration

The configurable features of a 115VAC/125VDC 8 Circuit Isolated Block are listed below. For many, the factory setting may not need to be changed.

Feature	Circuit or Block	Factory Setting	Selections
Device Number*	Block	null	0 to 31 (a number must be selected)
Reference Address*	Block	none	Depends on host CPU type
BlockI/OType*	Block	input	input, output, combination
Baud Rate*	Block	153.6 std	153.6 std, 153.6 ext, 76.8, 38.4 Kbd
AC/DCCircuitVoltage	Block	AC, DC	AC
Pulse Test for Outputs	Block	enabled	enabled, disabled
Input Filter Time	Block	20mSec	10–100mSec in 10mS steps
CircuitI/OType	Circuit	input	input, output, tristate input
Report Faults	Circuit	yes	yes, no
Hold Last State	Circuit	no	yes, no
Output Default State	Circuit	off	on, off
Report No Load	Circuit	yes	yes, no
Overload Shutdown	Circuit	yes	yes, no
BSM Present	Block	no	yes, no
BSM Controller	Block	no	yes, no
Output Default Time	Block	3 bus scans	(for bus redundancy) 2.5 sec or 10 sec
Redundancy Mode	Block	none	none, hot standby, duplex
Duplex Default State	Block	off	on, off
Configuration Protection	Block	disabled	enabled, disabled

Features with an asterisk in the table are configured from the Program Block ID screen of the Hand-held Monitor, as explained in chapter 3.

The rest of the features can be configured either using a Hand-held Monitor, or by sending a Write Configuration datagram to the block from the host.

Instructions for configuring these features using a Hand-held Monitor are given on the following pages.

Before configuration begins, the blocks features should be decided on and recorded on copies of the Configuration Worksheet printed on the next page.

115 VAC/125 VDC Isolated I/O Block Configuration Worksheet

Block _____ Location _____

Block Features:

Configuration Protected (Y/N) _____ AC/DC Circuit Voltage _____

Block Number (0–31) _____ Block Type (Input/Output/Combination) _____

Reference Address _____ through _____

Baud Rate (153.6 Kb Std/153.6 Kb Ext/76.8 Kb/38.4 Kb) _____

Pulse Test (Enabled/Disabled) _____ Input Filter Time (10–100) mS _____

Redundancy Features:

Redundancy Mode (None/Standby/Duplex) _____ Duplex Default (on/off) _____

BSM Present (Y/N) BSM Controller (Y/N) _____ Outputs Default (2.5/10 sec) _____

Circuit Features:

Ckt #	Reference Number	I/O Type (I/O/I _T *)	Report Faults (yes/no)	(output) Hold Last State (yes/no)	(output) Default State (ON/OFF)	(output) Report No Load (yes/no)	(output) Overload Shutdown (yes/no)
1	_____	_____	_____	_____	_____	_____	_____
2	_____	_____	_____	_____	_____	_____	_____
3	_____	_____	_____	_____	_____	_____	_____
4	_____	_____	_____	_____	_____	_____	_____
5	_____	_____	_____	_____	_____	_____	_____
6	_____	_____	_____	_____	_____	_____	_____
7	_____	_____	_____	_____	_____	_____	_____
8	_____	_____	_____	_____	_____	_____	_____

* I_T (Tristate Input) must have 5.1K Ω resistor across dry contacts of input device

Pulse Test

A new block is configured to enable Pulse Testing. Pulse Testing should remain enabled if the block has loads that hold one state for long periods of time, *unless any load(s) are sensitive to pulses or interruptions of up to 8mS or 1mS (DC)*. It should be disabled if the block's loads will normally change state as the program executes. These outputs will report faults during normal operation, and do not need to be pulsed.

Hand-held Monitor Configuration Steps

```
PULSE TEST
REF
ENABLED
  tgl entr nxt
```

1. Line 3 of the Pulse Test screen shows whether the capability is currently enabled. If you want to make a change, press F2 (tgl). Press F3 (enter).
2. Press F4 (next) to advance to the next configuration display.

Pulse Testing Outputs

Outputs can be pulse-tested from a Hand-held Monitor or by sending a Pulse Test command from the application program.

Pulse Testing tests the continuity of each output circuit including the switch device, power source, wiring, interposing devices (fuses, circuit breakers, terminals), and output device. For Isolated I/O blocks, Pulse Testing also allows the CPU to easily check for Loss Of I/O Power conditions.

It works whether or not there is minimum current to check for a No-Load condition. Pulse testing does not activate mechanical devices such as motor starters, relays, or solenoid valves.

Pulse Testing should momentarily cause outputs that are OFF to turn ON and outputs that are ON to go OFF. Pulse testing may cause the following diagnostics:

- Failed Switch:** If the output does not change state when pulsed.
- Short Circuit:** If the load on an output that was OFF exceeds 30 amps when pulsed ON.
- No Load:** If the load on an output that was OFF draws less than 50mA when pulsed ON.
- Loss of I/O Power:** Indicates that a pair of circuits is disconnected from field power. This diagnostic is only reported to the CPU following a Pulse Test, although it is available to the Hand-held Monitor at all times.

Input Filter Time

The block continuously samples an input for the length of the configured filter time period. If the input remains either on or off for the length of the Filter Time, the block recognizes its state. For example:

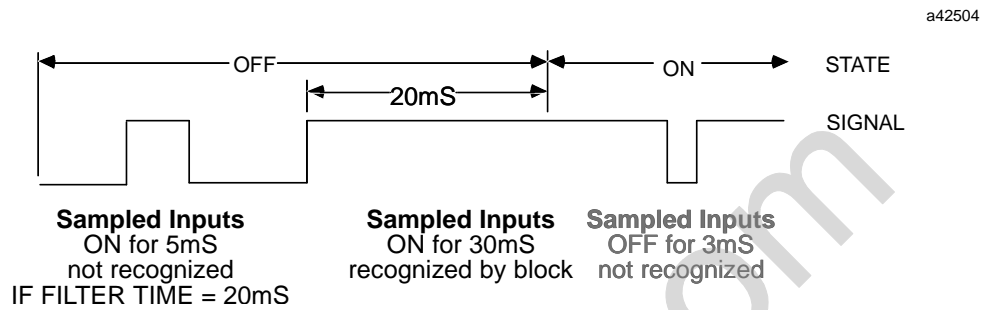

The input filter helps reject spurious noise spikes and multiple inputs generated by the bounce of mechanical devices. An input filter time of 10mS to 100mS can be selected for the block. The default filter time is 10mS (no filter).

In controlled, noise-free environments, signals generated by clean, solid state electronics may be unnecessarily slowed by a filter, delaying system response. In such an environment, no additional filter time is needed.

In noisy environments, use a longer filter time to prevent noise from possibly causing erratic or unsafe system operations.

For a block with tristate inputs, the minimum recommended Input Filter Time is 50mS.

Hand-held Monitor Configuration Steps

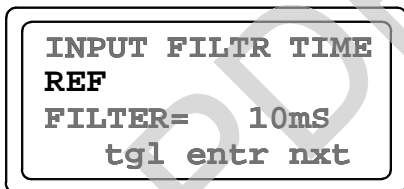

1. The screen displays the currently-selected filter time. If this time should be changed, press F2 (tgl) to display other times.
2. To save the new selection, press F3 (entr).
3. Press F4 (next) to advance to the next configuration display.

Isolated Voltage Selection

Select whether the block's I/O circuits will use 115 VAC or 125 VDC. All I/O circuits on the block must use the same type of power (it does not have to be the same as block power).

Hand-held Monitor Configuration Steps

```
ISOL VOLTAGE SEL
REF
115 VOLTS AC
  tgl entr nxt
```

1. Line 3 shows the currently-selected voltage.
2. To change the current selection, press F2 (tgl). Press F3 (entr).
3. Press F4 (next) to advance to the next configuration display.

I/O Circuit Type

An earlier configuration step selected the Block I/O type (on the Program Block ID screen). That step determined whether the block would be assigned all input references, all output references, or both. On the screen shown below, the I/O type of each circuit can be specified.

If the Block I/O Type is Combination, each circuit can be configured as an input (I), an output (O), or a tristate input (I_T). Select Tristate Input for any input circuit that should report the Open Wire diagnostic.

If the Block I/O Type is Input, each circuit can be either a regular input (I) or a tristate input (I_T). Select Tristate Input for any input circuit that should report the Open Wire diagnostic.

If the Block I/O Type is Output, each circuit must be an output (O).

Hand-held Monitor Configuration Steps

```
I/O CIRCUIT CFG
REF
ITITITITI I I I
> tgl entr nxt
```

1. Line 3 shows the I/O type of each circuit. To select a circuit, press F1 (>).
2. To change a circuit's I/O type, press F2 (tgl). To save the selection, press F3 (entr).
3. Press F4 (next) to advance to the next configuration display.

Report Faults to CPU

Fault reports to the host can be disabled or enabled for any circuit.

If fault reporting is enabled for a circuit, the block sends a message to the host if any fault occurs on that circuit.

If Fault reporting is disabled, the block does not send fault reports to the CPU for that circuit.

Regardless of whether fault *reporting* is enabled, the block detects faults on the circuit and takes appropriate action. The Unit OK LED blinks when a fault occurs, and a fault report is sent to a Hand-held Monitor. The fault condition must be corrected for proper operation of the block.

If the CPU requests diagnostic information from the block using a Read Diagnostics datagram, the block returns current diagnostics for all circuits, including any with CPU fault reporting disabled.

Hand-held Monitor Configuration Steps

```
REPORT FAULTS ?  
REF  
Y Y Y Y Y Y Y Y  
  tgl entr nxt
```

1. The screen displays the current Fault Reports configuration of all circuits on the block.
2. To select a circuit for configuration, press F1 (>).
3. To change the Report Faults configuration of a circuit, press F2 (tgl). To save the new selection, press F3 (entr).
4. Press F4 (next) to advance to the next configuration display.

Hold Last State

Each output can be configured to either hold its last state or go to its powerup default state if the block loses CPU communications for at least 3 bus scans.

For a new block, Hold Last State is disabled for each output. With Hold Last State disabled, the block sets the output to its powerup default if CPU communications are lost.

If Hold Last State is enabled, the block continues to hold the output in its current state instead of setting it to the powerup default.

Outputs remain in their last state or default indefinitely or until one of the following occurs:

- Communications with the CPU are restored.
- The Hand-held Monitor changes the output by forcing it.
- Power is removed from the block.

Hand-held Monitor Configuration Steps

```
HOLD LAST STATE?
REF
Y Y Y N N X X X
> tgl entr nxt
```

1. Line 3 shows the current Hold Last State configuration of each circuit:
 Y = hold last state.
 N = go to default state (configured on the next HHM screen)
 X = the circuit has been configured as an input.
2. To select a circuit, press F1 (>). To change the selection for a circuit, press F2 (tgl).
3. To save the new selection, press F3 (entr).
4. Press F4 (next) when you are ready to advance to the next configuration display.

Output Default State

An output goes to its powerup default state when the block is first powered up.

If Hold Last State is NOT enabled for an output, the block will also default the output if CPU communications are lost. On a non-redundant system, this occurs approximately 250mS after the third bus scan passes with no CPU communications. If the block is on a redundant bus downstream of a Bus Switching Module, more time is needed. (Additional default time for redundancy is explained on page 5-22).

Hand-held Monitor Configuration Steps

```

OUTPUT DEFAULT
REF
0 0 1 1 1 X X X
> tgl entr nxt

```

1. Line 3 shows the Output Default State configuration of all circuits:
 0 = the output default state is off.
 1 = the output default state is on.
 X = the circuit has been configured as an input.
2. To select a circuit, press F1 (>). To change the selection for a circuit, press F2 (tgl).
3. To save the new selection, press F3 (entr). Press F4 (next) to advance to the next configuration display.

Report No Load

By default, each output is configured to report No-Load diagnostics. Energizing the output activates a no-load current level. If the load does not continuously draw 50mA from the output circuit, the block sends a NO LOAD message.

Disable this diagnostic for any output where a very small loads (small relay, transformer, or indicating lamp) will draw less than 50 mA.

Hand-held Monitor Configuration Steps

```

REPORT NO LOAD?
REF
Y Y Y N N X X X
> tgl entr nxt

```

1. Line 3 shows the Report No Load configuration of all circuits:
 Y = the output will report No Load conditions.
 N = the output will not report No Load conditions.
 X = the circuit has been configured as an input.
2. To select a circuit, press F1 (>). To change the selection for a circuit, press F2 (tgl).
3. To save the new selection, press F3 (entr).
4. Press F4 (next) when you are ready to advance to the next configuration display.

Overload Shutdown

Overload Shutdown protects output loads, field wiring, and switching devices. If a load exceeds 2.8amps (2.0 amps RMS) continuously for 100mS and Overload Shutdown is enabled, the block will turn the output off and send an OVERLOAD message.

Under certain conditions (see page 5-8), Overload Shutdown detection and reporting can be disabled for output loads that require more than 2 amps RMS.

Hand-held Monitor Configuration Steps

```
OVRLOAD SHUTDWN?
REF
Y Y Y Y N X X X
> tgl entr nxt
```

1. Line 3 shows the Overload Shutdown configuration of all circuits:

Y = output will shut down and report diagnostic if overload occurs.

N = output will NOT shut down or report Overload diagnostic.

X = the circuit has been configured as an input.

1. To select a circuit, press F1 (>). To change the selection for a circuit, press F2 (tgl).
2. To save the new selection, press F3 (entr).
3. Press F4 (next) when you are ready to advance to the next configuration display.

BSM Present

If the block is connected to a single bus or to just one trunk of a dual bus, BSM Present should be set to NO.

Select YES if the block is located in a cluster connected to dual busses via a Bus Switching Module.

Hand-held Monitor Configuration Steps

```
BSM PRESENT ?  
REF  
STATUS = YES  
  tgl entr nxt
```

1. To change the BSM Present configuration, press F2 (tgl).
2. To save the new selection, press F3 (entr).
3. Press F4 (next) to advance to the next configuration display.

BSM Controller

A BSM Controller is a block to which a Bus Switching Module is directly attached, which controls the BSM's switching action. Selecting a block to be a BSM Controller block has no effect on the block's I/O type – the block can still be configured as an inputs-only block, but circuit #1 cannot be physically used as an input. The first circuit will not be under CPU control.

To change this configuration with a Hand-held Monitor, the block must first be configured for BSM PRESENT. The BSM CONTROLLER menu will not appear if BSM PRESENT is set to NO.

Hand-held Monitor Configuration Steps

```
BSM CONTROLLER?  
REF  
STATUS = NO  
  tgl entr nxt
```

1. To change the configuration, press F2 (tgl).
2. To save the new selection, press F3 (entr).
3. Press F4 (next) to advance to the next configuration display.

Output Default Time

When a Bus Switching Module is used, the Output Default Time must be long enough to allow the BSM to switch without causing outputs to default. Therefore, when BSM Present is selected (above), the block automatically changes its Output Default Time from 3 bus scans to 2.5 seconds.

If Hold Last State was selected, outputs will remain in their last state while the BSM switches, instead of defaulting, so there is no need to change this selection.

If Hold Last State was set to NO for any output on a block, and total bus scan time will exceed 100mS, change this selection to 10 seconds.

Hand-held Monitor Configuration Steps

```
OUTPUT DEF.TIME
REF
TIME = 2.5 SECS
  tgl entr nxt
```

1. To change the configuration, press F2 (tgl).
2. To save the new selection, press F3 (entr).
3. Press F4 (next) to advance to the next configuration display.

CPU Redundancy

The block can be configured for No Controller Redundancy, Hot Standby or Duplex redundancy. For new blocks, it is set for No Controller Redundancy. It must be changed only if the block should be able to receive output data from two CPUs.

In Hot Standby mode, a block receives output data from both CPUs but uses the data from only one of them to drive its outputs. The block prefers outputs sent by the bus controller with Device Number 31. If those outputs are not available, the block uses outputs from the bus controller with Device Number 30. If no outputs from a CPU are available, outputs either Hold Last State or default (as configured).

In Duplex redundancy mode, a block compares outputs received from two CPUs and sets any outputs for which there is disagreement to their Duplex Default state.

Hand-held Monitor Configuration Steps

```
CPU REDUNDANCY
REF
NO CTRL REDUND
  tgl entr nxt
```

1. To change the current selection, press F2 (tgl).
2. Press F3 (entr) to save the new selection.
3. Press F4 (next) to advance to the next configuration display.

Duplex Default State

In Duplex Redundancy mode, if the block receives different output states for given points, the block breaks the tie by outputting the Duplex Default State to those points. For new blocks, OFF is selected for all outputs. Change it if outputs should be ON.

Hand-held Monitor Configuration Steps

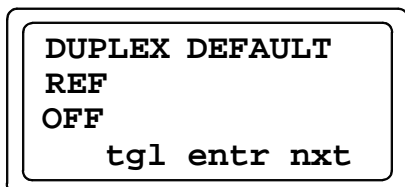

1. To change the Duplex Default state, press F2 (tgl).
2. Press F3 (entr) to save the new selection.
3. Press F4 (next) to advance to the next configuration display.

Note

If the block loses communications with BOTH CPUs, individual outputs go to their configured Hold Last State or Output Default State.

Configuration Protection

After the block is configured, its Configuration Protection should be enabled to prevent unwanted changes (from a Hand-held Monitor and from the CPU). Configuration Protection can only be set and removed by a Hand-held Monitor. For a new block, Configuration Protection is disabled.

Hand-held Monitor Configuration Steps

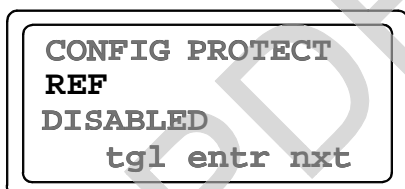

1. To change the current selection, press F2 (tgl).
2. Press F3 (entr) to save the new selection.
3. Press F4 (next) to return to the first configuration display.