

6248BP10831

New In Stock!

ABB

<http://www.pdfsupply.com/automation/abb/623-624-series/6248BP10831>

623-624-series

1-919-535-3180

Terminal Assembly for 6248BP10811

www.pdfsupply.com

Email: sales@pdfsupply.com

Chapter 7

Relay Output Blocks

6248BP10831 ABB TRIO I/O

Relay Output blocks provide 16 output circuits in four independent groups of four relay-type outputs each. The block power may be either 115V or 230V AC.

There are two types of Relay Output blocks:

- **Relay Output Block (IC660BBR100)**, Relays Normally-closed.
- **Relay Output Block (IC660BBR101)**, Relays Normally-open.

Features

Each group of four outputs on a Relay Block can be powered by a separate AC or DC source. Group to group isolation is 1500 volts.

Relay blocks are compatible with a wide range of low-power control and indicating devices such as relays, contactors, and lamps. Output devices may operate in the range of 5V to 250VAC or 5V to 220VDC, and switch up to 60 Watts or 125 VA.

Configurable features of these blocks include:

- Output powerup defaults
- Output Hold Last State or default
- CPU Redundancy type
- Bus Switching Module control

Block LEDs indicate proper block operation and CPU communications. Individual LEDs show the commanded output state of each coil.

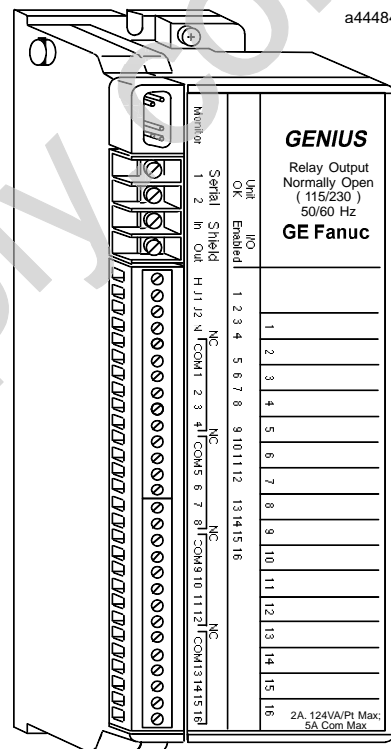

Compatibility

These blocks can be used with any type of GE Fanuc Genius bus interface module. They can also be used with any PCIM or QBIM module.

They are compatible with a Hand-held Monitor identified by catalog number IC660HHM501 only.

Specifications

Block Type: Catalog Numbers: Output Block, Normally-Closed Relays Terminal Assembly only Electronics Assembly only Output Block, Normally-Open Relays Terminal Assembly only Electronics Assembly only	16 circuit relay outputs in four isolated groups of four IC660BBR100 IC660TBR100 IC660EBR100 IC660BBR101 IC660TBR101 IC660EBR101																																																
Size (height x width x depth): Weight LEDs (I/O Block) LEDs (each circuit)	8.83" (22.44cm) x 3.50" (8.89cm) x 3.94" (10.00cm) 4 lbs. (1.8 kg) Unit OK, I/O Enabled Individual relay coil state																																																
Environmental Specifications: Operating temperature Storage temperature Humidity Vibration	0C to +60C (32F to +140F) -40C to +100C (-40F to +212F) 5 to 95% (non-condensing) 5-10Hz 0.2" (5.08mm) displacement; 10-200Hz at 1G																																																
Block Power Supply: Frequency Operating voltage Power requirement Power supply dropout time Isolation All outputs to chassis ground Between output groups Power terminals to chassis ground Power terminals to outputs Comms terminals to power terminals Comms terminals to outputs Heat Dissipation	47-63 Hz (115VAC) 93VAC to 132VAC; (230VAC) 185VAC to 265VAC 87mA at 115 VAC 1 cycle 1500 VAC 1500 VAC 1700 VDC 1500 VAC 1700 VDC 1500 VAC 10.1 watts maximum with 16 outputs on																																																
Output Characteristics: Maximum Output current Maximum switching power Maximum inrush current Output OFF leakage current Maximum switching frequency Output turn-on delay (maximum) Output voltage range Minimum recommended load	2 amps per circuit 60 Watts or 125 VA 2 amps per circuit 0.1 mA 20 cycles/minute (inductive loads) 5mS 5V to 250V AC or 5V to 220V DC 10 mA																																																
Relay Type Initial Contact Resistance	Fixed coil moving armature 100 milliohms, maximum																																																
Typical Life: Operating Voltage:	<table border="1"> <thead> <tr> <th rowspan="2"></th> <th colspan="3">Maximum Current for Load Type*</th> <th rowspan="2">Typical Life (operations)</th> </tr> <tr> <th>Resistive</th> <th>Lamp</th> <th>Solenoid</th> </tr> </thead> <tbody> <tr> <td>250VAC</td> <td>0.5A</td> <td>--</td> <td>--</td> <td>200,000</td> </tr> <tr> <td>250VAC</td> <td>--</td> <td>0.1A</td> <td>0.1A</td> <td>100,000</td> </tr> <tr> <td>125VAC</td> <td>1.0A</td> <td>0.2A</td> <td>0.3A</td> <td>100,000</td> </tr> <tr> <td>220VDC</td> <td>0.3A</td> <td>--</td> <td>--</td> <td>100,000</td> </tr> <tr> <td>110VDC</td> <td>0.6A</td> <td>--</td> <td>--</td> <td>100,000</td> </tr> <tr> <td>30VDC</td> <td>2.0A</td> <td>--</td> <td>--</td> <td>500,000</td> </tr> <tr> <td>30VDC</td> <td>--</td> <td>0.2A</td> <td>0.3A</td> <td>100,000</td> </tr> <tr> <td>12VDC</td> <td>--</td> <td>0.3A</td> <td>0.5A</td> <td>100,000</td> </tr> </tbody> </table>		Maximum Current for Load Type*			Typical Life (operations)	Resistive	Lamp	Solenoid	250VAC	0.5A	--	--	200,000	250VAC	--	0.1A	0.1A	100,000	125VAC	1.0A	0.2A	0.3A	100,000	220VDC	0.3A	--	--	100,000	110VDC	0.6A	--	--	100,000	30VDC	2.0A	--	--	500,000	30VDC	--	0.2A	0.3A	100,000	12VDC	--	0.3A	0.5A	100,000
	Maximum Current for Load Type*			Typical Life (operations)																																													
	Resistive	Lamp	Solenoid																																														
250VAC	0.5A	--	--	200,000																																													
250VAC	--	0.1A	0.1A	100,000																																													
125VAC	1.0A	0.2A	0.3A	100,000																																													
220VDC	0.3A	--	--	100,000																																													
110VDC	0.6A	--	--	100,000																																													
30VDC	2.0A	--	--	500,000																																													
30VDC	--	0.2A	0.3A	100,000																																													
12VDC	--	0.3A	0.5A	100,000																																													
Effect of Additional Current on Operating Life:	<table border="1"> <thead> <tr> <th rowspan="2"></th> <th colspan="3">Current in Load Type</th> <th rowspan="2">Typical Life (operations)</th> </tr> <tr> <th>Resistive</th> <th>Lamp</th> <th>Solenoid</th> </tr> </thead> <tbody> <tr> <td>250VAC</td> <td>0.1A</td> <td>--</td> <td>--</td> <td>1,500,000</td> </tr> <tr> <td>125VAC</td> <td>0.3A</td> <td>--</td> <td>--</td> <td>1,000,000</td> </tr> <tr> <td>30VDC</td> <td>1.0A</td> <td>--</td> <td>--</td> <td>2,000,000</td> </tr> <tr> <td>12VDC</td> <td>2.0A</td> <td>--</td> <td>--</td> <td>1,000,000</td> </tr> </tbody> </table> <p>* Lamp loads are defined as a X10 inrush with a power factor (PF) of 1.00; when turned OFF, they represent a PF of 1.00. Solenoids are defined as a X10 inrush with a PF of 0.65; when turned OFF, they represent a PF of 0.35.</p>		Current in Load Type			Typical Life (operations)	Resistive	Lamp	Solenoid	250VAC	0.1A	--	--	1,500,000	125VAC	0.3A	--	--	1,000,000	30VDC	1.0A	--	--	2,000,000	12VDC	2.0A	--	--	1,000,000																				
	Current in Load Type			Typical Life (operations)																																													
	Resistive	Lamp	Solenoid																																														
250VAC	0.1A	--	--	1,500,000																																													
125VAC	0.3A	--	--	1,000,000																																													
30VDC	1.0A	--	--	2,000,000																																													
12VDC	2.0A	--	--	1,000,000																																													

Block Operation

All of a Relay Output block's 16 relay-type outputs are either normally-open or normally-closed (depending on the block version). Outputs are grouped into four groups of four relays. Each group of four shares a common input terminal.

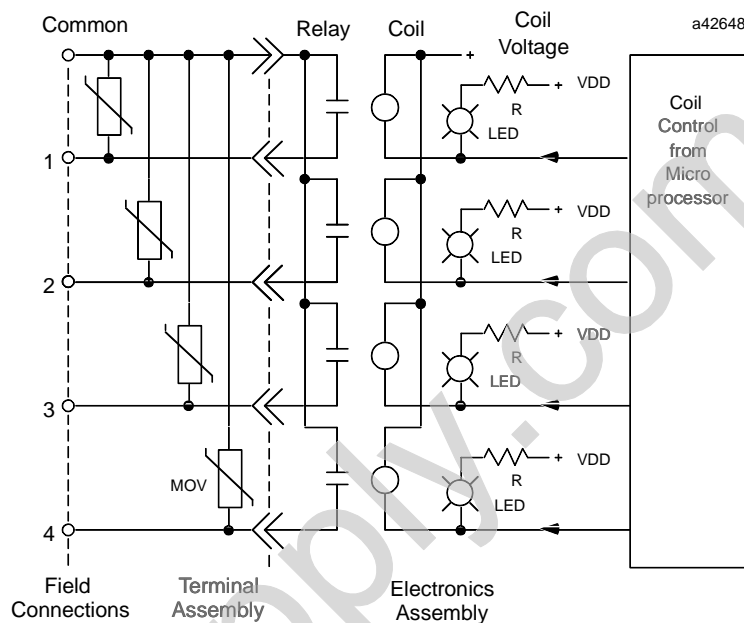

NOTE: Relay Normally-Open version shown. Normally-closed is the same, except for relay type.

Circuit LEDs

Each circuit has its own LED indicator that shows the commanded state of the coil.

Output Data Format

A Relay Output Block receives 2 bytes of output data from the CPU each bus scan. Appendix B shows reference usage for a Series 90, Series Six, or Series Five PLC.

Byte #	Description
0	Outputs 1 – 8 (output 1 in bit 0)
1	Outputs 9 – 16 (output 9 in bit 0)

The block echos the 2 data bytes each bus scan. PLCs ignore the echoed data. However, it can be displayed on a Hand-held Monitor.

Relay States

A logical '1' received from the CPU causes a Relay block to energize the corresponding relay coil; a '0' causes the coil to be deenergized. When the coil of a Normally-open relay is energized, the relay contact closes. When the coil of a Normally-closed relay is energized, the relay contact opens.

Coil Type	Coil State	Action of Relays
Normally-open relay	ON (1)	relay closes
	OFF (0)	relay opens
Normally-closed relay	ON (1)	relay opens
	OFF (0)	relay closes

Hand-held Monitor Output Display

The Hand-held Monitor displays the current states of all outputs on line 4 of the Monitor Block screen.

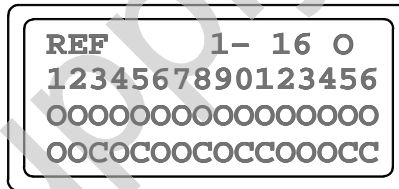

Individual circuits are displayed on the Monitor/Control Reference screen (which also shows an output's fault and force status).

Diagnostics

The Relay Output blocks support the EEPROM Failure diagnostic only. There are no diagnostics associated with the individual circuits.

Field Wiring

Field devices are wired to terminals 5–32, which accept AWG #22 through AWG #12 wires. Do not overtorque the terminal screws.

Block Power

Relay Output blocks require a 115 VAC or 230 VAC power source. Voltage selection is made by jumpers on the Terminal Assembly. When shipped from the factory, the power selection jumpers are set for 115 VAC operation. For 230 volt AC power, change the jumpers as shown below. Care must be taken to ensure correct jumper placement. Incorrect jumper placement may result in damage to the block.

Block Power Options

a42511

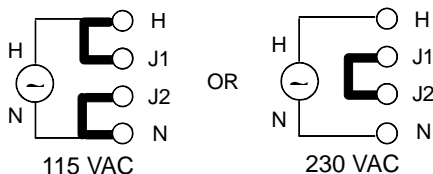

Connect an appropriate power source to the H and N terminals (5 and 8).

Note

If Class 1 Division 2 conditions must be met for Factory Mutual, install an external 250 volt 1/8 amp slow-blow fuse in series with the Hot AC power connector as shown below.

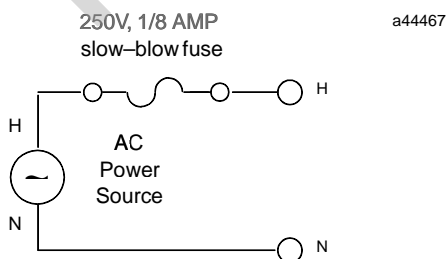

With the external fuse indicated, this block meets FM Class 1 Division 2 requirements.

Wiring for Output Devices

Power for AC loads may come from the block AC power supply or other AC source(s). Power for DC loads may come from one or more DC sources. Each group may use a separate AC or DC source.

External Fuses and Snubbers

Relay blocks have no internal fuses. Following normal practices, external fuses of 2 amps or less can be installed in series to protect loads.

External snubbers are not necessary for correct operation of the block. However, the use of snubbers is recommended. Snubbers will protect loads from switching transient pulses and lengthen the contact life of the relays. Use a diode connected in parallel with a DC inductive load or an R-C network across the contacts.

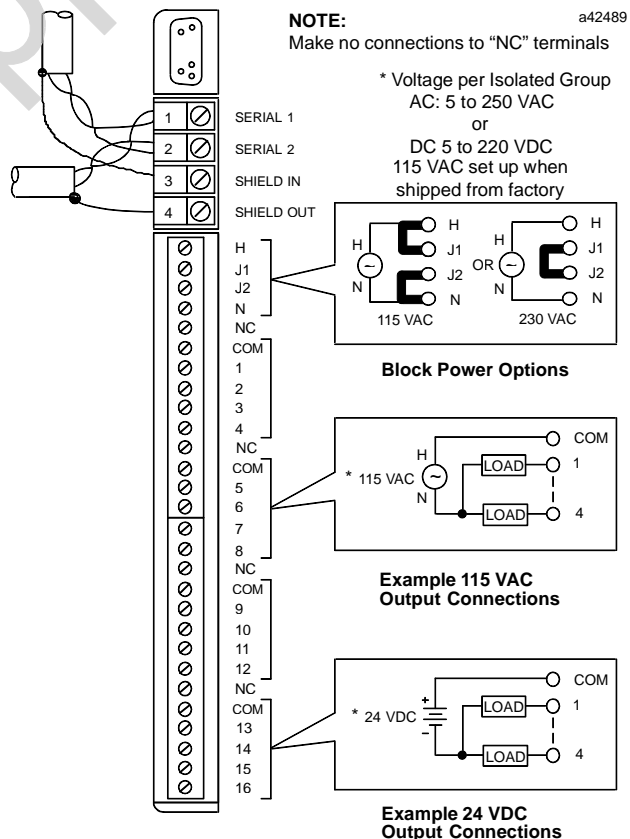

Using a Relay Block as a BSM Controller

Both types of Relay Block (IC660BBR100 and BBR101) can be used to control a Bus Switching Module. There are two different BSM versions available. It is important to match the BSM to the type of voltage that will power the block's outputs. If this voltage will be 24/48 VDC, BSM version IC660BSM021 is required. If the voltage will be 115 VAC or 125 VDC, IC660BSM120 is needed instead. Connect the BSM to the block as shown below.

Block and Points Powered by 115 VAC

If the block and points are powered by 115 VAC, connect one wire of BSM version IC660BSM120 to point 1 and connect the other BSM wire to N. Jumping terminal J1 to COM as shown below allows the points to operate on the same 115 VAC source that powers the block.

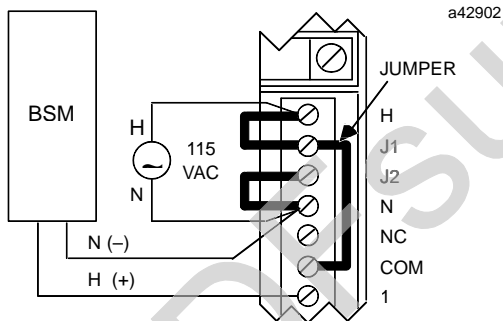

Block Powered by 230 VAC, Points Powered by 24-48 VDC

If the block is powered by 230 VAC and the points are powered by a 24-48 VDC source, connect one wire of BSM version IC660BSM021 to point 1 and the other to DC- (24-48VDC).

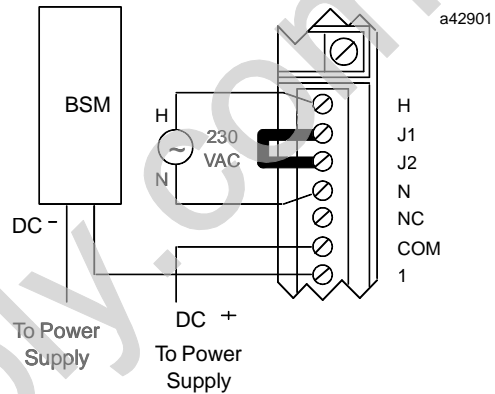

Block Powered by 230 VAC, Points Powered by 115 VAC or 125 VDC

If the block is powered by 230 VAC and the points are powered by either a 115 VAC source or a 125 VDC source, use BSM version BSM120. Connect one wire of the BSM to point 1. For a 125 VDC source, connect the other BSM wire to DC-. For a 115 VAC source, connect the other BSM wire to the neutral side of the power supply.

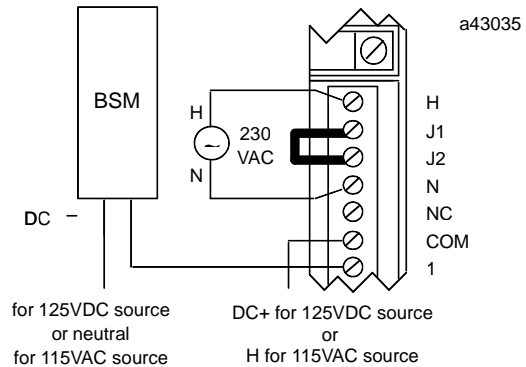

Block Configuration

The configurable features of a Relay Output Block are listed below. For many, the factory setting will not need to be changed.

Feature	Circuit or Block	Factory Setting	Selections
Device Number*	Block	null	0 to 31 (a number must be selected)
Reference Address*	Block	none	Depends on host CPU type
Baud Rate*	Block	153.6std	153.6 std, 153.6 ext, 76.8, 38.4 Kbd
Hold Last State	Circuit	no	yes, no
Output Default State	Circuit	coil off	coil on, off
BSM Present	Block	no	yes, no
BSM Controller	Block	no	yes, no
Output Default Time	Block	3 bus scans	(for bus redundancy) 2.5 or 10 sec
CPU Redundancy	Block	none	none, hot standby, duplex
Duplex Default	Block	off	on, off
Configuration Protection	Block	disabled	enabled, disabled

Features marked with an asterisk in the table are configured from the Program Block ID screen of the Hand-held Monitor, as explained in chapter 3.

The rest of the features can be configured either using a Hand-held Monitor, or by sending a Write Configuration datagram to the block from the host.

Before configuration begins, the block's features should be decided on and recorded on a copy of the Configuration Worksheet printed on the next page.

16 Circuit Relay Output Blocks Configuration Worksheet

Block _____ Location _____

Block Features:

Configuration Protected (Y/N) _____ Block Number (0-31) _____

Reference Address _____ through _____

Baud Rate (153.6 Kb Std/153.6 Kb Ext/76.8 Kb/38.4 Kb) _____

Redundancy Features:

Redundancy Mode (None/Standby/Duplex) _____ Duplex Default (on/off) _____

BSM Present (Y/N) BSM Controller (Y/N) _____ Outputs Default (2.5/10 sec) _____

Circuit Features:

	Reference Address	Hold Last State (yes/no)	Default State (ON/OFF)
1	_____	_____	_____
2	_____	_____	_____
3	_____	_____	_____
4	_____	_____	_____
5	_____	_____	_____
6	_____	_____	_____
7	_____	_____	_____
8	_____	_____	_____
8	_____	_____	_____
10	_____	_____	_____
11	_____	_____	_____
12	_____	_____	_____
13	_____	_____	_____
14	_____	_____	_____
15	_____	_____	_____
16	_____	_____	_____

Hold Last State

Each output can be independently configured to either hold its last state or default if the block loses CPU communications for at least 3 bus scans.

For a new block, Hold Last State is disabled for each output. With Hold Last State disabled, the block sets the output to its powerup default if CPU communications are lost.

If Hold Last State is enabled, the block continues to hold the output in its current state instead of setting it to the powerup default.

Outputs remain in their last state or default indefinitely or until one of the following occurs:

- Communications with the CPU are restored.
- The Hand-held Monitor changes the output by forcing it.
- Power is removed from the block.

Hand-held Monitor Configuration Steps

```

HOLD LAST STATE?
REF
YYNYNYNYNYNYNYN
> tgl entr nxt

```

1. The screen displays the current Hold Last State configuration of all circuits. On this screen,
 - Y = hold last state.
 - N = go to default state (configured on the next HHM screen)
2. To select a circuit, press F1 (>).
3. To change the selection for a circuit, press F2 (tgl). To save the new selection, press F3 (entr). Press F4 (next) to advance to the next configuration display.

Output Default State

An output goes to its powerup default state when the block is first powered up.

If Hold Last State was NOT enabled, the block will also default the output if CPU communications are lost. On a non-redundant system, this occurs approximately 250mS after the third bus scan passes with no CPU communications. If the block is on a redundant bus downstream of a Bus Switching Module, more time is needed. (Additional default time for redundancy is explained on page 7-11.)

Hand-held Monitor Configuration Steps

```

OUTPUT DEFAULT
REF
CCOCCOCOCOCOCOC
> tgl entr nxt

```

1. The screen displays the Output Default state configuration of all relays. On this screen,
 - C = Output Default is closed.
 - O = Output Default is open.
2. To select a circuit, press F1 (>).
3. To change the selection for a circuit, press F2 (tgl). To save the new selection, press F3 (entr). Press F4 (next) when you are ready to advance to the next configuration display.

BSM Present

If the block is connected to a single bus or to just one trunk of a dual bus, BSM Present should be set to NO (the default).

Change it to YES if the block is located in a cluster connected to dual busses via a Bus Switching Module.

Hand-held Monitor Configuration Steps

```
BSM PRESENT ?  
REF  
STATUS = NO  
  tgl entr nxt
```

1. To change the BSM Present configuration, press F2 (tgl).
2. To save the new selection, press F3 (entr).
3. Press F4 (next) to advance to the next configuration display.

BSM Controller

A BSM Controller is a block to which a Bus Switching Module is directly attached, which controls the BSM's switching action. The default setting for this feature is NO. Change it to YES if the block will be a BSM Controller.

To change this configuration with a Hand-held Monitor, the block must first be configured for BSM PRESENT. The BSM CONTROLLER menu will not appear if BSM PRESENT is set to NO.

Hand-held Monitor Configuration Steps

```
BSM CONTROLLER?  
REF  
STATUS = NO  
  tgl entr nxt
```

1. To change the configuration, press F2 (tgl).
2. To save the new selection, press F3 (entr).
3. Press F4 (next) to advance to the next configuration display.

Output Default Time

When a Bus Switching Module is used, the Output Default Time must be long enough to allow the BSM to switch without causing outputs to default. Therefore, when BSM Present is selected (above), the block automatically changes its Output Default Time from 3 bus scans to 2.5 seconds.

If Hold Last State was selected, outputs will remain in their last state while the BSM switches, instead of defaulting, so there is no need to change this selection.

If Hold Last State was set to NO for any output on a block, and total bus scan time will exceed 100mS, change this selection to 10 seconds.

Hand-held Monitor Configuration Steps

```
OUTPUT DEF.TIME  
REF  
TIME = 2.5 SECS  
  tgl entr nxt
```

1. To change the configuration, press F2 (tgl).
2. To save the new selection, press F3 (entr).
3. Press F4 (next) to advance to the next configuration display.

CPU Redundancy

The block can be configured for No Controller Redundancy, Hot Standby or Duplex redundancy. For new blocks, it is set for No Controller Redundancy. It must be changed only if the block should be able to receive output data from two CPUs.

In Hot Standby mode, a block receives output data from both CPUs but uses the data from only one of them to drive its outputs. The block prefers outputs sent by the bus interface module (Bus Controller or PCIM) with Device Number 31. If those outputs are not available, the block will use outputs from the bus interface module with Device Number 30. If no outputs from a CPU are available, outputs will either Hold Last State or go to their defaults.

In Duplex redundancy mode, a block compares outputs received from two CPUs and sets any outputs for which there is disagreement to their Duplex Default state.

Hand-held Monitor Configuration Steps

```
CPU REDUNDANCY  
REF  
NO CTRL REDUND  
  tgl entr nxt
```

1. To change the current selection, press F2 (tgl).
2. Press F3 (entr) to save the new selection.
3. Press F4 (next) to advance to the next configuration display.

Duplex Default State

In Duplex Redundancy mode, if the block receives different output states for given points, the block breaks the tie by outputting the Duplex Default State to those points. For new blocks, OFF is selected for all outputs. Change it if outputs should be ON.

Coil Type	Coil State	Action of Relays
Normally-open relay	ON (1)	relay closes
	OFF (0)	relay opens
Normally-closed relay	ON (1)	relay opens
	OFF (0)	relay closes

Hand-held Monitor Configuration Steps

```
DUPLEX DEFAULT
REF
OFF
  tgl entr nxt
```

1. To change the Duplex Default state, press F2 (tgl). Press F3 (entr) to save the new selection.
2. Press F4 (next) to advance to the next configuration display.

Note

If the block loses communications with BOTH CPUs, individual outputs go to their configured Hold Last State or Output Default State.

Configuration Protection

This feature can be used to protect the block's configuration, preventing changes from the CPU or Hand-held Monitor. It can only be selected from the Hand-held Monitor. To make subsequent changes, protection must be removed again using the Hand-held Monitor. For a new block, configuration is unprotected. Before a block is used in the system, its configuration should be protected.

Hand-held Monitor Configuration Steps

```
CONFIG PROTECT
REF
DISABLED
  tgl entr nxt
```

1. To change the current selection, press F2 (tgl).
2. Press F3 (entr) to save the new selection. Press F4 (next) to return to the first configuration display.