



# *GE Fanuc Automation*

---

*Programmable Control Products*

*Operator Interface  
Terminal*

*User's Manual*

*GFK0505*

*August 1993*

## *Warnings, Cautions, and Notes as Used in this Publication*

### **Warning**

Warning notices are used in this publication to emphasize that hazardous voltages, currents, temperatures, or other conditions that could cause personal injury exist in this equipment or may be associated with its use.

In situations where inattention could cause either personal injury or damage to equipment, a Warning notice is used.

### **Caution**

Caution notices are used where equipment might be damaged if care is not taken.

### **Note**

Notes merely call attention to information that is especially significant to understanding and operating the equipment.

This document is based on information available at the time of its publication. While efforts have been made to be accurate, the information contained herein does not purport to cover all details or variations in hardware or software, nor to provide for every possible contingency in connection with installation, operation, or maintenance. Features may be described herein which are not present in all hardware and software systems. GE Fanuc Automation assumes no obligation of notice to holders of this document with respect to changes subsequently made.

GE Fanuc Automation makes no representation or warranty, expressed, implied, or statutory with respect to, and assumes no responsibility for the accuracy, completeness, sufficiency, or usefulness of the information contained herein. No warranties of merchantability or fitness for purpose shall apply.

The following are trademarks of GE Fanuc Automation North America, Inc.

Alam Master	CIMSTAR	Helpmate	PROMACRO	Series Six
CIMPLICITY	GENet	Logicmaster	Series One	Series 90
CIMPLICITY 90-ADS	Genius	Modelmaster	Series Three	VuMaster
CIMPLICITY PowerTRAC	Genius PowerTRAC	ProLoop	Series Five	Workmaster

The Operator Interface Terminal (OIT) User's Manual explains how to install, startup, and program the OIT. Numerous examples are provided to make it easy to create screens for displaying data from the PLC or host.

## New Features of the Operator Interface Terminal (OIT)

Many enhancements and new features have been added to the OIT in Firmware Version 3.1. The startup time for the OIT is faster and the new menu screens make the OIT easier to use. The enhancements and new features are explained below.

- **Memory expansion.** Standard color and monochrome OITs are shipped with 64K bytes of RAM and are expandable to 188K. The OIT models with OptiBASIC are shipped with 188K bytes of RAM which is the maximum. Memory is no longer "bank dependent." This relieves you of managing separate banks of data since all user memory appears as a single block.
- **New OptiTOOLS™ utilities.** A completely new set of utilities for the OIT, called OptiTOOLS, has been added. OptiTOOLS utilities give you a menu-oriented system for transferring files, programs, and data between internal memory and a personal computer for remote backup and retrieval. OptiTOOLS also give directory listings of OptiSCREEN files for both viewing and permanent documentation. For OIT models with OptiBASIC these listings also include OptiBASIC programs, user variables, and current values of variables. These capabilities increase the ease-of-use and speed of development for programs.
- **OptiSCREEN™ enhancements.** A number of enhancements have been made to OptiSCREEN, including easier graphic commands, scrolling regions, and increased function key support.
- **New VIEW statements.** (OITs with OptiBASIC Only). New OptiBASIC VIEW statements embedded in an OptiSCREEN file use data provided directly by an OptiBASIC program. The VIEW statements use the direct or indirect data to automatically display the value and to graphically animate the results without any additional programming in an OptiBASIC program. This feature simplifies application development and improves screen update speed.
- **OptiBASIC™ enhancements.** (OITs with OptiBASIC only). Dozens of new features and functions have been added to OptiBASIC, making it more powerful and flexible for program development.

## Summary of the Manual

**Chapter 1. Introduction:** Provided a description of the features, general operation, and specifications of the OIT.

**Chapter 2. Getting Started:** Explains how to get the OIT started up and describes briefly menu operation and OptiSCREEN programming.

**Chapter 3. Installation:** Describes in detail power wiring, battery installation, power-up procedures, port connector definitions, and communications wiring.

™ OptiTOOLS, OptiSCREEN, and OptiBASIC are trademarks of Nematron Corporation.

**Chapter 4. Operation:** Describes in detail all the menus (Setup, Screen, BASIC, Tools, Config, Online, Local, Run), and options under each menu.

**Chapter 5. OptiSCREEN Command Reference:** Explains all the OptiSCREEN Commands. Escape sequences for each are included.

**Chapter 6. Utility Programs for the IBM PC:** Describes how to use the utility programs, provided on diskette, which aid in the development of application programs and screens.

**Appendix A. Outline and Mounting Drawings**

**Appendix B. ASCII Codes and Special Character Sets**

**Appendix C. Screen Programming Template**

**Appendix D. ANSI Escape Sequences for PLCs**

**Appendix E. VT52 Escape Sequences**

**Appendix F. Function Key Operations**

**Appendix G. STR-LINK III Communications Protocol**

## Related Publications

GFK-0068 - *OIT with OptiBASIC User's Manual*

GFK-0361 - *Mini OIT Supplement*

At GE Fanuc automation, we strive to produce quality technical documentation. After you have used this manual, please take a few moments to complete and return the Reader's Comment Card located on the next page.

# Contents

---

<b>Chapter 1</b>	<b>Introduction</b> .....	<b>1-1</b>
	Features of the OIT .....	1-2
	Feature Comparison of OIT Models .....	1-3
	General Operation of the OIT .....	1-4
	How the Dynamic Data is Produced .....	1-4
	Creating the Screen Format .....	1-5
	Transferring Data Between the Host (PLC) and the OIT .....	1-6
	Keyboards for the OIT .....	1-8
	65-position Keyboard .....	1-8
	34-position Keyboard .....	1-10
	IBM PC-compatible Keyboards .....	1-11
	User-Customized Keyboards .....	1-11
	Specifications .....	1-12
	OIT Compatibility .....	1-13
<b>Chapter 2</b>	<b>Getting Started</b> .....	<b>2-1</b>
	Installing the AC Power .....	2-1
	Installing the Battery .....	2-1
	Attaching the Keyboard .....	2-2
	Powering-up the OIT .....	2-2
	Using the Menu-driven System .....	2-4
	Using the Configuration Menu .....	2-6
	Specifying the Default Setup .....	2-7
	Using the OptiSCREEN Editor .....	2-8
	Creating a Text Screen File .....	2-9
	Creating a Graphic Screen .....	2-13
	Changing a Screen File from Absolute to Relative .....	2-14
	Calling a Screen File from Another Screen File .....	2-15
	Creating a Sample Screen Format .....	2-17
	The Sample Program .....	2-17
	Now That You've Started .....	2-20

# Contents

---

<b>Chapter 3</b>	<b>Installation</b> .....	<b>3-1</b>
	Mounting the OIT .....	3-1
	Rear Panel Connections .....	3-2
	AC Power .....	3-2
	Bell Output Wiring .....	3-3
	Reset Input Wiring .....	3-4
	Battery Replacement .....	3-4
	Communication Interface .....	3-5
	Port Connector Definitions .....	3-6
	Handshaking with RS-232C Signals .....	3-7
	Primary Port .....	3-8
	Secondary Port .....	3-8
	Handshaking with RS-422 Signals .....	3-8
	Cable and Connector Specifications .....	3-9
	Typical Cable Wiring Configurations .....	3-10
	Multidrop Operations .....	3-13
	Configuring the OIT .....	3-13
	Wiring for RS-422 Communications .....	3-13
	How Multidrop Operation Works .....	3-17
	Installing Memory and Logic Board Jumpers .....	3-18
	Memory .....	3-18
	Jumpers .....	3-20
	CRT Adjustment .....	3-21
<b>Chapter 4</b>	<b>Operation</b> .....	<b>4-1</b>
	Turning the OIT On .....	4-2
	The Main Menu - The Main Function Bar .....	4-3
	The SETUP Menu - [F1] from the Main Function Bar .....	4-4
	The Screen Menu - [F2] from the Main Function Bar .....	4-5
	The BASIC Menu - [F5] from the Main Function Bar .....	4-7
	The TOOLS Menu - [F6] from the Main Function Bar .....	4-8
	The CONFIG Menu - [F7] from the Main Function Bar .....	4-13
	Configuration Procedure .....	4-14
	Configuration Options .....	4-14
	The ONLINE Item - [F8] from the Main Function Bar .....	4-21
	The LOCAL Item - [F9] from the Main Function Bar .....	4-21
	The RUN Item - [F10] from the Main Function Bar .....	4-21
	Keyboard Operation .....	4-21
	Alphabetic Keys .....	4-21
	Nonalphabetic Keys .....	4-22
	Cursor Keys .....	4-22
	Function Keys .....	4-22
	Miscellaneous Keys .....	4-23
	Control Keys .....	4-24

# Contents

---

<b>Chapter 5</b>	<b>OptiSCREEN Command Reference .....</b>	<b>5-1</b>
	OptiSCREEN Command Types .....	5-1
	Comment and End of File .....	5-1
	Configuration .....	5-1
	Cursor .....	5-1
	Character Attribute .....	5-1
	Line Attribute .....	5-1
	Clock and Date .....	5-1
	Display .....	5-2
	File Display .....	5-2
	Erasing and Editing .....	5-2
	Graphics .....	5-2
	Programmable Keyboard and Function Key .....	5-2
	Data Transmissions and Port Control .....	5-2
	VIEW Commands .....	5-2
	Data Fill Operations .....	5-2
	Conventions for the OptiSCREEN Commands .....	5-3
	The Comment Command and the End of File Command .....	5-3
	Configuration Commands .....	5-4
	Cursor Commands .....	5-5
	Controlling the Appearance of the Cursor .....	5-5
	Controlling the Location of the Cursor .....	5-5
	Character Attribute Commands .....	5-8
	Attributes for Both Color and Monochrome OITs .....	5-9
	Comparison of Various Character Attribute Modes .....	5-12
	Attributes for Color OITs Only .....	5-13
	Attributes for Monochrome OITs Only .....	5-15
	The ATTRIBUTE Command for all OITs .....	5-16
	Line Attribute Commands .....	5-18
	Clock and Date Commands .....	5-19
	Display and File Display Commands .....	5-20
	Erasing and Editing Commands .....	5-21
	Clearing the Screen .....	5-21
	Inserting Text .....	5-26
	Scrolling .....	5-28
	Graphics Commands .....	5-29
	Generating Boxes and Boxed Regions .....	5-30
	Drawing Bar Graphs .....	5-33

# Contents

---

	Programmable Keyboard and Function Key Commands .....	5-38
	Selecting the Programmable Keyboard .....	5-38
	Programmable Keyboard Programming .....	5-38
	Data Transmissions and Port Control Commands .....	5-43
	VIEW Commands .....	5-43
	Data Fill Operations .....	5-52
	Example Data Fill Operation .....	5-52
	Command Summary .....	5-54
<b>Chapter 6</b>	<b>Utility Programs for the IBM PC .....</b>	<b>6-1</b>
	Introduction .....	6-1
	Installation .....	6-1
	Loading Utility Programs Without Resident DOS and BASICA .....	6-2
	IWS.BAT - Start-Up Program .....	6-2
	OIT - Main Utility Menu .....	6-2
	IWSEEDIT - Screen Editor .....	6-3
	IWSDOC - Documentation Program .....	6-3
	IWSLINK - STRLINK III Emulation .....	6-3
<b>Appendix A</b>	<b>Outline and Mounting Drawings .....</b>	<b>A-1</b>
<b>Appendix B</b>	<b>ASCII Codes and Special Character Sets .....</b>	<b>B-1</b>
	ASCII Codes and Characters .....	B-1
	Supplemental Standard Graphics Set .....	B-6
	Alternate Graphics Set .....	B-8
	Supplemental Alternate Graphics Set .....	B-11
	Quad Size Character Set .....	B-12
<b>Appendix C</b>	<b>Screen Programming Template .....</b>	<b>C-1</b>
<b>Appendix D</b>	<b>ANSI Escape Sequences for PLCs .....</b>	<b>D-1</b>
<b>Appendix E</b>	<b>VT52 Escape Sequences .....</b>	<b>E-1</b>
<b>Appendix F</b>	<b>Function Key Operations .....</b>	<b>F-1</b>
<b>Appendix G</b>	<b>STR-LINK III Communications Protocol .....</b>	<b>G-1</b>

# Contents

---

Figure 1-1. The OIT - Front and Side Views .....	1-2
Figure 1-2. Typical Screen Format Created Using the OptiSCREEN Editor .....	1-5
Figure 1-3. Connecting the OIT to a Series 90-70 or Series 90-30 PCM Module .....	1-6
Figure 1-4. Connecting the OIT to a Series Six ASCII/BASIC Module .....	1-7
Figure 1-5. Connecting the OIT-OptiBASIC to a Series Six CCM Module .....	1-7
Figure 2-1. Sample Screen Format .....	2-17
Figure 3-1. Rear View of the OIT .....	3-2
Figure 3-2. Bell Output Wiring .....	3-3
Figure 3-3. Battery Assembly .....	3-4
Figure 3-4. Connecting the Battery .....	3-5
Figure 3-5. Primary Port Using DB-25P Male Connector .....	3-6
Figure 3-6. Secondary Port Using DB-25S Female Connector .....	3-7
Figure 3-7. RS-232C Point-to-Point Communication with Handshaking (OIT Primary Port to Series Six ASCII/BASIC Module Port 1 or Port 2) .....	3-10
Figure 3-8. RS-232C Point-to-Point Communication, No Handshaking (OIT Primary Port to Series Six ASCII/BASIC Module Port 1 or Port 2) .....	3-10
Figure 3-9. RS-232C Point-to-Point Communication (OIT Secondary Port or STR-LINK III) .....	3-10
Figure 3-10. RS-232C Point-to-Point Communication (OIT Secondary Port Alternate Connection to Printer or STR-LINKIII) .....	3-11
Figure 3-11. RS-422 Point-to-Point Communication (OIT Primary Port to Series Six ASCII/BASIC Module) .....	3-11
Figure 3-12. RS-232 Point-to-Point Communication with Handshaking (OIT Primary Port to Series 90-70 PCM Module Port 1 or Port 2) .....	3-11
Figure 3-13. RS-422 Point-to-Point Communication with Handshaking (OIT Primary Port or Secondary Port to Series 90-70 PCM Module Port 1 or Port 2) .....	3-12
Figure 3-14. RS-232 Point-to-Point Communication with Handshaking (OIT Primary Port to Series 90-30 PCM Module Port 1) .....	3-12
Figure 3-15. RS-422 Point-to-Point Communication (OIT Primary Port or Secondary Port to Series 90-30 PCM Module Port 2) .....	3-12
Figure 3-16. RS-422 Multidrop 2-Wire (OIT Primary Port to Series Six ASCII/BASIC Module) .....	3-14
Figure 3-17. RS-422 Multidrop 4-Wire (OIT Primary Port to Series 90-70 PCM Module Port 1 or Port 2) .....	3-15
Figure 3-18. RS-422 Multidrop 4-Wire (OIT Primary Port or Secondary Port to Series 90-30 PCM Module Port 2) .....	3-16
Figure 3-19. Logic Board-Memory Chip Location .....	3-19
Figure 3-20. Monochrome CRT Adjustment Controls .....	3-21
Figure 3-21. Color CRT Adjustment Controls .....	3-22
Figure 5-1. Key Location Numbers for the 65-Position Sealed Membrane Keyboard .....	5-40
Figure 5-2. Key Location Numbers for the 34-Position Built-In Keyboard .....	5-41
Figure A-1. Outline Drawing for OIT Models IC600KD530, 532, 533, and 534 .....	A-1
Figure A-2. Cutout Drawing for OIT Models IC600KD510, 512, 513, and 514 .....	A-1

# Contents

---

Table 1-1. Feature Comparison Between OIT Models .....	1-3
Table D-1. Escape Sequence OptiSCREEN Command .....	D-2

# Chapter 1

## Introduction

---

---

The Operator Interface Terminal (OIT) is a rugged, intelligent terminal specifically built for use in harsh environments. It is typically used as an operator control and monitoring station for industrial machines that are capable of communicating over a serial interface. These industrial machines may be host computers, CNC systems, programmable logic controllers, robots, and other computer-based data acquisition, monitoring, and control systems. In this manual, however, the intelligent machine described will usually be a Programmable Logic Controller (PLC) such as the Series 90™ -70, Series 90-30, Series Five™, or Series Six™ PLC from GE Fanuc Automation.

The Operator Interface Terminal (OIT) is available in several models.

IC600KD510 Standard Monochrome OIT  
IC600KD512 Standard Color OIT  
IC600KD513 Standard Monochrome OIT with OptiBASIC™  
IC600KD514 Standard Color OIT with OptiBASIC  
IC600KD515\* Mini OIT  
IC600KD516\* Mini OIT with Touchscreen

\* The Mini OIT is not described in this manual. For more information refer to the table in this chapter comparing OIT models. Also, refer to the Mini OIT User's Manual, GFK-0361.

### Note

There are options for OITs which are supplied by the original manufacturer, but not stocked or sold by GE Fanuc Automation. For additional information, contact GE Fanuc Automation Customer Service.

This manual describes all standard sized OIT models. Throughout this manual, the term Operator Interface Terminal or OIT is used to describe the features of all the models. If a term such as OIT-Color or OIT-OptiBASIC is used, then the information applies to that specific model only.

This chapter provides an overview of the OIT. The topics covered are:

- Features of the OIT
- Feature Comparison of GE Fanuc OIT Models
- General System Operation
- Keyboards for the OIT
- Specifications
- OIT Compatibility

™ OptiBASIC is a trademark of Nematron Corporation.

## Features of the OIT

The OIT is an intelligent terminal that stores screen files generated by the OptiSCREEN™ utility. And for the OIT with OptiBASIC, BASIC programs generated by the OptiBASIC utility can also be stored and executed. The OIT is built to NEMA 4 and NEMA 12 specifications making it ideal for factory floor applications. The OIT operates using either the ANSI X3.64, the VT-100, or the VT-52 escape sequences. This means the OIT can replace many terminals which also use these escape sequences such as the DEC VT-100 and VT-220. See the illustration of the OIT below.

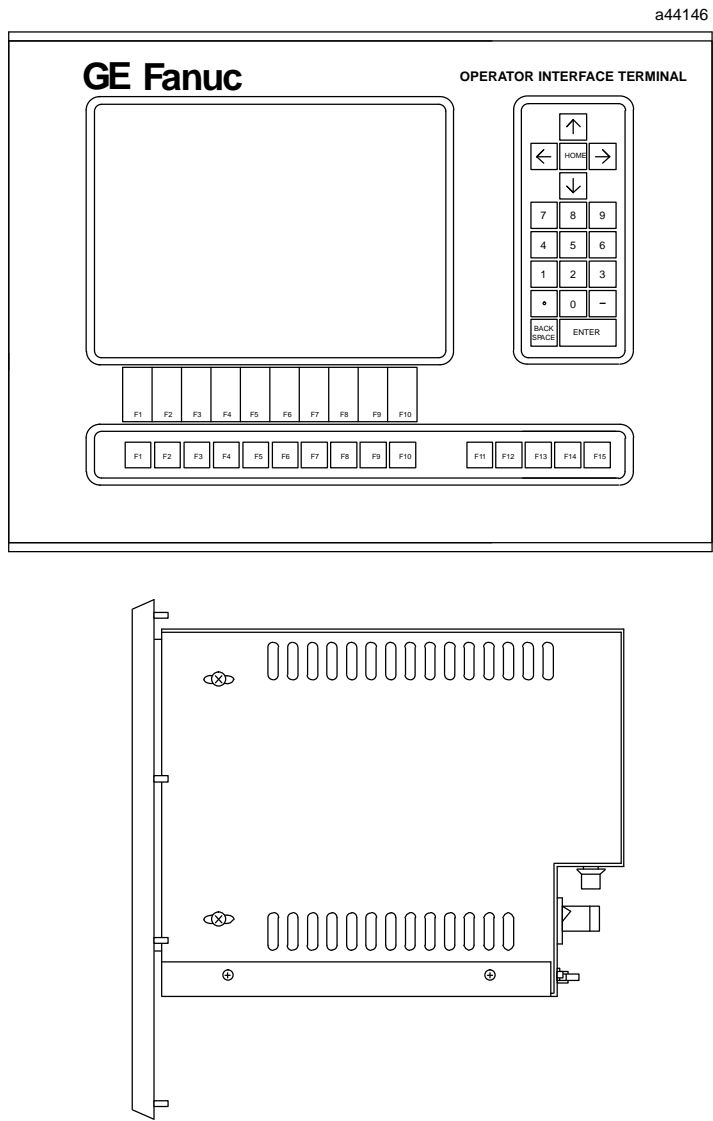

Figure 1-1. The OIT - Front and Side Views

™ OptiSCREEN is a trademark of Nematron Corporation.

Other important features of the OIT are described below.

- **OptiSCREEN Editor:** The OptiSCREEN Editor allows you to easily create and store screens which are used to display data from the PLC or host. English language commands are used instead of escape sequences.
- **OptiBASIC Editor:** The OIT-OptiBASIC Models allow you to create and store OptiBASIC programs. The OIT can also act as a stand-alone computer and execute these programs thereby eliminating the need for the PLC or host to control the OIT. OptiBASIC programs are special purpose BASIC programs that contain additional commands and statements that make it easy to interact with the terminal functions of the OIT.
- **Serial Interfaces:** The serial ports are typically used to connect to a host such as a PLC and to a printer. There are two serial ports on the OIT referred to as the Primary port and the Secondary port. Both ports have RS-232C and RS-422 capabilities and the Secondary port contains two sets of RS-232C Data In and Data Out signals effectively giving you a third port.
- **OIT Memory:** The standard OIT monochrome and color models without OptiBASIC are shipped with 64K RAM and are expandable to 188K RAM. The OIT models with OptiBASIC are shipped with 188K RAM which is the maximum.
- **Menu-Driven Software:** The menu-driven software allows you to easily access the OIT functions: OptiSCREEN and OptiBASIC editors, system configuration, and file and screen transfers.
- **Keyboards:** GE Fanuc offers a NEMA 4, ASCII sealed keyboard for use with the OIT. There are also a DIN connector and a modular phone plug connector for the standard and portable IBM PC/PC-XT and keyboard.
- **Clock and Calendar Display:** A battery-backed clock and calendar display the time and date at the bottom of the screen if desired. The clock and calendar can be reset from either the keyboard or through external commands. Moreover, the time and date can be used for time and date stamping of all OIT functions.

## Feature Comparison of OIT Models

The table below explains the differences in features between the full-sized monochrome OIT (with and without OptiBASIC), the full-sized color OIT (with and without OptiBASIC), and the Mini OIT.

Table 1-1. Feature Comparison Between OIT Models

Feature	Full Size Monochrome IC600KD510, 513	Full Size Color IC600KD512, 514	Mini OIT IC600KD515, 516
OptiSCREEN Editing	Yes	Yes	Yes
Touch Screen CRT	No	No	Yes IC600KD516 only
Keyboards Available (Sealed Membrane type)	34-pos. built in 65-position full ASCII	34-pos. built in 65-position full ASCII	65-position full ASCII
OptiBASIC Available	Yes IC600KD513 only	Yes IC600KD514 only	No
Ports	3 serial	3 serial	1 serial 1 parallel

**Table 1-1. Feature Comparison Between OIT Models - Continued**

Feature	Full Size Monochrome IC600KD510, 513	Full Size Color IC600KD512, 514	Mini OIT IC600KD515, 516
User Memory	IC600KD510- 64 Kbytes shipped 188 Kbytes total  IC600KD513- 188 Kbytes shipped and total	IC600KD512- 64 Kbytes shipped 188 Kbytes total  IC600KD514- 188 Kbytes shipped and total	IC600KD515, IC600KD516- 30 Kbytes  shipped 62 Kbytes total
Character Sets	95 ASCII, 161 Graphic, 80 Quad Size letters, numbers, symbols	95 ASCII, 161 Graphic, 80 Quad Size letters, numbers, symbols	95 ASCII, 33 Graphic from Stand. char. set. No Alter- nate character set or Quad size process symbols
IBM Keyboard Connector Types	DIN for full-size IBMPC/ PC-XT. Modular for porta- ble IBMPC/PC-XT	DIN for full-size IBMPC/ PC-XT. Modular for porta- ble IBMPC/PC-XT	DIN type only for full size IBMPC/PC-XT
Color CRT	No	Yes	No
Screen Size	12" diag. 25 lines, 80 char. per line	12" diag. 25 lines, 80 char. per line	5" x 9", 16 lines, 80 char. per line
Status Lines	1-4	1-4	None
Battery Backed Clock and Calendar	Yes	Yes	No
Bell Output	Yes	Yes	No
Reset Input	Yes	Yes	No

## General Operation of the OIT

The OIT is designed to receive dynamic (changing) data from the host computer (PLC) and display it on the screen in a user-programmed screen format. This format is created using the OptiSCREEN Editor and typically does not change as often as the dynamic information from the PLC. The operator can enter data and initiate action to be taken by the PLC by pressing keys on the keyboard.

The information displayed on the OIT is of two types.

- Dynamic data such as counter or timer values from the PLC.
- Screen format programmed using the OptiSCREEN Editor which makes the dynamic information easy to read.

## How the Dynamic Data is Produced

The origin of the dynamic data displayed on the OIT is the host or PLC. This data can be raw data, but often it needs to be processed in some way before it is displayed. This processing can be done by the host (PLC) or if you have one of the OIT-OptiBASIC models, by the OIT itself.

The Series 90-70 and Series 90-30 PCM modules can be used for processing raw data through the modules' resident BASIC. The ASCII/BASIC module provides the same capability for the Series Six PLC. These modules also retrieve operator-entered data and key presses to be acted upon by the PLC.

## Creating the Screen Format

The OptiSCREEN Editor allows you to create screen formats easily, using English-language commands instead of the cumbersome escape sequences required on some terminals. The screen format usually consists of the screen title, explanations of the dynamic data, and any graphics such as lines and boxes used to clearly present the data.

The figure below illustrates a typical screen format.

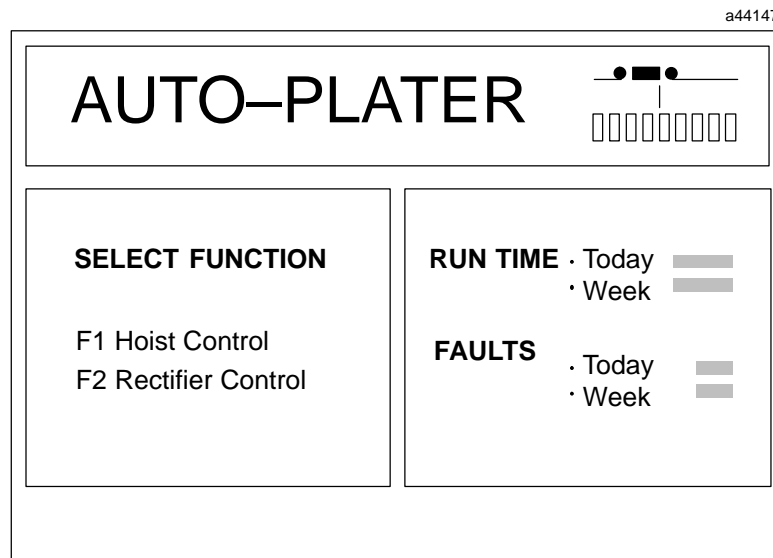

Figure 1-2. Typical Screen Format Created Using the OptiSCREEN Editor

## Transferring Data Between the Host (PLC) and the OIT

The serial ports include an RS-232 or an RS-422 interface which can be connected to an intelligent module such as the Series 90-70 or Series 90-30 PCM module or a Series Five or Series Six ASCII/BASIC or CCM module.

The figures below show the connections for a serial configuration using the OIT.

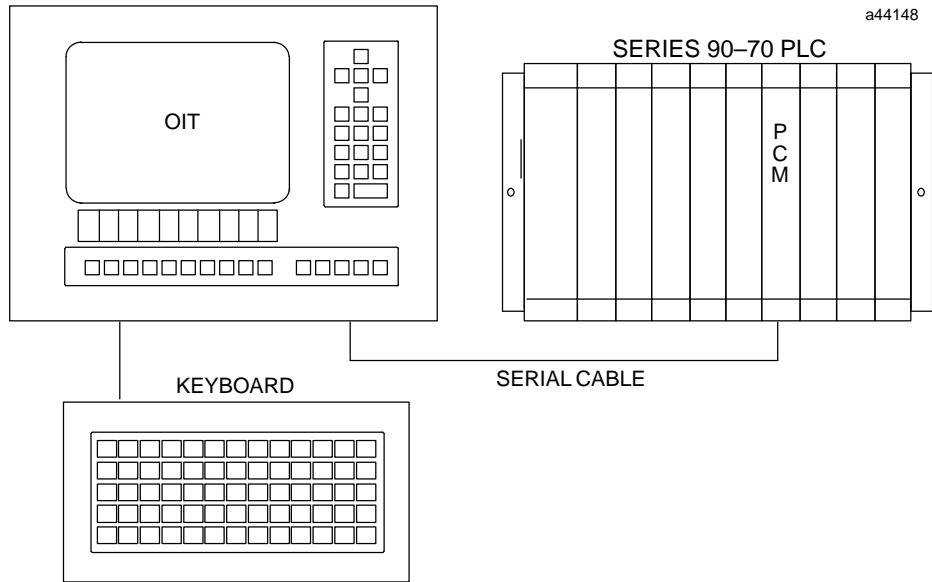

Figure 1-3. Connecting the OIT to a Series 90-70 or Series 90-30 PCM Module

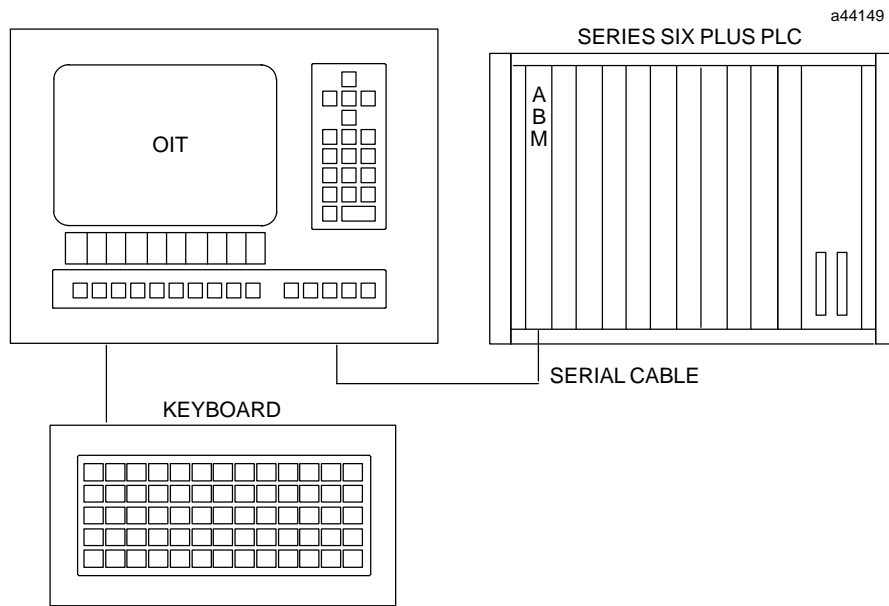

Figure 1-4. Connecting the OIT to a Series Six ASCII/BASIC Module

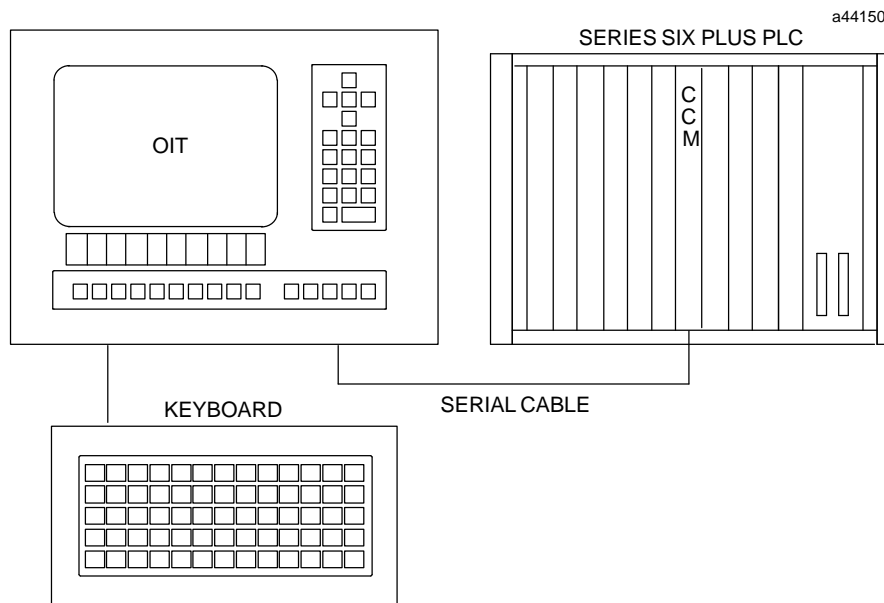

Figure 1-5. Connecting the OIT-OptiBASIC to a Series Six CCM Module

## Keyboards for the OIT

The OIT comes with an integral 34-position sealed-membrane keyboard. This built-in keyboard is sufficient to perform most operator functions. However, for system configuration and screen or program development, you will need to use either a standard IBM PC or PC-XT keyboard or a 65-position sealed-membrane keyboard available from GE Fanuc Automation.

### 65-position Keyboard

The 65-position sealed-membrane keyboard (IC600KD511) features a 5 by 13 block layout of large rectangular keys on 0.95" centers. The key legends are printed on strips of material that slide inside the keyboard matrix.

#### Terminal Inserts

a42850

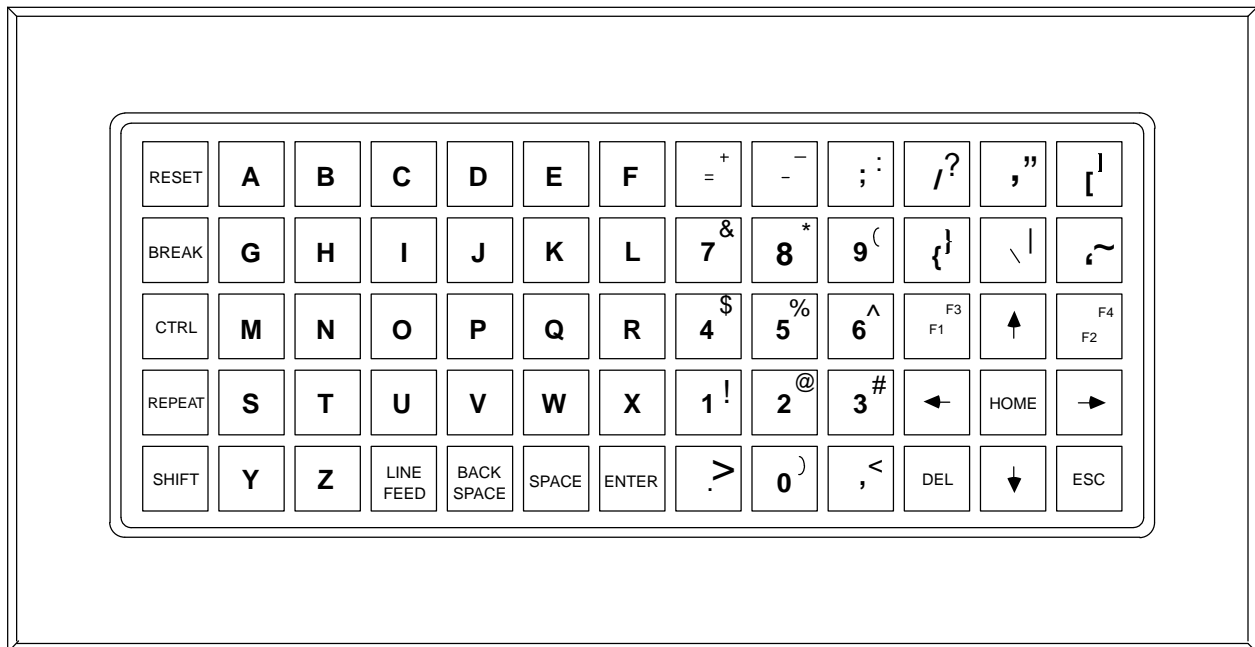

### BASIC Inserts

a42851

RESET	A	B	C	D	E	F	= +	- -	; :	/ ?	F1	F2
BREAK	G	H	I	J	K	L	7 &	8 *	9 (	{ }	F3	F4
CTRL	M	N	O	P	Q	R	4 \$	5 %	6 ^	[	F5	F6
REPEAT	S	T	U	V	W	X	1 !	2 @	3 #	\	F7	F8
SHIFT	Y	Z	, "	BACK SPACE	SPACE	ENTER	. >	0 )	, <	~	F9	F10

### QWERTY Inserts

a42852

RESET	ESC TAB	HOME	↑	↓	←	→	DEL	BACK SPACE	F5 F1	F6 F2	F7 F3	F8 F4
BREAK	1 !	2 @	3 #	4 \$	5 %	6 ^	7 &	8 *	9 (	0 )	- -	= +
CTRL	Q	W	E	R	T	Y	U	I	O	P	[ {	] }
REPEAT	A	S	D	F	G	H	J	K	L	; :	, "	RETURN
SHIFT	\	Z	X	C	V	B	N	M	, <	. >	/ ?	SPACE

### 34-position Keyboard

The OIT's built-in keyboard features a numeric keypad, cursor control pad, and 15 function keys. The function key legends are also printed on slide-in inserts for easy user customization.

You can define the function keys to represent up to 16 ASCII characters (including escape sequences) for on-line operation.

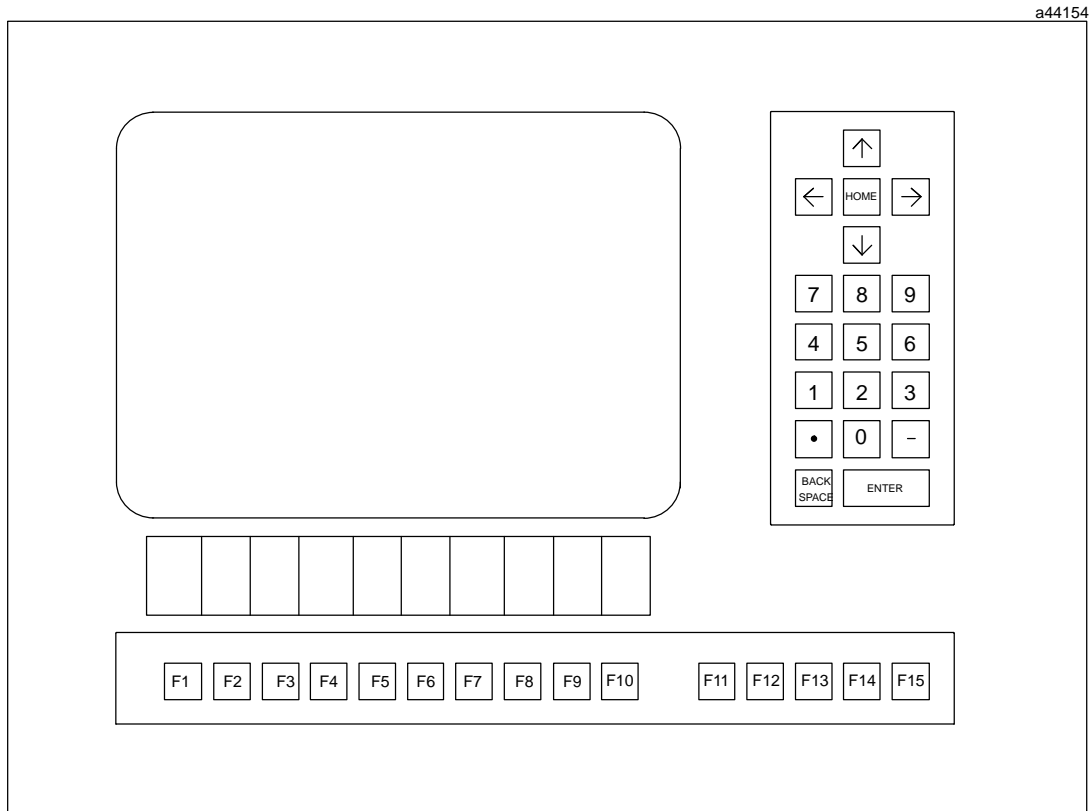

a44154

## IBM PC-compatible Keyboards

During screen programming, and for certain permanent applications, an IBM PC/PCXT-compatible full-travel QWERTY keyboard may be desirable. The OIT supports keyboards designed for use with the IBM Personal Computer or compatible equivalents. There are two connectors on the rear panel of the OIT. Use the round DIN connector with full-sized IBM PC/PC-XT keyboards and the modular phone plug-style connector with portable IBM PC/PC-XT keyboards.

An IBM-compatible keyboard may be connected and used simultaneously with the sealed keyboards. Not all of the special keys on the IBM-compatible keyboard are appropriate for the OIT. The OIT supports IBM function keys F1 through F10; you can use the [Shift]-[F1] through [Shift]-[F6] key combinations to produce F11 to F16; and the OIT supports the Print Screen key.

GE Fanuc Automation offers an IBM PC-compatible full-travel keyboard; IC640PKB201.

## User-Customized Keyboards

The function keys in the numeric and cursor control keypad as well as all of the keys of the 65-position sealed membrane keyboard may be easily removed for custom labeling.

Each character position uses a clear window through which you can view the keyboard legend. The standard legends are preprinted on inserts of .005" thick mylar film. These are inserted into slots located at the bottom of the front surface of the keyboard and at the sides of the numeric keypad. You must remove the keyboard from the OIT front panel to change the inserts.

After you properly install the keyboard, the slots are covered by the keyboard mounting gasket so that it remains totally sealed.

You can label the keyboard inserts to meet your specific application needs. Inserts may be manufactured of any material and any color, but should be about 0.005" thick for proper insertion and keyboard operation. The standard inserts can be used as a guide for the proper size. Any keys that you do not use may be left blank or printed black to match the keyboard overlay foreground colors.

## Specifications

<b>Processor</b>	Z80B
<b>Memory</b>	32K bytes to 192K bytes battery-backed CMOSRAM available.
<b>Front panel finish</b>	Black, textured polyurethane paint standard.
<b>Monochrome</b>	12" diagonal, high-contrast amber
<b>Color</b>	12" diagonal, high-resolution RGB
<b>Window</b>	Gasketed .125" smoked polycarbonate, UV hardcoated, scratch resistant, and non-glare surface
<b>Format</b>	25 lines of 80 characters, 1 to 4 independent status lines
<b>Weight</b>	(depending on keyboard) 12" diagonal monochrome: 32 to 36 lbs. (14.5 to 16.3 kgs.) 12" diagonal color: 39 to 41 lbs. (17.7 to 18.6 kgs.)
<b>Characters</b>	
<b>Set</b>	256 characters consisting of 95 ASCII and 161 graphic characters plus 80 quad size letters, numbers, symbols. ASCII characters can be displayed normal size, double-wide, or quad size.
<b>Formation</b>	5 x 7 dot matrix, except: 5 x 9 dot matrix for lowercase characters with descenders, 8 x 10 dot matrix for graphics
<b>Video Attributes</b>	
<b>Size</b>	12" diagonal: 5.5" high by 8.5" wide
<b>Monochrome</b>	Dim, normal, and highlight video for foreground and background, plus blink and underline
<b>Color</b>	Eight foreground and eight background colors, plus blink
<b>Cursor</b>	None, and blinking or continuous in underline or block forms
<b>Cursor addressing</b>	Relative and direct
<b>Scrolling</b>	Full or split screen
<b>Keyboards</b>	
<b>34-position (Sealed)</b>	Keys in L-shaped configuration around display including 15 function keys, 0 to 9 numeric keys, Enter], Backspace], four cursor control keys, and Home].
<b>65-position, optional (Sealed) (Stand-alone as IC600KD511)</b>	Keys in 5 by 13 rectangular matrix using 0.95" centers and 0.6" square. The 65-position keyboard is available with any of three different inserts: terminal, BASIC, QWERTY.
<b>Full Travel Keyboard, optional (Stand-alone as IC640PKB201)</b>	IBM PC-XT type compatible with DIN connector.
<b>General information</b>	The built-in snap action of the sealed-membrane keyboards generate tactile feedback for input. The surface of all of the keyboards is a matte, UV hardcoated polycarbonate. The OIT accepts IBM PC/PC-XT-compatible keyboards with DIN connector or modular phone plug connector. The IBM PC-AT keyboard is NOT supported.
<b>Operating Environment</b>	
<b>Sealed front panel</b>	Meets NEMA 4 and NEMA 12 specifications
<b>Temperature</b>	0 to 50 degrees Celsius (32 to 122 degrees Fahrenheit)
<b>Humidity</b>	5 to 95% RH, non-condensing
<b>Shock and vibration</b>	5 to 10 Hz, 0.20 inches peak-to-peak 10 to 200 Hz, 1G peak-to-peak
<b>Electrical noise immunity</b>	NEMA showering arc test ICS 2-230. Surge withstand capacity ANSI C37.90A
<b>Certification UL and CSA</b>	
<b>Power Requirements</b>	
<b>12" monochrome</b>	115/230VAC, 50/60 Hz, 45 W
<b>12" color</b>	115 VAC only, 50/60 Hz, 65 W
<b>Communications</b>	
<b>Primary port (DTE)</b>	Serial RS-232C or RS-422. Handshaking by hardware (RTS/CTS) or software (XON/XOFF). Uses DB-25P connector. Serial RS-232C or RS-422.
<b>Secondary port (DCE)</b>	Handshaking by hardware (RTS/CTS) or software (XON/XOFF). Uses DB-25S connector.
<b>Input buffers</b>	256 characters per port
<b>Optical isolation</b>	Serial ports are protected by circuits which provide up to 1,000 volts of line isolation.
<b>Menu-configurable</b>	50 to 38,400 baud transmission rate. 7 or 8 bit characters. 1 or 2 stop bits. Odd, even or no parity. Command sets: ANSI X3.64, VT52, or subset of VT100.

---

## OIT Compatibility

The OIT supports a wide variety of existing hardware and software configurations, therefore it can replace many other terminals.

The OIT is completely compatible with the ANSI X3.64 and VT52 operating modes.

The OIT makes a number of non-ANSI commands available to allow its use in place of a DEC VT100 terminal. A number of differences, however, exist between the OIT and a VT100 terminal. The DEC VT220 series of terminals provide additional capabilities beyond the DEC VT100. The OIT, however, remains compatible with the VT220 terminal. The VT220 offers support for additional function keys, but since you can program the OIT's function keys, you can configure an OIT to emulate the keys on a VT220.

The major differences between the OIT and the VT100 are outlined below:

- OIT and VT100 keyboards differ. This affects special commands that use the cursor keypad.
- The VT100 terminal supports an optional mode of 132 characters per line. The OIT does not support this mode.
- Some of the VT100 terminal's special graphic characters have been replaced by other characters on the OIT. Also the OIT does not support all commands that affect the character set on the VT100.
- Tab stops on the OIT are not programmable.
- The OIT does not support the smooth scrolling mode found on the VT100.
- The OIT addresses all 80 columns of the display in double width mode. The VT100 only addresses 40 columns in double width mode. For example, column 64 on the OIT corresponds to column 32 on the VT100 terminal when in double wide mode. This gives you more flexibility in creating screens than available with a VT100 terminal. In VT100 mode, addressing is the same.

# Chapter 2

## Getting Started

---

---

When you receive your Operator Interface Terminal (OIT) package, you should receive the following items:

- The Operator Interface Terminal (OIT).
- Operator Interface Terminal (OIT) Documentation.

Keep the OIT shipping box and packing materials so that you can safely and efficiently ship the OIT if you need to.

You must supply several items not provided with the OIT:

- A medium-sized, flat-headed screwdriver and a Phillips screwdriver. You will use the screwdrivers for several jobs as you start to use your OIT.
- An IBM PC-compatible keyboard or IBM PC-XT-compatible keyboard. The OIT does not support the IBM PC-AT-compatible keyboard.
- An AC power cord.

### Installing the AC Power

1. Locate the AC power terminal strip on the back of your OIT and remove the yellow terminal block shield.
2. Using a screwdriver, attach the three wires from an AC power cord to the terminals:

Terminal	Wire
L1	Hot
L2	Neutral
L3	Ground

3. Replace the yellow terminal block shield.

### Installing the Battery

1. Locate the small rectangular battery cover plate on the back of the OIT. Remove the two Phillips screws from the plate, and separate the plate from the OIT. Notice how two clips hold the battery on the back of the plate.
2. Locate two sets of battery connections on the logic board just inside the OIT chassis. Plug the mating connector from the battery cable onto one of the connections on the logic board. Make sure that the notched side of the mating connector faces away from you as you plug it in.
3. Put the cover plate back on the OIT and replace the two screws.

## Attaching the Keyboard

The OIT requires the use of an IBM PC-compatible or XT-compatible keyboard; the OIT does not support the IBM AT-compatible keyboard although many AT keyboards can be used as an XT keyboard by setting a switch on the keyboard.

For proper operation, the power to the OIT must be turned off before plugging the keyboard into the OIT or unplugging the keyboard.

Make sure that the OIT is turned off and plug the keyboard into the OIT.

## Powering-up the OIT

Plug in the OIT and turn on the AC power switch on the back of the OIT.

### Caution

**The OIT is designed to operate at 120 Volts AC, 60 Hz. Applying 220 Volts AC damages this unit and voids the user warranty.**

**Make sure that the voltage corresponds to the voltage requirement indicated on the identification label located on the rear panel of the unit.**

After you power-up the OIT, the following display, along with a moving video pattern, appears on your screen:

```
DIAGNOSTICS
INTERNAL:
          00=32K RAM
          01=32K RAM

Testing VRAM, RAM, CRTIC, CTC, SIO, BATTERY, CLOCK, APU Test OK

1JAN08 00:00:00
```

These power-up diagnostics verify the user memory of the unit as well as other internal hardware components.

When the system completes this test, the Main Menu and Main Function Bar of the system appear, or only the Main Function Bar appears. The Main Menu and Main Function Bar appear below:

```

      GE Fanuc Industrial Workstation

F1 SETUP - Setup Workstation for      F6 TOOLS - Transfer files to/from
power-up operation,                   cartridge or host,
run demo program                       maintain internal files

F2 SCREEN- Create or edit             F7 CONFIG- Configure serial
graphic screen files                  ports, execute
                                       diagnostic tests

F3                                     F8 ONLINE- Enter Online
                                       Terminal Mode

F4                                     F9 LOCAL - Emter Local
                                       Terminal Mode

F5 BASIC - Edit OptiBASIC file        F10 RUN  - Run program selected
                                       on Setup Menu

-----
                                MAIN FUNCTIONS
  SETUP  SCREEN          BASIC  TOOLS  CONFIG  ONLINE  LOCAL  RUN
  F1     F2             F3     F4     F5     F6     F7     F8     F9     F10
Power-up Status:  DISPLAY MAIN MENU

```

### Note

The entry under the [F5] BASIC function key, does not appear unless you have the OIT with OptiBASIC (OIT-OptiBASIC).

Depending on the status of your system, only the Main Function Bar may appear at the bottom of the screen, as shown below:

```

-----
                                MAIN FUNCTIONS
  SETUP  SCREEN          BASIC  TOOLS  CONFIG  ONLINE  LOCAL  RUN
  F1     F2             F3     F4     F5     F6     F7     F8     F9     F10
Power-up Status:  DISPLAY MAIN MENU

```

If you do not see the diagnostic display and at least the Main Function Bar when you power-up the system, perform the following steps until it appears:

1. Press the [Ctrl]-1 combination of keys. (Hold the [Ctrl] key down and press the 1 key that appears above the Q on the keyboard. You cannot use the numeric keypad for this operation. Release the keys at the same time.)
2. Press the [Ctrl]-C key combination, pause a second, and then press the [Ctrl]-1 key combination.
3. Turn the contrast knob on the back of the OIT counterclockwise to increase the contrast on the monitor display.
4. Make sure that your OIT has Firmware 3.1 or later installed on the board.

You can always turn the power to the OIT off from the Main Menu or Main Function Bar without losing any of the screens or files that you've created.

## Using the Menu-driven System

The menu-driven system allows you to enter the OptiSCREEN editor, specify parameters for serial communications, configure the system, and transfer screens and files to and from a host. The menu-driven system also gives directory listings of screens and files, and displays variables and their values.

With the menus, you press one of the [F1] through [F10] function keys to make your selection. The system always displays valid function keys in the function bar at the bottom of the screen. After you press the key, the system displays another menu, offers a list of screens or files from which to choose, or executes an operation:

- When the system displays a menu, you press a function key to make another selection.
- When the system offers a list of files from which to choose, you use the cursor control keys (such as [Right] and [Down] on the keypad) to highlight a file and then press the appropriate function key to select the operation you want to perform.
- When the system executes an operation, it completes the process and then returns you to an appropriate menu or selection screen so that you can continue working.

To move between capabilities, you must return to the Main Function Bar. When you return to the Main Function Bar, the system outlines the menu items across the bottom of the screen:

- Usually you can press the [F1] MAIN function key to return to the Main Function Bar. After you press the [F1] MAIN function key, only the Main Function Bar appears across the bottom of the screen.
- The [Ctrl]-1 key combination often returns you to the Main Function Bar.

Within the menu-driven system, the Main Menu or the Main Function Bar appears first:

```

      GE Fanuc Industrial Workstation

F1 SETUP - Setup Workstation for      F6 TOOLS - Transfer files to/from
           power-up operation,        cartridge or host,
           run demo program           maintain internal files

F2 SCREEN- Create or edit            F7 CONFIG- Configure serial
           graphic screen files       ports, execute
                                       diagnostic tests

F3                                           F8 ONLINE- Enter Online
                                       Terminal Mode

F4                                           F9 LOCAL - Emter Local
                                       Terminal Mode

F5 BASIC - Edit OptiBASIC file        F10 RUN  - Run program selected
                                       on Setup Menu

-----
                                MAIN FUNCTIONS

SETUP  SCREEN          BASIC  TOOLS  CONFIG  ONLINE  LOCAL  RUN
F1     F2             F3     F4     F5     F6     F7     F8     F9     F10
Power-up Status:  DISPLAY MAIN MENU

```

The following list describes the Main Menu or Function Bar choices and their capabilities:

**[F1] SETUP:** Specifies what operation the OIT performs on power-up or when you press the [F10] RUN key while using the system.

**[F2] SCREEN:** Enters the OptiSCREEN screen editor to create or edit a screen.

**[F6] TOOLS:** Enters the utility menu so that you can transfer screens, files, and data to and from the IBM-compatible host. This item also allows you to maintain internal files.

**[F7] CONFIG:** Specifies the serial communications parameters, ports, and diagnostic tests for the OIT.

**[F8] ONLINE:** Places your OIT in Online mode for communication with the host.

**[F9] LOCAL:** Places your OIT in Local mode for testing and limited operation.

**[F10] RUN:** Runs the program named on the status line at the bottom of the screen. Specify the program with the [F1] SETUP menu item from the Main Menu.

## Using the Configuration Menu

Each of the Main Menu items leads you to another menu or set of selections. To start using your OIT, you need to use the Configuration Menu.

1. To enter the Configuration Menu, press the [F7] function key at the Main Function Bar. The Configuration Menu appears; for example:

```

                                Firmware Release X.X                11JAN89
MODE                             ANSI          NO ECHO          SEND ANY CASE
DATE/TIME                         11JAN89    DISPLAY          14:51  DISPLAY
END LINE/COLOR                    NO WRAP    NO AUTO LF        COLOR
CURSOR/SCREEN                     BLINKING  BLOCK           CRT SAVER OFF
STATUS/CONTROLS                   ONE       7 BIT CONTROLS
PRINT SCREEN                       KEY OFF    GENERIC ASCII    PORT 1
KEYBOARD                           2 BASIC
PORT 1                             9600 NONE 8 BIT 1 STOP SOFT PT TO PT
PORT 2                             9600 NONE 8 BIT 1 STOP SOFT PT TO PT
PORT 3                             9600 NONE 8 BIT 1 STOP SOFT
CONFIDENCE TESTS                   DIAGNOSTIC

-UP-      -DOWN-      -LEFT-      -RIGHT-      -SELECT-      -PERFORM-
UP KEY    DOWN KEY    LEFT KEY    RIGHT KEY    HOME          ENTER

-----
MAIN      F2      F3      F4      SAVE  RECALL      F7      F8      F9      RUN
F1       F1      F2      F3      F4      F5      F6      F7      F8      F9      F10
Power-up Status:  DISPLAY MAIN MENU

```

The Configuration Menu specifies the serial communications parameters, ports, and diagnostic tests for the OIT. Use the cursor control keys to move through the items. Use the [Spacebar] to toggle through the available option settings for an item before saving the settings, as described below.

2. If the cursor does not already cover the first field on the screen (displaying the ANSI setting shown above), use the cursor control keys (such as [Up] and [Left] on the keypad) to move the cursor to that field.
3. Press the [Spacebar] several times to display the available settings: *ANSI, VT100, and VT52*. Leave the *MODE* item on the *ANSI* setting during the “Getting Started” chapter.
4. Use the [Down] key to move to the first field on the *KEYBOARD* line.
5. Press the [Spacebar] to move through the available settings: *1 TERMINAL, 2 BASIC, 3 MINI (not supported), 4 QWERTY, 5 PROGRAMMABLE* and *6 EUROSTYLE (not supported)*. Leave the status field on the *2 BASIC* setting during most of this part of the “Getting Started” chapter.
6. Check the rest of the settings on the Configuration Menu and, if any of them are different than the ones shown above, change them to match the above settings.
7. Press the [F5] SAVE function key to store the settings you just specified. The system highlights the *SAVE* function key as it saves the menu. The system uses the stored settings as the default whenever you power-up the system.
8. Press the [F1] MAIN function key to return to the Main Function Bar.

Now you are ready to set the default operating mode the OIT uses when you power-up the system.

# Specifying the Default Setup

In this section, you specify the Main Menu as the default operating mode for your OIT. After you press the [F1] MAIN function key, the system displays the Main Function Bar:

```

                                Firmware Release X.X           11JAN89
MODE                             ANSI      NO ECHO      SEND ANY CASE
DATE/TIME                        11JAN89  DISPLAY      14:51  DISPLAY
END LINE/COLOR                   NO WRAP  NO AUTO LF    COLOR
CURSOR/SCREEN                    BLINKING BLOCK CRT SAVER OFF
STATUS/CONTROLS                  ONE      7 BIT CONTROLS
PRINT SCREEN                     KEY OFF  GENERIC ASCII PORT 1
KEYBOARD                         2 BASIC
PORT 1                           9600 NONE 8 BIT 1 STOP SOFT PT TO PT
PORT 2                           9600 NONE 8 BIT 1 STOP SOFT PT TO PT
PORT 3                           9600 NONE 8 BIT 1 STOP SOFT
CONFIDENCE TESTS                 DIAGNOSTIC

-UP-      -DOWN-      -LEFT-      -RIGHT-      -SELECT-      -PERFORM-
UP KEY    DOWN KEY   LEFT KEY    RIGHT KEY    HOME         ENTER

-----
                MAIN FUNCTION
  SETUP  SCREEN  F3      F4      F5      TOOLS  CONFIG  ONLINE  LOCAL  RUN
   F1    F2      F3      F4      F5      F6     F7     F8     F9     F10
Power-up Status:  DISPLAY MAIN MENU

```

Notice that after you press the [F1] MAIN function key, the Main Function Bar appears at the bottom of the screen but that the previous screen, the Configuration Menu in this case, remains in the top portion of the screen. Regardless of the screen shown at the top, the system allows you to press the function keys listed at the bottom of the screen to execute the operations they describe:

1. To enter the Setup Menu, press the [F1] SETUP function key from the Main Function Bar. The Setup Menu specifies the program or status that the system uses when you power-up the system or when you press the [F10] RUN key within the system. The Setup Menu appears below:

```

SETUP

  Workstation Power-up Status:

                MAIN MENU

1 - Display main menu
2 - Enter ONLINE operation
3 - Enter LOCAL operation
4 - Run MYSTART application
5 - Run application
6 - Run application

-----
MAIN
F1    F2    F3    F4    F5    F6    F7    F8    F9    RUN
Power-up Status:  MAIN MENU

```

2. If the Setup Menu does not already specify *Main Menu* at the top of the menu and in the *Power-up status* line at the bottom of the menu, press the *1* key (in the numeric row above the letter Q or on the numeric keypad) to set this status.
3. To save and use the menu, press the [F1] MAIN function key or the [F10] RUN function key. When you press the [F1] MAIN function key, only the Main Function Bar appears at the bottom of the screen. When you press the [F10] RUN function key, the Main Function Bar appears on the bottom of the screen and the short descriptions for the various functions appear above the bar.

Now you are ready to enter the OptiSCREEN editor and create your first screen file.

## Using the OptiSCREEN Editor

In this section of the “Getting Started” chapter, you create and display four screen files: a text screen file, a graphics screen file, a relative graphics screen file, and a screen file that calls the relative graphics screen file.

1. Press the [F10] RUN function key and the system displays the Main Menu and Function Bar. If you press the [F1] MAIN function key, only the Main Function Bar appears at the bottom of the screen:

```

      GE Fanuc Industrial Workstation

F1 SETUP - Setup Workstation for          F6 TOOLS - Transfer files to/from
           power-up operation,           cartridge or host,
           run demo program              maintain internal files

F2 SCREEN- Create or edit                 F7 CONFIG- Configure serial
           graphic screen files           ports, execute
                                           diagnostic tests

F3                                           F8 ONLINE- Enter Online
                                           Terminal Mode

F4                                           F9 LOCAL - Emter Local
                                           Terminal Mode

F5 BASIC - Edit OptiBASIC file            F10 RUN  - Run program selected
                                           on Setup Menu

-----
                                MAIN FUNCTIONS
  SETUP  SCREEN  BASIC  TOOLS  CONFIG  ONLINE  LOCAL  RUN
  F1     F2     F3     F4     F5     F6     F7     F8     F9     F10
Power-up Status:  DISPLAY MAIN MENU

```

2. To enter the OptiSCREEN editor for creating and editing OptiSCREEN screen files, press the [F2] SCREEN function key.

## Creating a Text Screen File

After you press the [F2] SCREEN function key at the Main Function Bar, the Screen File Editor Directory appears. If a screen file appears (with the *Editing prompt* at the bottom of the function bar), press the [F10] DIR function key to obtain the directory, as shown below:

```

      Screen File Editor - Directory
TEST1

                                     SELECT FILE:
-----
MAIN   SYNTAX  EDIT   SHOW   RENAME  COPY   DELETE  RUN
F1     F2      F3     F4     F5      F6     F7      F9     F10
Power-up Status:  DISPLAY MAIN MENU

```

1. Look in the directory for a file named *TEST1*. If the file does not exist, move to step 2. If the file exists, delete it:
  - A. Use the cursor control keys ([Right] and [Down], for example) to move the cursor to cover the screen file named *TEST1* in the directory. The name also appears in the *Select file* prompt at the bottom of the screen.
  - B. Press the [F8] DELETE function key to delete the screen file.

After deleting the file, the system returns you to the Screen File Editor Directory so that you can continue working.

2. If the directory is empty, use the keyboard to enter the name *TEST1* and then press the [F3] EDIT function key or press the [Enter] key. If another file name appears in the directory, use the [Backspace] key to delete the name, one character at a time, and then enter the name *TEST1* before pressing the [F3] EDIT function key or the [Enter] key.
3. The screen file editor places you in an empty screen:

```

-
END

                                     SELECT FILE:
-----
MAIN   STEP    SHOW   SAVE   ABORT  DELETE  INSERT  DIR
F1     F2      F3     F4     F5     F6     F7      F8     F9     F10
Editing: TEST1

```

Enter the following commands to generate the screen file. Feel free to enter the name of your company between quotes where *YOUR COMPANY* appears below:

```
'Test1 - Text file
CLEAR SCREEN
MOVE TO 10, 10
QUAD SIZE
DISPLAY "TEST 1"
BLUE
/WHITE
MOVE TO 16, 10
DISPLAY "YOUR COMPANY"
EXIT QUAD
```

```
—
END
```

---

```
MAIN      STEP      SHOW      SAVE      ABORT  DELETE  INSERT  DIR
F1        F2        F3        F4        F5        F6        F7        F8        F9        F10
Editing:  TEST1
```

If you are using a monochrome OIT, enter the following commands instead of the *RED* and */BLUE* commands:

```
BRIGHT
/DIM
```

Information about the individual commands helps you understand the purpose of this file:

- The first line, *'Test1 - Text file*, demonstrates a comment line. Starting a line with an apostrophe (the character two keys to the right of the L key) makes any line a comment, or a remark, for the OptiSCREEN file. Comments help document the purpose of commands and statements in individual files. Also, when you make the first statement of a screen file a comment, the comment identifies the file when you generate a file directory.
- The *CLEAR SCREEN* command clears the entire OIT screen and resets all attributes. You see this command at the beginning of files and whenever you want to “start fresh” in a system.
- The *MOVE TO 10, 10* and the *MOVE TO 16, 10* commands cause the text or graphics that follow to appear in a specified location. The first MOVE command starts the display of text at row 10 and column 10 on the screen. The second command starts the display of text at row 16 and column 10. An OIT includes 24 rows, numbered from the top of the screen to the bottom. It includes 80 columns, numbered from the left side of the screen to the right.
- The *QUAD SIZE* and *EXIT QUAD* command pair are “character attribute commands.” They affect the appearance of all text and graphics that fall between the two commands. In general, a character fills a single cell so that it appears one row tall and one column wide. A quad size character appears four rows tall and four columns wide. Quad size characters appear in an uppercase (capitalized) form only.

- The *DISPLAY* command specifies the text that appears on the screen. The first *DISPLAY* command specifies the name of the file, “TEST1,” and the second specifies the name of “YOUR COMPANY.” As noted above, quad size characters appear in uppercase only, so you must enter capitalized text.
- Like *QUAD SIZE* the *BLUE* and */WHITE* commands (or the *BRIGHT* and */DIM* commands) are character attribute commands; they affect the appearance of all text and graphics that fall after the commands. In this case, *BLUE* (or *BRIGHT*) specifies that the text and graphics appear in blue (or bright mode) on the screen; */WHITE* (or */DIM*) specifies that the text and graphics appear on a white background (or a dim background). Other colors include *RED*, *YELLOW*, *CYAN* (or light blue), *GREEN*, and *MAGENTA* (or purple). On monochrome monitors, you specify *BRIGHT*, *DIM*, and *NORMAL*. By placing a slash (/) immediately before these colors or modes, you specify the background color or mode.
- The system automatically places the required *END* command on the screen. When you display the screen file again, the system deletes the blank line before the *END* command.

As you entered these commands, you may have noticed some interesting things:

- The system automatically capitalizes the commands for you when you press the [Enter] key to move to a new line. It does not, however, capitalize text that appears within quotes.
- When you press the [Enter] key, the system also correctly spells out commands that you abbreviated or misspelled as you entered them.
- You can use the cursor control keys to move through the screen file and make corrections to the text.
- You can press the [F9] *INSERT* function key to insert a new, blank line into the middle of the file. (The [Ctrl]–[Ins] key combination also performs this function.)
- You can press the [F8] *DELETE* function key to delete the line that the cursor currently covers in the file. (The [Ctrl]–[Del] key combination also performs this function.)
- You can press the [Ins] key to change from replacement, or overwrite, mode to insertion mode and add new text to the file. In insertion mode, existing text shifts to the right to make room for the new text.
- You can press the [Del] key to delete the character that the cursor currently covers.
- If you enter the first character or characters of a screen command and then pause before completing the command, the system displays a help screen that outlines the syntax for the commands that begin with the letter or letters you’ve entered.

- 4. To display the screen file at your OIT, press the [F4] SHOW function key:

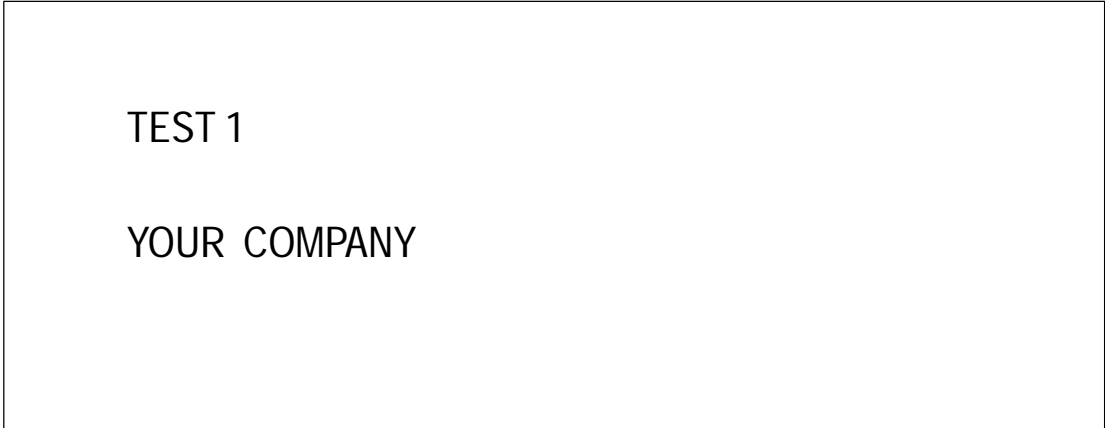

This shows how the screen appears when you call it from an external device or call it from another program.

- 5. Press any key to return to the screen file for further editing:

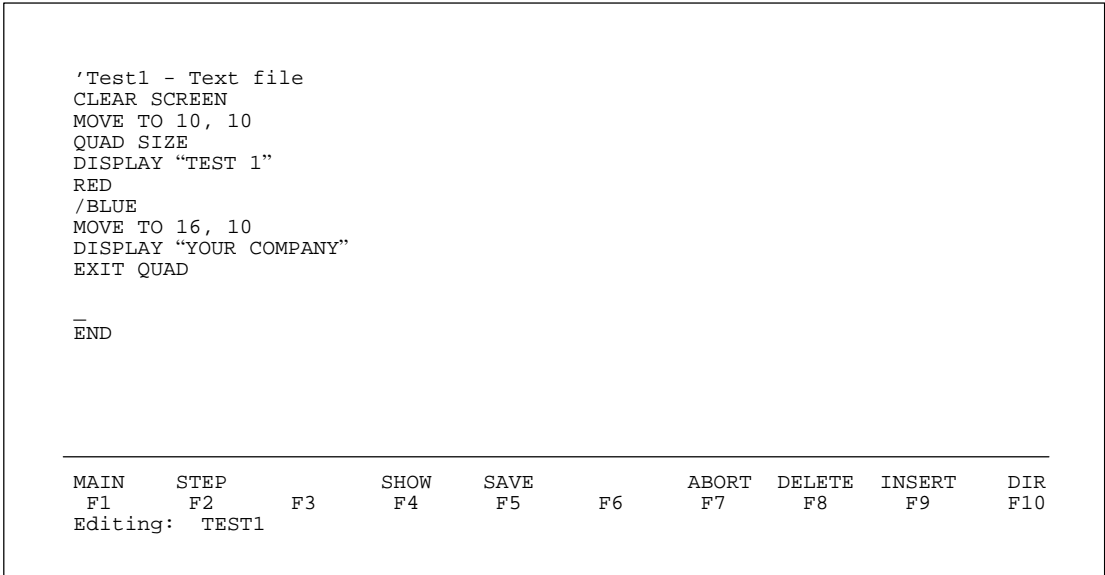

At this point, you can add commands to the screen file or you can make changes to the existing commands in the screen file. Press the [F4] SHOW function key to display the screen again, and press any key to return to the screen file for further editing.

- 6. Press the [F5] SAVE function key to save the screen file you just created. The system highlights the SAVE function key as it saves the file.
- 7. Press the [F10] DIR function key to return to the Screen File Editor Directory. Notice that the TEST1 screen file now appears in the directory.

You are now ready to create another screen file or perform another function.

### Creating a Graphic Screen

The first screen file that you created showed two lines of text. In this example you create a simple graphic display. To begin, examine the Screen File Editor Directory; for example:

```

Screen File Editor - Directory

TEST1

                                SELECT FILE:
-----
MAIN   SYNTAX   EDIT   SHOW   RENAME   COPY   DELETE   RUN
F1     F2       F3     F4     F6       F7     F8       F9     F10
Power-up Status:  DISPLAY MAIN MENU

```

1. Look in the directory for a file named *TEST2*. If the file does not exist, move to step 2. If the file exists, highlight it with the cursor and press the [F8] DELETE function key to delete it.
2. If necessary, use the cursor control keys to highlight the *TEST1* file name. Use the [Backspace] key to delete the last character of the *TEST1* file name and enter the number 2, creating a screen file named *TEST2*. Press the [F3] EDIT function key or the [Enter] key.
3. The screen file editor places you in an empty screen. Enter the following commands to generate the screen file:

```

'Test2 - Graphic file
MOVE TO 10, 20
BOX 8 x 8
DISPLAY "TEST 1"
LEFT 4
QUAD SIZE
DISPLAY "e"
EXIT QUAD

END

-----
MAIN   STEP   SHOW   SAVE   ABORT   DELETE   INSERT   DIR
F1     F2       F3     F4     F5     F6       F7       F8       F9       F10
Editing: TEST2

```

Several new commands and different uses of old commands appear in this example:

- The *BOX* command draws a box on the screen. In this case, the box is 8 rows tall and 8 columns wide. The system draws boxes from the lower left-hand corner of the box. That is, you use the *MOVE TO* command to move to a specific location on the screen, and the *BOX* command draws up a specified number of rows and to the right a specified number of columns.
  - The *LEFT* command moves the cursor left a specified number of columns. In this case, the cursor moves to the left of the box 4 columns, the width of one quad-sized character. OptiSCREEN also offers a *RIGHT* command, an *UP* command, and a *DOWN* command.
  - The lowercase *e* in the *DISPLAY* command appears as a quad-sized graphic character rather than a text character. This occurs since uppercase quad size characters generate text and lowercase quad size characters generate graphics characters.
4. To display the screen file at your OIT, press the [F4] *SHOW* function key. The lowercase *e* generates the graphic symbol often used for a pump on a diagram. Note the location of the graphic and the box.
  5. Press any key to return to the screen file for further editing. At this point, you can make changes to the existing commands in the screen file.
  6. Press the [F5] *SAVE* function key to save the screen file you just created. The system highlights the *SAVE* function key as it saves the file.
  7. Press the [F10] *DIR* function key to return to the Screen File Editor Directory.

You can now perform another function at the OIT.

## Changing a Screen File from Absolute to Relative

In this part of “Getting Started,” you change screen file *TEST2* to make it a relative screen file. (Descriptions of “absolute” and “relative” files appear below.) In the next part of this chapter, you use the changed relative screen file. To begin, move to the Screen Editor File Directory:

1. Highlight the file named *TEST2* with the cursor and press the [F3] *EDIT* function key or the [Enter] key. The screen editor places you in the *TEST2* screen file.

2. Delete the second line in the file (*MOVE TO 10, 20*). To do this, move the cursor to the second line and press the [F8] DELETE function key to delete it. After the deletion, the file looks like this:

```
'Test2 - Graphic file
BOX 8 x 8
DISPLAY "TEST 1"
LEFT 4
QUAD SIZE
DISPLAY "e"
EXIT QUAD

END
```

---

MAIN	STEP		SHOW	SAVE		ABORT	DELETE	INSERT	DIR
F1	F2	F3	F4	F5	F6	F7	F8	F9	F10

Editing: TEST2

This is now a relative graphic screen file. The commands in the file do not display the output from the file in an absolute position; the commands display the output in any location that you specify. Notice that the file does not contain the CLEAR SCREEN command but contains both the QUAD and EXIT QUAD commands.

An example of how to display this relative file appears in the next section of this chapter.

3. Press the [F5] SAVE function key to save the *TEST2* screen file. The system highlights the *SAVE* function key as it saves the file.
4. Press the [F10] DIR function key to return to the Screen File Editor Directory.

You can now generate the screen file that calls the relative screen file.

### Calling a Screen File from Another Screen File

In this section of the chapter, you call the relative screen file that you just created from another screen file. To begin, move to the Screen Editor File Directory:

1. Look in the directory for a file named *TEST3*. If the file does not exist, move to step 2. If the file exists, highlight it with the cursor and press the [F8] DELETE function key to delete it.
2. Use the [Backspace] key to delete the last character of the *TEST2* file name and enter the number 3, creating a screen file named *TEST3*. Press the [F3] EDIT function key or the [Enter] key.

3. The screen file editor places you in an empty screen. Enter the following commands to generate the screen file:

```
'File 3 - Calling another screen file
CLEAR SCREEN
RED
MOVE TO 10, 10
DISPLAY FILE TEST2
BLUE
MOVE TO 14, 20
DISPLAY FILE TEST2
YELLOW
MOVE TO 18, 30
DISPLAY FILE TEST2

-

END
```

---

MAIN	STEP		SHOW	SAVE		ABORT	DELETE	INSERT	DIR
F1	F2	F3	F4	F5	F6	F7	F8	F9	F10
Editing: TEST1									

If you are using a monochrome OIT, instead of the *RED*, *BLUE*, and *YELLOW* commands, specify the commands as *BRIGHT*, *NORMAL*, and *DIM*, respectively.

The *DISPLAY FILE* command in this screen file causes the system to display the contents of screen file *TEST2* in the locations, and in the colors or modes, that you specify.

4. To display the screen file at your OIT, press the [F4] SHOW function key. Note the location and color of the graphics and the box as they appear on the screen.
5. Press any key to return to the screen file for further editing. At this point, you can make changes to the commands in the screen file.
6. Press the [F5] SAVE function key to save the screen file. The system highlights the *SAVE* function key as it saves the file.
7. Press the [F10] DIR function key to return to the Screen File Editor Directory.

# Creating a Sample Screen Format

A sample screen format is shown in the figure below. The sample format can be created by typing in the program which is listed after the figure. The format includes a variety of OptiSCREEN statements to help you become familiar with the overall characteristics of screen programming.

To execute the sample screen that follows, select the keyboard type you would be using for normal operations.

### Note

A screen may not be displayed correctly if the configuration settings when it was created are different from when it is recalled: for example, if type 5 keyboard is selected at the time of creation and type 1 is selected when recalled. If the configuration needs to be changed while on-line, be sure to reset it to the proper state before displaying a new screen.

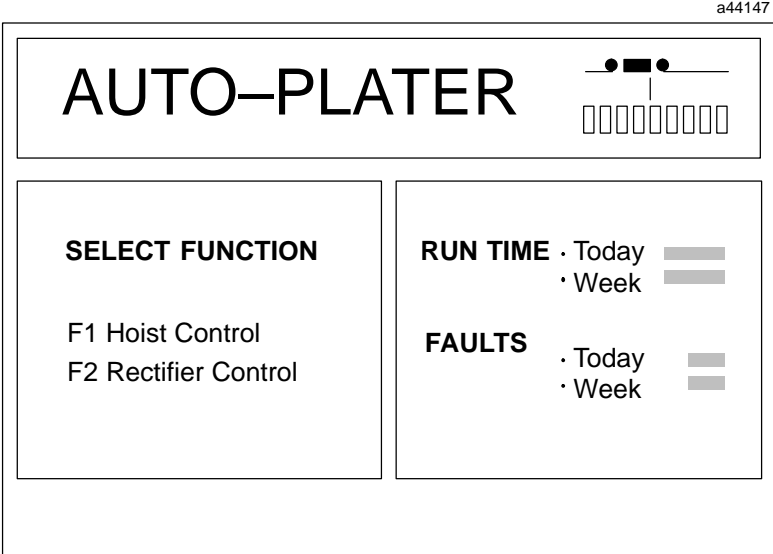

Figure 2-1. Sample Screen Format

## The Sample Program

Comments explaining how the sample program works are included in the listing. Each of the commands used in the sample program are explained in full in Chapter 5, OptiSCREEN Command Reference. The recommended method for entering the program is as follows.

1. Enter a single block of program lines at a time; the blocks are separated in the listing by a blank comment line.
2. After entering a block of lines, press the View Key (F6) to display the part of the program entered. To study how the program is working, switch back and forth between the display of the screen and its program by alternately pressing the View Key (F6) and the Edit Key (F5).
3. Re-enter Edit, type in the next block of lines, and repeat the procedure above.

```
'Sample Screen File
,
RESET LINE ATTRIBUTES
CLEAR SCREEN
,
MOVE TO 7, 1
BOX 7 X 80
MOVE TO 5, 5
QUAD SIZE
DISPLAY "AUTO-PLATER"
EXIT QUAD
,
MOVE TO 2, 59
DISPLAY "_____ "
MOVE TO 3, 64
DISPLAY "|"
SUPPLEMENTAL
MOVE TO 2, 61
DISPLAY "~pp~"
MOVE TO 4, 59
DISPLAY "lklklklklklklk"
MOVE TO 5, 59
DISPLAY "mjmjmjmjmjmjmj"
EXIT SUPPLEMENTAL '
MOVE TO 20, 1
BOX 12 X 38
MOVE TO 11, 4
DOUBLE WIDE
BRIGHT
BLINK
DISPLAY "SELECT FUNCTION"
EXIT DOUBLE WIDE AND BLINK
RESET ATTRIBUTES
MOVE TO 14, 8
DISPLAY "F1 Hoist Control"
MOVE TO 16, 8
DISPLAY "F2 Rectifier Control"
,
```

This is the Screen Title.

These statements draw the box for the screen heading and display the words AUTO-PLATER in Quad size letters. You must use capital letters.

These statements draw the symbol for the Auto-Plater using normal ASCII characters and characters in the Supplemental character set. Be sure to note that the Supplemental character set letters are lower case. See Appendix B for a graphic representation of the Supplemental characters.

These statements make up the Select Function area. The DOUBLE WIDE, BRIGHT, AND BLINK Commands are used to emphasize the action to be taken.

```

,
MOVE TO 20, 43
BOX 12 X 38
MOVE TO 11, 45
DOUBLE WIDE
BRIGHT
DISPLAY "RUN TIME"
MOVE TO 15, 45
DISPLAY "FAULTS"
RESET ATTRIBUTES
SUPPLEMENTAL
MOVE TO 11, 65
DISPLAY "~"
MOVE TO 12, 65
DISPLAY "~"
MOVE TO 15, 65
DISPLAY "~"
MOVE TO 16, 65
DISPLAY "~"
EXIT SUPPLEMENTAL
MOVE TO 11, 67
DISPLAY "Today"
MOVE TO 12, 67
DISPLAY "Week"
MOVE TO 15, 67
DISPLAY "Today"
MOVE TO 16, 67
DISPLAY "Week"
,
/DIM
MOVE TO 11, 74
DISPLAY "{ENQ}{ENQ}{ENQ}{ENQ}{ENQ}"
MOVE TO 12, 74
DISPLAY "{ENQ}{ENQ}{ENQ}{ENQ}{ENQ}"
MOVE TO 15, 76
DISPLAY "{ENQ}{ENQ}{ENQ}"
MOVE TO 16, 76
DISPLAY "{ENQ}{ENQ}{ENQ}"
,
LOAD FUNCTION KEY 1 WITH "B"
LOAD FUNCTION KEY 2 WITH "C"

```

These statements form the Display RUN TIME and FAULTS area of the screen.

These statements are part of the Data Fill operations explained in Chapter 5. The Data Fill operations are used to make it easier for the host to place dynamic data in different locations on the screen. The /DIM command is only included here to show where data from the host will be displayed. Normally, the Data Fill statements would be a separate file from the rest of the screen.

These commands load function keys F1 and F2 with the characters "B" and "C" respectively.

---

## Now That You've Started

This chapter outlined a number of the basic capabilities of the OIT. The rest of this guide and other documentation from GE Fanuc Automation expand on the information presented here:

- Chapter 3 of this guide, "Installation," describes the physical and electrical requirements of the OIT.
- Chapter 4, "Operation" describes menus and screens that the system provides, and outlines the steps you take to use the system.
- Chapter 5, "OptiSCREEN Command Reference" completely describes the OptiSCREEN commands.
- The appendixes found at the end of this guide contain information about the physical measurements of the OIT and the symbols available in the system.

# Chapter 3

## Installation

---

---

GE Fanuc Automation ships all Operator Interface Terminals (OITs) pre-tested and configured for the most popular modes of operation. To operate the OIT, you must mount the unit, supply AC power, and connect a serial communications cable. This section explains hardware installation of the OIT:

- How to physically mount the OIT.
- How the rear panel connections for the power, bell, reset, and battery components work.
- How to prepare the electrical connections for communication with the OIT.
- How to confirm the memory and jumpers on the OIT logic board.

It also shows the locations for the adjustments of the CRT display.

In addition to requiring a compatible electrical interface between your OIT and the host or PLC system, you must also check the software configuration of the OIT for compatibility. More information about the software and its configuration appears in Chapter 4, "Operation."

### Mounting the OIT

Install your OIT in a standard 19" industrial rack or in a special panel cutout for the unit. When properly mounted, the OIT maintains its NEMA 4 and NEMA 12 ratings.

Refer to Appendix A for the required panel cutout and mounting holes for installing the OIT. The OIT uses 10-32 mounting studs.

#### Caution

**To avoid damaging the studs and the front panel, do not over-tighten the nuts on the mounting studs. This damage is not covered by the warranty.**

You should keep the OIT box and packing materials so that you can use them if the unit ever needs to be shipped again.

## Rear Panel Connections

The lower rear of the OIT chassis contains all the connections you need during installation.

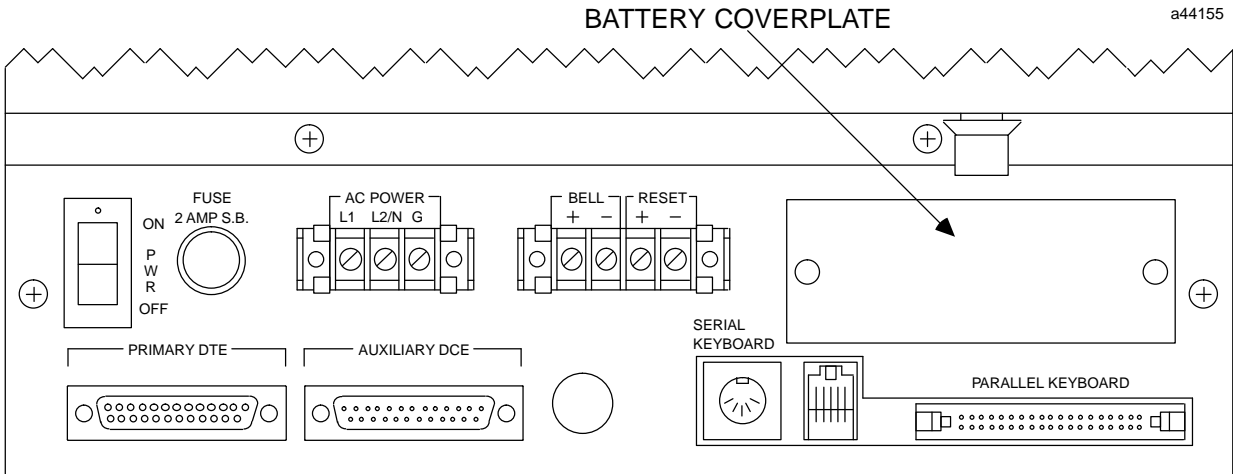

Figure 3-1. Rear View of the OIT

A description of each of the items shown here appears in this chapter.

## AC Power

You must supply your own AC power cord to attach power to the OIT. The OIT is designed to operate at 120 Volts AC, 60 Hz. The three terminals use the following designations.

Terminal	Wire
L1	Hot
L2	Neutral
L3	Ground

**Caution**

**Applying 220 Volts AC damages this unit and voids the user warranty. Make sure that the voltage corresponds to the voltage requirement indicated on the identification label located on the rear panel of the unit. Consult the factory if you require a different voltage.**

# Bell Output Wiring

The OIT gives you the option of manipulating a user-supplied external bell instead of the OITs internal bell.

Two screw terminals, labeled *BELL (+)* and *BELL (-)*, exist at the rear of the OIT. The positive screw terminal is connected internally to the OIT +12 volt supply. The negative screw terminal is connected internally to a solid-state switch (open collector transistor) which is connected to the OIT logic ground. When the OIT receives an ASCII BEL character, or [Ctrl]-G, the system closes the solid-state switch for approximately one half second. The following diagram shows the bell output wiring for a OIT.

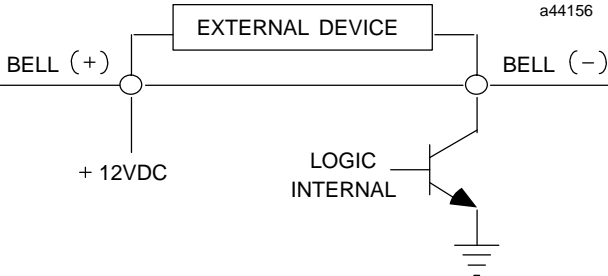

Figure 3-2. Bell Output Wiring

This configuration allows a direct interface to a solid-state audible device, a solid-state relay, or a DC input to a programmable controller.

You may optionally provide your own DC voltage source to the external device with the following steps:

- Connect the positive side of the voltage source to the external device.
- Connect the negative side of the external device to the negative *BELL (-)* screw terminal.
- Connect the negative side of the voltage source to the negative *RESET (-)* screw terminal for the output.

In this case, you do not make any connection to the positive *BELL (+)* screw terminal.

**Caution**

The bell draws a maximum of 50 mA of current from the OIT +12 volt supply. You can use a maximum of 30 volts DC and 50 mA of current with an external supply. To avoid damaging the system, you must use optically isolated solid-state relays if the bell requires higher voltages, currents, or AC operation.

**Caution**

The bell output circuitry is not isolated from the OIT logic circuitry, and is not fused or current-limited. Make sure that the system does not exceed the voltage and current ratings, and that any electrical noise induced in the circuit is not detrimental or damaging to the OIT circuitry. Improper use of the bell output can damage the OIT and is not covered by the warranty.

## Reset Input Wiring

The OIT provides an electrical reset input signal through two screw terminals, labeled *RESET (+)* and *RESET (-)*. When you briefly close a dry contact switch between the two terminals, the OIT resets itself to a power-up condition and performs a “warm boot.”

The reset switch that you supply must be a momentary switch only. If you attach a PLC to the reset input terminals, the PLC must supply a connection for a short burst only.

### Caution

**Applying a signal for an extended period of time through the reset input terminals can severely damage the OIT circuitry.**

## Battery Replacement

The OIT uses a lithium battery to power the built-in clock and calendar, and to maintain the user memory for screens and data files. The battery has a nominal shelf life of five years, and maintains the user memory for up to a year depending upon the amount of memory installed.

### Warning

**Lithium batteries cannot be recharged. Do not discard the lithium battery in fire. Do not short the battery. The battery may burn or release hazardous materials if damaged. Replace the battery with an identical lithium battery.**

The battery assembly consists of a battery with a short cable and a mating connector.

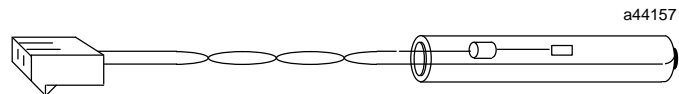

**Figure 3-3. Battery Assembly**

To replace a battery in the OIT, perform the following steps. You do not have to remove the OIT chassis to perform this operation:

1. Turn off the power to the OIT.
2. Remove the two screws which hold the battery coverplate on the back of the OIT.
3. Two clips hold the old battery to the back of the battery coverplate. Disconnect the old battery from the clips on the battery coverplate.
4. A pair of two-position connections exist inside the battery coverplate opening on the main logic board. The old battery is attached to one of the two-position connections.

While the old battery remains attached, connect the new battery to the two unused battery connectors on the logic board. Be sure to use the notches on the battery connector to install the battery with the correct polarity. Assuming that the old battery retains some power, this “double battery” allows you to save any data in user memory.

5. Remove the old battery from the battery connector on the logic board.
6. Install the new battery in the clips on the battery coverplate.
7. Replace the battery coverplate on the back of the OIT.

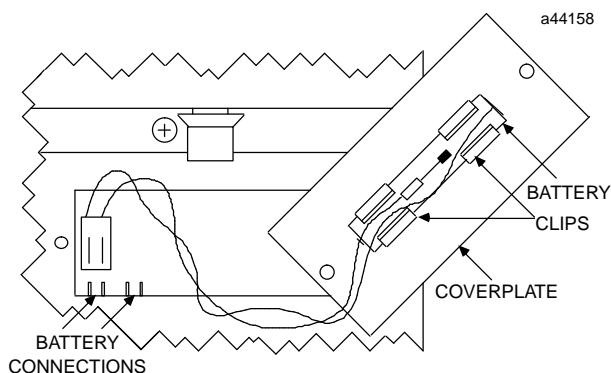

Figure 3-4. Connecting the Battery

## Communication Interface

Your OIT communicates with your computer, programmable controller, or other host device through a serial interface at RS-232C or RS-422 signal levels.

The 25-pin D-connector on the rear of the unit conforms to RS-232C standards. These standards define an asynchronous serial interface, its impedances, and its physical connectors. RS-232C standards place all equipment into one of two general categories:

- DTE, or Data Terminal Equipment, includes most terminals, printers, and other peripherals. DTE devices are commonly called “data terminals.”
- DCE, or Data Communications Equipment, includes many computers and modems. DCE devices are commonly called “data sets.”

The differences between a data terminal and a data set emerge when referring to each device’s input and output connectors, such as the signals labeled “transmitted data” and “received data.”

A cable wired to a DTE at one end and to a DCE at the other end allows all necessary wires to match pin-for-pin at each end. When you connect a DTE device to another DTE device, or you connect a DCE to a DCE, you must cross one or more pairs of signals for proper operation:

- The primary port is configured as a DTE port with signals as shown below. Make sure that your host is either a DCE device or that the connecting cable makes the required signal pair crossovers.
- The secondary port is configured as a DCE port with signals as shown below. Make sure that your peripheral is either a DTE device or that the connecting cable makes the signal pair crossovers.

With RS-232C operation, when you connect a DTE device to a DTE device, or a DCE device to a DCE device, the signals on pins 2 and 3 must be cross connected; for example, pin 2 at one device must be connected to pin 3 at the other. Any required handshaking signals must also be cross connected.

The RS-232 standard defines a number of signals in addition to transmitted and received data. Few devices require all signals to be used, and most require only a few signals. Refer to your host equipment manual for additional information about pins and required signals.

## Port Connector Definitions

Definitions for the serial port connectors appear below. An illustration of each 25-pin connector also appears for reference.

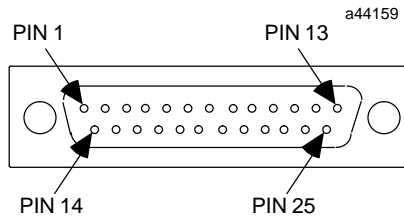

Figure 3-5. Primary Port Using DB-25P Male Connector

Pin	Connection	Pin	Connection
1	Protective(chassis) ground	14	no connection
2	Data Out, RS-232C	15	no connection
3	Data In, RS-232C	16	no connection
4 (a)	RTS (Request To Send) output	17	no connection
5 (b)	CTS (Clear To Send) input	18	no connection
6	no connection	19	no connection
7	Signal Ground	20 (d)	DTR (Data Terminal Ready) out
8	no connection	21	no connection
9 (c)	Terminate RX, RS-422	22	Data In (-), RD(A), RS-422
10	Data In (+), RD(B), RS-422	23	Data Out (-), SD(A), RS-422
11	Data Out (+), SD(B), RS-422	24	no connection
12	no connection	25	Terminate RX, RS-422
13	no connection		

**Notes:**

- (a) Asserted when input buffer space available.
- (b) Must be asserted to allow output if you use hardware handshaking.

Pin 5 on the primary port is used for hardware handshaking during RS-232C operation. If the host equipment does not support the use of this signal and if software handshaking is not selected, then you must connect pin 5 to pin 20 at the OITs connector.

- (c) Must be connected to pin 25 for point-to-point operation or if this OIT falls at the end of a multidrop line.
- (d) Asserted when OIT has power.)

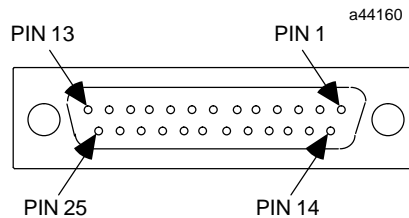

**Figure 3-6. Secondary Port Using DB-25S Female Connector**

Pin	Connection	Pin	Connection
1	Protective(chassis) ground	14	Data In, RS-232C
2	Data In, RS-232C	15	no connection
3	Data Out, RS-232C	16	Data Out, RS-232C
4 (a)	CTS (Request to Send) input	17	no connection
5 (b)	RTS (Clear to Send) output	18	Signal Ground
6	no connection	19	no connection
7	Signal Ground	20	no connection
8 (b)	DCD (Data Carrier Detect)	21	no connection
9 (c)	Terminate RX, RS-422	22	Data In (-), RD(A), RS-422
10	Data In (+), RD(B), RS-422	23	Data Out (-), SD(A), RS-422
11	Data Out (+), SD(B), RS-422	24	no connection
12	no connection	25	Terminate RX, RS-422
13	no connection		

**Notes:**

- (a) Must be asserted to allow output if hardware handshaking used.  
 Pin 4 on the secondary port is used for handshaking during RS-232C operation. If the host equipment does not support the use of this signal, you must connect pin 4 to pin 8 at the OITs connector.
- (b) Asserted when OIT has power.
- (c) Must be connected to pin 25 for point-to-point operation or if this OIT falls at the end of a multidrop line.

## Handshaking with RS-232C Signals

The OIT offers a 256-character input FIFO (first in, first out) buffer for receiving and holding characters until the OIT processes them. In some cases, the FIFO buffer is filled faster than the OIT processes the characters.

“Handshaking” allows the receiving device to direct the sending device to stop transmitting data so that the buffer does not overflow. Generally, you are only required to use handshaking at a rate greater than 9600 baud. Two modes of handshaking, software or hardware, can be selected through system configuration.

## Primary Port

Software handshaking occurs as follows:

- When the FIFO buffer receives 128 characters, the OIT sends XOFF, or [Ctrl]-S, to the host computer as a message to stop transmitting. The system loses incoming characters only after the FIFO buffer receives 256 characters.
- When the OIT processes enough characters so that only 64 characters remain in the FIFO buffer, the OIT sends XON, or [Ctrl]-Q, to the host computer to indicate that it is ready to accept more characters.

You can enable or disable software handshaking via software. On initial power-up, the system disables software handshaking. After you select software handshaking, XON or XOFF codes from the host control the flow of data from the OIT.

The OIT handles hardware handshaking with the following signals:

- The OIT uses the RTS (Request To Send output) signal on pin 4 of the RS-232 interface to indicate when the FIFO buffer can accept additional characters.
- The host asserts the CTS (Clear To Send) signal on pin 5 before the OIT transmits any data.
- The OIT always asserts the DTR (Data Terminal Ready output) signal on pin 20 when power is on.

For either hardware or software handshaking, the host computer must be set up to handle the handshaking information. If the host computer does not support handshaking signals, set the OIT for hardware handshaking, and jumper the DTR output (pin 20) to the CTS input (pin 5) on the OIT. Then, the host ignores the RTS signal from the OIT. The OIT cannot control the flow of data from the host in this situation, so the application program must be written to ensure that the input buffer on the OIT does not overflow.

## Secondary Port

The secondary port performs handshaking in the same manner as the primary port. However, since the secondary port is a DCE port, the CTS and RTS signal directions are reversed. Thus pin 5 (RTS) is an output, and pin 4 (CTS) is an input. On the secondary port, the OIT asserts pin 8 (DCD) whenever power is on.

If your system does not support handshaking, you must jumper pin 4 (CTS, input) to pin 8 (DCD), which performs the same function as installing jumpers on pins 5 and 20 on the primary port. Again, you must take care to avoid overflowing the input buffer on the OIT.

## Handshaking with RS-422 Signals

The OIT does not support the hardware handshaking signals described above as equivalent RS-422 signals. With RS-422 signals, the OIT supports software handshaking when you select it. You should select hardware handshaking if the host supports no handshaking; also you should install jumpers as shown in the wiring diagrams for RS-422 Point-to-Point connections.

You can use RS-422 signals on one port, while you use RS-232 signals on the other port. Be careful not to connect both RS-232 and RS-422 inputs on the same port.

You can, however, use both RS-232 and RS-422 outputs on the same port. To use both outputs, make sure that extra signals from the host equipment are not connected to

RS-422 pins during RS-232C operation and, similarly, that extra signals from the host equipment are not connected to RS-232C pins during RS-422 operation. Refer to the information under the “Multidrop Operations” heading below for information on the use of the OIT using a multidrop RS-422 network.

You must connect RS-422 receiver termination pins at the OIT when using it in a point-to-point configuration. In multidrop configurations, you must connect the termination pins at the OIT farthest from the host:

- You can use the OITs internal termination resistors by connecting pin 9 to pin 25.
- You can use or may be required to use external termination resistors for proper RS-422 operation. External termination resistors are nominally 100 ohms, depending on cable characteristics. At the OIT, connect a resistor between pin 10 and pin 22. At the host, connect a resistor between its Data In(+)RD(B) and Data In(-)RD(A) pins.

Consult your host equipment supplier for additional information.

## Cable and Connector Specifications

The following list provides the specifications for the construction of cables to connect the OIT to a host device:

- Cable connector to primary port: Female, D-subminiature type, Cannon DB-25S with DB110963-3 hood or equivalent (standard RS-232C connector).
- Cable connector to secondary port: Male, D-subminiature type, Cannon DB-25P with DB110963-3 hood or equivalent (standard RS-232C connector).
- Maximum cable length: 50 feet (15 meters) for RS-232C; 4000 feet (1200 meters) for RS-422.
- Overall shield: Recommended. Tie the shield to the chassis ground at one end only. See the wiring diagrams below for more information.
- Minimum wire specification: 24 AWG.
- Cable recommendations: The Belden 9184, the Belden 9302, and the NEC 222P1SLCBT cables provide acceptable operation at data rates of up to 19.2K baud and distances of up to 4000 feet for RS-422 ports.

Refer to your application or device manual for additional information about connections to the host or peripherals.

When using the RS-422 port, you should match the twisted pairs so that both transmit signals make up one twisted pair and both receive signals make up the other twisted pair. If you ignore this crossover, cross talk affecting the performance of the communication system can result from the mismatching.

### Caution

**When routing communications cables outdoors, use transient suppression devices to reduce the possibility of damage due to lightning or static discharge.**

**Also, make sure that both the OIT and the host device to which the OIT is connected are grounded to a common point. Failure to provide a ground can result in serious damage to the equipment if the potential exceeds the isolation voltage rating of the equipment.**

## Typical Cable Wiring Configurations

This section contains cable wiring diagrams for the OIT:

- The diagrams do not cover all possible configurations; but by using the OIT port connector definitions and the manual for the DTE or DCE device connected to your OIT, you should be able to configure the cable for your application.
- All signals, with the exception of the protective ground, are optically isolated from the OIT internal logic. The primary and secondary ports are optically isolated from each other.

The diagrams appear below.

Primary Port to Series Six ASCII/BASIC Module Port 2)

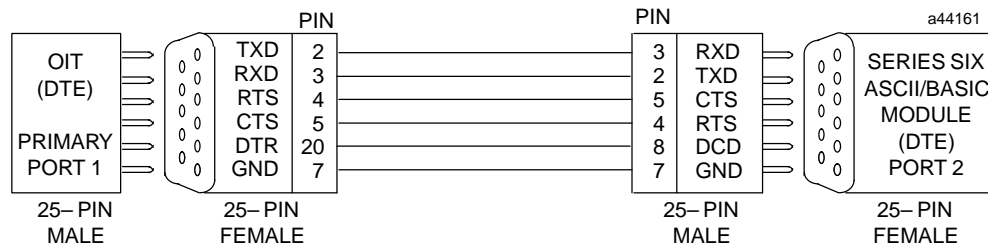

**Figure 3-7. RS-232C Point-to-Point Communication with Handshaking  
(OIT Primary Port to Series Six ASCII/BASIC Module Port 1 or Port 2)**

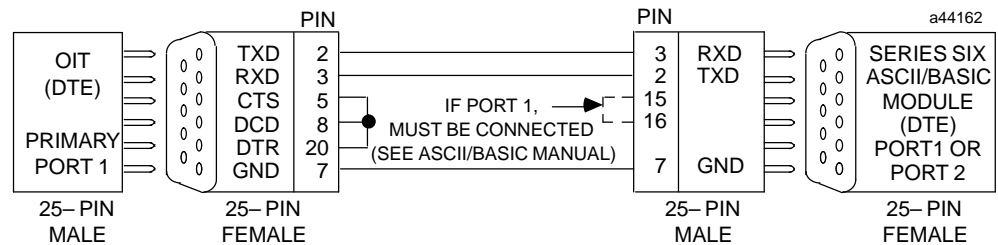

**Figure 3-8. RS-232C Point-to-Point Communication, No Handshaking  
(OIT Primary Port to Series Six ASCII/BASIC Module Port 1 or Port 2)**

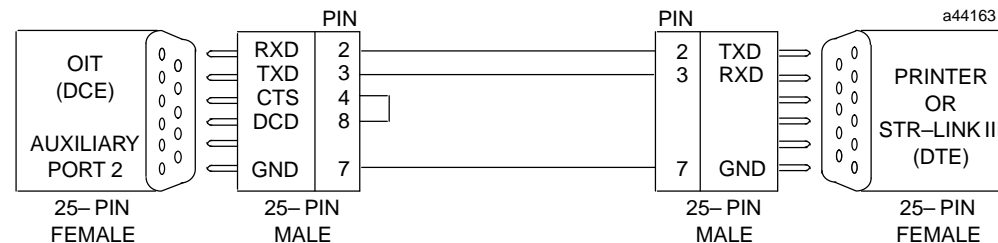

**Figure 3-9. RS-232C Point-to-Point Communication (OIT Secondary Port or STR-LINK III)**

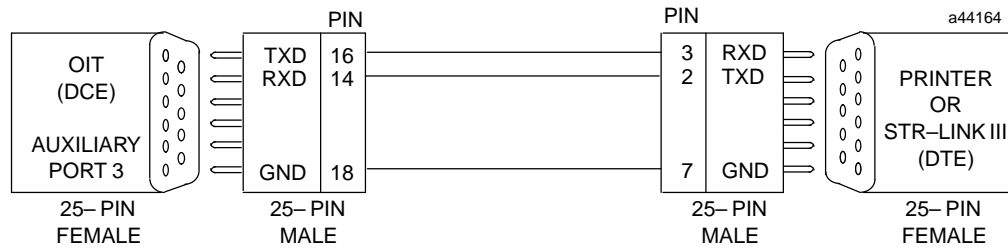

Figure 3-10. RS-232C Point-to-Point Communication (OIT Secondary Port Alternate Connection to Printer or STR-LINK III)

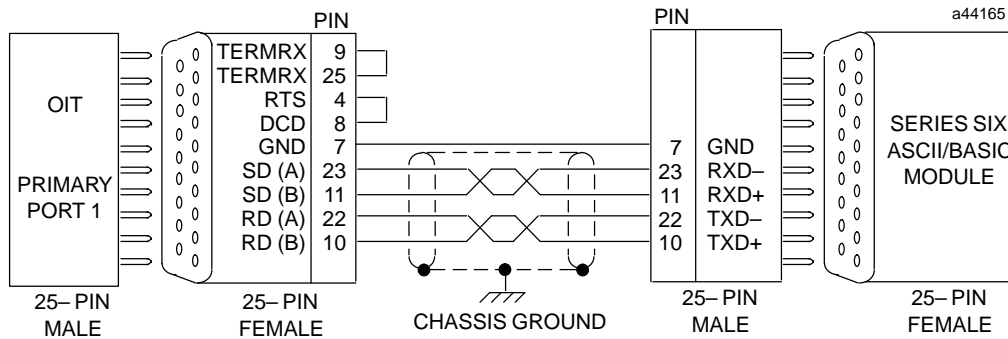

Figure 3-11. RS-422 Point-to-Point Communication (OIT Primary Port to Series Six ASCII/BASIC Module)

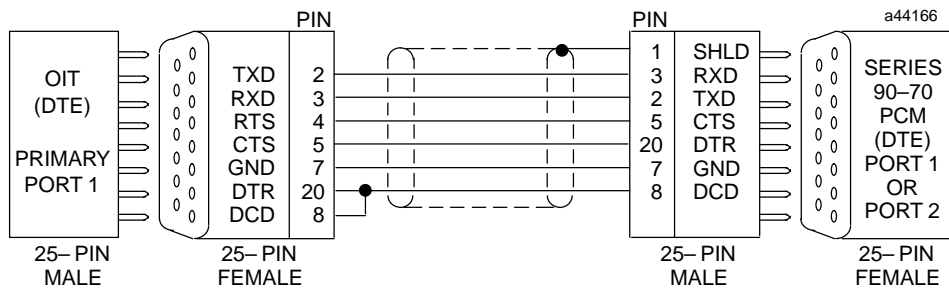

Figure 3-12. RS-232 Point-to-Point Communication with Handshaking (OIT Primary Port to Series 90-70 PCM Module Port 1 or Port 2)

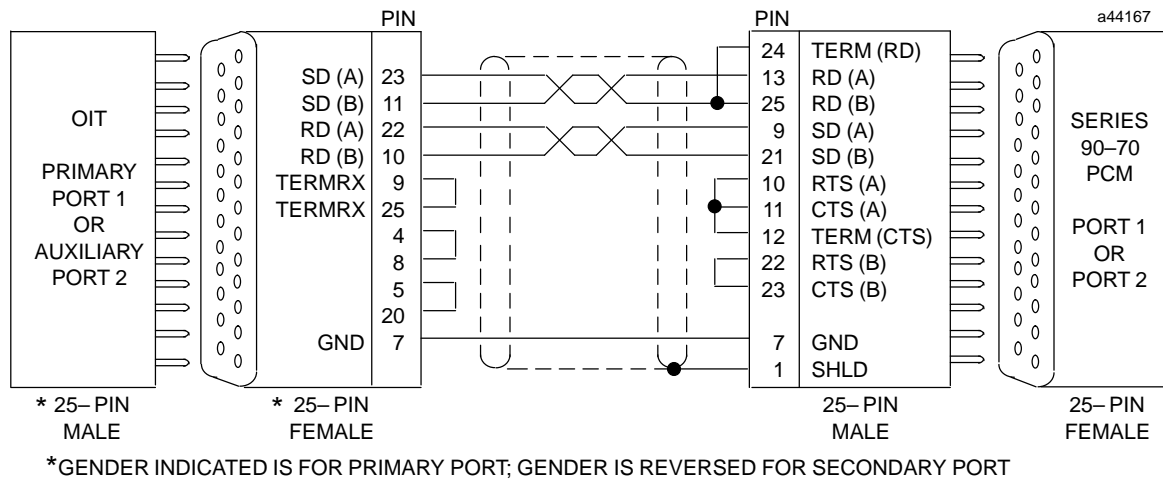

Figure 3-13. RS-422 Point-to-Point Communication with Handshaking (OIT Primary Port or Secondary Port to Series 90-70 PCM Module Port 1 or Port 2)

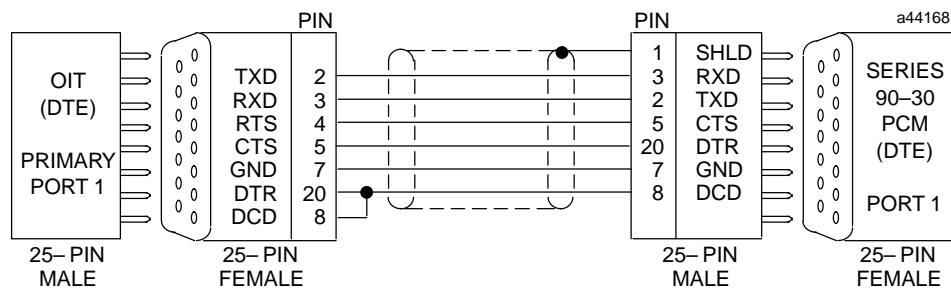

Figure 3-14. RS-232 Point-to-Point Communication with Handshaking (OIT Primary Port to Series 90-30 PCM Module Port 1)

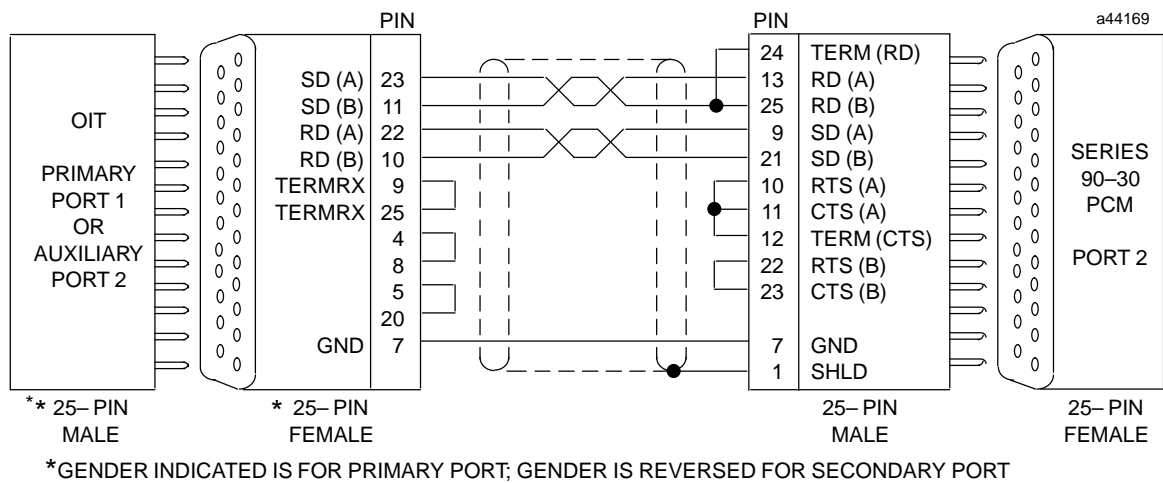

Figure 3-15. RS-422 Point-to-Point Communication (OIT Primary Port or Secondary Port to Series 90-30 PCM Module Port 2)

## Multidrop Operations

The OIT is designed with RS-422 interfaces so that a number of units can be linked on a multidrop line. Multidrop protocol messages are completely interrupt driven, reducing the delay between the end of the message and the time that the OIT places its transmitter in a high impedance state. This permits a host to poll a number of slaves with minimum delay between polls.

### Configuring the OIT

Once you select *Multidrop* operation in the Configuration Menu, the system requires you to specify an address between 00 and 99. Although addresses may fall between 00 and 99, you are limited to a maximum of 16 slaves, depending on cable lengths, connection quality, and the communications baud rate. The 00 to 99 address identifies one of the 16 OITs for later operations. On power up, or when first selecting multidrop operation, the OIT automatically disables itself from receiving or transmitting data.

When you select *Multidrop* operation in the Configuration Menu, the OIT automatically selects *Software* handshaking and *Echo* operation.

- *Software* handshaking uses the XON (or DC1) and XOFF (or DC3) codes to prevent transmission overruns. RS-422 multidrop operation requires this method since it does not offer RTS and CTS signals. Also, RS-422 multidrop operation does not allow the “message data” to use the DC1 or DC3 codes.
- *Echo* operation displays operator keystrokes on the screen immediately, even though the host has not yet received the data.
- For special requirements, or when the polling of OITs takes place at high speeds, *No Echo* operation can be used. The host, however, must select *No Echo* mode by sending the OIT the appropriate escape sequence.

You, the user, can select *hardware* handshaking. With the multidrop protocol, hardware handshaking operates the same as no handshaking, allowing you to use the protocol itself as a form of handshaking:

- When the system polls a slave, the slave transmitter is enabled from the time the system receives the address until the system receives the end of message code. If the system receives the end of message code while the slave is still transmitting, the system turns the slave transmitter off and the slave saves the remaining data in the output buffer. When the slave receives the next polling message, it continues the transmission.
- In a single poll, the slave can transmit the same approximate number of characters as the number of character frame times between the slave address and the end of message code. At a minimum, this time is the same as the number of characters transmitted as data from the host to the slave. The host may also designate a delay between sending the slave address and the end of message code.

After configuring the OIT with the communications specifications for your application, enter into *ONLINE* mode unless you plan on running an OptiBASIC program.

### Wiring for RS-422 Communications

You should make sure that extra signals from the host equipment are not connected to RS-422 pins during RS-232C operation and, similarly, that extra signals from the host equipment are not connected to RS-232C pins during RS-422 operation.

When an OIT has not been selected during multidrop operation, its transmit signals are put in a high-impedance state. The host computer may require you to connect pull-up and pull-down resistors to its receive signals to avoid spurious data when no OIT has been selected for operation.

Support of RS-422 signals by a host device does not guarantee a multidrop configuration. The host must be able to drive the receiving circuitry of all connected devices. Moreover, to effectively support multiple OITs, the host software must be capable of polling and keeping track of communications with all the OITs in an orderly manner, and usually on a real-time basis. Consult the supplier of your host device for additional information.

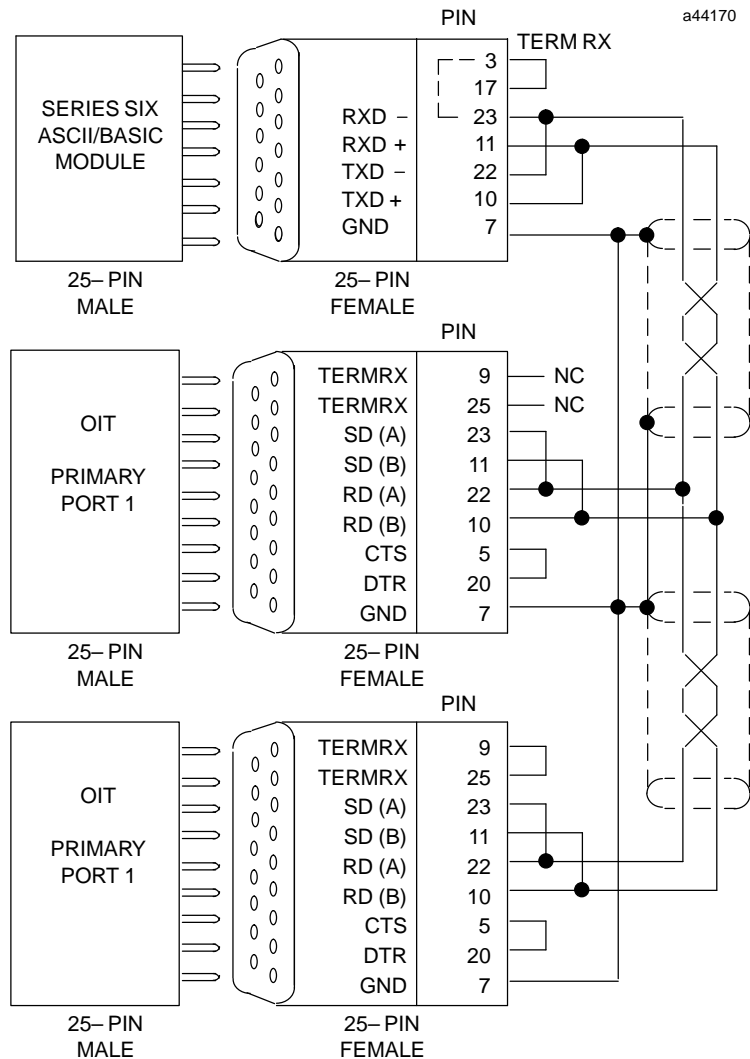
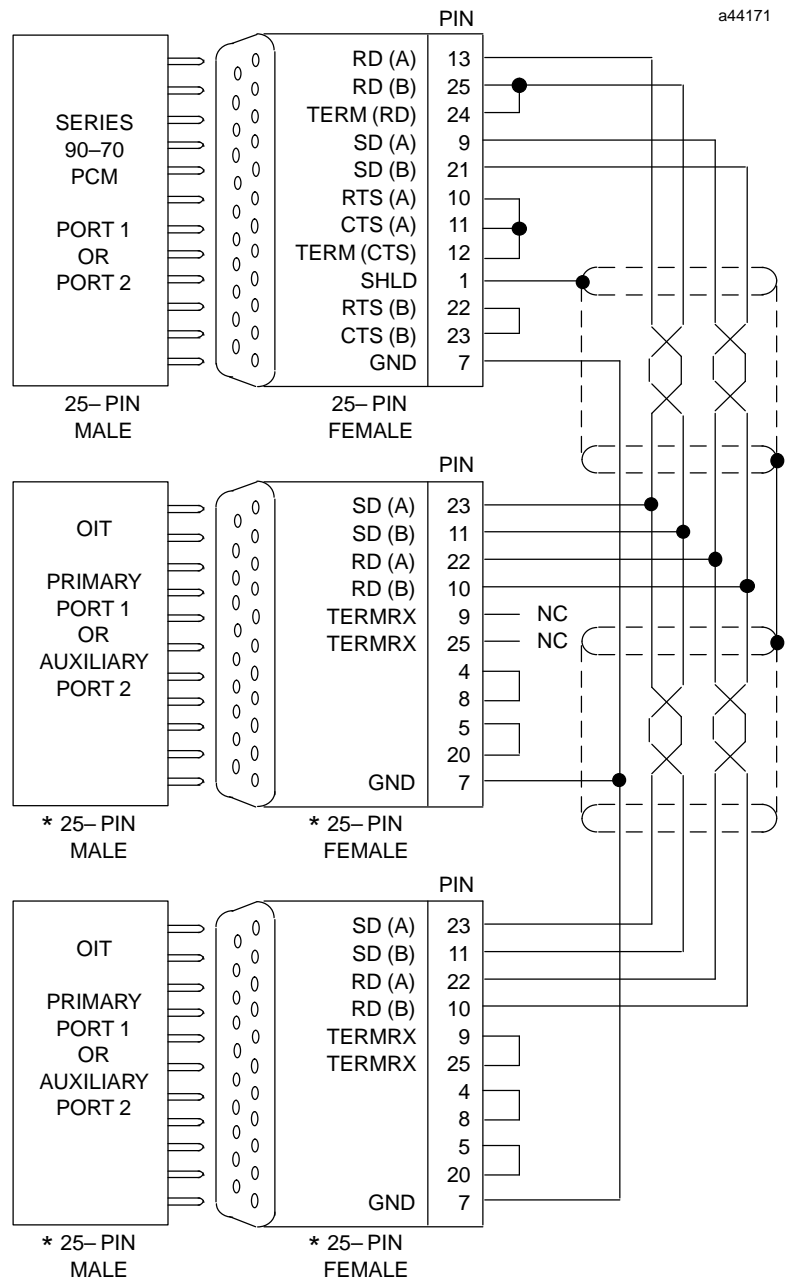
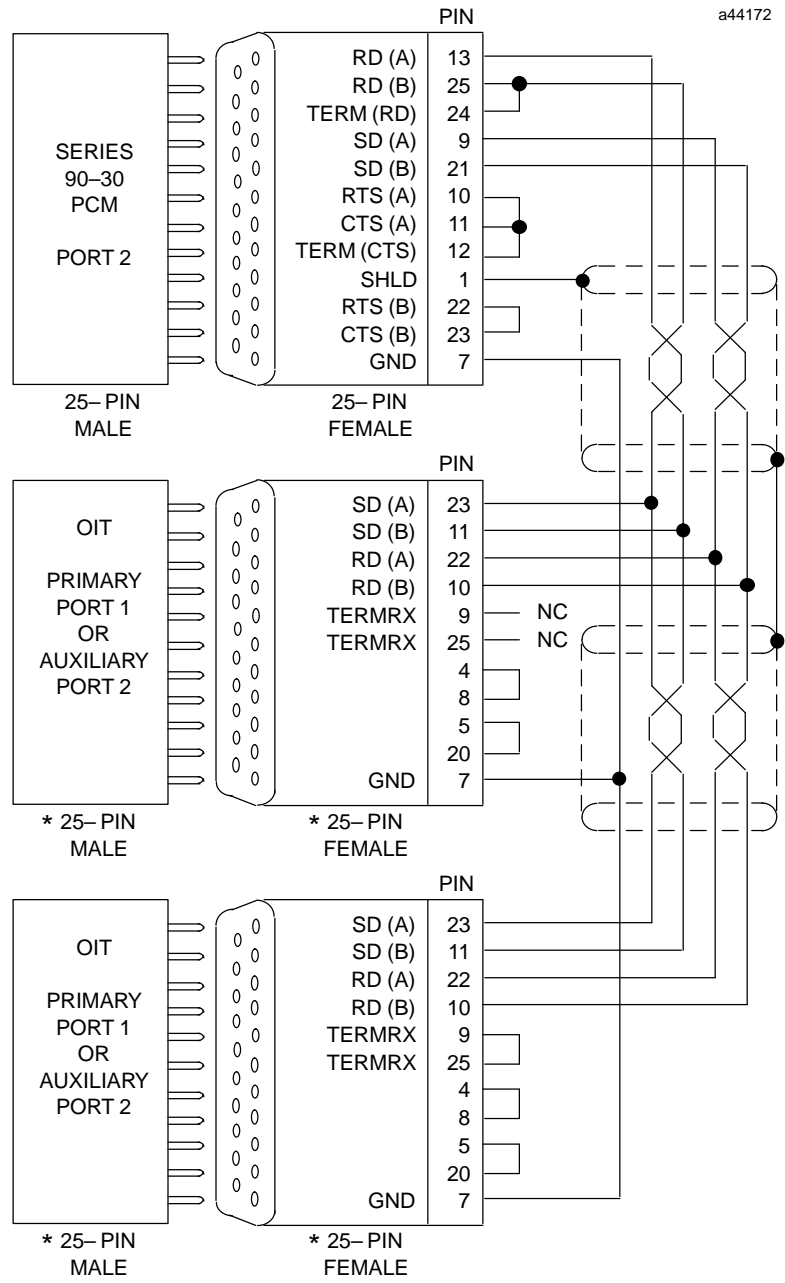

Figure 3-16. RS-422 Multidrop 2-Wire (OIT Primary Port to Series Six ASCII/BASIC Module)



\* GENDER INDICATED IS FOR PRIMARY PORT; GENDER IS REVERSED FOR SECONDARY PORT.

**Figure 3-17. RS-422 Multidrop 4-Wire (OIT Primary Port to Series 90-70 PCM Module Port 1 or Port 2)**



\* GENDER INDICATED IS FOR PRIMARY PORT; GENDER IS REVERSED FOR SECONDARY PORT.

Figure 3-18. RS-422 Multidrop 4-Wire (OIT Primary Port or Secondary Port to Series 90-30 PCM Module Port 2)

## How Multidrop Operation Works

A typical sequence for a host device to poll a series of RS-422 slaves appears below:

1. To enable your OIT for both transmission and reception, the host sends [Ctrl]-P (Data Link Escape, or ASCII code 16) followed by the two digit address for the desired OIT. The address appears in standard ASCII format and uses two digits; for example, the system addresses OIT 5 as 05. For example, the host transmits the following ASCII codes:

```
16 48 49
```

ASCII code 16 is [Ctrl]-P. ASCII code 48 is 0. ASCII code 49 is 1. This sequence initiates communications with slave 1.

2. The system transmits the “message string” to the host. The system displays keyboard entries on the screen and stores them for subsequent transmission. The system stores a maximum of 256 characters before it loses data. Once you select an OIT, any keyboard entries being stored are automatically transmitted as the message string, and normal operation (as if point-to-point connection were in effect) takes place between the host and the OIT.
3. The host transmits a series of escape sequences to the slave.
4. The host can subsequently disable a OIT by sending [Ctrl]-W (End of Transmission Block, or ASCII code 23). For example, two-way communication continues until the hosts transmits the following ASCII code:

```
23
```

ASCII code 23 is [Ctrl]-W. This sequence ends communications with slave 1.

5. Continuing, the host transmits the following ASCII codes:

```
16 48 50
```

ASCII code 16 is [Ctrl]-P. ASCII code 48 is 0. ASCII code 50 is 2. This sequence initiates communications with slave 2.

And so on, until all of the multidrop devices have been polled.

The system automatically enables an OIT with the address 00 to receive data addressed to any OIT, but the OIT is not enabled to transmit unless the host specifically transmits the 00 address. If the host transmits the address 00, all OITs are enabled to receive data, but only OIT 00 (if it exists) is enabled to transmit data.

Multiple OITs may use the same address, but only one OIT with the given address may be electrically connected to transmit data.

Similarly, more than one address may be enabled at the same time. Simply transmit the enabling code for an address (without an intervening [Ctrl]-W code), followed by the message string for the address; then transmit the enabling code for an address, followed by a message string, and so on. Again, however, only one OIT may be electrically connected for transmitting data.

The OIT uses the control codes for enabling and disabling ports in the same sequence as it does for all other commands and characters. Therefore, the system processes all commands and characters it receives before it executes a command to relinquish the multidrop link. Also, the host command to establish a new connection cannot be sent until the OIT relinquishes the previous connection. Therefore, you may be required to specify a delay between turning off one OIT and turning on another to prevent more than one OIT from operating simultaneously. The OIT holds up to 255 characters in its buffer and generally processes over 1000 characters per second; therefore, a 1/8th second delay (0.125 second) should be adequate unless you send a complex escape sequence, such as a screen display.

## Installing Memory and Logic Board Jumpers

The OIT is designed for flexible memory management and usage. A limited number of jumpers, used for functions such as manufacturing tests and specifying CRT type, appear on the board.

### Memory

The standard OIT comes with 64K bytes of battery-backed CMOS RAM, expandable to 188K bytes of battery-backed CMOS RAM. The OIT-OptiBASIC comes with 188K which is the maximum amount. The total memory is 192K but 4K is reserved for system use.) The OIT uses the following memory banks.

Bank	Chip Location	Purpose
Bank 0	U44	Shipped with 32K of memory
Bank 1	U45	Empty, available for 32K of memory
Bank 2	U57	Empty, available for 32K of memory
Bank 3	U58	Empty, available for 32K of memory
Bank 4	U56	Empty, available for 32K of memory
Bank 5	U55	Shipped with 32K of memory

The following RAM chip part numbers are recommended for replacing or for adding memory.

- NEC D43256C-12L
- Mitsubishi M5M5256P-12L
- Sony CXK58256P-12L

The diagram provides a schematic layout for memory and jumper locations. Due to changes that may be made to the logic boards, the diagram may differ slightly from the logic board actually installed.

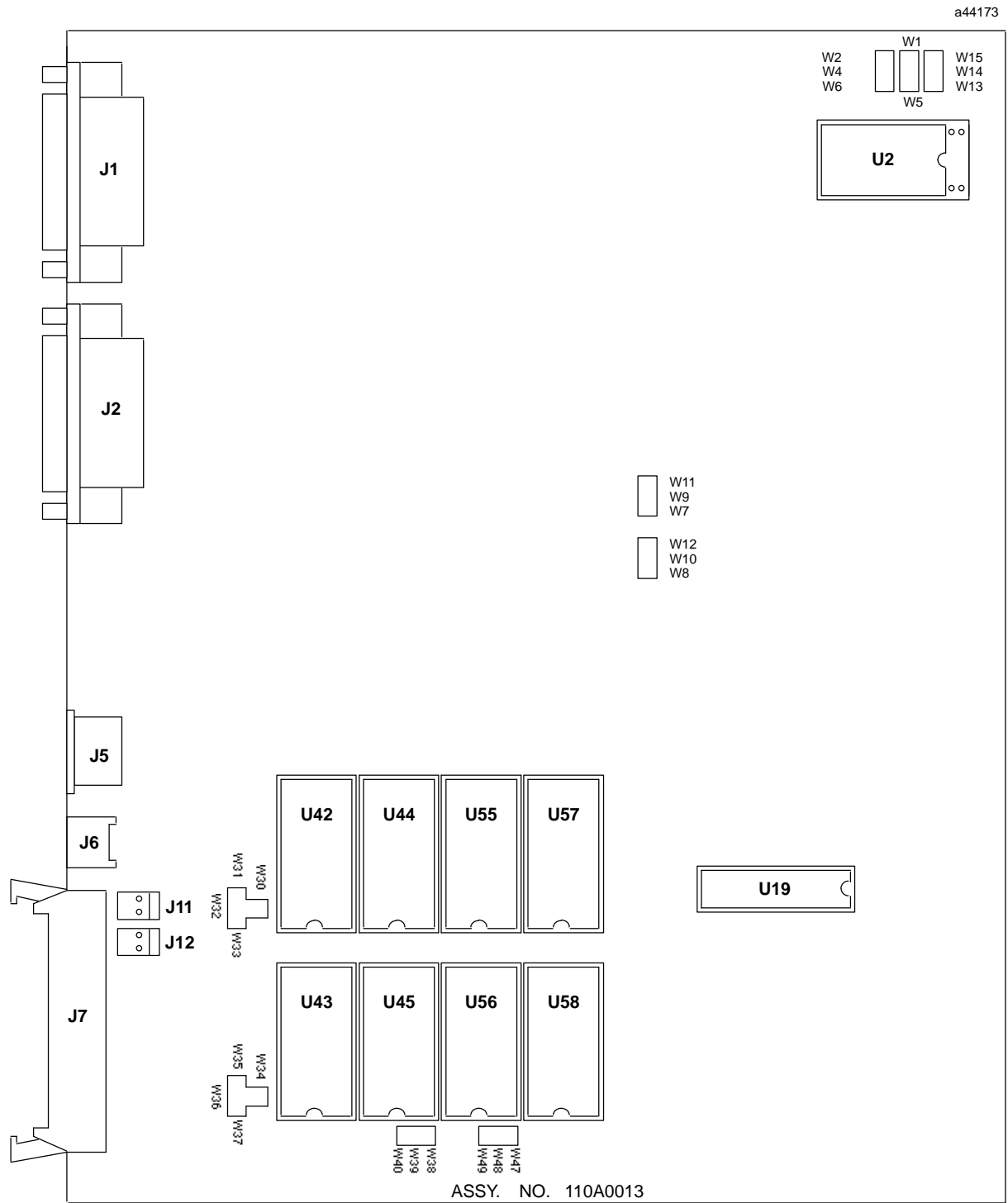

Figure 3-19. Logic Board-Memory Chip Location

To change the type or amount of memory available, use the following procedure:

1. Unplug the OIT from the main power source.

### Warning

**High voltages are present in the OIT while power is connected, even if the OIT is turned off.**

2. Remove the screws holding the bottom panel of the OIT chassis. At this time, only a few modular wiring harnesses connect the bottom panel to the top section.
3. Unplug the wiring harnesses. Note the location and orientation of the harnesses for reinstallation.
4. Disconnect the battery before adding or removing memory.

### Warning

**Adding or removing memory chips while the battery is still connected can damage the chip.**

5. Locate the vacant memory sockets (U45, U57, and U58) on the main circuit board.
6. Refer to information given with the memory chips for proper installation. Insert each memory chip so that the notch (or dot) at one end of the chip corresponds to the notch at one end of the memory socket. (All of the memory chips on the board line up in the same direction.) After verifying that the chip is installed with the proper orientation, verify that all pins of the memory chip are properly inserted in the socket.

### Caution

**Static electricity damages the logic board and the memory chips. Always ground yourself before you touch the logic board. Keep uninstalled memory chips in their packaging until ready for use. Damage to the logic board or the memory chips due to improper handling or installation is not covered by the warranty.**

7. Verify the jumpers that control battery backup to each memory location. Refer to information given with the memory chips for proper jumper installation. CMOS memory uses battery backup to retain screens and data. EEPROM memory must not use battery backup; this avoids draining the battery and allows the battery to be used for functions that require it.
8. Reconnect the cable harnesses to the circuit board and remount the bottom panel of the chassis.

## Jumpers

All jumpers are configured for proper operation when shipped. You are responsible for verifying the jumper configuration when you change the configuration of the OIT, or when you install a new logic board.

The following table shows the jumper configuration and descriptions for the jumper locations on the logic board.

Jumper Pin Number	Configuration	Jumper Function
W1 - W3	Jumper	D4 = Blue (gray scale bit 0)
W4 - W6	Jumper	Underlinedisabled
W7 - W9	Jumper	Horizontal synch signal active low
W9 - W11	None	Horizontal synch signal active high
W8 - W10	Jumper	Vertical synch signal active low
W10 - W12	None	Vertical synch signal active high
W31 - W32	Jumper	Selects EPROMs
W35 - W36	Jumper	Selects EPROMs
W48 - W49	Jumper	Not used

## CRT Adjustment

On both monochrome and color OITs, you can find an external knob below the OIT chassis for adjusting brightness. The following figures show some of the other available adjustment controls for the CRT.

**Warning**

**Due to the dangerous voltages present within the OIT, adjustment of these controls should only be performed by qualified personnel.**

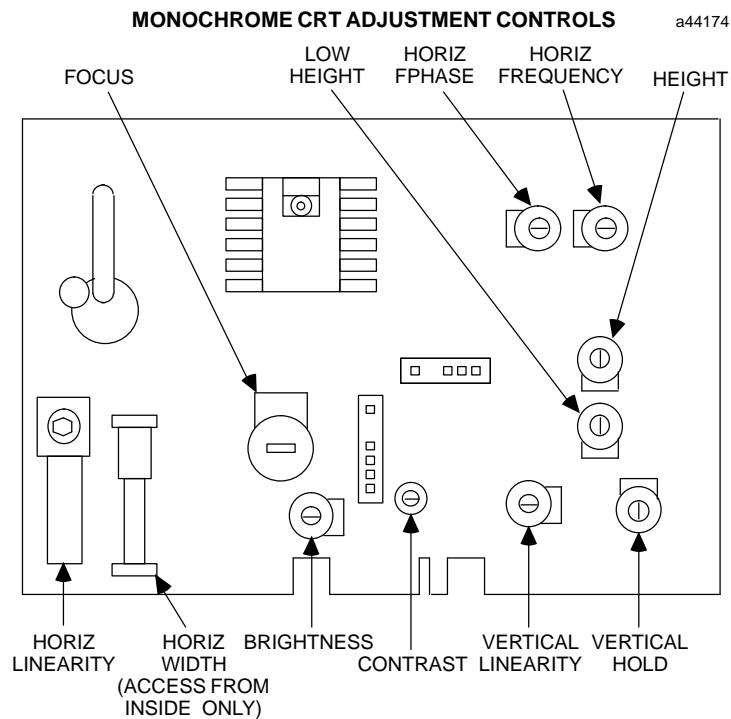

Figure 3-20. Monochrome CRT Adjustment Controls

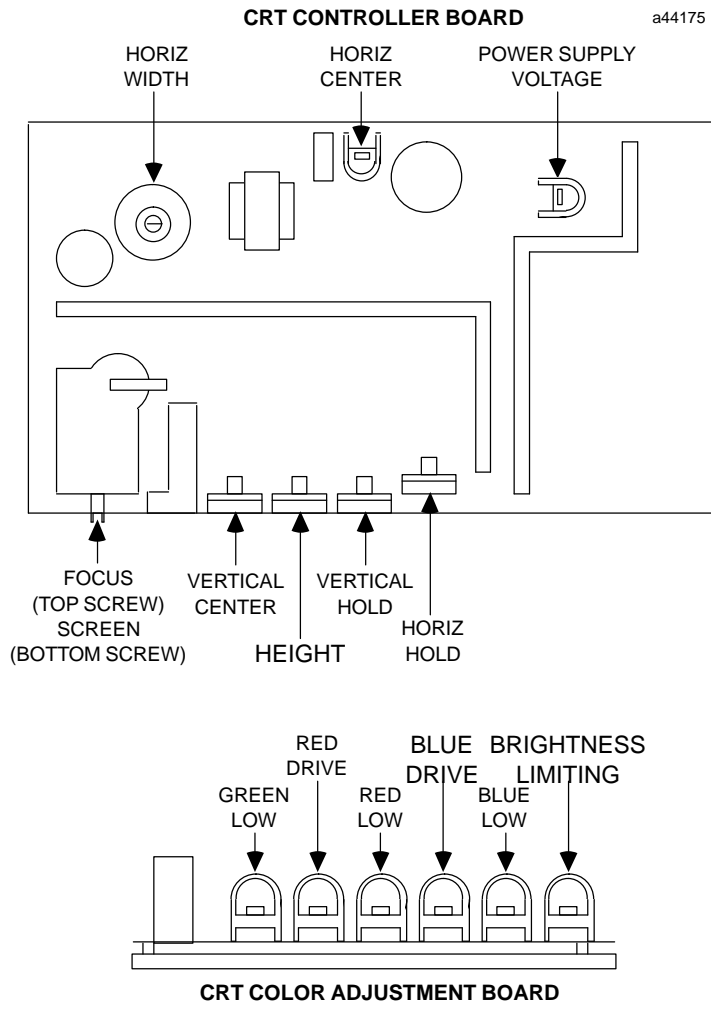

Figure 3-21. Color CRT Adjustment Controls

# Chapter 4

## Operation

This chapter outlines the system available for entering the OptiSCREEN editors, configuring the system, and transferring screens and files to and from a host with the menu-driven system. The menu-driven system also gives directory listings of screens and files, and displays variables and their values. With a full-travel keyboard attached to the OIT, these capabilities increase the ease-of-use and speed of development for applications by providing the following features:

- The system displays valid function keys in the function bar at the bottom of the screen. You press one of the [F1] through [F10] function keys to make your selection. After you press the key, the system displays another menu, offers a list of screens or files to choose from, or executes an operation:
  - When the system displays another menu, you press another function key to make another selection.
  - When the system offers a list of screens or files, you use the cursor control keys (the “arrow keys” labeled [Up], [Down], [Left], and [Right] on the keypad) to highlight a screen or file and then press the appropriate function key to select the operation you want to perform.
  - When the system executes an operation, it completes the process and then returns you to the appropriate menu or screen so that you can continue working.
- To move between the choices displayed on the main function bar, you must always return to the main function bar before selecting another choice. The following diagram shows the relationship of the various menu choices:

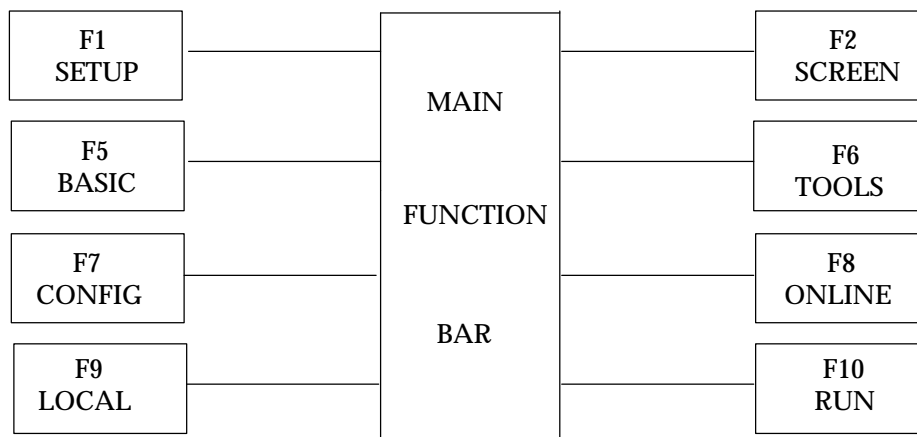

- You can return to the main function bar from almost any point in the system by pressing the [Ctrl]-[1] combination of keys. Also, most menus allow you to “back out” of the menu by pressing one or more function keys. In many cases, you can simply press the [F1] function key to return to the main function bar.

- On color models function keys that appear in red in the function bar at the bottom of the screen represent the most powerful and important choices on the menu. Functions keys that appear in blue represent helpful and convenience-oriented choices on the menu. For example, the [F1] MAIN function key appears in red in the function bar at the bottom of the screen when you can press it to return to the main function bar.
- The menu-driven system makes it easy for you to move between different kinds of screens and files. The red [F1] MAIN menu item usually returns you to the main function bar. From that menu you can select a variety of operations. When you return to the menu item that you were working with before you entered the main menu, the screen or the file that you were working with automatically appears with the cursor exactly where you left it.
- In general, the system makes the entry of all screen and file names as simple as possible. If the name of the screen or file does not appear in a selection screen (for example, when you create a file with a new name), you must enter the name yourself. Uppercase and lowercase letters do not matter in this case. For editing convenience, you can use the [Backspace] key to erase the last letter or letters in the name of an existing file.
- In most cases the same item falls in the same place on different menus. For example, the MAIN menu item appears with the [F1] function key in most menus. The SAVE menu item (if it exists) appears with the [F5] function key. This helps you remember the operation of the various function keys and makes the firmware easier to use.
- If you do not make a valid menu item selection or make a valid entry for a prompt, the system does not make any changes by default.

This chapter describes the GE Fanuc Automation family of OITs. Some capabilities, such as the color CRT, may or may not be available on your OIT.

## Turning the OIT On

The power on/off switch is located at the rear of the OIT. Whenever you turn the unit on, allow the CRT about 30 seconds to warm up. The OIT first performs self-diagnostics. Tests include verification that all system memory is working, that the various peripheral circuits function, and that the battery is working properly. If all tests pass, the OIT automatically enters the Main Menu or executes the application previously specified to run at power-up. If any test or tests fail, the system displays a message indicating the type of failure or failures.

The following conditions cause the *BATTERY PROBLEMS* message to appear:

- If the jumpers for the installed memory are improperly configured, you must correct them. Check the jumper configuration tables for the installed memory described in Chapter 3.
- If the battery voltage falls below a certain level, you must replace the battery. The first time this happens, a limited amount of battery life may remain. To keep from losing the memory, do not remove the old battery assembly until you connect the new assembly.

If you have not installed the battery, the OIT passes the battery test, but causes the checksum error message to be displayed.

If all the tests pass, the OIT automatically enters the Main Menu or executes the application previously specified to run at power-up. If the above test fails, you may press any key to continue to the Main Menu or execute the application specified to run at power-up.

## The Main Menu - The Main Function Bar

Within the menu system, the main function menu and main function bar appear first; for example:

```

      GE Fanuc Industrial Workstation

F1 SETUP - Setup Workstation for          F6 TOOLS - Transfer files to/from
power-up operation,                      cartridge or host,
run demo program                          maintain internal files

F2 SCREEN- Create or edit                F7 CONFIG- Configure serial
graphic screen files                      ports, execute
                                           diagnostic tests

F3                                         F8 ONLINE- Enter Online
                                           Terminal Mode

F4                                         F9 LOCAL - Emter Local
                                           Terminal Mode

F5 BASIC - Edit OptiBASIC file           F10 RUN  - Run program selected
                                           on Setup Menu

-----
                                MAIN FUNCTIONS
SETUP  SCREEN          BASIC  TOOLS  CONFIG  ONLINE  LOCAL  RUN
F1     F2     F3     F4     F5     F6     F7     F8     F9     F10
Power-up Status:  DISPLAY MAIN MENU
  
```

The menu choices, with a summary of what each does, appear below:

**[F1] SETUP** - Specifies the status or the OptiSCREEN application that the OIT runs when you power-up the OIT or press the [F10] RUN key while using the system.

**[F2] SCREEN** - Enters the OptiSCREEN screen editor so that you can create or edit a screen.

**[F5] BASIC** - (For OIT-OptiBASIC models only.) Enters the OptiBASIC file editor so that you can create or edit an OptiBASIC program file.

**[F6] TOOLS** - Enters the utility menu so that you can transfer screens, files, and data to and from an IBM-compatible host. This item also performs housekeeping operations on internal files.

**[F7] CONFIG** - Specifies the serial communications parameters, ports, and diagnostic tests for the OIT.

**[F8] ONLINE** - Specifies that the system enters the Online mode for communication.

**[F9] LOCAL** - Specifies that the system enters the Local mode for testing and operation.

**[F10] RUN** - Executes the application named on the power-up status line at the bottom of the screen. Specify the application with the [F1] SETUP menu item from the main menu.

Each of these menu items leads you to another menu or set of selections. The menus and selections appear below.

## The SETUP Menu - [F1] from the Main Function Bar

This menu specifies the application or status to be executed or displayed when you power-up the system or when you press the [F10] RUN key from within the system. This menu displays the current setting of the SETUP item at the top of the menu and in the power-up status line at the bottom of the screen; for example:

```

SETUP

Workstation Power-up Status:

      MAIN MENU

1 - Display main menu
2 - Enter ONLINE operation
3 - Enter LOCAL operation
4 - Run MYSTART application
5 - Run application
6 - Run application

-----
MAIN          F1          F2          F3          F4          F5          F6          F7          F8          F9          RUN
Power-up Status: MAIN MENU          F10

```

The menu choices, with a summary of what each does, appear below:

**[F1] MAIN** - Returns to the main function bar so that you can make another menu selection.

**[F10] RUN** - Runs the application named on the power-up status line at the bottom of the screen. You use the 1 through 6 numeric keys to specify the application that appears in the status line.

If you press the 1 through 6 numeric keys on the keyboard or on the keypad, you specify the following functions to occur on power-up.

- 1** - **Display main menu** Specifies that the system displays the main menu when you power-up the system or press the [F10] RUN key from many of the menus. A complete description of the main menu appears above.
- 2** - **Enter ONLINE operation** Specifies that the system enters the Online mode for communication with a host when you power-up the system or press the [F10] RUN key from many of the menus.
- 3** - **Enter LOCAL operation** Specifies that the system enters the Local mode when you power-up the system or press the [F10] RUN key from many of the menus.
- 4-6** - **Run application** Specifies that the system executes an OptiSCREEN application when you power-up the system or press the [F10] RUN key from many of the menus. After you press numeric key 4, 5 or 6, the system prompts you to "Enter or change an application name." The name of the application appears in the menu after you specify it; for example, *MYSTART* in the menu shown above names an OptiSCREEN file that you specified at the prompt.

The system offers three user-definable applications (used by the numeric keys 4, 5, and 6) to make it easier to switch among different applications. For example, you may want to make numeric key 4 the STARTUP OptiSCREEN program, numeric key 5 the CHECKUP OptiSCREEN program, and numeric key 6 the MYRUN OptiSCREEN program. Then, if you want the system to execute CHECKUP, instead of STARTUP, the next time you power-up or press the [F10] RUN key from another menu, you can simply press numeric key 5 from this menu to specify the different program.

## The Screen Menu - [F2] from the Main Function Bar

This menu enters the OptiSCREEN screen file editor so that you can create or edit a screen. The system displays a directory of OptiSCREEN files and prompts you to “Select file” from the list; for example:

```

SCREEN FILE EDITOR - DIRECTORY

FILE1          FILE2          QUARTZ          FILE4
FILE5          OPAL            FILE7           FLINT
FILE9          FILE10         GARNET         FILE12
FILE13         FILE14         FILE15         FILE16
FILE17

SELECT FILE:  QUARTZ
-----
MAIN   SYNTAX  EDIT   SHOW   RENAME  COPY   DELETE  RUN
F1     F2      F3     F4     F5      F6     F7      F8      F9      F10
Power-up Status:  DISPLAY MAIN MENU

```

Use the cursor control keys to move through the OptiSCREEN names and highlight the screen you want to work with before you press one of the function keys described below. To create a new file, use the [Backspace] key to delete one or more characters of the current screen name and enter the name of the new file in response to the “Select file” prompt. The file that you select or enter is called the “current file.”

The menu choices, with a summary of what each does, appear below:

**[F1] MAIN** - Returns you to the main function bar so that you can make another menu selection. When you return to this SCREEN menu, the system recalls the screen on which you were working when you pressed the [F1] MAIN menu selection. If you were in edit mode prior to pressing the [F1] MAIN menu selection, the system returns you to edit mode.

**[F2] SYNTAX** - Displays, in alphabetic order, the command and parameter syntax for all of the OptiSCREEN statements. Use the [Up] and [Down] cursor control keys to move through the list of commands. Press one of the following function keys to exit the syntax list:

[F1] MAIN - Returns to the main function bar so that you can make another menu selection.

[F3] EDIT - Returns to the current OptiSCREEN screen file for further editing of the file.

[F10] DIR - Returns to the OptiSCREEN screen file directory so that you can create or select another screen.

**[F3] EDIT** - Places you in the OptiSCREEN EDIT menu so that you can edit the current screen file; for example

```

'Text for "Blower ON"

MOVE TO 10, 10
DOUBLE WIDE
DISPLAY "Blower ON"
MOVE TO 11, 32
BOX 3 x 4

-----
MAIN   STEP   SHOW  SAVE  ABORT  DELETE  INSERT  DIR
F1     F2      F3    F4    F5     F6     F7      F8      F9      F10
EDITING: MYFILE2

```

The menu choices, with a summary of what each does, appear below. Each of the choices operates on the current screen file (named at the bottom of the screen) which you selected from the directory or entered in response to the “Select file” prompt:

[F1] MAIN - Displays the main function bar so that you can make another menu selection. When you return to the SCREEN menu, the system recalls the screen on which you were working when you pressed the [F1] MAIN menu selection.

[F2] STEP - Graphically executes the commands in the current screen file from the top of the file to the line where your cursor currently rests. By pressing the [Down] arrow key, the system graphically executes the next line in the file. By repeatedly pressing the [Down] arrow key, you can work through the file line-by-line, command-by-command. After viewing the results of the screen file, press any function key to return to the screen file for further editing.

[F4] SHOW - Displays the entire graphic output of the current screen file. After viewing the results of the screen file, press any function key to return to the screen file for further editing.

[F5] SAVE - Saves the current screen file. After informing you that the file has been saved, the [F5] SAVE item allows you to continue editing the current screen file. Be sure to use the [F5] SAVE key and save the current screen file before exiting the file.

[F7] ABORT - Exits the current version of the screen file without saving any changes that you made to it and returns you to the last saved version of the current screen file for further editing.

[F8] DELETE - Deletes the current line. The [Ctrl]-[Del] key combination also deletes the current line.

[F9] INSERT - Inserts a line at the current location. The [Ctrl]-[Ins] key combination also inserts a line at the current location.

[F10] DIR - Returns you to the OptiSCREEN screen file directory so that you can create or edit a screen.

**[F4] SHOW** - Displays the entire graphic output of the current screen file. Press any function key to exit the display and return to the OptiSCREEN screen file directory to select or create a new screen file.

**[F6] RENAME** - Prompts you to enter the new name for the current screen file.

**[F7] COPY** - Prompts you to enter the name of the file to which you want to copy the current screen file. If it does not already exist, the system automatically creates the file that you name for the copy.

**[F8] DELETE** - Deletes the current screen file. The system queries you to make sure that you have selected the appropriate file before deleting it.

**[F10] RUN** - Runs the application named on the power-up status line at the bottom of the screen. Specify the application with the [F1] SETUP menu from the main menu.

## The BASIC Menu - [F5] from the Main Function Bar

This menu enters the OptiBASIC file editor so that you can create or edit an OptiBASIC file. OptiBASIC is available only on the OIT with OptiBASIC. The system displays a directory of OptiBASIC files and prompts you to "Select File" from the list; for example:

```

SCREEN FILE EDITOR - DIRECTORY

FILE1      FILE2      QUARTZ      FILE4
FILE5      OPAL       FILE7       FLINT
FILE9      FILE10     GARNET     FILE12
FILE13     FILE14     FILE15     FILE16
FILE17

SELECT FILE:  QUARTZ

-----
MAIN          EDIT          RENAME    COPY    DELETE    RUN
F1           F2           F3         F4      F5        F6      F7      F8      F9      F10
Power-up Status:  DISPLAY MAIN MENU

```

Use the cursor control keys to move through the OptiBASIC file names and highlight the file you want to work with before you press one of the function keys described below. If no files are listed, enter the name of the first file you want to create. To create a new file, use the [Backspace] key to delete one or more characters of the current screen name and enter the name of the new file in response to the "Select file" prompt.

**[F1] MAIN** - Returns to the main function bar so that you can make another menu selection. When you return to this BASIC menu, the menu system recalls the screen on which you were working when you pressed the [F1] MAIN menu selection.

**[F3] EDIT** - Places you in the OptiBASIC EDIT menu so that you can edit the current OptiBASIC program file; for example:

```

10 'This is a simple OptiBASIC program
20 '
30 CLS '                Clear the screen
40 '
50 PRINT DFILE (TITLE1) ' Display Title 1
60 PRINT DFILE (TITLE2) ' Display Title 2
70 '
80 PRINT DFILE (DEMOFILE) ' Display body of screen
90 '
100 END

-----
MAIN          F10
F1           F2           F3           F4           F5           F6           F7           F8           F9           DIR
EDITING:  SIMPFILE

```

The menu choices, with a summary of what each does, are described below. Each of the choices operates on the current OptiBASIC file which you selected from the directory or entered in response to the "Select file" prompt:

[F1] MAIN - Saves the current OptiBASIC file and returns to the main function bar so that you can make another menu selection. When you return to the BASIC menu, the system returns to edit mode and recalls the screen on which you were working when you pressed the [F1] MAIN menu selection.

[F10] DIR - Saves the current OptiBASIC file and returns to the OptiBASIC file directory so that you can create or edit a file.

Type the *RUN* command on any unnumbered line to execute the current program.

While running an OptiBASIC program, you can use the [Ctrl]-C combination of keys to terminate the program. Then press the [Ctrl]-1 combination of keys to return to edit mode, or enter the *SYS* command and press the [Enter] key to return to the Main Menu.

[F6] RENAME - Prompts you to enter the new name for the current OptiBASIC file.

[F7] COPY - Prompts you to enter the name of the OptiBASIC file to which you want to copy the current file. If it does not already exist, the system automatically creates the file that you name for the copy.

[F8] DELETE - Deletes the current OptiBASIC file. The system queries you to make sure that you have chosen the correct file before deleting it.

[F10] RUN - Runs the application named on the power-up status line at the bottom of the screen. Specify the application with the [F1] SETUP menu from the main menu.

## The TOOLS Menu - [F6] from the Main Function Bar

This menu enters the TOOLS utility menu so that you can transfer screens, files, and data to and from an IBM-compatible host. After you select this item, the system displays the following menu. The files shown below are only examples and do not exist:

TOOLS									
FILENAME	TYPE	SIZE	TITLE	VALUE	LOCATION				
1 QUARTZ	SCREEN	12	PROGRAM ONE		INT 1:2026				
2 GYPSUM	SCREEN	130	PROGRAM TWO		INT 1:1036				
3 SHALE	SCREEN	215	PROGRAM THREE		INT 2:50D2				
4 BAUXITE	SCREEN	28	PROGRAM FOUR		INT 1:0300				
5 GARNET	SCREEN	76	PROGRAM FIVE		EXT 8:1000				
-----									
MAIN	TYPES	MARK	MK ALL	CART	RENAME	COPY	DELETE	HOST	RUN
F1	F2	F3	F4	F5	F6	F7	F8	F9	F10
Power-up Status: DISPLAY MAIN MENU									

The menu choices, with a summary of what each does, appear below:

[F1] MAIN - Returns to the main function bar so that you can make another menu selection. When you return to the TOOLS menu, the system recalls the function as well as the screen or file on which you were working when you pressed the [F1] MAIN menu selection.

**[F2] TYPES** - Places you in the TOOLS TYPES menu so that you can select OptiSCREEN screen files, communications files, system files, variables, or all types of files and variables; for example:

TOOLS - TYPES									
FILENAME	TYPE	SIZE	TITLE	VALUE	LOCATION				
1	CHIPCONVEYER1	SCREEN	322	SCREEN ONE	INT 1:D5DB				
2	CHIPCONVEYER2	SCREEN	310	SCREEN TWO	INT 1:C22F				
3	CHIPCONVEYER3	SCREEN	215	SCREEN THREE	INT 2:BD33				
4	CHIPCONVEYER4	SCREEN	280	SCREEN FOUR	INT 1:C300				
MAIN	SCREEN		SYSTEM		VAR	ALL	ORG/BK		EXIT
F1	F2	F3	F4	F5	F6	F7	F8	F9	F10
Power-up Status: DISPLAY MAIN MENU									

The menu choices, with a summary of what each does, appear below:

**[F1] MAIN** - Returns to the main function bar so that you can make another menu selection. When you return to this TOOLS menu, the system recalls the file on which you were working when you pressed the **[F1] MAIN** menu selection.

**[F2] SCREEN** - Displays a list of OptiSCREEN screen files available on the system. After you select this item, the system highlights the **[F2] SCREEN** key in the function bar at the bottom of the screen.

**[F4] SYSTEM** - Displays a list of system files, such as configuration settings, available on the system. After you select this item, the system highlights the **[F4] SYSTEM** key in the function bar at the bottom of the screen.

**[F6] VAR** - Displays the variables and their current values available on the system. After you select this item, the system highlights the **[F6] VAR** key in the function bar at the bottom of the screen.

**[F7] ALL** - Displays a list of OptiSCREEN screen files, system files, and variables and their values. After you select this item, the system highlights the **[F7] ALL** key in the function bar at the bottom of the screen.

**[F8] ORG/BK** - Moves, or rotates, among original, backup, and both original and backup files for the currently selected *types* available on the system. Backup files use the BAK extension; the system stores them in the last available memory location, usually in the external memory cartridge.

After you select this item, the system highlights *ORG* when displaying original files only, *BK* when displaying backup files only, or *ORG/BK* when displaying both the original and backup files. This menu item works in conjunction with the **[F2] SCREEN** item through the **[F7] ALL** function.

**[F10] EXIT** - Returns you to the top level of the TOOLS menu.

**[F3] MARK** - Selects one or more screens or files that you want to rename, copy or delete. Use the cursor control keys to highlight a screen or file and then mark, or select, it by pressing the **[F3] MARK** key. You can then move to another screen or file for marking; or you can rename, copy, or delete the marked screens or files. If you previously selected one type of screen or file under the **[F2] TYPES** menu, then the **[F3] MARK** key only marks screens or files of the selected *type*. By selecting a screen or file

with the [F3] MARK function key a second time, you can unmark, or remove the selection, for a screen or file.

**[F4] MARK ALL** - Marks, or selects, all of the screens or files for renaming, copying, or deleting. If you previously selected one type of screen or file under the [F2] TYPES menu, then the [F4] MARK ALL key marks all of the selected *type*. By selecting a marked screen or file with the [F3] MARK function key, you can unmark, or remove the selection, for a single screen or file.

**[F5] CART** - Places you in the CARTRIDGE menu so that you can move files to and from the memory cartridge, or backup and restore files to and from the memory cartridge; for example:

**Note**

This function is not currently supported.

CART										
FILENAME	TYPE	SIZE	TITLE	VALUE	LOCATION					
1	CHIPCONVEYER1	SCREEN	322	SCREEN ONE	INT 1:D5DB					
2	CHIPCONVEYER2	SCREEN	310	SCREEN TWO	INT 1:C22F					
3	CHIPCONVEYER3	SCREEN	215	SCREEN THREE	INT 2:BD33					
4	CHIPCONVEYER4	SCREEN	280	SCREEN FOUR	INT 1:C300					
<hr/>										
MAIN	TYPES	MARK	MARK ALL	TO	FROM	BACKUP	RESTORE	HOST	EXIT	
F1	F2	F3	F4	F5	F6	F7	F8	F9	F10	

The menu choices, with a summary of what each does, appear below:

**[F1] MAIN** - Returns to the main function bar so that you can make another menu selection. When you return to this CART menu, the system recalls the file on which you were working when you pressed the [F1] MAIN menu selection.

**[F2] TYPES** - Places you in the CARTRIDGE item TYPES menu so that you can transfer a single type of screens, files, or variables to a cartridge. The CARTRIDGE item TYPES menu works like the TOOLS item TYPES menu described above.

**[F3] MARK** - Marks, or selects, one or more files that you want to move, backup, or restore to or from the memory cartridge. Use the cursor control keys to highlight a screen or file and then mark, or select, it by pressing the [F3] MARK key. You can then move to another screen or file for marking; or you can rename, copy, or delete the marked screens or files. If you previously selected one type of screen or file under the [F2] TYPES menu, then the [F3] MARK key only marks screens or files of the selected *type*. By selecting a screen or file with the [F3] MARK function key a second time, you can unmark, or remove the selection, for a screen or file.

**[F4] MARK ALL** - Marks, or selects, all of the screens and files for moving to or from, backing up, or restoring from the cartridge. If you previously selected one type of screen or file under the [F2] TYPES menu, then the [F4] MARK ALL key marks all of the selected *type*. By selecting a marked screen or file with the [F3] MARK function key, you can unmark, or remove the selection, for a single screen or file.

[F5] TO - Moves, or transfers, one or more marked files from internal memory to the memory cartridge. You cannot move system files or variables to the cartridge.

[F6] FROM - Moves, or transfers, one or more marked files to internal memory from the memory cartridge.

[F7] BACKUP - Backs up, or duplicates, one or more marked files from internal memory to the memory cartridge. A backed up file uses the BAK extension. You cannot backup system files or variables to the cartridge. Only one backup file for a named file may exist.

[F8] RESTORE - Restores one or more marked files with the BAK extension to internal memory from the memory cartridge. The restored file or files do not use the BAK extension.

[F9] HOST - Places you in the Host Menu so that you can communicate with the host. A complete description of this menu appears below under “The HOST Menu - [F9] from the TOOLS Menu.”

[F10] EXIT - Returns you to the top level of the TOOLS menu.

**Using the Cartridge to Manage Memory.** After you load or edit a number of OptiSCREEN files, unused space may appear between the files in memory. The system does not automatically move files to reclaim the unused space. Eventually, file memory can become so fragmented that a new file cannot be stored since the system cannot find a single space large enough for the new file. You can defragment the memory in two different ways:

- If all of the files reside in internal memory, you can install an empty cartridge in the OIT, use the MARK ALL menu item to mark all of the files, use the TO menu item to move all of the files to the cartridge, and then use the FROM menu item to move all of the files to internal memory again.
- If all of the files do not reside in internal memory or file memory is very low, you can use the MARK menu item to mark one or two small files, use the BACKUP menu item to backup the files to the cartridge, use the DELETE menu item to delete the original files, and then use the RESTORE menu item to restore the files to memory. Eventually, you should be able to mark all of the files stored in a single bank, backup the files, delete the original files, and then restore them.

Make sure that you delete the original version of each file before you restore it so that the system does not re-allocate the file in its original location.

File memory on OITs works best if 20% to 30% of the file memory remains available. You should not perform file edits or download files when file space is nearly full.

**[F6] RENAME** - Prompts you to enter the new name for the currently selected file.

**[F7] COPY** - Prompts you to enter the name to which you want to copy the currently selected file. If it does not already exist, the system automatically creates the file that you name for the copy.

**[F8] DELETE** - Deletes one or more marked files. The system queries you to make sure that you have selected the appropriate file or files.

**[F9] HOST** - Places you in the Host Menu so that you can communicate with the host:

HOST										
File Name	Type	Size	Title/Value				Location			
1	RUN TEMP	5004					INT 0:C893			
2	APPLICATIONS	SYSTEM	4x17				INT 1:FF20			
3	CITY	STRING	17				INT 0:DC4D			
4	F1	SYSTEM	3				INT 1:FF0E			
5	JUNKLIST	FILE	10x63				INT 1:EE9F			
6	MYTEST2	SCREEN	128				INT 1:8926			

38400	19200	9600	4800	2400	1200	600	Current Port:	1	2
MAIN	BAUD	MARK	MARK ALL	SEND	RECEIVE			PORT	EXIT
F1	F2	F3	F4	F5	F6	F7	F8	F9	F10

The menu choices, with a summary of what each does, appear below:

**[F1] MAIN** - Returns to the main function bar so that you can make another menu selection. When you return to the HOST menu, the system recalls the screen on which you were working when you pressed the **[F1] MAIN** menu selection.

**[F2] BAUD** - Moves, or rotates, through the list of baud rates that appears above the function bar to specify the rate for your system to send and receive data. The baud rate that you specify appears highlighted above the function bar.

**[F3] MARK** - Marks, or selects, one or more screens or files for transfer, backup, or restoration from the host. Use the cursor control keys to highlight a file, and then mark or select it, by pressing the **[F3] MARK** key. You can then move to another screen or file to be selected; or you can transfer, backup, or restore the selected screens or files. If you previously selected one type of screen or file under the **[F2] TYPES** menu, then the **[F3] MARK** key only marks screens or files of the selected *type*. By selecting a screen or file with the **[F3] MARK** function key a second time, you can unmark, or remove the selection, for a screen or file.

**[F4] MARK ALL** - Marks, or selects, all screen files for transfer, backup, or restoration from the host. If you previously selected one type of screen or file under the **[F2] TYPES** menu, then the **[F4] MARK ALL** key marks all of the selected *type*. By selecting a marked screen or file with the **[F3] MARK** function key, you can unmark, or remove the selection, for a single screen or file.

**[F5] SEND** - Sends one or more marked OptiSCREEN files to the host in ASCII format.

**[F6] RECEIVE** - Receives one or more marked OptiSCREEN files from the host in ASCII format.

**[F9] PORT** - Moves, or rotates, through the list of ports that appears above the function bar to specify the port for your host system. The port that you specify appears highlighted above the function bar.

**[F10] EXIT** - Returns you to the top level of the TOOLS menu.

**[F10] RUN** - Runs the application named on the power-up status line at the bottom of the screen. Specify the application with the **[F1] SETUP** menu from the main menu.

## The CONFIG Menu - [F7] from the Main Function Bar

The Configuration Menu specifies the serial communications parameters, ports, and diagnostic tests for the OIT. You configure your OIT to match the data communication format of the host and equipment that you use. Consult your equipment manual for details on the formats that your equipment requires.

The default Configuration Menu, which is set at the factory before shipping the OIT, appears below:

```

CONFIGURATION

                                Firmware Release 3.1          3APR89

MODE                            ANSI          NO ECHO          SEND ANY CASE
DATE/TIME                       11APR89    NO DISPLAY        14:51 NO DISPLAY
END LINE/COLOR                  WRAP      NO AUTO LF        COLOR
CURSOR/SCREEN                   BLINKING BLOCK      CRT SAVER OFF
STATUS/CONTROLS                 FOUR      7 BIT CONTROLS
PRINT SCREEN                    KEYOFF    GENERIC ASCII     PORT 1
KEYBOARD                        1 TERMINAL
PORT 1                          9600     NONE  8 BIT  1 STOP  SOFT PT TO PT
PORT 2                          9600     NONE  8 BIT  1 STOP  SOFT PT TO PT
PORT 3                          9600     NONE  8 BIT  1 STOP  SOFT
CONFIDENCE TESTS                DIAGNOSTIC

-UP-      -DOWN-      -LEFT-      -RIGHT-      -SELECT-      -PERFORM-      -EXIT-
UP KEY    DOWN KEY    LEFT KEY    RIGHT KEY    SPACE        ENTER        HOME

-----
MAIN      F1      F2      F3      F4      SAVE   RECALL      F7      F8      F9      RUN
          F1      F2      F3      F4      F5      F6          F7      F8      F9      F10
Power-up Status:  DISPLAY MAIN MENU

```

It is easy to specify formats with the Configuration Menu. You use the cursor control keys to advance through the menu items. You use the [Spacebar] to advance, or toggle, through the available option settings for a menu item. You press the [Enter] key to select all of your configuration settings.

The Configuration Menu choices, with a summary of what each does, appear below with the steps for setting the items:

**[F1] MAIN** - Returns you to the main function bar so that you can make another menu selection.

**[F5] SAVE** - Saves the current settings of the Configuration Menu for all future uses. Any previously saved configuration is lost when you press the [F5] SAVE function key.

**[F6] RECALL** - Recalls the last configuration that you stored with the [F5] SAVE function key.

**[F10] RUN** - Runs the application named on the power-up status line at the bottom of the screen. Specify the application with the [F1] SETUP menu from the main menu.

## Configuration Procedure

Each OIT uses a Configuration Menu that reflects the operating functions specific to the OIT and the equipment to which you attach the OIT.

- At the top of the Configuration Menu, a box that describes the revision level and the release date for the firmware appears.
- On the left side of the menu, a list of available OIT modes appears. On the right side of the menu, a status message for each of the modes appears.
- At the bottom of the menu, the four available Configuration Menu functions keys appear.

When you view the Configuration Menu, it displays the current configuration status for the various modes. To change the configuration, follow these steps:

- Use the [Left], [Right], [Up], and [Down] cursor control keys to move the cursor to cover the status option that you want to change.
- Once the cursor covers the status option, press the [Spacebar] to advance through the available options and display the values. Some modes only offer two status options; you toggle through these options. Other modes offer many options; by pressing the [Spacebar] repeatedly, you can rotate through all of the available status options. You can view and change status options any number of times.
- When the system displays the desired status for a mode, you select the status setting by using the cursor control keys to move the cursor to another status option.

To store all of the status options, press the [F5] SAVE function key. After saving the configuration, press the [F1] MAIN or [F10] RUN function key to resume work at the OIT.

After you store the configuration with the [F5] SAVE function key, the OIT automatically enters the saved configuration on power-up, regardless of the configuration it utilized when power was shut down.

Whenever you enter the Configuration Menu, the following events take place:

- The system initializes any IBM PC or PC-XT compatible keyboard connected to the OIT. As part of this initialization, the system turns off the [Caps Lock] and [Num Lock] keys. To avoid improper operation, you must turn off the power before installing or removing the keyboard.
- The system aborts any file storage operation. The system retains any previous version of a file that you saved.
- The system resets all screen attributes.
- The system loses all screen data and clears all input and output buffers.
- The system retains line attributes.

## Configuration Options

By following the procedure described above, the Configuration Menu allows you to select all of the following configuration options. Again, consult your equipment manual for details on the formats that your equipment requires.

## Mode

The Configuration Menu selects the escape sequence type as *ANSI*, *VT100*, or *VT52*. The OIT is an intelligent terminal. In addition to transmitting and receiving data, it responds to a wide variety of screen commands, or escape sequences. The screen commands consist of the ASCII character ESCAPE (27 in decimal) followed by additional characters, which specify parameters.

The American National Standards Institute (ANSI) publishes a set of standards so that equipment designed by all vendors can follow the same set of escape sequence commands. This ANSI standard, X3.64-1979, recommends formats for commands in general and defines commonly used commands.

Few if any terminals (including the OIT) use all of the commands defined by ANSI X3.64, and many terminals (including the OIT) define private commands that expand on the ANSI set. For ANSI compatibility, a device must be able to recognize properly formatted ANSI commands and safely ignore those standardized commands which it does not use. You are responsible for determining that any private ANSI-compatible commands generated by the software are either supported or ignored by the OIT.

The OIT supports numerous commands in the ANSI format, as well as many commands defined by Digital Equipment Corporation for the VT52 and the VT100 display terminals.

## Echoing

The Configuration Menu selects either an *Echo* or *No Echo* mode. *Echo* supports half-duplex mode, and *No Echo* supports full-duplex mode.

When you select *Echo* mode, the system transmits all keystrokes to the host and the OIT takes simultaneous action as if the key codes were returned by the host. When you select *No Echo* mode, the system transmits all keystrokes to the host but the OIT takes no action until the host returns the same key codes.

### Note

Selecting *Multidrop* operation with the communications parameters automatically selects *Echo* mode. You can only select *No Echo* mode when using *Point-to-Point* operation. A remote device can disable the *Echo* mode of the OIT by sending the OIT the Disable Half-duplex command (ESC[\_>4I when the OIT is online.

## Case Sensitivity

The Configuration Menu selects case sensitivity as *Send Any Case* or *Send Upper Case Only*. If you select *Send Any Case*, the system transmits lowercase characters as lowercase characters and uppercase characters as uppercase characters. If you select *Send Upper Case Only*, the system automatically transmits lowercase characters as uppercase letters.

## Set and Display the Date and Time

The Configuration Menu sets the date and the time for the OIT, and specifies whether or not the system displays the date or time, or both, in the bottom right corner of the screen.

To set the date, perform the following steps:

- Move the cursor to cover the date status message.
- Press the [Spacebar] to highlight the day of the month.
- Press the [Spacebar] to advance the day of the month or use the numbers on the keyboard or numeric keypad to enter the correct day.
- Press the [Right] cursor control key to highlight the month.
- Press the [Spacebar] to move through the months until the correct month appears.
- Press the [Right] cursor control key to highlight the year.
- Press the [Spacebar] to advance the year or use the numbers on the keyboard or numeric keypad to enter the correct year.
- Press the [Right] cursor control key twice, once to select the given date and once to move to the date display mode.

To display the date at the bottom right corner of the screen, set the date display mode to *Display*; to turn the date display off, set the mode to *No Display*.

To set the time, perform the following steps:

- Move the cursor to cover the time status message.
- Press the [Spacebar] to highlight the hour of the day.
- Press the [Spacebar] to advance the hour or use the numbers on the keyboard or numeric keypad to enter the correct hour. The system uses a 24 hour clock.
- Press the [Right] cursor control key to highlight the minutes.
- Press the [Spacebar] to advance the minutes or use the numbers on the keyboard or numeric keypad to enter the correct minutes.
- Press the [Right] cursor control key twice, once to select the given time and once to move to the time display mode.

To display the time at the bottom right corner of the screen, set the date display mode to *Display*; to turn the date display off, set the mode to *No Display*.

## End of Line Controls

The Configuration Menu selects the end of line control as either *Wrap* or *No Wrap*. The *Wrap* status setting causes an automatic carriage return and line feed to occur when you specify a character in the 80th column. The *No Wrap* status setting causes a character displayed in the 80th column not to be displayed.

The system also selects *No Auto LF* or *Auto LF* for line feeds. If you select *No Auto LF*, the OIT does not generate a line feed when it processes a carriage return. If you select *Auto LF*, the OIT automatically performs a line-feed when it processes a carriage return. If double line feeds appear on the screen, you should change *Auto LF* to *No Auto LF* since the host is already sending a line feed with each carriage return.

## Color Controls

The Configuration Menu specifies your OIT as a *Monochrome* or *Color* CRT display. You must set the color mode correctly so that your OIT displays colors and intensities in their proper formats.

## Cursor Type

The Configuration Menu selects the cursor type as *No Cursor*, *Blinking Underline*, *Blinking Block*, *Steady Underline*, or *Steady Block*. This mode has no effect on the transfer or processing of data. This mode can also be controlled within an OptiSCREEN statement.

## Screen Control

The Configuration Menu selects the screen control as *CRT Saver On* or *CRT Saver Off*.

If you select *CRT Saver On* and make no changes to the screen display for a period of 4 to 8 minutes, the system “blanks the screen,” or makes the current display invisible, to prevent damage to the phosphor layer on the inside of the tube. By depressing any key, you return the display to the screen. You can press the [Shift] key to restore the display without actually sending any key codes.

If you select *CRT Saver Off*, the screen display remains visible until you turn the power off.

## Number of Status Lines

The Configuration Menu selects 1, 2, 3, or 4 status lines. The status lines act as one line message displays that do not scroll. The top of the display scrolls when the cursor reaches the last line prior to the status line region.

## 7 or 8 Bit Control

The Configuration Menu selects *7 Bit Control* or *8 Bit Control* for ANSI standard codes. If you select the *7 Bit Control* setting, you can choose from 128 total codes. If you select the *8 Bit Control* setting, you can choose from the 128 codes available with the *7 Bit Control* setting or from the additional 128 codes made available by the extra bit. Some communications devices, such as the DEC VT220 terminal, use the extended *8 Bit Control* codes. Consult your equipment manual for details on the formats that your equipment can use.

## Print Screen Control

The Configuration Menu specifies whether or not the [Print Screen] key, or automatic screen printing capability, operates. The [Print Screen] key formats the video screen image and sends it to one of the serial ports for printing or storage. If you specify that the [Print Screen] key operates, you must also specify the format and the port for the output.

If you specify *Key On*, you can press the [Print Screen] key to send the contents of the current screen to a printer. If you specify *Key Off*, the system does not accept the command so that output does not reach the printer.

If you specify *Key On*, you must also specify the format and the port for the output. The system accepts any one of the following graphic drivers for your printer:

Printer	Approximate size of image
GenericASCII	Dependent on your printer
Citoh-3500	3 inches tall by 6 inches wide
Citoh-3500	7 inches tall by 12 inches wide
Citoh-3500	9 inches tall by 6 inches wide*
Proprinter	3 inches tall by 5 inches wide
Proprinter	9 inches tall by 6 inches wide*

\* Image rotated counterclockwise 90 degrees

The system also specifies the serial port as *port 1* or *port 2*.

The [Print Screen] key code is 0AAH (170). The standard full-travel keyboard already offers this key, or you can program a key on any of the membrane keyboards to use this code.

The system performs the [Print Screen] command as a background process. Normal operations continue while the system prints the image. The only condition under which the OIT waits is when you issue a [Print Screen] command before a previous [Print Screen] command is completed.

The [Print Screen] printer task processing and the normal OIT processing occur concurrently. This concurrent operation allows video images to be captured in hardcopy form while the OIT actively monitors a real time process:

- When you initiate [Print Screen], the system makes a copy of the current video image and stores it in reserved system memory.
- The system activates an interrupt-driven background printer task. The background printer task scans the copy of the video image, converts the character codes into printer graphic data, and transmits the data to the printer.
- The system then returns to the process that initiated the [Print Screen].

The printer task terminates itself after the printer completes the image.

## Keyboard Control

The Configuration Menu describes the type of keyboard your OIT uses during normal operation: 1 *Terminal*, 2 *BASIC*, 3 (*Not supported*), 4 *QWERTY*, 5 *Programmable*, or 6 (*Not supported*). The system assumes that you are using a sealed-membrane keyboard.

The *Terminal*, *BASIC* and *QWERTY* keyboard layouts appear in Chapter 1 of this Guide. The *Programmable* keyboard allows you to define the keys and key codes sent when you press one of the keys on the 65-position keyboard or the 34-position built-in keyboard.

## Communications Parameters

The Configuration Menu selects the baud rate, the parity, the word length, the number of stop bits, the type of handshaking, and the type of communications (point-to-point or multidrop) for the OIT. All status settings, except for the baud rate, can be set separately for Port 1, Port 2, and Port 3:

- **Baud Rate:** Select the baud rate as *50 baud, 110 baud, 134.5 baud, 150 baud, 200 baud, 300 baud, 600 baud, 1050 baud, 1200 baud, 1800 baud, 2000 baud, 2400 baud, 4800 baud, 9600 baud, 19.2K baud, or 38.4K baud*. Both ports must be operated at the same baud rate.
- **Parity:** Select the parity as *Space, None, Odd, Even, or Mark*.

Use the *Space* and *Mark* parity settings with 7-bit word length settings; you can not use *Space* and *Mark* with the 8-bit word length. Use the *Even, Odd, and None* parity settings with either the 7-bit or 8-bit word lengths. The use of *Space*, or zero, parity is not the same as *None* parity with 8 data bits.

- **Word Length:** Select the word length as either *7 bits* long or *8 bits* long depending on the needs of your equipment.
- **Stop Bits:** Select the number of stop bits as either *1 Stop* bit or *2 Stop* bits. If your host or equipment runs at a rate of 110 baud or lower, you should generally select *2 Stop* bits. For higher baud rates, select *1 Stop* bit. Your host or equipment may require a specific setting for the number of stop bits.
- **Handshaking:** Select handshaking as either *Hard* or *Soft* for hardware or software handshaking.

If your equipment does not support either hardware or software handshaking, configure the OIT for hardware handshaking and wire the port as shown in Chapter 3. When you use this configuration, you must take care to avoid overflowing the input buffer. Chapter 3, “Installation,” contains more information on handshaking.

Port 3 (secondary port alternate connection) handshaking options are *Soft* or *None*.

- **Communication Type:** Select the online communication type as *Point-to-Point* or *Multidrop* communications for the primary and secondary ports:

Port 3 (secondary port alternate connection) operates in *Point-to-Point* communications mode only and is not selectable.

- The *Point-to-Point* communication mode uses either software or hardware handshaking. The *Point-to-Point* communication mode accepts either RS-232 or RS-422 signals.
- The *Multidrop* communication allows a host to communicate with up to 15 terminal addresses, all on the same RS-422 multidrop line. The *Multidrop* communication mode automatically selects *Echo* operation.

When you select the *Multidrop* mode and your host does not support software handshaking, you should select hardware handshaking although it may not be used. In this case, jumper pin 5 to pin 20 on the OIT primary or secondary port. See Chapter 3, “Installation,” for more information on multidrop wiring and handshaking.

To set the communication type, perform the following steps:

1. Move the cursor to cover the communication type status message.
2. Press the [Spacebar] to change the communication type from *Point-to-Point* to *Multidrop*, or to change from *Multidrop* to *Point-to-Point*.

To move between these two types, you use the cursor control keys (such as [Left] and [Right]) to move off the communication type and back onto the communication type; you cannot use the [Spacebar] to toggle between the two types.

After selecting *Point-to-Point* communication, press the [Right] cursor control key to move to the next port configuration mode.

3. To change the terminal number with *Multidrop* communications, press the [Spacebar] to advance the first digit of the terminal or use the numbers on the keyboard or numeric keypad to enter the correct first digit.
4. Press the [Right] cursor control key to highlight the second digit of the terminal.
5. To change the second digit, press the [Spacebar] to advance the number or use the numbers on the keyboard or numeric keypad to enter the correct second digit.
6. To select the terminal number for *Multidrop* communication, press the [Right] cursor control key twice, once to select the given communication type and once to move to the next port configuration mode.

## Confidence Tests

The Configuration Menu selects a number of tests which confirm the correct operation of the OIT: a *Diagnostic* test, a *Communication* test, a *Test Pattern*, an *Extended Memory* test, and a *Manufacturing Cycle* test:

- The *Diagnostic* test causes the system to perform the power-up diagnostics continuously until failure occurs or until you press any key.
- The *Communication* test requires that the transmit and receive lines for each port be jumpered together. The CTS and RTS signals should also be connected. This test can be performed at any baud rate, and with either RS-232 or RS-422 signals. In the event of a failure, the system displays a failure code:

Error	Port (Connection)	Failure	Test Data
11	Primary (J1)	No data received	55H
12	Primary (J1)	Wrong data received	55H
13	Primary (J1)	No data received	6AH
14	Primary (J1)	Wrong data received	6AH
15	Primary (J1)	CTS did not turn off	
16	Primary (J1)	CTS did not turn on	
21	Secondary (J2)	No data received	55H
22	Secondary (J2)	Wrong data received	55H
23	Secondary (J2)	No data received	6AH
24	Secondary (J2)	Wrong data received	6AH
26	Secondary (J2)	RTS did not turn off	
27	Secondary (J2)	RTS did not turn on	

After receiving a failure code, you must reset the OIT before restarting the test.

- The *Display Test Pattern* setting displays a pattern on your screen so that you can adjust the OITs CRT controls.
- The *Extended Memory* test checks your user memory. Use caution when running this test, since a reset or power interruption during the test can cause the stored user memory to be modified.
- The *Manufacturing Cycle* test causes the OIT to run the Diagnostics test, the Communications test, and the Extended Memory test one after the other.

## The ONLINE Item - [F8] from the Main Function Bar

Specifies that the system enters the Online mode for communication.

## The LOCAL Item - [F9] from the Main Function Bar

Specifies that the system enters the Local mode for testing and operation.

## The RUN Item - [F10] from the Main Function Bar

This menu item executes the application named on the power-up status line at the bottom of the screen. You can change the application by entering the [F1] SETUP menu item from the main function bar.

## Keyboard Operation

The keyboard sends data to your OIT or the screen. The screen contains 2000 character positions in a matrix of 25 lines by 80 characters positions. A single character occupies a character position at any given time and remains there until the system replaces or erases it.

### Alphabetic Keys

The 65-position sealed keyboard automatically sends uppercase letters unless you simultaneously press the [Shift] key, which causes lowercase letters to be sent. An IBM PC or PC-XT-compatible keyboard sends either uppercase or lowercase letters depending on the state of the [Shift] and [Caps Lock] key. If you configure the OIT for *Upper Case Only* in the Configuration Menu, the OIT sends only uppercase letters.

## Nonalphabetic Keys

Nonalphabetic keys are those with double markings. These include the numbers 0 through 9, punctuation marks, and special characters. The system generates the lower marking when you do not depress the [Shift] key; it generates the upper marking when you depress the [Shift] key.

## Cursor Keys

The cursor control keys (or “arrow keys” labeled [Up], [Down], [Left], and [Right] on the keypad) and the [Home] key transmit an escape sequence corresponding to their particular function when they are pressed. The actual escape sequence follows either the ANSI standard or VT52 or VT100 emulation standard, depending upon the mode you specified for the OIT.

As with all other keys, the OIT does not perform the function associated with the keys unless the host device echoes the data back, or you configured the OIT for *Echo* operation.

When the system executes an OptiBASIC program, you can use the INKEY statement to read in the cursor keys as unique non-ASCII 8-bit codes. When you use the OIT with other hosts that execute some form of BASIC, the escape sequences sent by cursor keys are sometimes difficult to use. In this case, you can send the a command (ESC [ \_> 15 h) to the OIT to totally disable the cursor keys so that they do not transmit any codes.

## Function Keys

Depending upon the keyboard, up to 15 separate function keys may be available. On some keyboards, fewer function keys are shown, but in conjunction with the [Shift] and [Ctrl] keys, a total of 16 function keys are accessible:

Key	Unshifted	[Shift]	[Ctrl]	[Shift]-[Ctrl]
F1	[F1]	[F5]	[F9]	[F13]
F2	[F2]	[F6]	[F10]	[F14]
F3	[F3]	[F7]	[F11]	[F15]
F4	[F4]	[F8]	[F12]	[F16]

The function keys generate a sequence of key strokes that either the OIT or a remote host can use to perform unique operations that could not otherwise be performed by a single ASCII code.

For all OITs in the Local mode, the function keys generate predefined escape sequences that select or change screen and character attributes. In the Online and BASIC modes, the function keys transmit or generate a user-programmed sequence of one to sixteen characters.

The OITs [F1] through [F4] function keys correspond to the DEC VT100 terminal's PF1 through PF4 keys.

## Miscellaneous Keys

The following key characteristics apply only to the OITs internal handling of the listed functions. In *No Echo* operation, functions such as [Return], [Line Feed], [Spacebar], [Backspace], [Del], and so on, are transmitted to the host and are acted on by the OIT only if the host retransmits the same functions back:

**[Return]** - moves the cursor to the first character position of the line on which it currently rests. If the cursor already rest at the first character position, it remains there. [Return] generates a line feed if you specified *Auto LF*

**[Line feed]** - moves the cursor down one line. If the cursor rests on the bottom line, a line feed causes it to remain there but all of the data on the screen moves up one line. The screen loses data on the top line as it scrolls up and off the screen. [Line feed] generates a [Return] if you specified *Auto CR*.

**[Spacebar]** - causes the cursor to move one character position to the right. If the cursor was positioned on a displayed character, the system replaces it with a space. When a [Spacebar] occurs at the end of the line, the cursor remains there unless you select *Auto Wrap*.

**[Backspace]** - moves the cursor one space to the left. If the cursor rests at the left end of the line, the cursor does not move. Many forms of software use this key to delete the last input character.

**[Del]** - transmits the ASCII code 7F (Hex) as a nondisplayable character. The host computer software may use this to generate its own functions.

**[Repeat]** - causes any other key simultaneously pressed to be repeatedly transmitted at either 15 characters per second or at the baud rate, whichever is less. On IBM PC or PC-XT-compatible keyboards, as well as sealed-membrane keyboards used with the OIT, all keys start repeating after being depressed for approximately one-half second.

**[Esc]** - is a nondisplayable character that transmits the ASCII code 1B in hex (or 27 in decimal). Use this key in combination with other keys to enter OIT commands. These commands change screen attributes, move the cursor, store and recall screens, and perform many other operations described throughout this guide.

**[Break]** - generates a continuous “space level” output. The [Break] key must be enabled for this to happen. Generally, the [Break] key tells the host computer that you wish to interrupt execution.

**[Reset]** - when pressed at the same time as the [Shift] key, resets the OIT to its power-up condition and clears the display. The OIT also supports an external input which may be connected at the rear OIT strip. You can use the [Shift]-[Reset] key combination to allow reset control from external equipment.

**[Print Screen], or [Prt Scr]** - performs a “print screen” operation to the primary or secondary port. The [Print Screen] key must be enabled for this to happen. A complete description of this operation appears above under the “Print Screen Control” heading of the Configuration Menu.

## Control Keys

You can hold down the [Ctrl] key in combination with other keys to send the 32 ASCII control codes (0-31). Refer to the “ASCII Codes and Special Character Sets” chart in Appendix B of this guide for a listing of the control keys. All of these [Ctrl] key combinations are non-displayable characters. The OIT responds to only nine of the control characters:

**Bell (BEL or [Ctrl]-G)** - causes the OIT to generate a one-half second signal to the bell terminals on the back of the OIT.

**Backspace (BS or [Ctrl]-H)** - duplicates the [Backspace] key.

**Tab (HT or [Ctrl]-I)** - uses software control to move the cursor to the next tab stop to the right. The tab stops are fixed eight character spaces apart at columns 9, 17, 25, 33, 41, 49, 57, 65, and 73. If the cursor rests in columns 73 through 79, each time you press Tab, the cursor only moves one character position to the right. If the cursor rests at column 80, it does not move.

**Line feed (LF or [Ctrl]-J)** - duplicates the [Linefeed] key.

**Carriage return (CR or [Ctrl]-M)** - duplicates the [Return] key.

**Shift out ([Ctrl]-N)** - enters the supplemental graphics mode for the current character set.

**Shift in ([Ctrl]-O)** - exits the supplemental graphics mode for the current character set.

**Cancel ([Ctrl]-X)** - stops executing the current Escape sequence.

**Escape (ESC or [Ctrl]-I)** - duplicates the [Esc] key. In addition to these standard [Ctrl] key combinations, OIT accepts the [Ctrl]-1 combination to cause the OIT to return to the Main OptiVIEW menu.

# Chapter 5

## *OptiSCREEN Command Reference*

---

---

By using the OptiSCREEN editor and commands, the OIT functions as an independent device which can handle screen update and communications to a PLC.

You specify OptiSCREEN commands to make up an OptiSCREEN file. The OptiSCREEN editor converts each of the commands to its corresponding internally-stored escape code. The OptiSCREEN editor was developed to make screen file programming easier, faster, and more efficient.

### **OptiSCREEN Command Types**

The thirteen major types of OptiSCREEN commands are briefly described below.

#### **Comment and End of File**

The comment sets off text as documentation for the screen file. Any comment found on the first line of an OptiSCREEN file also appears when you display the directory. Comments also identify the purpose of commands and sections of files for yourself and other users. The OptiSCREEN editor automatically inserts the END command at the end of each OptiSCREEN file.

#### **Configuration**

These change the way the OIT communicates and processes text. Each configuration command offers a corresponding command on the configuration menu. Examples of configuration commands include AUTO WRAP AT END OF LINE and NO AUTO WRAP.

#### **Cursor**

These commands control the appearance and location of the cursor on the screen. During operation, the location of the cursor determines the starting position for text and graphics on the screen. Examples of cursor commands include NO CURSOR and the MOVE TO command.

#### **Character Attribute**

These change the video attributes of all characters displayed after the command. Examples of character attribute commands include BLINK, SUPPLEMENTAL, QUAD, BLUE, and /WHITE.

#### **Line Attribute**

These set the video attributes for a single line of text on the screen. Examples of line attribute commands include DOUBLE SIZE LINE and DOUBLE WIDE LINE.

## Clock and Date

These specify whether or not the date and time appear at the bottom of the screen in the OptiSCREEN status line. Examples of clock and date commands include DISABLE DATE and ENABLE DATE.

## Display

The DISPLAY command is one of the most commonly used commands in the OptiSCREEN editor. You can generate text and graphics for your application with the DISPLAY command.

## File Display

The file display commands display other screen files, allowing you to “call” other OptiSCREEN files, file memory, or a directory of files. Examples of the file display commands include DISPLAY FILE and DISPLAY FILE MEMORY.

## Erasing and Editing

The erasing and editing commands allow you to perform a number of operations that edit text and graphics which already appear on the screen: clear the screen or a portion of the screen, insert new text, or specify a scrolling region for text or graphics. Examples of erasing and editing commands include CLEAR SCREEN, CLEAR STATUS LINES, DELETE LINE, and SCROLL UP.

## Graphics

The graphics commands draw boxes, change the video attributes for boxed regions of the screen, and draw bar graphs. Examples of graphic commands include BOX, EMPTY BOX, BOX ATTRIBUTES, and HORIZONTAL BARGRAPH.

## Programmable Keyboard and Function Key

These commands allow you to set and use the programmable keyboard and function key capabilities of an OIT. Examples of these commands include CLEAR KEY TABLE, DISPLAY KEY TABLE, and LOAD KEY. The LOAD FUNCTION KEY command loads the available function keys for a OIT.

## Data Transmissions and Port Control

These commands control data transmissions and output from the serial ports. Examples of these commands include PRINT SCREEN and BAUD.

## VIEW Commands

The VIEW commands are only available with the OIT with OptiBASIC. The new VIEW commands give you more powerful and easier-to-use graphics capabilities than previously available. These commands automatically animate data, allowing you to generate a changing graph or graphic display with a single command. Examples of VIEW commands include GRAPH RIGHT, and VIEW data.

An alphabetic summary of the individual commands, usable as an index, appears at the end of the chapter.

## Data Fill Operations

You may create an OptiSCREEN file with numerous blanks left for the host to fill with data. The file creation and appending procedures allow you to create the screen file using the [Ctrl]-E (ENQ, enquiry) control character for the locations on the screen where the system displays data.

## Conventions for the OptiSCREEN Commands

This summary lists and describes all of the commands used in the OptiSCREEN editor. All [nb]OptiSCREEN command listings follow the format shown below:

### COMMAND FORM {ESC}xxx

A short description of the command follows the headline command form. Elements that appear in UPPERCASE LETTERS of the command form are required elements of the command. Elements that appear in lowercase letters are parameters that you supply. A summary of acceptable parameters appears in the description.

Example: A short explanation appears before the example of the command.

```
OPTISCREEN COMMAND 1
OPTISCREEN COMMAND 2
...
OPTISCREEN COMMAND n
```

Each of the OptiSCREEN commands appear under the heading in which the command is summarized above. An alphabetic summary of the individual commands appears at the end of the chapter.

## The Comment Command and the End of File Command

The comment command and the end of file command are two important commands for the OptiSCREEN system.

### 'comment

OptiSCREEN treats all text following an apostrophe (') as a comment.

**comment** specifies that the rest of the line is a comment. You can only place the comment at the beginning of the line.

When you make the first line of an OptiSCREEN file a comment, the first 25 characters of the comment line also appear when you generate a directory of OptiSCREEN files.

Example: Give a comment that you might want to place as the first line of an OptiSCREEN file. When you generate a directory of OptiSCREEN files, the system labels this file as Fluid Level, Tanks 1,2,3:

```
'Fluid Level, Tanks 1,2,3
```

### END {EOT}

The END command indicates the end of the OptiSCREEN screen file. The OptiSCREEN editor automatically adds the END command to each file that you create.

## Configuration Commands

The configuration commands change the way the OIT communicates and processes text. Each configuration command offers a corresponding command which you can set in the Configuration Menu as the default.

**AUTO LINE FEED ON RETURN {ESC}[>8h**  
**NO AUTO LINE FEED {ESC}[>8l**

The AUTO LINE FEED ON RETURN command forces an automatic line feed to occur with a carriage return. It is rarely used since most host devices already generate a line feed with a carriage return.

The NO AUTO LINE FEED command disables the automatic line feed that usually occurs with a carriage return; it is the opposite of the AUTO LINE FEED ON RETURN command.

**AUTO RETURN ON LINE FEED {ESC}[9h**  
**NO AUTO RETURN {ESC}[9l**

The AUTO RETURN ON LINE FEED command forces an automatic carriage return that occurs with a line feed. It is rarely used since most host devices already generate a carriage return with a line feed.

The NO AUTO RETURN command disables the automatic carriage return that occurs with a line feed; it is the opposite of the AUTO RETURN ON LINE FEED command.

**AUTOWRAP AT END OF LINE {ESC}[?7h**  
**NO AUTO WRAP {ESC}[?7l**

The AUTO WRAP AT END OF LINE command forces automatic line wrapping to occur at the end of a filled line. The screen scrolls up to wrap, if necessary. This command is useful when you use a host device sending a series of ASCII characters without line feeds or carriage returns.

The NO AUTO WRAP command disables the automatic line wrapping facility at the end of lines. After the 80th character in a line, characters overprint so that only the last character received in column 80 appears. This command is the opposite of the AUTO WRAP AT END OF LINE command.

**BAUD nnn {ESC}[ nnn W**

This command sets the programmable series communications baud rate for the current operation.

**nnn** - specifies the baud rate. You must specify nnn as one of the following rates: 50, 110, 134, 150, 200, 300, 600, 1050, 1200, 1500, 2000, 2400, 4800, 9600, 19200, or 38400. (The baud rate 134 actually sets a rate of 134.5 baud.)

All serial ports on the OIT use the same programmed baud rate. You should pause communications for a minimum of one second after you issue the BAUD command to allow time for the serial ports to begin use of the selected baud rate. Your OIT may require additional pause time if you sent commands or data to it immediately prior to the BAUD command. This is necessary since your OIT buffers commands and data at the same time that the host sends the BAUD command.

Example: Change the baud rate to 1200 baud for a printer.

BAUD 1200

## Cursor Commands

The cursor commands control the appearance of the cursor and specify the location for the cursor on the screen. During operation, the location of the cursor determines the starting position for text and graphics on the screen.

### Controlling the Appearance of the Cursor

The following commands determine whether or not the cursor appears on the screen, the appearance of the cursor, and the blinking or non-blinking characteristics of the cursor:

**CURSOR or ENABLE CURSOR {ESC}[>5I**  
**NO CURSOR or DISABLE CURSOR {ESC}[>5h**

The CURSOR and ENABLE CURSOR commands make the cursor visible so that it appears on the screen. The two commands are identical.

The NO CURSOR and DISABLE CURSOR commands disable the cursor so that it does not appear on the screen. The two commands are identical.

**BLOCK CURSOR {ESC}[>4h**  
**UNDERLINE CURSOR {ESC}[>4I**

The BLOCK CURSOR command makes the cursor appear as a solid block on the screen.

The UNDERLINE CURSOR command makes the cursor appear as an underline character on the screen.

**BLINKING CURSOR {ESC}[>11I**  
**STEADY CURSOR {ESC}[>11h**

The BLINKING CURSOR command makes a block or underline cursor blink as it appears on the screen. To make a block of text blink, use the BLINK command.

The STEADY CURSOR command makes a block or underline cursor non-blinking as it appears on the screen.

### Controlling the Location of the Cursor

The following commands determine the location of the cursor on the screen.

**HOME {ESC}[H or {ESC}[f**

The HOME cursor command moves the cursor to the home position at row 1 and column 1.

Example: The underlined number 1 appears in the home position below.

```

1234567891111111111222222222233333333334444444445555555556666666667777777778
2      01234567890123456789012345678901234567890123456789012345678901234567890
3
4      < < < Columns 1 through 80 > > >
5
6
7
8
9
10     _ MOVE TO 10, 40
11     ^
12     ^
13     ^
14     Rows
15     1      _ DOWN 5      _ RIGHT 15
16     through
17     25
18     ^
19     ^
20     ^
21
22
23
24
25

```

**MOVE TO rr, {ESC}[ rrr f**  
**MOVE TO rr, cc {ESC}[rrr;ccc f or {ESC}[rrr;ccc H**

This command positions the cursor on the screen at a specified row and column position.

**rr** - specifies row 1 to 25, inclusive. If you specify a row that does not exist, the cursor remains in the current row.

**cc** - specifies column 1 to 80, inclusive. If you do not specify a column, the cursor moves to row rr and column 1. If you specify a column that does not exist, the cursor moves to column 80.

Example 1: Move the cursor to row 10 and column 40.

```
MOVE TO 10, 40
```

Example 2: Both of the following commands move the cursor to row 20 and column 1.

```
MOVE TO 20,
MOVE TO 20, 1
```

**DOWN {ESC}[B**  
**DOWN nn {ESC}[ nnn B**

This command moves the cursor down the screen.

**nn** - specifies the number of rows to move. If you do not specify the number of rows, this command moves the cursor down one row.

A screen always contains 25 rows. If the cursor is in row 25, it remains there.

Example: Move the cursor down 5 lines.

DOWN 5

**UP {ESC}[A**  
**UP nn {ESC}[ nnn A**

This command moves the cursor up the screen.

**nn** - specifies the number of rows to move. If you do not specify the number of rows, this command moves the cursor up one row.

A screen always contains 25 rows. If the cursor is in row 1, it remains there.

Example: Move the cursor up four rows.

UP 4

**LEFT {ESC}[D**  
**LEFT nn {ESC}[ nnn D**

This command moves the cursor to the left.

**nn** - specifies the number of columns, or character cells, to move. If you do not specify the number of columns, this command moves the cursor left one column.

A screen always contains 80 columns. If the cursor is in column 1, it remains there.

Example: Move the cursor left seven spaces.

LEFT 7

**RIGHT {ESC}[C**  
**RIGHT nn {ESC}[ nnn C**

This command moves the cursor to the right.

**nn** - specifies the number of columns, or character cells, to move. If you do not specify the number of columns, it moves the cursor one column to the right.

A screen always contains 80 columns. If the cursor is in column 80, it remains there.

Example: Move the cursor right six spaces.

RIGHT 6

**INDEX {ESC}D**

This command invokes the line feed to move the cursor down one row. If the cursor is on the bottom row, it remains there.

**REVERSE INDEX {ESC}M**

This command reverses the line feed to move the cursor up one row. If the cursor is on the top row, it remains there and scrolls text on the screen down one line.

**NEW LINE {ESC}E**

This command moves the cursor down one row and automatically moves to the beginning of the new line.

**LINE rr {ESC}[ rrr f or {ESC}[ rrr H**

This command moves the cursor to the beginning of specified line 1 to 25, inclusive.

**rr** - specifies the line, or row, number.

A screen always displays 25 rows.

Example: Move the cursor to row 4, column 1.

```
LINE 4
```

**SAVE POSITION {ESC}7 or {ESC}[s  
RESTORE POSITION {ESC}8 or {ESC}[u**

The SAVE POSITION command stores the current location of the cursor so that you can return to that location. The RESTORE POSITION command returns the cursor to the stored location.

Example: Display an OptiSCREEN file. After the system displays the file, store the position of the cursor, display two other files, and then return to the stored position that you specified earlier.

```
DISPLAY FILE 10
SAVE POSITION
DISPLAY FILE 21
DISPLAY FILE 22
RESTORE POSITION
```

## Character Attribute Commands

Character attribute commands change the video attributes of all characters displayed after the command. The first set of character attribute commands described below define the attributes for both color and monochrome OITs. The second set of commands define attributes for color OITs only. The third set define attributes for monochrome OITs only. Finally, the ATTRIBUTE command defines character attributes that affect both color and monochrome OITs by changing the appearance and color or intensity for color or monochrome OITs.

## Attributes for Both Color and Monochrome OITs

These commands define the character attributes for both color and monochrome OITs.

### **BLINK {ESC}[5m** **EXIT DOUBLE WIDE AND BLINK {ESC}[22m**

The BLINK command establishes blinking as the current character attribute mode. After you issue the BLINK command, all subsequent text and graphics slowly flash off and on. (To make the cursor blink, use the BLINKING CURSOR command.)

The EXIT DOUBLE WIDE AND BLINK character attribute command resets the double wide and blink character attributes to normal. This command does not change the foreground or background intensity. The RESET ATTRIBUTES command resets the blink condition as well as all character attributes to the default: normal size, normal color or intensity, no underlining, and no reversed colors or intensities.

Example: Create a single line text message with only the word Warning blinking.

```
MOVE TO 10, 15
BLINK
DISPLAY "WARNING "
EXIT DOUBLE WIDE AND BLINK
DISPLAY "OVEN TEMPERATURE HIGH!"
```

### **REVERSED {ESC}[7m**

The REVERSED command establishes reverse video as the current character attribute mode; normally the characters appear as a light character on a dark background. On monochrome OITs, the background intensity level (bright, dim, or normal) appears the same as the previously specified foreground. On color OITs, both the foreground and background colors usually change, although they are not always “reversed;” for example, a black foreground on a red background does not reverse to red on black. Many of the foreground colors reverse to black or blue, and many of the background colors reverse to green or cyan.

The RESET ATTRIBUTES command resets the reversed attribute as well as all character attributes to the default: normal size, normal color or intensity, no blink, and no underlining.

Example: Display a two line message. Make the second line use reversed characters to highlight it.

```
MOVE TO 10, 28
DISPLAY "Crusher not moving"
REVERSED
MOVE TO 12, 20
DISPLAY "Check with operator for information"
RESET ATTRIBUTES
```

### **SUPPLEMENTAL {ESC}[11m or {SO}** **EXIT SUPPLEMENTAL {ESC}[10m or {SI}**

The SUPPLEMENTAL command establishes the supplemental character set as the current character attribute mode. The supplemental character set consists of the

numbers from 0 to 9, the uppercase letters from A to Z, most punctuation marks, and 33 supplemental graphics characters. You specify the supplemental graphics with lowercase letters from a to z and special symbols. A summary and comparison of the standard, supplemental, alternate, quad, and double wide characters appears at the end of the discussion of these characters.

The EXIT SUPPLEMENTAL command exits the supplemental character set. This command does not change any other character or line attribute settings.

Example: Display a small box generated with supplemental characters.

```
MOVE TO 10, 20
SUPPLEMENTAL
DISPLAY "lk"
MOVE TO 11, 20
DISPLAY "mj"
EXIT SUPPLEMENTAL
```

**QUAD SIZE {ESC}[16m**  
**EXIT QUAD {ESC}[17m**

The QUAD SIZE command establishes quad size characters as the current character attribute mode. All characters and symbols cover the positions from the cursor to the right four character cells and up four lines. Unused character cells do not erase previous data on the screen. Therefore, connecting lines used in graphic displays remain visible after the quad size symbol appears.

The quad size character set includes the capital letters A through Z, the numerals 0 through 9, and the comma (,), the period (.), the asterisk (\*), the plus sign (+), the minus sign (-), the equals sign (=), the slash (/), and the question mark (?). A number of quad size symbols can be generated by using lowercase letters a through l, and special symbols. A summary and comparison of the standard, supplemental, alternate, quad, and double wide characters appears at the end of the discussion of these characters.

Quad size characters in column 78, 79, and 80 wrap to the next available row (four rows below the current row) and scroll, if necessary, after you specify WRAP AT END OF LINE. This allows you to use the OIT as a quad size message display. After you specify quad size characters, text information sent to the OIT in online mode is correctly displayed and scrolled even when the message exceeds a line or the screen size.

The combination of QUAD SIZE and DOUBLE WIDE attributes create characters which appear eight columns wide and four rows tall. Quad size and double wide characters wrap to the next available row and scroll, if necessary, after you specify WRAP AT END OF LINE.

The EXIT QUAD command exits the quad size character set. This command does not change any other character or line attribute settings.

Example: Display a message in quad-sized letters and then exit the QUAD character attribute mode.

```
QUAD SIZE
DISPLAY "IN PROGRESS"
EXIT QUAD
```

## **ALTERNATE {ESC}[12m** **EXIT ALTERNATE {ESC}[13m**

The ALTERNATE command establishes the alternate character set as the current character attribute mode. The alternate character set consists of 128 graphics characters. You specify the alternate character set with the numbers from 0 to 9, the uppercase letters from A to Z, the lower case letters from a to z, and the special symbols.

The supplemental alternate character set gives you a number of additional special graphic symbols. A summary and comparison of the standard, supplemental, alternate, and quad character sets appears at the end of the discussion of these characters.

The EXIT ALTERNATE command exits the alternate character set.

Example: Display two characters from the standard character set and then display a graphic symbol (an ascending diagonal line) from the alternate character set.

```
LINE 10
DISPLAY "lm"
ALTERNATE
DISPLAY "lm"
UP
DISPLAY "lm"
EXIT ALTERNATE
```

## **DOUBLE WIDE {ESC}[15m** **EXIT DOUBLE WIDE AND BLINK {ESC}[22m**

The DOUBLE WIDE command establishes double wide characters as the current character attribute mode. The cursor automatically increments two positions for both characters and spaces, but only increments one position for the backspace character. Cursor movements are still performed one position at a time although the position after the double wide character does not appear. Double wide characters in column 80 wrap to the next row and scroll, if necessary, after you specify WRAP AT END OF LINE. A summary and comparison of the standard, supplemental, alternate, quad, and double wide character set appears at the end of the discussion of these characters.

The combination of DOUBLE WIDE and QUAD SIZE attributes create characters which appear eight columns wide and four rows tall. Double wide and quad size characters wrap to the next row and scroll, if necessary, after you specify WRAP AT END OF LINE.

The EXIT DOUBLE WIDE AND BLINK command resets the double wide and blink character attributes to normal. The RESET ATTRIBUTES command does NOT reset the DOUBLE WIDE command to normal.

Example: Display double wide text and then return to the normal character attribute mode.

```
DOUBLE WIDE
MOVE TO 5, 10
DISPLAY "New Instructions"
MOVE TO 7, 20
EXIT DOUBLE WIDE AND BLINK
DISPLAY "For Loading"
```

## Comparison of Various Character Attribute Modes

The following chart shows the similarities and the differences between the ASCII codes and the standard, supplemental, quad size, alternate, and supplemental alternate character modes. (Drawings of the graphics characters appear in Appendix B.) To use the chart, determine the ASCII code for the character that you want to print, find the column that holds the number, and look down the column to see the various outputs available for the character in the different modes.

For example, the letter A is ASCII number 65. In standard, supplemental, and quad size character mode, it produces the uppercase letter A. In alternate and supplemental alternate character mode, it produces a graphics character for the upper part of a circle.

The letter a is ASCII number 97. In standard character mode, it produces the lower letter a. In supplemental character mode, it produces a “checker board” pattern. In quad size mode, it produces the graphics character for a transformer. In alternate character mode, it produces a graphics character for the lower part of a half circle. In supplemental alternate character mode, it produces an angular shape.

The caret (^) is ASCII number 94. In standard character mode, it produces a caret. In supplemental character mode, it produces a vertical bar. In alternate character mode, it produces a graphics character for the upper part of a half circle. In supplemental alternate character mode, it is blank. In quad size mode, it produces a quad size “up arrow” graphics character.

Character	ASCII	ASCII	ASCII	ASCII	ASCII	ASCII	ASCII
Standard	0 to 9	A to Z	a to z	space ! " # \$ % & ' ( ) * + , - . /	: ; <=> ? @	[ \ ] ^ _ `	{   } ~
Supple- mental Standard	0 to 9	A to Z	graphics	space ! " # \$ % & ' ( ) * + , - . /	: ; <=> ? @	[ \ ] and graphics	graphics
Quad Size	0 to 9	A to Z	graphics and blank	space ! * + , - . / and graphics	= ? and graphics	graphics	blank
Alternate	graphics	graphics	graphics	graphics	graphics	graphics	blank
Supple- mental Alternate	same graphics	same graphics	different graphics	same graphics	same graphics	different graphics	blank

ASCII codes are decimal representations. Drawing of the graphics characters appear in Appendix B.

## RESETATTRIBUTES {ESC}[m or {ESC}[0m

The RESET ATTRIBUTES command resets all character attributes to the default: normal size, normal color or intensity, no blink, no underlining, and no reversed colors or intensities. The RESET ATTRIBUTES command does not change the character set from alternate, supplemental, or quad; nor does it affect line attributes.

You can specify a new default

## SETDEFAULT ATTRIBUTE {ESC}[X

This command defines the currently set character attributes, including color or intensity attributes, as the new default attributes. Use this command with the RESET ATTRIBUTES command to control the default attributes for your application.

Example: Display text to show the default color settings for your OIT before you set a new default. Set a new default. Change the color setting again and then return to your new default setting.

```
CLEAR SCREEN
MOVE TO 8, 10
DISPLAY "Default settings"
YELLOW
MOVE TO 10, 10
DISPLAY "Yellow foreground"
SET DEFAULT ATTRIBUTE
RED
/BLUE
MOVE TO 12, 10
DISPLAY "Red on blue"
RESET ATTRIBUTES
MOVE TO 14, 10
DISPLAY "New default"
```

### Attributes for Color OITs Only

All of the following commands are valid only on units with the COLOR option saved on the configuration menu. With all of the following colors, you use the foreground color (such as BLACK or RED) to specify the color for the text or graphics. You use the background color (such as /BLUE or /GREEN) to specify the color for a region.

The RESET ATTRIBUTES command resets all character attributes to the default colors.

## BLACK {ESC}[30m /BLACK {ESC}[40m

The BLACK command sets the foreground color to black. /BLACK sets the background color to black.

Example: Display black text on a red background.

```
BLACK
/RED
DISPLAY "Black foreground with red background"
```

**BLUE {ESC}[34m**  
**/BLUE {ESC}[44M**

The BLUE command sets the foreground color to blue. /BLUE sets the background color to blue.

Example: Display blue text on a yellow background.

```
BLUE
/YELLOW
DISPLAY
"Blue text, yellow background."
```

**CYAN or LIGHT BLUE {ESC}[36m**  
**/CYAN or /LIGHT BLUE {ESC}[46m**

The CYAN and LIGHT BLUE commands set the foreground color to cyan, or light blue. /CYAN and /LIGHT BLUE set the background color to cyan, or light blue. The CYAN and the LIGHT BLUE commands, as well as the /CYAN and the /LIGHT BLUE commands, are identical.

Example: Display black text on a light blue background.

```
BLACK
/CYAN
DISPLAY "Black on cyan, or light blue"
```

**GREEN {ESC}[32m**  
**/GREEN {ESC}[42m**

The GREEN command sets a foreground color to green. /GREEN sets a background color to green.

Example: Display green text on a white background.

```
GREEN
/WHITE
DISPLAY "Green on white"
```

**MAGENTA or PURPLE {ESC}[35m**  
**/MAGENTA or /PURPLE {ESC}[45m**

The MAGENTA and PURPLE commands set the foreground color to magenta, or purple. /MAGENTA and /PURPLE set the background color to magenta. The MAGENTA and PURPLE commands, as well as the /MAGENTA and /PURPLE commands, are identical.

**RED {ESC}[31m**  
**/RED {ESC}[41m**

The RED command sets the foreground color to red. /RED sets the background color to red.

**WHITE {ESC}[37m**  
**/WHITE {ESC}[47m**

The WHITE command sets the foreground color to white. /WHITE sets the background color to white.

**YELLOW {ESC}[33m**  
**/YELLOW {ESC}[43m**

The YELLOW command sets the foreground color to yellow. /YELLOW sets the background color to yellow.

### Attributes for Monochrome OITs Only

All of the following commands are valid on monochrome OITs and on units with the MONOCHROME option saved on the configuration menu. With all of the following intensities, you use the foreground setting (such as BRIGHT or DARK) to specify the intensity for the text or graphics.

You use the background setting (such as /DIM or /NORMAL) to specify the intensity for a region.

The RESET ATTRIBUTES command resets all character attributes to the default intensities and no underlining.

**BRIGHT {ESC}[33m**  
**/BRIGHT {ESC}[43m**

The BRIGHT command sets the foreground intensity level to higher than normal. /BRIGHT sets the background intensity level to higher than normal.

Example: Display information with normal text and the warning in bright text.

```
NORMAL
MOVE TO 10, 1
DISPLAY "Bin 1 OK"
BRIGHT
MOVE TO 12, 1
DISPLAY "CHECK BIN 2"
NORMAL
MOVE TO 14, 1
DISPLAY "Bin 3 OK"
```

**DIM {ESC}[31m**  
**/DIM {ESC}[41m**

The DIM command sets the foreground intensity level lower than normal. /DIM sets the background intensity level to lower than normal.

Example: Display dim text over a dark background and bright text over a dim background.

```
MOVE TO 10, 10
DIM
/DARK
DISPLAY "Staging area "
BRIGHT
/DIM
DISPLAY "Overloaded"
RESET ATTRIBUTES
```

**DARK {ESC}[30m**  
**/DARK {ESC}[40m**

The DARK command sets the foreground intensity level to dark. /DARK sets the background intensity level to dark.

**NORMAL {ESC}[32m**  
**/NORMAL {ESC}[42m**

The NORMAL command sets the foreground intensity level to normal. /NORMAL sets the background intensity level to normal.

Example: Display normal text, bright text, and return to normal again.

```
NORMAL
MOVE TO 10, 20
DISPLAY "Step 1 Complete"
BRIGHT
MOVE TO 12, 20
DISPLAY "Step 2 In Process"
NORMAL
MOVE TO 14, 20
DISPLAY "Step 3 Scheduled, Not Done"
```

**UNDERLINE {ESC}[36m**  
**BRIGHT UNDERLINE {ESC}[>37r**  
**DIM UNDERLINE {ESC}[35m**

The UNDERLINE command sets the foreground intensity level to normal and underlines the text. The BRIGHT UNDERLINE command sets the foreground intensity level higher than normal and underlines the text. The DIM UNDERLINE command sets the foreground intensity level lower than normal and underlines the text.

The RESET ATTRIBUTES command resets all underlining modes as well as all character attributes to the default: normal size, normal color or intensity, no blink, and no reversed colors or intensities.

Example 1: Display a line of underlined text.

```
UNDERLINE
DISPLAY "Bin Full"
RESET ATTRIBUTES
```

Example 2: Display a message with one word underlined with a bright underline.

```
BRIGHT
DISPLAY "System 1 loading "
BRIGHT UNDERLINE
DISPLAY "NOW"
RESET ATTRIBUTES
```

## The ATTRIBUTE Command for all OITs

The ATTRIBUTE command allows you to specify character attribute settings that operate on both color and monochrome settings.

**ATTRIBUTES: nn, nn {ESC} nnn; nnn m**

**ATTRIBUTES: nn, nn, nn {ESC} nnn; nnn; nnn m**

The ATTRIBUTE command establishes two or three character attributes as the current character attribute mode or modes.

**nn** - specifies a character attribute mode number from the table given below.

Each OptiSCREEN character attribute command offers an identical ATTRIBUTE command; for example, the ATTRIBUTE: 12 command and the ALTERNATE command are identical. The ATTRIBUTE mode numbers and their paired character attribute commands are listed below:

Mode	Character Attribute Command
0	RESET ATTRIBUTES
1	BRIGHT
2	DIM
4	UNDERLINE
5	BLINK
7	REVERSE
10	EXIT SUPPLEMENTAL
11	SUPPLEMENTAL
12	ALTERNATE
13	EXIT ALTERNATE
14	BRIGHT and /DIM (sometimes called "shade")
15	DOUBLE WIDE
16	QUAD SIZE
17	EXIT QUAD SIZE
22	EXIT DOUBLE WIDE AND BLINK
30	BLACK or Hidden
31	RED or DIM
32	GREEN or NORMAL
33	YELLOW or BRIGHT
34	BLUE or UNDERLINE
35	MAGENTA or DIM UNDERLINE
36	LIGHT BLUE or UNDERLINE
37	WHITE or BRIGHT UNDERLINE
40	/BLACK or /Hidden
41	/RED or /DIM
42	/GREEN or /NORMAL
43	/YELLOW or /BRIGHT
44	/BLUE or /NORMAL
45	/MAGENTA or /DIM
46	/LIGHT BLUE or /NORMAL
47	/WHITE or /BRIGHT

**Example 1: Display white characters on a blue background.**

```
ATTRIBUTES: 37, 44
DISPLAY "This is white foreground on blue background"
```

Example 2: Display blue blinking characters on a white background.

```
ATTRIBUTES: 5, 34, 47
DISPLAY "Now the text is blue and blinking"
```

## Line Attribute Commands

Line attribute commands set the video attributes for a single line of text on the screen.

**DOUBLE SIZE {ESC}#7**  
**DOUBLE SIZE "text" {ESC}#9"text"{ETX}**

The DOUBLE SIZE line attribute command establishes double size as the current line attribute mode. Double size characters extend from the current cursor position up one line so that each double size character appears two character cells tall and one character cell wide. Since DOUBLE SIZE is a line attribute, only double size characters appear on a double size line. The DOUBLE SIZE command only affects a single line.

The RESET LINE ATTRIBUTES command resets the DOUBLE SIZE attribute as well as all line attributes to single height and single width characters.

**text** - specifies a line of text generated with double size characters. When you specify text, the system leaves the cursor at the end of the line.

Example 1: Display a single line of double-sized text.

```
MOVE TO 10, 35
DOUBLE SIZE
DISPLAY "ALPHA CORP."
MOVE TO 12, 36
DISPLAY "Distribution System"
```

Example 2: Display a single line of double-sized text.

```
MOVE TO 10, 20
DOUBLE SIZE "XYZ INC."
MOVE TO 12, 20
DISPLAY "Loader No. 1"
```

**DOUBLE WIDE LINE {ESC}#6**

This command establishes double-wide characters for an entire line of characters on the screen.

Example: Display a single line of double-wide text and a line of normal text.

```
MOVE TO 10, 20
DOUBLE WIDE LINE
DISPLAY "Sprayer Operating"
MOVE TO 15, 26
DISPLAY "Do not change setting"
```

## SINGLE SIZE LINE {ESC}#5

This command establishes an entire line of single-sized characters on the screen. An example of this command appears below under the RESET LINE ATTRIBUTES command.

## RESET LINE ATTRIBUTES {ESC}#0

This command resets all line attributes to the default operating mode with single height and single width characters.

Example: Display the words INPUT and OUTPUT with double wide characters. After each of the words, display location n with normal characters. Use the SINGLE SIZE LINE command to reset the first occurrence of double wide characters; use the RESET LINE ATTRIBUTES command to reset the second occurrence.

```
MOVE TO 5, 5
DOUBLE WIDE LINE
DISPLAY "INPUT "
SINGLE SIZE LINE
DISPLAY "location 1"
DOUBLE WIDE LINE
DISPLAY " OUTPUT "
RESET LINE ATTRIBUTES
DISPLAY "location 2"
```

## Clock and Date Commands

The clock and date commands specify whether or not the date and time appear at the bottom of the screen in the OptiSCREEN status line.

**DISABLE TIME {ESC}[?15I**

**ENABLE TIME {ESC}[?15h**

After you give the DISABLE TIME command, the system does not display the time at the bottom of the screen. To force the time to appear again, enter the ENABLE TIME command.

**DISABLE DATE {ESC}[?14I**

**ENABLE DATE {ESC}[?14h**

After you give the DISABLE DATE command, the system does not display the date at the bottom of the screen. To force the date to appear again, enter the ENABLE DATE command.

Example: Disable the date and time display from the bottom of the screen, display three screens in the body of the screen, and then force only the date to appear again at the bottom of the screen.

```
DISABLE DATE
DISABLE TIME
DISPLAY FILE 25
DISPLAY FILE 26
DISPLAY FILE 27
ENABLE DATE
```

## DISPLAY DATE HERE DISPLAY TIME HERE

These commands allow you to move the date display and the time display from the bottom right corner of the screen. The commands change the display position, not the character attributes or line attributes.

Example: Display the time and date in a new location on the screen.

```
MOVE TO 1, 1
DISPLAY "Time: "
DISPLAY TIME HERE
MOVE TO 1, 15
DISPLAY DATE HERE
END
```

## Display and File Display Commands

The display and file display commands are two of the most commonly used commands in the OptiSCREEN editor. With the DISPLAY command, you can generate text and graphics for your application. With the DISPLAY FILE command, you can “call” (or display) other OptiSCREEN files, file memory, or a directory of files.

### “text” text DISPLAY “text” text

These commands display a string of text that you specify.

**text** - represents the string that you want to display.

Text strings surrounded by quotes operate the same as the DISPLAY “text” command.

Example 1: Display a three word message.

```
“Message for Viewing”
```

Example 2: Display a five word message.

```
DISPLAY “This is a text message”
```

### DISPLAY FILE nn {ESC}[> nnn w

This command displays another screen file.

**nn** - specifies the name or number of the file that you want to display.

Example 1: Display the results of the command sequence stored in file 30.

```
DISPLAY FILE 30
```

Example 2: Display the results of the command sequence stored in file CHAMBER2.

```
DISPLAY FILE CHAMBER2
```

### DISPLAY FILE MEMORY {ESC}[>z

This file display command displays file memory at the screen.

### DISPLAY DIRECTORY {ESC}[dw

This display command displays the OptiSCREEN directory of file names.

Example: After you specify the DISPLAY DIRECTORY command in a file, the following kind of output appears in the specified location:

Name	Size	Type
App1	82	SCREEN Appl 1: Part 1
App2	243	SCREEN Appl 2: Part 2
App3	144	SCREEN Appl 3: Part 3

## Erasing and Editing Commands

The erasing and editing commands allow you to perform a number of operations that edit text and graphics which already appear on the screen: clear the screen or a portion of the screen, insert new text, or specify a scrolling region for text or graphics.

### Clearing the Screen

With the following commands, you can clear the whole screen or a portion of the screen, clear a line or a part of a line, or clear individual characters.

#### CLEAR SCREEN {ESC}[2J

This command moves the cursor to the home position at row 1 and column 1, clears the entire screen, and resets all attributes to normal. Examples of this command appear throughout this summary.

#### CLEAR SCREEN FROM CURSOR {ESC}[0J

This command clears the screen from the current cursor position to the end of the screen.

Example: Generate two lines of text, move to the middle of the first line, and delete the screen below and to the right of the cursor. The result is a line that reads Part only.

```
MOVE TO 10, 20
DISPLAY "Part one"
MOVE TO 11, 20
DISPLAY "Second section"
MOVE TO 10, 24
CLEAR SCREEN FROM CURSOR
```

## **CLEARSCREEN TO CURSOR {ESC}[1J**

This command clears the screen from the home position (at row 1 and column 1) to the current cursor position.

Example: Generate two lines of text, move to the middle of the second line, and delete the screen above and to the left of the cursor. The result is a line that reads two only.

```
MOVE TO 10, 20
DISPLAY "First part"
MOVE TO 11, 20
DISPLAY "Part two"
MOVE TO 11, 24
CLEAR SCREEN TO CURSOR
```

## **CLEAR LINE {ESC}[2K**

This command clears the contents of the entire line on which the cursor rests. This command erases the cursor although the cursor does not move.

Example: Generate a line of text, move to the middle of the line, and delete the entire line.

```
MOVE TO 10, 20
DISPLAY "First line"
MOVE TO 10, 25
CLEAR LINE
```

## **CLEARLINE FROM CURSOR {ESC}[0K**

This command clears the contents of the line from the current cursor position, including the character on which the cursor rests, to the end of the line. The cursor does not move.

Example: Generate a line of text, move to the middle of the line, and delete the line to the right of the cursor. The result is a line that reads Second only.

```
MOVE TO 10, 20
DISPLAY "Second line"
MOVE TO 10, 26
CLEAR LINE FROM CURSOR
```

## CLEARLINE TO CURSOR {ESC}[1K

This command clears the line from the beginning of the line to the current position of the cursor including the character on which the cursor rests. The cursor does not move.

Example: Generate a line of text, move to the middle of the line, and delete the line to the left of the cursor. The result is a line that reads test only.

```
MOVE TO 10, 20
DISPLAY "Third test"
MOVE TO 10, 25
CLEAR LINE TO CURSOR
```

## CLEARSTATUS LINE {ESC}[3J

This command clears the status line or status lines in the status region at the bottom of the screen. You can designate lines 22, 23, and 24 as status lines by using the Configuration Menu. Line 25 is always a status line.

## DELETE LINE {ESC}[M DELETE nn LINES {ESC}[nnn M

This command deletes one or more lines.

**nn** - specifies the number of lines for deletion. If you do not specify the number of lines, the command deletes the entire line on which the cursor rests. This command deletes the entire line on which the cursor rests and the following line or lines to delete a total of nn lines.

The cursor moves to the line following the deleted line or lines. The DELETE LINE command scrolls the existing text below the deleted line or lines up the screen and adds blank lines at the bottom of the screen above the status line.

Example: Generate five lines of text, then remove the first line of text and the last two lines of text leaving lines two and three displayed.

```
MOVE TO 10, 1
DISPLAY "Line One"
NEW LINE
DISPLAY "Line Two"
NEW LINE
DISPLAY "Line Three"
NEW LINE
DISPLAY "Line Four"
NEW LINE
DISPLAY "Line Five"
MOVE TO 10, 5
DELETE LINE
DOWN 2
DELETE 2 LINES
```

**ERASE BAR direction pp {ESC}[= ppp i**  
**ERASE BAR direction cc X pp {ESC}[= ccc; ppp i**

These commands erase a bar (as created for a bar graph) in the direction that you specify.

**direction** - specifies the direction for the erased bar graph as either UP, DOWN, RIGHT, or LEFT.

**pp** - specifies the number of pixels on which the cursor rests and above, below, to the right or to the left of the cursor used to erase the bar.

If you specify ERASE BAR UP or ERASE BAR DOWN, a single character cell appears 10 pixels "tall." The ERASE BAR UP and ERASE BAR DOWN commands erase the actual number of pixels that you specify for the bar graph.

If you specify ERASE BAR RIGHT or ERASE BAR LEFT, a single character cell appears 8 pixels "wide." The ERASE BAR RIGHT and ERASE BAR LEFT commands erase the actual number of pixels that you specify for the bar graph.

**cc** - specifies the number of whole columns on which the cursor rests and to the right or above the cursor erased for the bar.

If you specify ERASE BAR UP or ERASE BAR DOWN, cc represents the number of columns to the right of the cursor erased for the bar.

If you specify ERASE BAR RIGHT or ERASE BAR LEFT, cc represents the number of rows above the cursor erased for the bar.

If you do not specify the number of columns or rows with cc, the ERASE BAR command uses the column or row on which the cursor rests and erases a bar pp pixels tall or wide. Otherwise, the system erases a bar cc columns tall or wide and pp pixels wide or tall.

**Example 1:** Generate a block of Xs and then use the ERASE DOWN command to erase a single cell within the block.

```
MOVE TO 4, 2
DISPLAY "XXXXXX"
MOVE TO 5, 2
DISPLAY "XXXXXX"
MOVE TO 6, 2
DISPLAY "XXXXXX"
MOVE TO 7, 2
DISPLAY "XXXXXX"
MOVE TO 5, 3
ERASE DOWN 3
```

After this ERASE command, the block of Xs looks like this:

```
XXXXXX
X XXXX
XXXXXX
XXXXXX
```

**Example 2:** Continuing with the example started above, erase from the block a set of cells that are two cells wide and two cells tall.

```
MOVE TO 5, 5
ERASE DOWN 2 X 11
```

After this ERASE command, the block of Xs looks like this:

```
XXXXXX
X X X
XXX X
XXXXXX
```

**Example 3:** Generate a block of Xs and then erase an area three cells tall and one cell wide.

```
MOVE TO 5, 5
DISPLAY "XXXX"
MOVE TO 6, 5
DISPLAY "XXXX"
MOVE TO 7, 5
DISPLAY "XXXX"
MOVE TO 8, 5
DISPLAY "XXXX"
MOVE TO 9, 5
DISPLAY "XXXX"
MOVE TO 8, 6
ERASE UP 30
```

After this ERASE command, the block of Xs looks like this:

```
XXXX
X XX
X XX
X XX
XXXX
```

**Example 4:** Generate a block of Xs and then erase an area two cells wide and one cell tall within the block.

```
MOVE TO 5, 1
DISPLAY "XXXXXX"
MOVE TO 6, 1
DISPLAY "XXXXXX"
MOVE TO 7, 1
DISPLAY "XXXXXX"
MOVE TO 6, 2
ERASE RIGHT 16
```

After this ERASE command, the block of Xs looks like this:

```
XXXXX
X  XX
XXXXX
```

## DELETE CHARACTER {ESC}[P DELETE nn CHARACTERS {ESC}[ nnn P

This command deletes one or more characters.

**nn** - specifies the number of characters for deletion. If you do not specify the number of characters, the system deletes the character that the cursor covers. This command deletes the character that the cursor covers and the character or characters to the right of the cursor to delete a total of nn characters.

Any characters to the right of the deleted character or characters shift left and the cursor covers the character after the last deleted character.

**Example 1:** Enter a line of text, move to the middle of the line, and delete a single character and the space following the character. The result is a line that reads Test character.

```
MOVE TO 10, 20
DISPLAY "Test 1 character"
MOVE TO 10, 25
DELETE CHARACTER
DELETE CHARACTER
```

**Example 2:** Continuing with the line that reads Test character, delete the nine characters in the word character.

```
MOVE 10, 25
DELETE 9 CHARACTERS
```

## Inserting Text

The following commands allow you to insert text or graphics into already existing text or graphics.

### INSERT LINE {ESC}[L INSERT nn LINES {ESC}[ nnn L

This command inserts one or more lines into a screen.

**nn** - specifies the number of lines for insertion. If you do not specify the number of lines, the command inserts a single line at the line on which the cursor rests. Otherwise, this command inserts nn lines at the line on which the cursor rests and below the cursor.

After the insertion, the cursor rests on the single inserted line or the first inserted line of the inserted line or lines. The INSERT command scrolls the existing text toward the bottom of the screen.

Example 1: Insert a single line and add text into the middle of several other lines of text.

```
MOVE TO 5, 1
DISPLAY "Line one"
NEW LINE
DISPLAY "Line two"
NEW LINE
DISPLAY "Line three"
NEW LINE
DISPLAY "Line four"
NEW LINE
DISPLAY "Line five"
MOVE TO 7, 1
INSERT LINE
DISPLAY "First insertion"
```

Example 2: Continuing with the example started above, insert two lines above the last line of existing text, and fill both inserted lines with text.

```
MOVE TO 10, 1
INSERT 2 LINES
DISPLAY "Second insertion"
NEW LINE
DISPLAY "Third insertion"
```

After the two sets of insertions, the results look like this:

```
Line one
Line two
First insertion
Line three
Line four
Second insertion
Third insertion
Line five
```

**START INSERT {ESC}[4h**  
**STOP INSERT {ESC}[4I**

The **START INSERT** command begins the insertion mode so that you can insert characters into text that already appears on the screen. As you send characters, text to the right of the cursor shifts right; characters in column 80 shift off the screen and do not wrap.

The **STOP INSERT** command ends the insertion mode.

Example: Display three lines of text and then insert the text from another file “in front” of the three lines.

```
MOVE TO 10, 1
DISPLAY "First Line"
MOVE TO 11, 1
DISPLAY "Second Line"
MOVE TO 12, 1
DISPLAY "Third Line"
MOVE TO 11, 1
START INSERT
DISPLAY FILE 100
STOP INSERT
```

Assume that file 100 contains the following commands.

```
DISPLAY "Insertion 1 "
NEW LINE
DISPLAY "Insertion 2 "
INDEX
DISPLAY "Insertion 3 "
NEW LINE
DISPLAY "Insertion 4 "
```

The resulting file appears as shown below.

```
First Line
Insertion 1 Second Line
Insertion 2 Third Line
Insertion 3
Insertion 4
```

## Scrolling

The scrolling commands allow you to specify a region for scrolling through text or graphics.

**SCROLL LINES nn TO pp {ESC}[ nnn; ppp r**

The SCROLL LINES command causes a specified area of the screen to scroll up.

**nn** - specifies the top line of the scrolling area.

**pp** - specifies the bottom line of the scrolling area.

After you specify text or graphics to appear on the scrolling lines, the text or graphics shift up one row at a time. Screen data outside of the scrolling lines does not move or change, nor does the cursor position change as the text or graphics scroll through the lines.

Example: Define a scrolling area and delimit it with a line of text both before and after. Display a file directory in the scrolling area and the word Done after you've completed the display.

```
MOVE TO 10, 1
DISPLAY "--- Top ---"
SCROLL LINES 11 TO 13
MOVE TO 14, 1
DISPLAY "--- Bottom --"
MOVE TO 11, 1
DISPLAY DIRECTORY
MOVE TO 15, 1
DISPLAY "- Done -"
```

### SCROLL direction rr X cc {ESC}[= rrr; ccc q

These scrolling commands specify the area and the direction for scrolling text and graphics.

**direction** - specifies the direction for scrolling text and graphics as either UP, DOWN, RIGHT, or LEFT.

**rr** - represents the number of rows for the height of the scrolling region. Specify rr as greater than or equal to 2 and less than or equal to 24.

**cc** - represents the number of columns for the width of the scrolling region. Specify cc as greater than or equal to 2 and less than or equal to 80.

The system uses the current cursor position to determine the location of the scrolling region on the screen. After you specify text or graphics to appear in the scrolling region, the text or graphics shift one character or one row at a time in the indicated direction (up, down, left, or right).

Screen data outside of the scrolling region does not move or change, nor does the cursor position change as the text or graphics scroll through the region.

When you specify SCROLL LEFT, the system positions the cursor in the lower right corner of the scrolling region. When you specify SCROLL RIGHT, the system positions the cursor in the lower left corner of the scrolling region. The SCROLL LEFT and SCROLL RIGHT commands are helpful for presenting trend graphs.

When you specify SCROLL UP, the system positions the cursor in the lower left corner of the scrolling region. When you specify SCROLL DOWN, the system positions the cursor in the upper left corner of the scrolling region. The SCROLL UP and SCROLL DOWN commands are helpful for presenting text messages.

## Graphics Commands

The graphics commands draw boxes, change the video attributes for boxed regions of the screen, and draw bar graphs:

- The BOX command draws a box around text or graphics.
- The EMPTY BOX command draws a box and erases any text or graphics that appear inside.
- The FILL BOX command draws a box and fills it with a single character.
- The BOX ATTRIBUTES command defines the character attributes (such as color) for a boxed region; this is helpful for defining a color for a region.

Each of these “box” commands is described before the bar graph commands are described.

### Generating Boxes and Boxed Regions

The following commands draw boxes from the lower left-hand corner of the box or define a boxed region.

**BOX rr X cc {ESC}[= rrr, ccc d**

This command creates an outlined box.

**rr** - specifies the number of rows up from the cursor that the box extends.

**cc** - specifies the number of columns to the right from the cursor that the box extends.

The system draws boxes from the lower left-hand corner of the box. Legal cursor positions fall between rows 1 to 25 and between columns 1 to 80. If a box exceeds a legal cursor position, the box wraps around to the opposite side or opposite end of the screen. The lines used for the box outline are two character dots wide and two scan lines high. Both the row specification **rr** and the column specification **cc** must be greater than or equal to 2. The **BOX** command does not change the existing text within a box.

**Example 1:** Draw two boxes surrounding text in the center of the screen. The first box outlines the text as closely as possible. The second box borders the entire screen.

```
MOVE TO 11, 36
DISPLAY "GE Fanuc"
MOVE TO 12, 35
BOX 3 x 10
BLUE
MOVE TO 24, 1
BOX 24 x 80
```

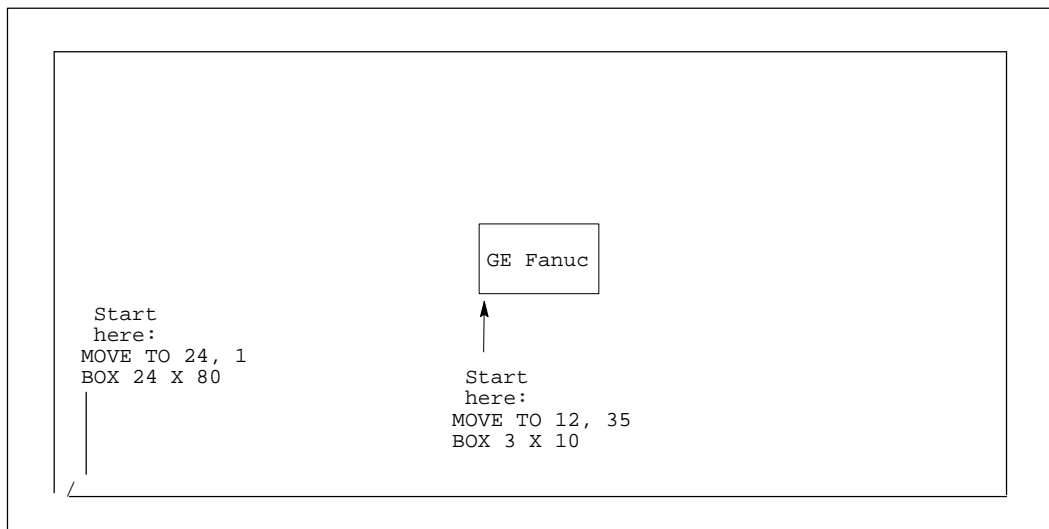

Example 2: Character attributes affect both text and boxes. For example, if you create a box after a DOUBLE WIDE command, the box covers twice as many character cells as the command states since the system doubles the box width. The following commands draw two double wide text messages surrounded by boxes. The first box appears as a double wide box and the second box appears with normal character attributes.

```
DOUBLE WIDE
MOVE TO 10, 20
DISPLAY "BOX 1"
MOVE TO 11, 18
BOX 3 x 7
MOVE TO 20, 20
DISPLAY "BOX 2"
EXIT DOUBLE WIDE AND BLINK
MOVE TO 21, 19
BOX 3 x 11
```

### EMPTY BOX *rr* X *cc* {ESC}[= *rrr*; *ccc* e

This command creates an empty box. This command erases any text or graphics that previously appeared in the boxed region.

*rr* - specifies the number of rows up from the cursor that the box extends.

*cc* - specifies the number of columns to the right from the cursor that the box extends.

The system draws boxes from the lower left-hand corner of the box. Legal cursor positions fall between rows 1 to 25 and between columns 1 to 80. If a box exceeds a legal cursor position, the box wraps around to the opposite side or opposite end of the screen. The lines used for the box outline are two character dots wide and two scan lines high. Both the row specification *rr* and the column specification *cc* must be greater than or equal to 2.

Example: Create an empty box 12 rows tall by 40 columns wide.

```
MOVE TO 20, 20
EMPTY BOX 12 X 40
```

### FILL BOX *rr* X *cc* WITH "a" {ESC}[*rrr*; *ccc* b a

This command creates a box and fills it with a single character.

*rr* - specifies the number of rows up from the cursor that the box extends.

*cc* - specifies the number of columns to the right from the cursor that the box extends.

*a* - specifies the single "fill character" value that fills the boxed area. The fill character uses the current foreground and background character attribute settings. If you specify the fill character as a space (a non-printing character), this command fills the region with the color or setting currently specified by the background attribute.

The system draws boxes from the lower left-hand corner of the box. Legal cursor positions fall between rows 1 to 25 and between columns 1 to 80. If a box exceeds a legal cursor position, the box wraps around to the opposite side or opposite end of the screen. The lines used for the box outline are two character dots wide and two scan lines high. Both the row specification *rr* and the column specification *cc* must be greater than or equal to 2.

Example: Fill a box 12 rows by 40 columns with the letter X.

```
MOVE TO 15, 5
FILL BOX 12 X 40 WITH "X"
```

## **BOX ATTRIBUTES *rr X cc* {ESC}[= *rrr*; *ccc a***

This command applies the currently defined character attributes to a boxed region.

***rr*** - specifies the number of rows up from the cursor that the box extends.

***cc*** - specifies the number of columns to the right from the cursor that the box extends.

The system determines box attribute regions from the lower left-hand corner of the box. Legal cursor positions fall between rows 1 to 25 and between columns 1 to 80. If a box exceeds a legal cursor position, the box wraps around to the opposite side or opposite end of the screen. The lines used for the box outline are two character dots wide and two scan lines high. Both the row specification *rr* and the column specification *cc* must be greater than or equal to 2.

This command does not erase or rewrite any text or graphics that already exist in the box attribute region; it only changes the character attributes for the text or graphics in the region. This command is useful for defining and changing the colors or intensities for text on a screen without rewriting the text after the change.

Example: Define a line of text to read Blower off ON. Then define two sets of box attribute regions. The first box attribute region displays the word off with the default color and the word ON in black so that it is hidden. The second box attribute region displays the word off in black so that it is hidden and the word ON in red on a yellow background so that it is highlighted. The second box region includes a colored box around the word ON to highlight it even more.

Use the STEP editor function to move through the file and see how the two boxed attribute regions work.

```
'Blower off/on text
MOVE TO 10, 10
DOUBLE WIDE
DISPLAY "Blower off ON"
MOVE TO 11, 32
BOX 3 x 4
'
'Box attributes: Blower off normal
MOVE TO 10, 24
GREEN
BOX ATTRIBUTES 1 x 3
MOVE TO 11, 32
BLACK
/BLACK
BOX ATTRIBUTES 3 x 4
'
'Box attributes: Blower ON highlighted
MOVE TO 10, 24
BLACK
BOX ATTRIBUTES 1 X 3
MOVE TO 11, 32
RED
/YELLOW
BOX ATTRIBUTES 3 x 4
```

## Drawing Bar Graphs

The following commands draw horizontal or vertical bar graphs. However, the new VIEW GRAPH commands can generate the same graphs more easily; we recommend that new applications use the GRAPH or DRAW BAR command.

### **HORIZONTAL BAR GRAPH nn, ff, mm {ESC}[= nnn; fff; mmm h**

This command makes a horizontal bar graph that flows toward the right-hand edge of the screen.

**nn** - represents the number of whole cells for the graphed item in the bar; nn must be expressed as an integer to represent whole character cells.

**ff** - represents the percentage of a single cell for the bar; ff must be expressed as an integer from 0 to 99.

**mm** - represents the maximum number of cells for the bar.

When you invoke this command, it generates a bar of whole and fractional cells specified by nn and ff. The command erases any previous bar. The bars use the current foreground and background character attributes.

A single character cell appears 8 pixels "wide." Assuming a full 80 columns for a bar, this results in as many as 640 pixel-formed bars (8 \* 80) for a bar graph.

Example 1: Temperatures fall between 0 and 100 degrees. Generate a horizontal bar graph that uses a maximum of 10 cells. Show a temperature of 43.5 degrees.

1. Determine the range of the variable to be graphed.

$$\text{Range} = \text{Maximum} - \text{Minimum}$$

$$\text{Range} = 100 - 0$$

$$\text{Range} = 100$$

2. Determine the maximum number of character cells for the graph.

$$\text{mm} = 10$$

3. Decide the scaled actual value for the graph.

$$\text{Scaled value} = \text{Graph amount} * (\text{mm} / \text{Range})$$

$$\text{Scaled value} = 43.5 * (10 / 100)$$

$$\text{Scaled value} = 4.35$$

4. Determine the number of whole character cells for the graph.

$$\text{nn} = \text{INT} (\text{Scaled value})$$

$$\text{nn} = \text{INT} (4.35)$$

$$\text{nn} = 4$$

5. Determine the percentage of the remaining character to be graphed.

$$\text{ff} = (\text{Scaled value} - \text{nn}) * 100$$

$$\text{ff} = (4.35 - 4) * 100$$

$$\text{ff} = 35$$

The resulting bar graph command:

```
HORIZONTAL BAR GRAPH 4, 35, 10
```

Example 2: The count of an inventory item falls between -5 and 50. Generate a horizontal bar graph that uses a maximum of 12 cells. Show a level of 32 items.

1. Determine the range of the variable to be graphed.

$$\text{Range} = \text{Maximum} - \text{Minimum} = 50 - (-5) = 55$$

2. Determine the maximum number of character cells for the graph.

$$\text{mm} = 12$$

3. Decide the scaled actual value for the graph.

$$\text{Scaled value} = \text{Graph amount} * (\text{mm} / \text{Range}) = 32 * (12 / 55) = 6.98$$

4. Determine the number of whole character cells for the graph.

$$\text{nn} = \text{INT} (\text{Scaled value}) = \text{INT} (6.98) = 6$$

5. Determine the percentage of the remaining character to be graphed.

$$\text{ff} = (\text{Scaled value} - \text{nn}) * 100 = (6.98 - 6) * 100 = 98$$

The resulting bar graph command:

```
HORIZONTAL BAR GRAPH 6, 98, 12
```

## VERTICALBAR GRAPH nn, ff, mm {ESC}[= nnn; fff; mmm v

This command makes a vertical bar graph that reaches up toward the top of the screen.

**nn** - represents the number of whole cells for the graphed item in the bar; nn must be expressed as an integer to represent whole character cells.

**ff** - represents the percentage of a single cell for the bar; ff must be expressed as an integer from 0 to 99.

**mm** - represents the maximum number of cells for the bar.

When you invoke this command, it generates a bar of whole and fractional cells specified by nn and ff. The command erases any previous bar. The bars use the current foreground and background character attributes.

A single character cell appears 10 pixels "tall." Assuming a full 24 rows for a bar, this results in as many as 240 pixel-formed bars (10 \* 24) for a bar graph.

Example 1: A machine can process from 0 to 1000 objects per hour. Generate a vertical bar graph that uses a maximum of 10 cells. Show 884 objects on the graph.

1. Determine the range of the variable to be graphed.

$$\text{Range} = \text{Maximum} - \text{Minimum}$$

$$\text{Range} = 1000 - 0$$

$$\text{Range} = 1000$$

2. Determine the maximum number of character cells for the graph.

$$\text{mm} = 10$$

3. Decide the scaled actual value for the graph.

$$\text{Scaled value} = \text{Graph amount} * (\text{mm} / \text{Range})$$

$$\text{Scaled value} = 884 * (10 / 1000)$$

$$\text{Scaled value} = 8.84$$

4. Determine the number of whole character cells for the graph.

$$\text{nn} = \text{INT} (\text{Scaled value})$$

$$\text{nn} = \text{INT} (8.84)$$

$$\text{nn} = 8$$

5. Determine the percentage of the remaining character to be graphed.

$$\text{ff} = (\text{Scaled value} - \text{nn}) * 100$$

$$\text{ff} = (8.84 - 8) * 100$$

$$\text{ff} = 84$$

The resulting bar graph command:

```
VERTICAL BAR GRAPH 8, 84, 10
```

Example 2: Fluid levels must be maintained between 10 and 50 gallons. Generate a vertical bar graph that uses a maximum of 8 cells. Show a level of 18.5 gallons.

1. Determine the range of the variable to be graphed.

$$\text{Range} = \text{Maximum} - \text{Minimum} = 50 - 10 = 40$$

2. Determine the maximum number of character cells for the graph.

$$\text{mm} = 8$$

3. Decide the scaled actual value for the graph.

$$\text{Scaled value} = \text{Graph amount} * (\text{mm} / \text{Range}) = 18.5 * (8 / 40) = 3.7$$

4. Determine the number of whole character cells for the graph.

$$\text{nn} = \text{INT}(\text{Scaled value}) = \text{INT}(3.7) = 3$$

5. Determine the percentage of the remaining character to be graphed.

$$\text{ff} = (\text{Scaled value} - \text{nn}) * 100 = (3.7 - 3) * 100 = 70$$

The resulting bar graph command:

```
VERTICAL BAR GRAPH 3, 70, 8
```

**DRAW BAR direction pp {ESC}[= ppp i**  
**DRAW BAR direction cc X pp {ESC}[= ccc; ppp i**

These commands draw a bar graph with the bar extending in the direction that you specify.

**direction** - specifies the direction for the bar graph as either UP, DOWN, RIGHT, or LEFT.

**pp** - specifies the number of pixels on which the cursor rests and above, below, to the right or to the left of the cursor used to form the bar.

If you specify DRAW BAR UP or DRAW BAR DOWN, a single character cell appears 10 pixels "tall." The DRAW BAR UP and DRAW BAR DOWN commands use the actual number of pixels that you specify for the bar graph.

If you specify DRAW BAR RIGHT or DRAW BAR LEFT, a single character cell appears 8 pixels "wide." The DRAW BAR RIGHT and DRAW BAR LEFT commands use the actual number of pixels that you specify for the bar graph.

**cc** - specifies the number of whole columns on which the cursor rests and to the right or above the cursor used for the bar.

If you specify DRAW BAR UP or DRAW BAR DOWN, cc represents the number of columns to the right of the cursor for the bar.

If you specify DRAW BAR RIGHT or DRAW BAR LEFT, cc represents the number of rows above the cursor for the bar.

---

If you do not specify the number of columns or rows with `cc`, the `DRAW BAR` command uses the column or row on which the cursor rests and makes the bar `pp` pixels tall or wide. Otherwise, the bar appears `cc` columns tall or wide and `pp` pixels wide or tall.

Example 1: Draw a bar 71 row pixels tall and 1 column wide that extends down toward the bottom of the screen.

```
MOVE TO 5, 10
DRAW BAR DOWN 71
```

Example 2: Draw a bar 63 column pixels wide and 1 row tall that extends left across the screen.

```
MOVE TO 12, 40
DRAW BAR LEFT 63
```

Example 3: Draw a bar 17 column pixels wide and 1 row tall that extends toward the right edge of the screen.

```
MOVE TO 6, 5
DRAW BAR RIGHT 17
```

Example 4: Draw a bar 22 column pixels wide and 4 rows tall that extends toward the right edge of the screen.

```
MOVE TO 11, 5
DRAW BAR RIGHT 4 X 22
```

Example 5: Draw a bar 21 row pixels tall and 1 column wide that extends up toward the top of the screen.

```
MOVE TO 20, 30
DRAW BAR UP 21
```

Example 6: Draw a bar 27 row pixels tall and 4 columns wide that extends up toward the top of the screen.

```
MOVE TO 20, 34
DRAW BAR UP 4 X 27
```

## Programmable Keyboard and Function Key Commands

These commands allow you to set and use the programmable keyboard capabilities of an OIT. The LOAD FUNCTION KEY command sets and uses the function key capabilities for a OIT.

### Selecting the Programmable Keyboard

To program the keyboard, you must specify “5 PROGRAMMABLE” at the KEY CODES line of the Configuration Menu. To specify the programmable keyboard, perform the following steps:

1. Return to the Main Menu. (You can gain access to the Main Menu by pressing the MAIN [F1] function key from the OptiSCREEN editor).
2. From the main menu, enter the Configuration Menu by pressing the [F7 CONFIG] function key.
3. In the Configuration Menu, use the [Up Arrow] and [Down Arrow] cursor control keys to move to the KEYBOARD line of the menu.
4. On the KEYBOARD line, press the [Spacebar] repeatedly until the option 5 PROGRAMMABLE appears.
5. To save this configuration, press the SAVE [F5] function key.

After performing these steps you can set and use the programmable keyboard capabilities on your OIT.

### Programmable Keyboard Programming

The 34-position built-in keyboard and the 65-position sealed membrane keyboard are programmable. They can be programmed in either of two ways. The keys can be loaded individually through the LOAD KEY command or they can all be loaded together with one of the internal key tables with the LOAD KEY TABLE command. The internal key table options are Terminal, BASIC, and QWERTY. The character assignments of these key tables are shown in Chapter 1.

Any of the 94 key positions can be programmed as a function key using the LOAD FUNCTION KEY command. Each function key can be programmed to generate a sequence of up to 16 ASCII characters. Not more than 16 keys can become function keys.

On a cold start, the key table is initialized at the same time that the default configuration is loaded. The default and user-defined key values are retained in non-volatile memory.

The programmable keyboard and Function Key commands are described below.

#### **CLEARKEY TABLE {ESC}]>98r**

This programmable keyboard command eliminates any previous key table specifications and makes all key values null.

## DEFAULT KEY TABLE {ESC}[>99r

This programmable keyboard command sets the keys to the default key table. When displayed using the DISPLAY KEY TABLE command the default key table appears on the screen as shown below.

A 41	B 42	C 43	D 44	E 45	F 46	G 47	H 48	I 49	J 4A
K 4B	L 4C	M 4D	N 4E	O 4F	P 50	Q 51	R 52	S 53	T 54
U 55	V 56	W 57	X 58	Y 59	Z 5A	[ 5B	\ 5C	] 5D	^ 5E
_ 5F	' 60	a 61	b 62	c 63	d 64	e 65	f 66	g 67	h 68
i 69	j 6A	k 6B	l 6C	m 6D	n 6E	o 6F	p 70	q 71	r 72
s 73	t 74	u 75	v 76	w 77	x 78	y 79	z 7A	{ 7B	 7C

## DISPLAY KEY TABLE {ESC}{>97r

This command displays the contents, or individual key specifications, of the first 60 keys of the current key table specification. Example: After you specify the following sequence of commands, the default key table, shown above, appears on the screen.

```
CLEAR SCREEN
DEFAULT KEY TABLE
DISPLAY KEY TABLE
```

The position numbers of the keys displayed on the screen are shown below.

1	2	3	4	5	6	7	8	9	10
11	12	13	14	15	16	17	18	19	20
21	22	23	24	25	26	27	28	29	30
31	32	33	34	35	36	37	38	39	40
41	42	43	44	45	46	47	48	49	50
51	52	53	54	55	56	57	58	59	60

An additional example of the DISPLAY KEY TABLE command appears under the LOAD KEY command, described next.

### LOAD KEY nn WITH vvv {ESC} nnn; k r

This programmable keyboard command loads a specific key with a value that you specify. To use the command, specify the key position as a number between 1 and 94, as shown in the figures below:

The following diagrams show the key position numbers associated with the keyboards which can be programmed.

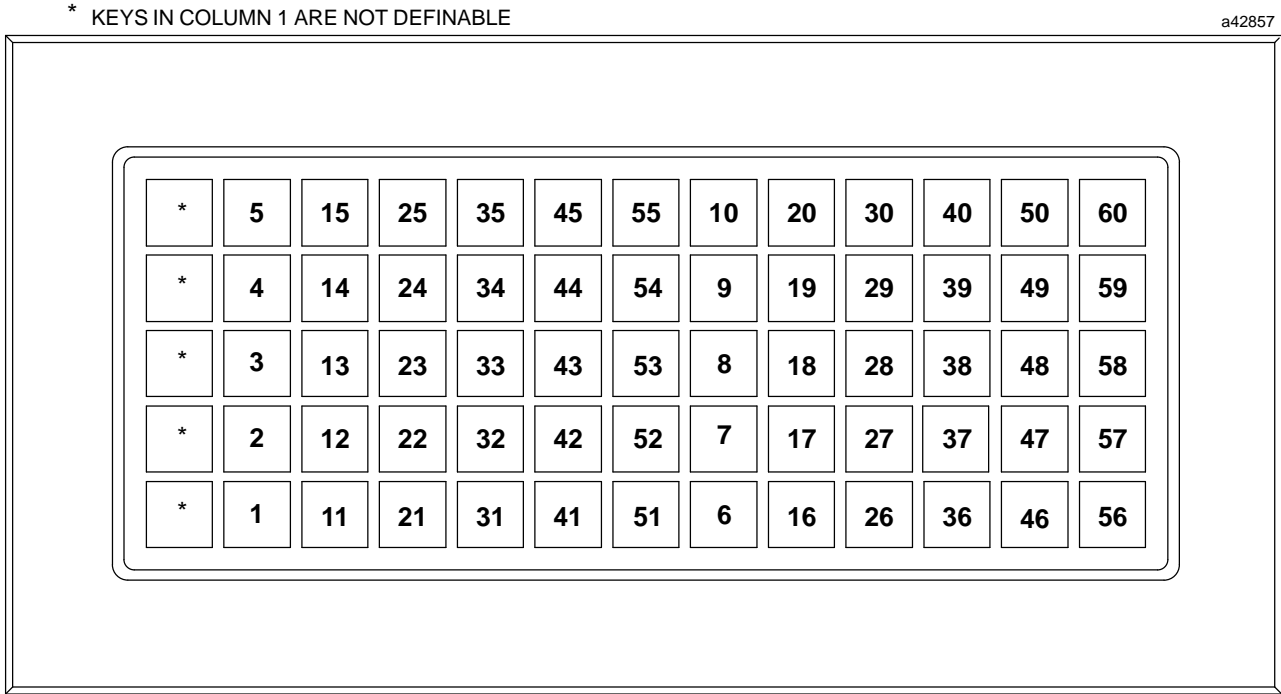
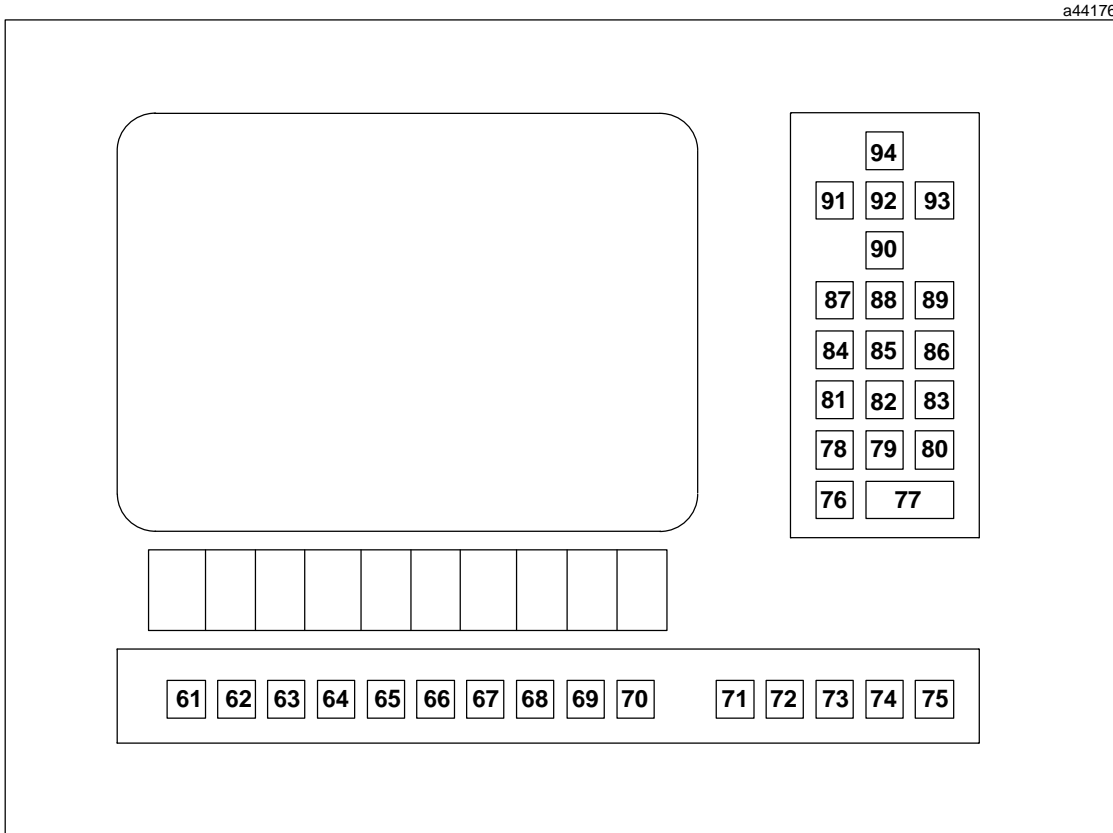

Figure 5-1. Key Location Numbers for the 65-Position Sealed Membrane Keyboard



**Figure 5-2. Key Location Numbers for the 34-Position Built-In Keyboard**

Specify the value of the key to be programmed as a single ASCII character vvv. The capital letters A through Z are indicated by the ASCII numbers 65 through 90, and the lower case letters a through z are indicated by the ASCII numbers 97 through 122.

Key Value:	Output When Activated:
0 to 31	Standard ASCII non-displayable codes*
32 to 127	Standard ASCII displayable codes*
128 to 143	Function key codes F1 to F16
144 to 153	Control-1 to Control-9
154 to 169	Not used
170 to 171	IBM special key codes
172 to 175	Not used
176 to 177	IBM special key codes (Ins, End)
178	Cursor Down
179	IBM special key code (Page Down)
180	Cursor Left
181	Not used
182 to 184	Cursor Right, Home, Up key codes
185	IBM special key code (Page Up)
186 to 191	Not used
192 to 204	IBM special key codes
205 to 254	Not used
255	No keystroke code

\* Refer to Appendix B for ASCII Codes.

The key tables contain unshifted, non-control values for 94 available key positions. If used with the 65-position and/or 34-position membrane keyboards, all keys except the Reset, Break, Control, Repeat, and Shift keys become user-definable. The Shift and Control keys are inactive. This enables you to define the ASCII code generated by any of the 94 available key positions.

Example: Clear the programmable keyboard specification and load key number 1, with the letter A.

```
CLEAR SCREEN
CLEAR KEY TABLE
LOAD KEY 1 WITH 65
DISPLAY KEY TABLE
```

### **LOADKEY TABLE nn {ESC}]>10n r**

This programmable keyboard command loads a predefined key table. Specify key table nn as a number (1, 2, or 4 to correspond with Terminal, BASIC, and QWERTY keyboard layouts).

Example: Load key table 1 and display it to determine its contents.

```
CLEAR SCREEN
CLEAR KEY TABLE
LOAD KEY TABLE 1
DISPLAY KEY TABLE
```

### **LOAD FUNCTION KEY nn WITH “text” {ESC} nnn t text {ETX}**

This function key command loads function key nn with a value (text). Specify nn as a function key number between 1 and 16, inclusive.

Example: Load function key [F12] with the RUN command.

```
LOAD FUNCTION KEY 12 WITH "RUN"
```

### **FUNCTION KEY nn PERFORMS file**

This function key command loads a function key so that it executes an OptiSCREEN file when pressed. Specify nn as a function key number between 1 and 16, inclusive. Specify file as a valid OptiSCREEN file name.

Example: Load function key [F13] so that it calls the OptiSCREEN file named MYSTART when pressed.

```
FUNCTION KEY 13 PERFORMS MYSTART
```

### **KEY mmm PERFORMS file**

This key command loads any key so that it executes an OptiSCREEN file when pressed. Specify mmm as the decimal value of the key. Specify file as a valid OptiSCREEN file name.

Example: Load the key [Z] so that it calls the OptiSCREEN file named MENU2 when pressed.

```
KEY 90 PERFORMS MENU2
```

## Data Transmissions and Port Control Commands

These commands control data transmissions and output from the serial port or ports associated with the OIT.

### PRINT SCREEN TO PORT *n*

### PRINT SCREEN TO PORT *n*, GRAPHIC TYPE *g* {ESC}[ *nnn*; *ggg* *S*

These commands send the current screen to a printer.

Specify *n* as 1 for port 1, 2 for port 2, or 3 for port 3.

Specify *g* as a number between 0 and 6, as described below:

<b><i>g</i></b>	<b>Printer</b>	<b>Approximate size of image</b>
0	Specified in Configuration	Depends on printer
1	Generic ASCII	Depends on printer
2	Citoh-3500	3" tall by 6" wide
3	Citoh-3500	7" tall by 11" wide
4	Citoh-3500	9" tall by 6" wide*
5	Proprinter	3" tall by 5" wide
6	Proprinter	9" tall by 6" wide*

\* Image rotated counterclockwise 90 degrees.

If you do not specify GRAPHIC TYPE *g*, the system generates a generic ASCII file.

Example: Send the current screen to port 1 for printing on a Citoh-3500 printer 7" tall by 11" wide.

```
PRINT SCREEN TO PORT 1, GRAPHIC TYPE 2
```

### TRANSMIT DIRECTORY VIA position PORT

This command transmits a directory of the entire memory contents to the output device at either the primary or secondary port. Specify the port position as either PRIMARY or SECONDARY, depending on where you want the directory sent. The directory groups files by type.

Example:

```
TRANSMIT DIRECTORY VIA PRIMARY PORT
```

### TRANSMIT FILE *fname* VIA position PORT

This command transmits a single file to the output device at either the primary or secondary port. Specify *fname* as the file for display. Specify the port position as either PRIMARY or SECONDARY, depending on where you want the directory sent.

Example:

```
TRANSMIT FILE NEW_DATA VIA SECONDARY PORT
```

## VIEW Commands

(For OITs with OptiBASIC only.) VIEW commands give you powerful and easy-to-use graphic animation capabilities. These commands automatically animate data, allowing you to generate a changing graph or graphic display with a single command, as well as update numeric data displayed on the screen.

The VIEW commands (GRAPH item, VIEW item, and USE FORMAT) are not available with the standard OITs, but are available with OITs with OptiBASIC.

**GRAPH item direction cells SCALE min TO max {ESC} < E “name”; pixel; nnn; ppp E**  
**GRAPH item TITLE “string” direction cells SCALE min TO max {ESC} < F “name”;**  
**title{ETX}; nnn; ppp F**

**GRAPH item USING “format” direction cells SCALE min TO max {ESC} < G**  
**“name”; string{ETX}; nnn; ppp G**

**GRAPH item USING “format” TITLE “string” direction cells SCALE min TO max**  
**{ESC} “name”; string{ETX}; title{ETX}; pixel; nnn; ppp H**

These commands generate a bar graph that extends up, down, right, or left across the screen. Optionally, you can label these bar graphs with a title and the graphed value. The system determines the position of bar graphs (and any titles or numeric value labels) from the lower left-hand corner of the bar and any titles or labels.

**item** - specifies the name of the data element that you want to graph. Item is often an element such TEMP, GALLONS, LEVEL, or AMOUNT.

**direction** - specifies the direction for the graph as either UP, DOWN, RIGHT, or LEFT.

If you specify direction as UP, the bar graph extends up toward the top of the screen. Any title or numeric value label for the bar appears below the bar itself. The bar appears as wide as any title or numeric value that you specify. The cursor position determines the location for any title or numeric value label that appears below the bar.

If you specify direction as DOWN, the bar graph falls down toward the bottom of the screen. Any title or numeric value label for the bar appears above the bar itself. The bar appears as wide as any title or numeric value that you specify. The cursor position determines the lower left-hand corner of the bar.

If you specify direction as RIGHT, the bar graph flows toward the right-hand edge of the screen. Any title or numeric value label for the bar appears to the left of the bar itself. The cursor position determines the location for any title or numeric value label that appears to the left of the bar.

If you specify direction as LEFT, the bar graph flows toward the left-hand edge of the screen. Any title or numeric value label for the bar appears to the right of the bar itself. The cursor position determines the lower left-hand corner of the bar.

**cells** - specifies the maximum number of whole character cells used in the bar graph. You might specify a small bar graph as having 3 or 4 cells. You might specify a large bar graph that nearly fills the screen as having 20 cells when direction is UP or DOWN, or 60 cells when direction is LEFT or RIGHT.

**min** - specifies the minimum value of item to output to the graph; for example, 1 gallon or 0 degrees.

**max** - specifies the maximum value of item to output to the graph; for example, 100 gallons or 2000 degrees.

**string** - specifies the title that optionally labels a bar. If you specify direction as UP, the title specified by string appears at the bottom of the bar and the bar appears as wide as the title. If you specify direction as DOWN, the title specified by string appears at the top of the bar and the bar appears as wide as the title. If you specify direction as RIGHT, the title specified by string appears at the left of the bar. If you specify direction as LEFT, the title specified by string appears at the right of the bar.

The title often identifies the graphed item or the units of measurement for the graphed item; for example, Temp, Gallons, or Furnace #1.

**format-string** - identifies the format string that controls the appearance of the graphed numeric value label for the bar. If you do not specify a format string with the USING clause, the system uses the format specified by the USE FORMAT command.

If you specify direction as UP, the numeric value appears at the bottom of the bar and the bar appears as wide as the format that you specify. If you specify direction as DOWN, the numeric value appears at the top of the bar and the bar appears as wide as the format that you specify. If you specify direction as RIGHT, the numeric value appears at the left of the bar. If you specify direction as LEFT, the numeric value appears at the right of the bar.

You can use the following symbols in the format string:

**digits 0 - 9** - specifies the total size of the numeric field, including negative sign and decimal point, if any. For example, "3" specifies a field as 1.2, 22, -23, or 300, and "5" specifies a field as 12.34, -4.6 or 12345.

**#** - specifies a decimal digit with all leading or trailing zeros appearing. For example, "#### " specifies a number as 9999, 0023, 0000, -088, or -355.

**I** - specifies a decimal digit, with all leading zeroes suppressed. For example "IIII" specifies a number as 9999, 23, 0, -88, or -355.

The period (.) specifies the position for the decimal point. For example, "##.## " specifies a number as 44.22 or 05.90.

A number before any of the above specifications indicates that the system repeats the specification that number of times. For example, 4I and IIII are equivalent; 6#.2# and #####.## are equivalent.

As noted above, the system draws all graphs from the lower left-hand corner of the screen.

Use the CLEAR SCREEN command to stop a GRAPH statement.

Example 1: Using graphs that extend toward the top of the screen, show a single temperature with four different formats. The first uses a simple bar graph only, the second uses a bar graph with the title Temp, the third labels the graphed value, and the last graph displays both the graphed value and the title Temp.

```
CLEAR SCREEN
DOUBLE WIDE
'
MOVE TO 20, 26
RED
GRAPH TEMP1 UP 10 SCALE 0 TO 100
'
MOVE TO 21, 30
YELLOW
GRAPH TEMP1 TITLE "Temp" UP 10 SCALE 0 TO 100
'
MOVE TO 21, 40
GREEN
GRAPH TEMP1 USING "####" UP 10 SCALE 0 TO 100
'
MOVE TO 22, 48
CYAN
GRAPH TEMP1 USING "IIII" TITLE "Temp" UP 10 SCALE 0 TO 100
```

Example 2: Using graphs that descend toward the bottom of the screen, show a single temperature with four different formats. The first uses a simple bar graph only, the second uses a bar graph with the title Temp, the third labels the graphed value, and the last graph displays both the graphed value and the title Temp.

```

CLEAR SCREEN
DOUBLE WIDE
,
MOVE TO 20, 26
MAGENTA
GRAPH TEMP1 DOWN 15 SCALE 0 TO 100
,
MOVE TO 20, 30
WHITE
GRAPH TEMP1 TITLE "Temp" DOWN 15 SCALE 0 TO 100
,
MOVE TO 20, 40
BLUE
GRAPH TEMP1 USING "III" DOWN 15 SCALE 0 TO 100
,
MOVE TO 20, 56
GREEN
GRAPH TEMP1 USING "###" TITLE "Temp" DOWN 15 SCALE 0 TO 100

```

Example 3: Using graphs that flow toward the right-hand edge of the screen, show a single temperature with four different formats. The first uses a simple bar graph only, the second uses a bar graph with the title Temp, the third labels the graphed value, and the last graph displays both the graphed value and the title Temp.

```

CLEAR SCREEN
DOUBLE WIDE
,
MOVE TO 5, 38
RED
GRAPH TEMP1 RIGHT 20 SCALE 0 TO 100
,
MOVE TO 10, 26
YELLOW
GRAPH TEMP1 TITLE "Temp" RIGHT 20 SCALE 0 TO 100
,
MOVE TO 15, 26
GREEN
GRAPH TEMP1 USING "III" RIGHT 20 SCALE 0 TO 100
,
MOVE TO 20, 10
WHITE
GRAPH TEMP1 USING "###" TITLE "Temp" RIGHT 20 SCALE 0 TO 100

```

Example 4: Using graphs that flow toward the left-hand edge of the screen, show a single temperature with four different formats. The first uses a simple bar graph only, the second uses a bar graph with the title Temp, the third labels the graphed value, and the last graph displays both the graphed value and the title Temp.

```
CLEAR SCREEN
DOUBLE WIDE
,
MOVE TO 10, 5
BLUE
GRAPH TEMP1 LEFT 12 SCALE 0 TO 100
,
MOVE TO 12, 5
GREEN
GRAPH TEMP1 TITLE "Temp" LEFT 12 SCALE 0 TO 100
,
MOVE TO 14, 5
WHITE
GRAPH TEMP1 USING "III" LEFT 12 SCALE 0 TO 100
,
MOVE TO 16, 5
YELLOW
GRAPH TEMP1 USING "###" TITLE "Temp" LEFT 12 SCALE 0 TO 100
```

**VIEW item {ESC}<A “name” AVIEW item USING “format” {ESC}<A “name”;** string{ETX} A

These commands display the value for an item that you specify.

**item** - specifies the name of the data element that you want to display. Item is often an element such as TEMP, GALLONS, LEVEL, or AMOUNT

**format-string** - identifies the format string that controls the appearance of the displayed value. If you do not specify a format string with the USING clause, the system uses the format specified by the USE FORMAT command.

You can use the following symbols in the format string:

**digits 0 - 9** - specifies the total size of the numeric field, including negative sign and decimal point, if any. For example, “3” specifies a field as 1.2, 22, -23, or 300, and “5” specifies a field as 12.34, -4.6 or 12345.

**#** - specifies a decimal digit with all leading or trailing zeros appearing. For example, “#### ” specifies a number as 9999, 0023, 0000, -088, or -355.

**I** - specifies a decimal digit, with all leading zeroes suppressed. For example “IIII” specifies a number as 9999, 23, 0, -88, or -355.

The period (.) specifies the position for the decimal point. For example, “###.## ” specifies a number as 344.22, 27.02, or 1.1.

A number before any of the above specifications indicates that the system repeats the specification that number of times. For example, 4I and IIII are equivalent; 6#.2# and #####.## are equivalent.

Use the CLEAR SCREEN command to stop a VIEW statement.

Example: Using the VIEW command, show a single temperature with three different formats. The first display uses the simplest default format, the second display uses the Temperature label and a format statement, and the last display uses quad-sized characters and a format statement.

```
' VIEWDEMO1 - OptiSCREEN file demonstrating VIEW
,
VIEW command.
'
CLEAR SCREEN
MOVE TO 6, 20
VIEW TEMP1
MOVE TO 8, 20
DISPLAY "Temperature: "
VIEW TEMP1 USING "####"
MOVE TO 14, 20
YELLOW
QUAD SIZE
VIEW TEMP1 USING "IIII"
EXIT QUAD
```

Example: Using the VIEW command, show a single temperature with three different formats. The first display uses the simplest default format, the second display uses the Temperature label and a format statement, and the last display uses quad-sized characters and a format statement.

```
VIEW item OFF: file ON: file{ESC}<B "name"; "file"; "file"
VIEW item OFF: "string" ON: "string" {ESC}<B "name"; string{ETX}; string{ETX}
VIEW item OFF: "string" ON: file {ESC}<B "name"; string{ETX}; "file"
VIEW item OFF: file ON: "string" {ESC}<B "name"; "file"; string{ETX}
```

These commands display the OFF or ON switch setting for an item.

**item** - specifies the name of the data element that you want to display. Item is often an element such TEMP, GALLONS LEVEL, or AMOUNT.

**file** - specifies the name or number of the OptiSCREEN file that holds the attributes and graphic output for the OFF or ON switch setting of item.

**string** - specifies the text string for display with the OFF or ON switch setting of item.

Use the CLEAR SCREEN command to stop a VIEW statement.

Example: Using the VIEW OFF/ON command, show the setting for a pump using the text OFF and ON. Below the textual display, create a graphic display that shows setting of the pump. Three separate OptiSCREEN files appear below: VIEWDEMO2, PUMPOFF, and PUMPON. The VIEWDEMO2 file calls PUMPOFF and PUMPON.

```
' VIEWDEMO2 - OptiSCREEN file demonstrating
'
'           VIEW OFF/ON command.
'
' ----- Display title -----
CLEAR SCREEN
WHITE
BLACK
MOVE TO 3, 14
DOUBLE WIDE
DISPLAY "VIEW item OFF/ON commands"
EXIT DOUBLE WIDE AND BLINK
'
' ----- Demonstrate VIEW item OFF: "string" ON: "string" -----
WHITE
MOVE TO 10, 28
DOUBLE SIZE
DISPLAY "Pump 1: "
VIEW OUTPUT OFF: "OFF" ON: "ON "
EXIT DOUBLE WIDE AND BLINK
'
' ----- Demonstrate VIEW item OFF: file ON: file -----
MOVE TO 18, 36
SAVE POSITION
BOX 2 x 6
UP 2
RIGHT
QUAD SIZE
DISPLAY "e"
EXIT QUAD
RESTORE POSITION
VIEW OUTPUT OFF: PUMPOFF ON: PUMPON
END

'----- PUMPOFF ----- OptiSCREEN file for VIEWDEMO2
'
'           Pump Off Setting
RED
/BLACK
BOX ATTRIBUTES 5 X 6
WHITE
END

'----- PUMPON ----- OptiSCREEN file for VIEWDEMO2
'
'           Pump On Setting
GREEN
/BLACK
BOX ATTRIBUTES 5 X 6
WHITE
END
```

## GROUP nn GRAPHS {ESC}<D nnn D GROUP nn GRAPHS, TITLE “string” {ESC}<D nnn; title{ETX} D

The GROUP command causes graphs and graphic output to appear in boxed clusters, or a “display template.”

**nn** - specifies the number of graphs grouped together inside a box.

**string** - specifies the title string that appears above the group of graphs and graphic output. If you do not specify a title, the graphs and output appear without a heading.

The system determines the size of the “display template” and the position of the graphs from the included graph statements and their parameters. Do not use any “positioning statements” between the GRAPH commands of a single GROUP.

Example: This example generates a single light blue bar graph, and then groups three multicolored graphs.

```
'Test: Group three graphs
MOVE TO 13, 0
CYAN
GRAPH SET_TEMP RIGHT 75 SCALE 0 TO 200
MOVE TO 20, 0
GROUP 3 GRAPHS
RED
GRAPH TEMP1 RIGHT 25 SCALE 0 TO 75
YELLOW
GRAPH TEMP1 RIGHT 25 SCALE 76 TO 125
WHITE
GRAPH TEMP1 RIGHT 25 SCALE 126 TO 200
END
```

## USE FORMAT “format-string” {ESC}[ nnn A

This command specifies the format for numbers displayed with the GRAPH and VIEW commands. If you specify a USING clause in the GRAPH or VIEW command, the system overwrites the setting specified with the USE FORMAT command.

**digits 0 - 9** - specifies the total size of the numeric field, including negative sign and decimal point, if any. For example, “3” specifies a field as 1.2, 22, -23, or 300, and “5” specifies a field as 12.34, -4.6 or 12345.

**#** - specifies a decimal digit with all leading or trailing zeros appearing. For example, “#### ” specifies a number as 9999, 0023, 0000, Ä088, or -355.

**I** - specifies an integer, with all leading zeroes suppressed. For example “IIII” specifies a number as 9999, 23, 0, -88, or -355.

The period (.) specifies the position for the decimal point. For example, “2.3” specifies a number as 23.124 or -3.1, and the format-string “###.## ” specifies a number as 344.22, 27.02, or 1.1.

A number before any of the above specifications indicates that the system repeats the specification that number of times. For example, 4I and IIII are equivalent; 6#.2# and #####.## are equivalent.

If leading digits or a negative sign do not fit into a format specified by a format string, the system fills the data display with asterisks (\*).

If trailing digits do not fit into a format specified by a format string, the system rounds the number to fit.

The following table gives examples of format-strings and resulting numeric and string values.

Format string	Examples of output				
IIII	1234	23	0	-893	-6
####	1234	0023	0000	-893	-006
4I	1234	23	0	-893	-6
IIII	234	23	0	-893	-6
####.##	1234.12	0023.30	0000.00	-893.03	-006.10

Example: Show the same data value four different ways.

```

CLEAR SCREEN
MOVE TO 2, 10
VIEW MYTEMP USING "####"
MOVE TO 4, 10
VIEW MYTEMP USING "####.###"
MOVE TO 6, 10
USE FORMAT "IIII"
VIEW MYTEMP
MOVE TO 8, 10
USE FORMAT "3.2"
VIEW MYTEMP
END

```

The system shows MYTEMP, when it has no value, with the following output:

```

0000
0000.000
0
0

```

The system shows MYTEMP, when it reaches a value of 130.99, with the following output:

```

0131
0130.990
131
130.99

```

## Data Fill Operations

In many situations, you will want to create a screen file that includes numerous blanks for the host to later fill in with data. In order to fill in these blanks, the host must perform some form of cursor positioning before sending the data for the blank field. To simplify the cursor positioning the Screen Display and Data Fill escape sequence (Esc [ > n f) has been developed.

To perform this operation you will normally create two screen files, using the OptiSCREEN Editor. Screen file 1 will contain the text portion of the screen only. Screen file 2 will contain special place holders in the form of [Ctrl]-E {ENQ} characters where data from the host is to be sent.

First, the host will display file 1, the text portion of the screen, using the Screen Display escape sequence (Esc [ > n w). Next, when the host is ready to send data, it will use the Screen Display and Data Fill escape sequence (Esc [ > n f) to display the screen file 2 containing the blank space place holders. Then the host sends the data. When the host is ready to send data again it uses the Screen Display and Data Fill escape sequence to display the blanks only before sending data.

When the Screen Display and Data Fill escape sequence is executed, the screen will be processed only up to the first [Ctrl]-E encountered. At this point, data received from the host in On-Line mode, or from the keyboard in Local mode, will be placed on the screen instead of spaces. As each additional character is received, it will be used to fill the blanks in the file where [Ctrl]-E was placed. As the screen file is being processed, when a character other than [Ctrl]-E is again encountered, normal file display will resume.

If a non-displayable character is received in the data to be filled in on the screen (e.g., a carriage return, line feed), spaces will automatically be put on the screen for each [Ctrl]-E in the same data field. A field is considered to end when a character other than [Ctrl]-E is found in the display file. In this manner a field of 6 [Ctrl]-Es for a particular data value may use fewer than 6 characters and be left justified in the blanks reserved for the data.

The host or application program can terminate a Data Fill sequence prior to sending all of the characters required to fill the fields on the screen by sending a [Ctrl]-C (End of Text). In this manner, only the highest priority fields on the screen can be updated if desired.

The format for the Display File and Data Fill escape sequence (normally sent from the host) is:

```
Esc [ > n f data data data ... data ETX
```

The file number is n; the ETX is optional and only required if fewer data characters are sent than the blank fields in the file. An example of this operation is shown below.

### Example Data Fill Operation

The display below is created using two separate screen files. Lower-case e's are used to show where the fill character ([Ctrl]-E) has been placed.

```
CURRENT SETPOINT:  eeeee
CURRENT HIGH ALARM: eeeee
CURRENT LOW ALARM:  eeeee

CURRENT TEMPERATURE: eeeee
HIGHEST TEMPERATURE THIS BATCH: eeeee
LOWEST TEMPERATURE THIS BATCH: eeeee
```

The text of the screen was created by the OptiSCREEN Editor as shown below:

```

CLEAR SCREEN
HOME
DISPLAY "CURRENT SET POINT:"
MOVE 1, 2
DISPLAY "CURRENT HIGH ALARM:"
MOVE 1, 3
.
.
.
END

```

A second file was then created to include the blank space place holders.

```

MOVE TO 1, 20
DISPLAY "{ENQ}{ENQ}{ENQ}{ENQ}{ENQ}"  The {ENQ} character is the
MOVE TO 2, 22                          blank space created by
DISPLAY "{ENQ}{ENQ}{ENQ}{ENQ}{ENQ}"  pressing Ctrl-E.
MOVE TO 3, 19
.
.
.
END

```

In the example above, the operations in the first file could have been included in the second file. But, using a separate file for the data fill operation allows the host to repeat displaying of data without redisplaying the text portion of the screen.

The following Series Five ASCII/BASIC program running in the host could be used to display the file and then fill in the blanks. Note that the syntax used in this example may vary depending upon the type of BASIC being used.

```

10 PRINT CHR(27), "[>1w" : REM print screen one
20 PRINT CHR(27), "[>2f" : REM print screen two fill command
30 . . .
40 . . .
50 PRINT A                : REM first data field
60 PRINT B                : REM second data field
.
.
.

```

In the above example, it was assumed that the variables A and B would be 5 characters or less. Each of the BASIC Print statements will send a Carriage Return and Line Feed after each variable. If a variable was less than 5 characters, then spaces would automatically be used to pad out the fields. Therefore, each field is automatically left-justified and trailing spaces are added as needed to erase old data that may have been in the field.

## Command Summary

The following command summary gives the format, a short description for each command, and the page number where the command is fully documented. In the following summary, brackets appear around optional arguments.

**'comment** (Comment) Specifies that the rest of the line is a comment.

**[Ctrl]-E {ENQ}** (Data Fill) Holds space on display for character sent from host.

**ALTERNATE** (Character attribute) Establishes the alternate character set as the current mode.

**ATTRIBUTES: [nn,] nn, nn** (Character attribute) Establishes two or more character attributes as the current mode.

**AUTO LINE FEED ON RETURN** (Configuration) Forces an automatic line feed to occur with a carriage return.

**AUTO RETURN ON LINE FEED** (Configuration) Forces an automatic carriage return to occur with a line feed.

**AUTO WRAP AT END OF LINE** (Configuration) Forces automatic line wrapping to occur at the end of a filled line.

**BAUD nnn** (Configuration) Sets the programmable communications baud rate.

**BLACK and /BLACK** (Character attribute) Sets the foreground and background colors to black.

**BLINK** (Character attribute) Establishes the blinking character attribute mode.

**BLINKING CURSOR (Cursor)** Makes the cursor blink on the screen.

**BLOCK CURSOR (Cursor)** Makes the cursor appear as a solid block.

**BLUE and /BLUE** (Character attribute) Sets the foreground and background colors to blue.

**BOX ATTRIBUTES rr X cc** (Graphics) Applies the currently defined character attributes to a boxed region *rr* rows tall and *cc* columns to the right.

**BOX rr X cc** (Graphics) Creates an outlined box *rr* rows tall and *cc* columns to the right.

**BRIGHT and /BRIGHT** (Character attribute) Sets the monochrome foreground and background intensity to higher than normal.

**BRIGHT UNDERLINE** (Character attribute) Sets the monochrome foreground intensity level to BRIGHT and underlines the text.

**CLEAR KEY TABLE** (Programmable Keyboard) Makes all programmable key values null.

**CLEAR LINE** (Erasing and editing) Clears the contents of the current line.

**CLEAR LINE FROM CURSOR** (Erasing and editing) Clears the contents of the current line from the cursor to the end of the line.

**CLEAR LINE TO CURSOR** (Erasing and editing) Clears the contents of the current line from the beginning of the line to the cursor.

**CLEAR SCREEN** (Erasing and editing) Moves the cursor to the home position, clears the screen, and resets all attributes to normal.

**CLEAR SCREEN FROM CURSOR** (Erasing and editing) Clears the screen from the cursor to the end of the screen.

**CLEAR SCREEN TO CURSOR** (Erasing and editing) Clears the screen from the home position to the cursor.

**CLEAR STATUS LINE** (Erasing and editing) Clears the status line or lines at the bottom of the screen.

**CURSOR** (Cursor) Makes the cursor visible.

**CYAN and /CYAN** (Character attribute) Sets the foreground and background colors to light blue.

**DARK and /DARK** (Character attribute) Sets the monochrome foreground and background intensity to dark.

**DEFAULT KEY TABLE** (Programmable keyboard) Sets the programmable keyboard to the default key table.

**DELETE [nn] CHARACTERS** (Erasing and editing) Erases one or nn characters to the right.

**DELETE [nn] LINES** (Erasing and editing) Deletes one or nn lines.

**DIM and /DIM** (Character attribute) Sets the monochrome foreground and background intensity to lower than normal.

**DIM UNDERLINE** (Character attribute) Sets the monochrome foreground intensity level to DIM and underlines the text.

**DISABLE DATE** (Clock and date) Disables the date at the bottom of the screen.

**DISABLE TIME** (Clock and date) Disables the time at the bottom of the screen.

**DISPLAY "text"** (Display) Displays the string text.

**DISPLAY DATE HERE** (Clock and date) Move the date display from the bottom of the screen.

**DISPLAY DIRECTORY** (File display) Displays the OptiSCREEN file names.

**DISPLAY FILE** (File display) Displays OptiSCREEN file nn.

**DISPLAY FILE MEMORY** (File display) Displays file memory.

**DISPLAY KEY TABLE** (Programmable keyboard) Displays the current key table.

**DISPLAY TIME HERE** (Clock and date) Move the time display from the bottom of the screen.

**DOUBLE SIZE ["text"]** (Line attribute) Establishes double size as the current line attribute mode or displays text double size.

**DOUBLE WIDE** (Character attribute) Establishes the double wide character set as the current mode.

**DOUBLE WIDE LINE** (Line attribute) Establishes double wide as the current line attribute mode.

**DOWN [nn]** (Cursor) Moves the cursor down one or nn rows.

**DRAW BAR direction [cc X] pp** (Graphics) Generates a bar graph that extends in the specified direction (UP, DOWN, LEFT, or RIGHT) for pp pixels and, if specified, cc columns to the right or above.

**EMPTY BOX rr X cc** (Graphics) Creates an empty box rr rows tall and cc columns to the right.

**ENABLE DATE** (Clock and date) Enables the date at the bottom of the screen.

**ENABLE TIME** (Clock and date) Enables the time at the bottom of the screen.

**END** (End of File) Indicates the end of the OptiSCREEN file.

**ERASE BAR direction [cc X] pp** (Erasing and editing) Erase a bar in the specified direction (UP, DOWN, LEFT, or RIGHT) for pp pixels and, if specified, cc columns above or to the right.

**EXIT ALTERNATE** (Character attribute) Exits the alternate character set.

**EXIT DOUBLE WIDE AND BLINK** (Character attribute) Resets the double wide and blinking character attributes to normal.

**EXIT QUAD** (Character attribute) Exits the quad character set.

**EXIT SUPPLEMENTAL** (Character attribute) Exits the supplemental character set.

**FILL BOX rr X cc WITH “a”** (Graphics) Creates a box rr rows tall and cc columns to the right filled with character a.

**FUNCTION KEY nn PERFORMS file** (Function key) Loads function key nn so that it executes OptiSCREEN file when pressed.

**GRAPH item [USING “format”] [TITLE “string”] direction cells SCALE min TO max** (VIEW command available with OptiBASIC) Dynamically generates a bar graph for the data element named item that extends in a specified direction (UP, DOWN, LEFT, or RIGHT) for a maximum number of cells. The scaling for the graph falls between min and max. If desired, indicate the graphed value to appear in a specific format. Specify a title for the graph as string.

**GREEN and /GREEN** (Character attribute) Sets the foreground and background colors to green.

**GROUP nn GRAPHS[, TITLE “string”]** (VIEW command available with OptiBASIC) Generates a display template for the next nn graphs. If desired, specify a title for the boxed cluster as string.

**HOME** (Cursor) Moves the cursor to row 1 and column 1.

**HORIZONTAL BAR GRAPH nn, ff, mm** (Graphics) Generates a horizontal bar graph nn whole cells to the right, ff (0 to 99) fractional cells to the right, and mm maximum cells to the right.

**INDEX** (Cursor) Moves the cursor down one row.

**INSERT [nn] LINES** (Erasing and editing) Inserts one or nn lines below the cursor.

**KEY mmm PERFORMS file** (Key) Loads decimal key value mmm so that it executes OptiSCREEN file when pressed.

**LEFT [nn]** (Cursor) Moves the cursor left one or nn columns.

**LINE rr** (Cursor) Moves the cursor to the beginning of line rr.

**LOAD FUNCTION KEY nn WITH “text”** (Function key) Loads function key nn with ASCII values text.

**LOAD KEY nn WITH vvv** (Programmable keyboard) Loads key nn with character vvv.

**LOAD KEY TABLE nn** (Programmable keyboard) Loads key table nn.

**MAGENTA and /MAGENTA** (Character attribute) Sets the foreground and background colors to purple.

**MOVE TO rr[, cc]** (Cursor) Moves the cursor to row rr and column cc.

**NEW LINE** (Cursor) Moves the cursor down to the beginning of the new line.

**NO AUTO LINE FEED** (Configuration) Disables the automatic line feed that occurs with a carriage return.

**NO AUTO RETURN** (Configuration) Disables the automatic carriage return that occurs with a line feed.

**NO AUTO WRAP** (Configuration) Disables the automatic line wrapping facility at the end of lines.

**NO CURSOR** (Cursor) Disables the cursor on the screen.

**NORMAL and /NORMAL** (Character attribute) Sets the monochrome foreground and background intensity to normal.

**PRINT SCREEN TO PORT n[, GRAPHIC TYPE g]** (Data transmission) Specifies port 1, 2, or 3 as the output location for a copy of the current screen.

**QUAD SIZE** (Character attribute) Establishes the quad character set as the current mode.

**RED and /RED** (Character attribute) Sets the foreground and background colors to red.

**RESET ATTRIBUTES** (Character attribute) Resets all character attributes to the default.

**RESET LINE ATTRIBUTES** (Line attribute) Resets all line attributes to the default operating mode.

**RESTORE POSITION** (Cursor) Returns the cursor to the location stored with SAVE POSITION.

**REVERSE INDEX** (Cursor) Moves the cursor up one row.

**REVERSED** (Character attribute) Establishes the reverse video character attribute mode.

**RIGHT [nn]** (Cursor) Moves the cursor right one or nn columns.

**SAVE POSITION** (Cursor) Stores the current location of the cursor for recall with RESTORE POSITION.

**SCROLL direction rr X cc** (Erasing and editing) Specifies the direction (UP, DOWN, LEFT, or RIGHT) for scrolling text and graphics rr rows and cc columns.

**SCROLL LINES nn TO pp** (Erasing and editing) Specifies the top line of the scrolling region as nn and the bottom line as pp.

**SET DEFAULT ATTRIBUTE** (Character attribute) Defines the currently set character attributes as the new default.

**SINGLE SIZE LINE** (Line attribute) Establishes single size as the current line attribute mode.

**START INSERT** (Erasing and editing) Begins the insertion mode to insert characters into text.

**STEADY CURSOR** (Cursor) Makes the cursor non-blinking on the screen.

**STOP INSERT** (Erasing and editing) Ends the insertion mode.

**SUPPLEMENTAL** (Character attribute) Establishes the supplemental character set as the current mode.

**TRANSMIT DIRECTORY VIA position PORT** (Data transmissions) Transmits a directory of the memory contents to the PRIMARY or SECONDARY port.

**TRANSMIT FILE fname VIA position PORT** (Data transmissions) Transmits the single file fname to the PRIMARY or SECONDARY port.

**UNDERLINE** (Character attribute) Sets the monochrome foreground intensity level to normal and underlines the text.

**UNDERLINE CURSOR** (Cursor) Makes the cursor appear as an underline character.

**UP [nn]** (Cursor) Moves the cursor up one or nn rows.

**USE FORMAT “format-string”** (VIEW command available with OptiBASIC) specifies the format for numbers displayed with the VIEW commands where format-string uses the digits 0 to 9 to represent the total size of the numeric field, # for decimal digits with leading or trailing zeroes, and I for integers without zeroes.

**VERTICAL BAR GRAPH nn, ff, mm** (Graphics) Generates a vertical bar graph nn whole cells up, ff (0 to 99) fractional cells up, and mm maximum cells up.

**VIEW item OFF: par1 ON: par2** (VIEW command available with OptiBASIC) Dynamically generates a Boolean display for the data element named item. Parameters par1 and par2 can be specified as either file or “string” for the display.

**VIEW item [USING “format”]** (VIEW command available with OptiBASIC) Dynamically generates a numeric display for the data element named item. If desired, indicate the value to appear in a specific format.

**WHITE and /WHITE** (Character attribute) Sets the foreground and background colors to white.

**YELLOW and /YELLOW** (Character attribute) Sets the foreground and background colors to yellow.

# Chapter 6

## *Utility Programs for the IBM PC*

---

---

### Introduction

With only a keyboard and the Operator Interface Terminal, the user can create, append, and delete screen files as well as program the function keys.

Included with each Operator Interface Terminal is a set of utility programs intended to enhance screen editing operations with the OIT. (These utility programs are provided on a floppy diskette under the manufacturer's logo.) These programs, as well as the following material describing their application, are provided through GE Fanuc Automation by the manufacturer of the OIT to aid in the development of application programs and screens.

#### Note

With respect to these utility programs, GE Fanuc Automation North America Inc. makes no warranty or representation whatsoever and the entire risk, of whatever kind, arising out of the use of such programs is assumed by the user.

### Installation

The programs contained on the utility program disk have been written for use on an IBM XT using BASICA. Due to differences in hardware or operating systems, users with other personal computers may find it necessary to modify the program.

The utility programs should be backed up on a second disk. No drive or directory references are included in the programs; they should run from any drive and any directory. For our own use, we have put DOS and BASICA on our disk along with an AUTOEXEC.BAT file so that the disk is bootable and will automatically execute the main utility program on powerup. You may elect to do the same by copying these programs onto a disk that has DOS and BASICA already.

The following steps can be used to combine the utility programs, DOS, and BASICA on the same disk.

1. With DOS resident on your default drive, enter at the DOS prompt (e.g. A>), "FORMAT Drive:/S" where drive is the destination drive containing a blank diskette. This command formats the blank disk and loads DOS onto the destination drive.

2. With BASICA resident on your default drive, enter at the DOS prompt, "COPY BASICA.COM Drive:" where drive again is your destination drive now containing your formatted disk with DOS. This will load BASICA onto that disk.
3. With the OIT utility disk installed on your default drive, now enter at the DOS prompt "COPY \*.\* Drive:" where drive is the destination drive now containing both DOS and BASICA.
4. At this time, the procedure is complete and installation of the newly created disk into the power-up default drive (generally drive A), followed by a system reset (by powering the PC down and back up, or by entering Control-Alternate-Delete), will cause the OIT utility programs to be automatically loaded and executed using the menu commands provided.

## Loading Utility Programs Without Resident DOS and BASICA

To use the utility programs when DOS and BASICA are not resident on the utility disk, follow this procedure:

1. Place a DOS diskette with BASICA resident into the PC's default drive. The PC will display a DOS prompt:

```
(Drive)>
```

2. Load BASICA into the PC by typing (exactly as shown):

```
BASICA /C:20000
```

The BASICA /C:20000 causes the PC to allocate 20,000 bytes of memory for the BASICA program in the communication buffer.

3. The PC will display the message:

```
OK
```

4. Now place the program utility diskette in the default drive, and type (exactly as shown):

```
RUN "IWS"
```

followed by a Carriage Return.

5. The screen will now display the Main Utility Program menu.

### Note

Loading the OIT program utility diskette in the above manner allocates the additional memory necessary for a larger communication buffer, as called for in the IWS.BAT file. This helps to prevent overflowing the buffer when a large file is uploaded from the OIT terminal to a PC using the IWS.BAS UTILITY PROGRAM.

## IWS.BAT - Start-Up Program

This program, which can be executed by typing OIT as the DOS prompt, will automatically load BASICA with the expanded communication buffer and start executing IWS.BAS.

## OIT - Main Utility Menu

The main utility program IWS.BAS is designed to be the program first executed under BASICA. This program provides a menu for each of the individual utility programs, and provides a common entry and exit point for the various programs.

Additional reserved entries have been made in the main menu for future utility programs or for custom user programs.

## IWSEDIT - Screen Editor

IWSEDIT.BAS, which may be invoked from the Main Utility menu, provides the means to create, append, and edit screen files. Any portion of existing files, as well as newly created files, can be changed using the menu driven commands provided in this program.

This program provides the ability to select screen attributes, character sets, graphic commands, and cursor positioning commands from a menu rather than having to memorize the corresponding escape sequences. In addition, screens can be stored individually on disk for later retrieval, and may be uploaded and downloaded into an OIT.

All information entered into a screen is automatically displayed on the OIT while it is also shown on the IBM display.

This program relies upon a link between the OIT primary port and the IBM COM1 port. It creates and acts upon screens having a .SCR extension.

For the program to work in the directory that IWSEDIT.BAS shares, at least one file must exist with the .SCR extension. (A file BLANK.SCR has been included on the disk for this purpose.)

Due to the nature of the way Microsoft BASICA handles string data, from time to time the program may appear to have stopped or locked up. This is usually due to Microsoft's process of collecting gaps in string memory when memory would otherwise be full. Allow your PC plenty of time to complete this process before giving up and starting over.

## IWSDOC - Documentation Program

IWSDOC.BAS is a second utility program that can be called from the Main Utility menu. Its function is to convert all characters in a screen file into displayable ASCII characters so that a hardcopy listing of a file's contents can be printed.

Under menu control, a screen file (having .SCR extension) is converted to a document file (having .DOC extension). The resulting file can be printed or output using standard DOS commands.

As before, at least one file must exist with the .DOC extension in order for the program to work, and a BLANK.DOC file has been included for this purpose.

Files created with this program are only intended to provide documentation or aid in editing screens using IWSEDIT. These files are not designed to be edited themselves.

---

## IWSLINK - STRLINK III Emulation

The STRLINK III is a digital cassette recorder used by many programmable controller manufacturers for tape program back-up. The OIT includes standard commands for this function.

For those users not having access to a STRLINK III, the IWSLINK utility program allows an IBM compatible computer to emulate a STRLINK III. This program provides a one-step complete back-up of all of user memory. This back-up image can later be reloaded into one or more Operator Interface Terminals.

The file created with this program has the extension .IWS. Except for very experienced programmers, these files would not be used for any other purposes.

This program uses the OIT secondary port; the others use the primary port.

# Appendix

# A

## Outline and Mounting Drawings

The following drawings and dimensions are subject to change without notice. Please confirm all dimensions with the actual product or the factory prior to fabrication of mounting equipment.

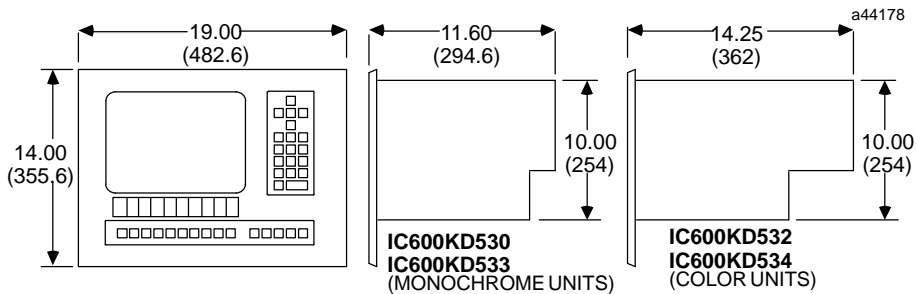

Figure A-1. Outline Drawing for OIT Models IC600KD530, 532, 533, and 534

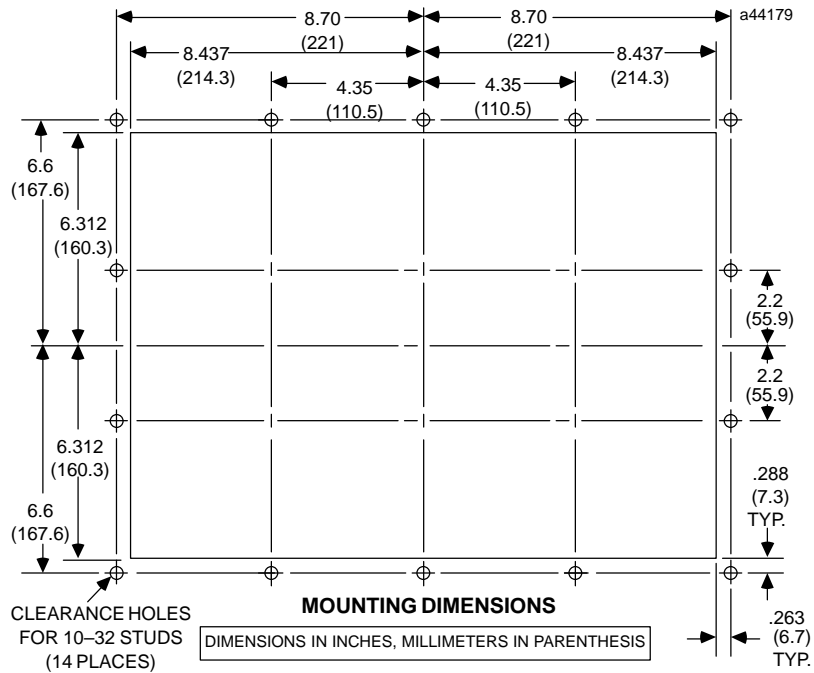

Figure A-2. Cutout Drawing for OIT Models IC600KD510, 512, 513, and 514

# Appendix B

## ASCII Codes and Special Character Sets

The OIT uses standard ASCII codes for display and communication. Additionally, the OIT offers special Supplemental Standard, Alternate, Supplemental Alternate, and Quad Size character and graphics sets.

### ASCII Codes and Characters

The decimal values, hexadecimal values, characters, and descriptions for the standard ASCII characters appear below. Characters marked with an asterisk (\*) are not processed.

Decimal	Hex	Character	Description
0	00	[Ctrl]-@	NUL, null or tape feed*
1	01	[Ctrl]-A	SOH, start of header
2	02	[Ctrl]-B	STX, start of text
3	03	[Ctrl]-C	ETX, end of text
4	04	[Ctrl]-D	EOT, end of transmission
5	05	[Ctrl]-E	ENQ, enquiry
6	06	[Ctrl]-F	ACK, acknowledge*
7	07	[Ctrl]-G	BEL, external bell output
8	08	[Ctrl]-H	BS, backspace
9	09	[Ctrl]-I	HT, horizontal tab
10	0A	[Ctrl]-J	LF, line feed
11	0B	[Ctrl]-K	VT, vertical tab*
12	0C	[Ctrl]-L	FF, form feed
13	0D	[Ctrl]-M	CR, carriage return
14	0E	[Ctrl]-N	SO, shift out
15	0F	[Ctrl]-O	SI, shift in
16	10	[Ctrl]-P	DLE, data link escape
17	11	[Ctrl]-Q	DC1, device control 1, XON
18	12	[Ctrl]-R	DC2, device control 2*
19	13	[Ctrl]-S	DC3, device control 3, XOFF
20	14	[Ctrl]-T	DC4, device control 4*
21	15	[Ctrl]-U	NAK, negative acknowledge*
22	16	[Ctrl]-V	SYN, synchronous idle*
23	17	[Ctrl]-W	ETB, end of transmission block
24	18	[Ctrl]-X	CAN, cancel escape sequence
25	19	[Ctrl]-Y	EM, end of medium*

Decimal	Hex	Character	Description
26	1A	[Ctrl]-Z	SUB, substitute*
27	1B	[Ctrl]-[	(leftsquare bracket) ESC, esc
28	1C	[Ctrl]-\	(backslash) FS, file separator*
29	1D	[Ctrl]-]	(rightsquare bracket) GS, group separator
30	1E	[Ctrl]-^	(caret) RS, record separator
31	1F	[Ctrl]-_	(underscore) US, unit separator*
32	20	[Space]	
33	21	!	(exclamationpoint)
34	22	“	(doublequotationmark)
35	23	#	(hatch, number sign, or pound)
36	24	\$	(dollarsign)
37	25	%	(percentsign)
38	26	&	(ampersand)
39	27	'	(apostrophe or single right quote)
40	28	(	(left or open parenthesis)
41	29	)	(right or close parenthesis)
42	2A	*	(asterisk or star)
43	2B	+	(plussign)
44	2C	,	(comma)
45	2D	-	(minus sign, hyphen, or dash)
46	2E	.	(period or dot)
47	2F	/	(slash or forwardslash)
48	30	0	(zero)
49	31	1	
50	32	2	
51	33	3	
52	34	4	
53	35	5	
54	36	6	
55	37	7	
56	38	8	
57	39	9	
58	3A	:	(colon)
59	3B	;	(semicolon)
60	3C	<	(less than)
61	3D	=	(equals)
62	3E	>	(greater than)
63	3F	?	(questionmark)
64	40	@	(at sign)
65	41	A	(begin uppercase letters)
66	42	B	
67	43	C	
68	44	D	
69	45	E	

Decimal	Hex	Character	Description
70	46	F	
71	47	G	
72	48	H	
73	49	I	
74	4A	J	
75	4B	K	
76	4C	L	
77	4D	M	
78	4E	N	
79	4F	O	
80	50	P	
81	51	Q	
82	52	R	
83	53	S	
84	54	T	
85	55	U	
86	56	V	
87	57	W	
88	58	X	
89	59	Y	
90	5A	Z	(end uppercase letters)
91	5B	[	(left or open bracket
92	5C	\	(backslash or reverse slash)
93	5D	]	(right or close square bracket)
94	5E	^	(up arrow sign or caret)
95	5F	_	(underscore)
96	60	'	(grave accent or single left quote)
97	61	a	(begin lowercase letters)
98	62	b	
99	63	c	
100	64	d	
101	65	e	
102	66	f	
103	67	g	
104	68	h	
105	69	i	
106	6A	j	
107	6B	k	
108	6C	l	
109	6D	m	
110	6E	n	
111	6F	o	
112	70	p	

Decimal	Hex	Character	Description
113	71	q	
114	72	r	
115	73	s	
116	74	t	
117	75	u	
118	76	v	
119	77	w	
120	78	x	
121	79	y	
122	7A	z	(end lowercase letters)
123	7B	{	(left or open squiggly brace)
124	7C		(vertical line)
125	7D	}	(right or open squiggly brace)
126	7E	~	(tilde)
127	7F	DEL	(delete or rubout)
128	80	[F1]	(begin function keys)
129	81	[F2]	
130	82	[F3]	
131	83	[F4]	
132	84	[F5]	
133	85	[F6]	
134	86	[F7]	
135	87	[F8]	
136	88	[F9]	
137	89	[F10]	
138	8A	[F11]	
139	8B	[F12]	
140	8C	[F13]	
141	8D	[F14]	
142	8E	[F15]	
143	8F	[F16]	(end function keys)
144	90	[Ctrl]-0	(begin control keys)
145	91	[Ctrl]-1	
146	92	[Ctrl]-2	
147	93	[Ctrl]-3	
148	94	[Ctrl]-4	
149	95	[Ctrl]-5	
150	96	[Ctrl]-6	
151	97	[Ctrl]-7	
152	98	[Ctrl]-8	
153	99	[Ctrl]-9	(end control keys)
154-	9A-		not used
169	A9		

<b>Decimal</b>	<b>Hex</b>	<b>Character</b>	<b>Description</b>
170–	AA–		IBM special key codes
171	AB		
172–	AC–		not used
175	AF		
176–	B0–		IBM special key codes
177	B1		
178	B2		Cursor down
179	B3		IBM special key code (page down)
180	B4		Cursor left
181	B5		not used
182	B6		Cursor right
183	B7		Home
184	B8		Up
185	B9		IBM special key code (page up)
186–	BA–		not used
191	BF		
192–	C0–		IBM special key codes
204	CC		
205–	CD–		not used
254	FE		
255	FF		no keystroke

## Supplemental Standard Graphics Set

From the Standard Character Set, you can enter the Supplemental Standard Graphics Set with the OptiSCREEN SUPPLEMENTAL command. Return to the Standard Character Set with the EXIT SUPPLEMENTAL command.

The Supplemental Standard Set includes the following:

numbers 0 to 9	(	:
uppercase A to Z	)	;
space	*	<
!	+	=
"	,	>
#	-	?
\$	.	@
%	/	[
&	]	\
'		

The Supplemental Standard Graphics Set appears below.

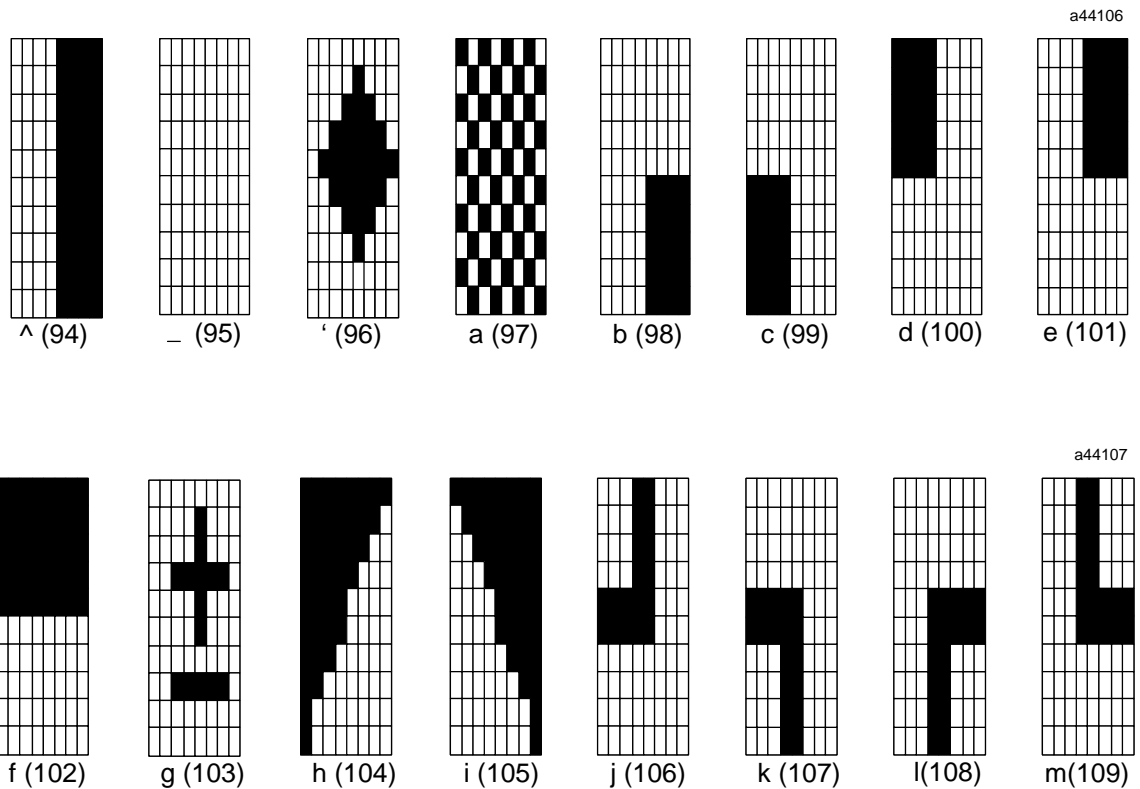

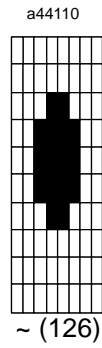
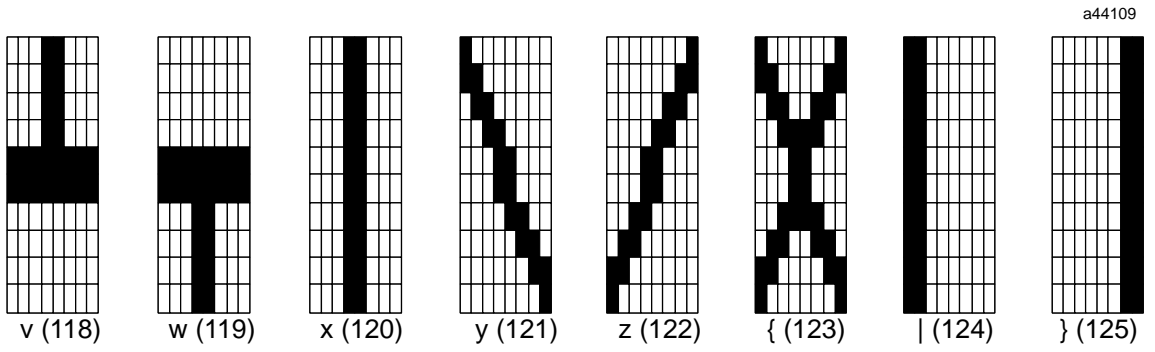
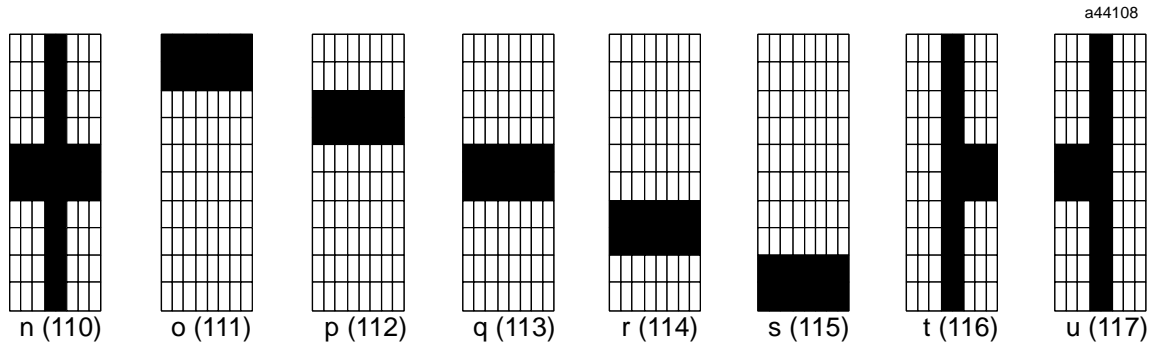

## Alternate Graphics Set

From the Standard Character Set, you can enter the Alternate Graphics Set with the OptiSCREEN ALTERNATE command. Return to the Alternate Graphics Set with the EXIT ALTERNATE command.

The Alternate Graphics Set appears below.

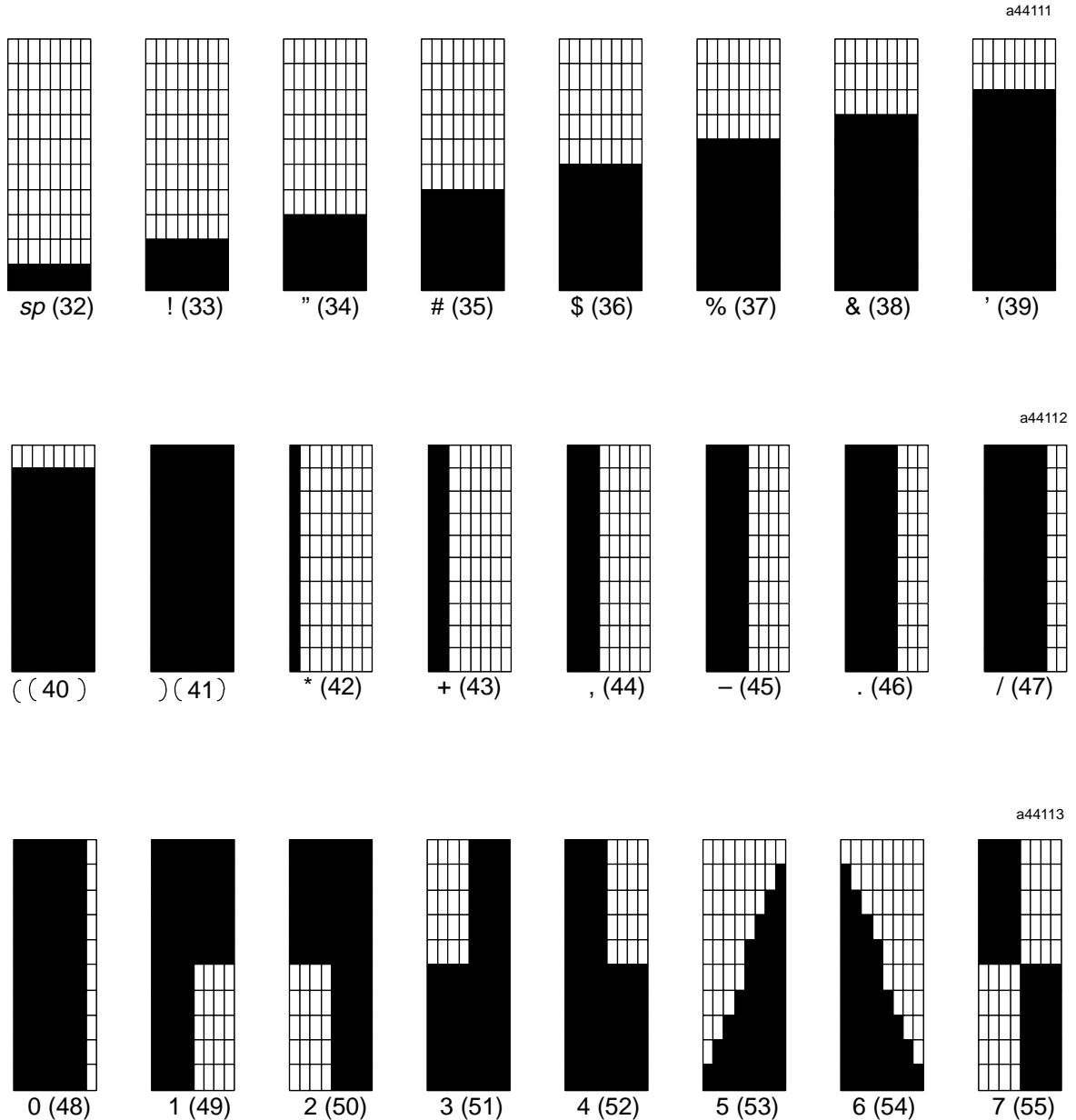

a44114

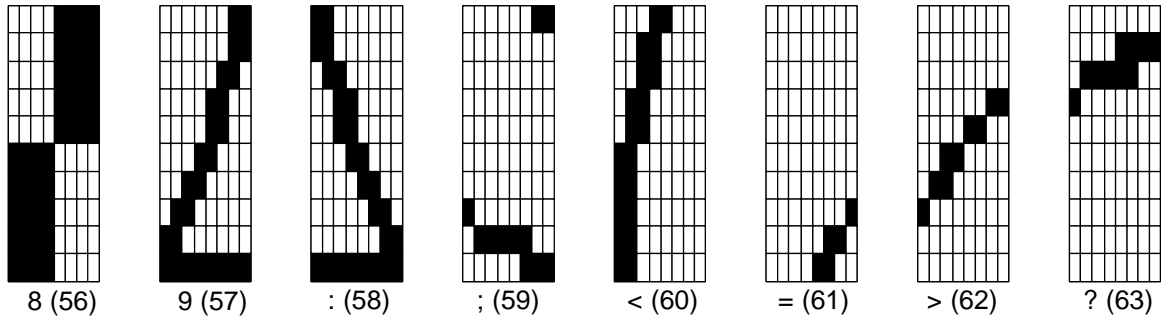

a44115

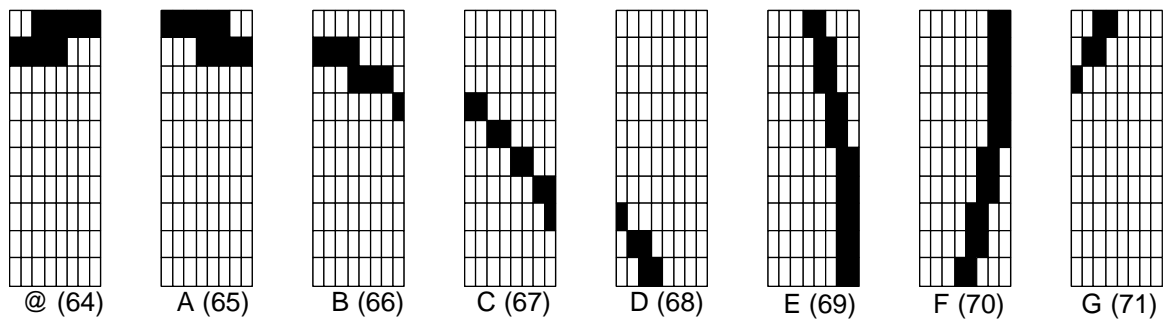

a44116

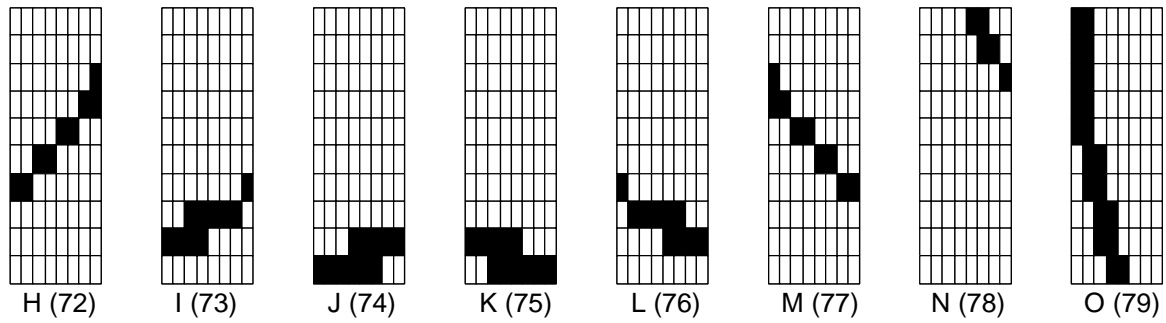

a44117

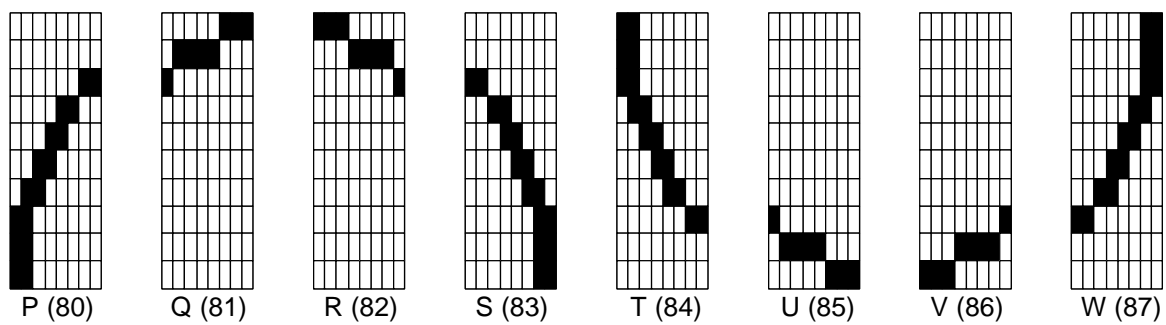

a44118

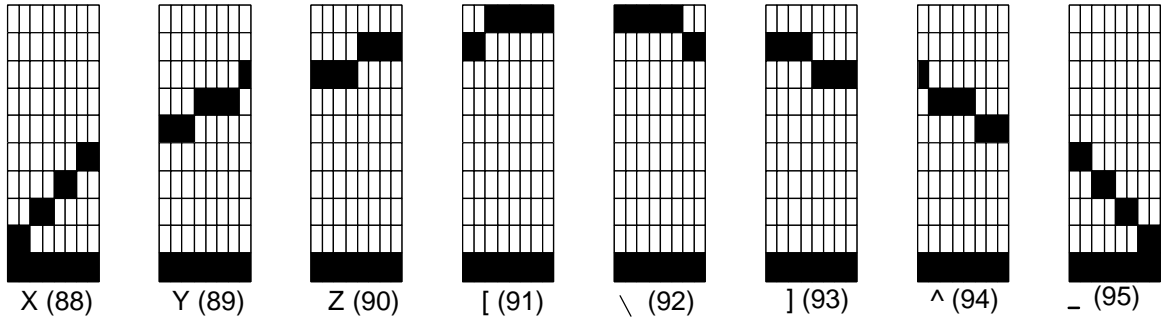

a44119

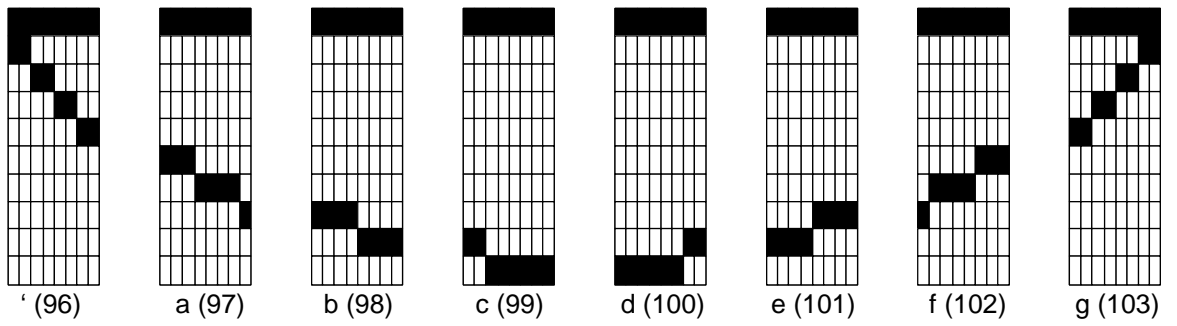

a44120

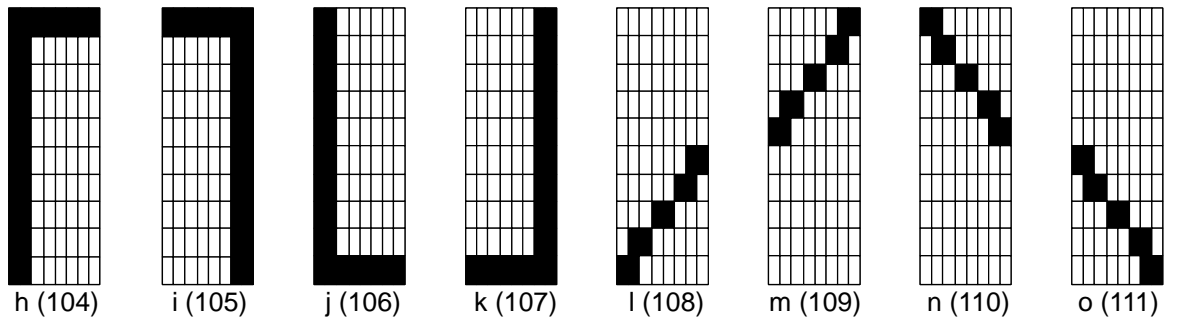

a44121

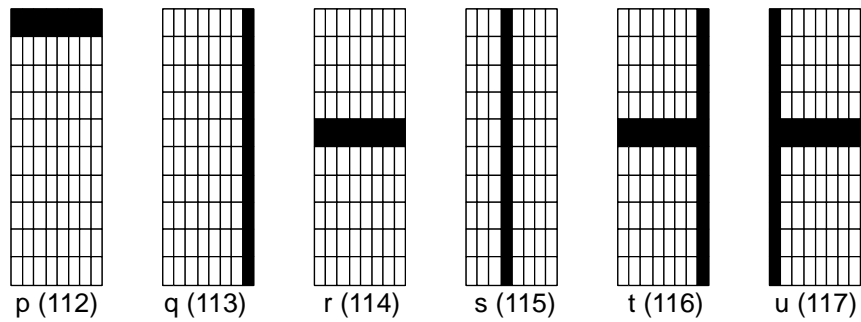

## Supplemental Alternate Graphics Set

From the Alternate Graphics Set (described above), you can enter the Supplemental Alternate Graphics Set with the OptiSCREEN SUPPLEMENTAL command. Return to the Alternate Graphics Set with the EXIT SUPPLEMENTAL command.

The Standard Supplemental Graphics Set appears below.

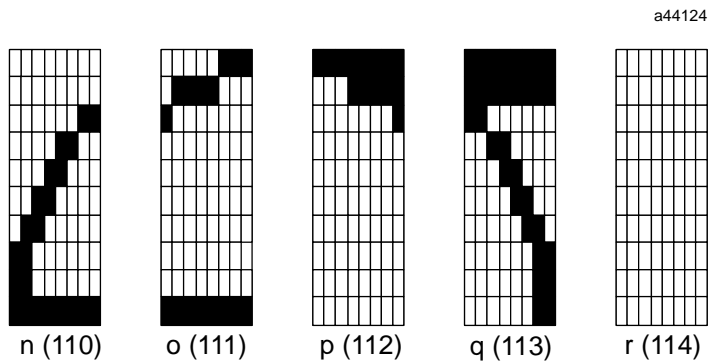
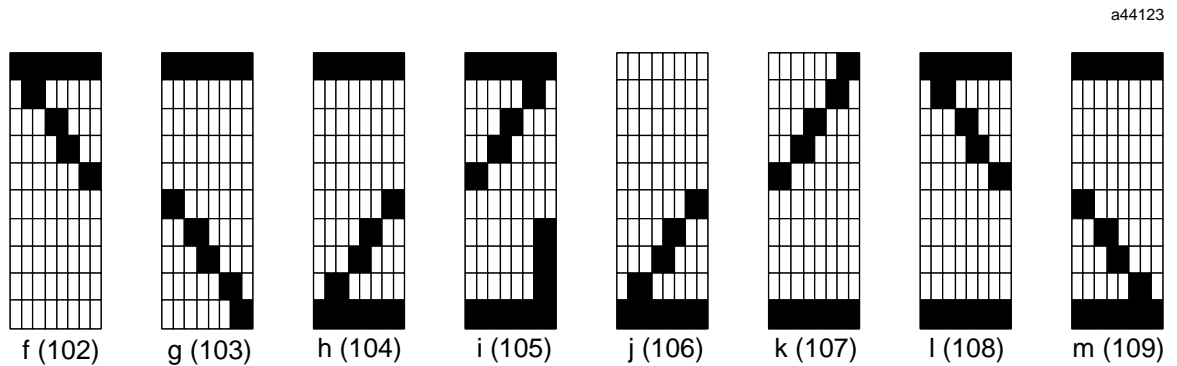
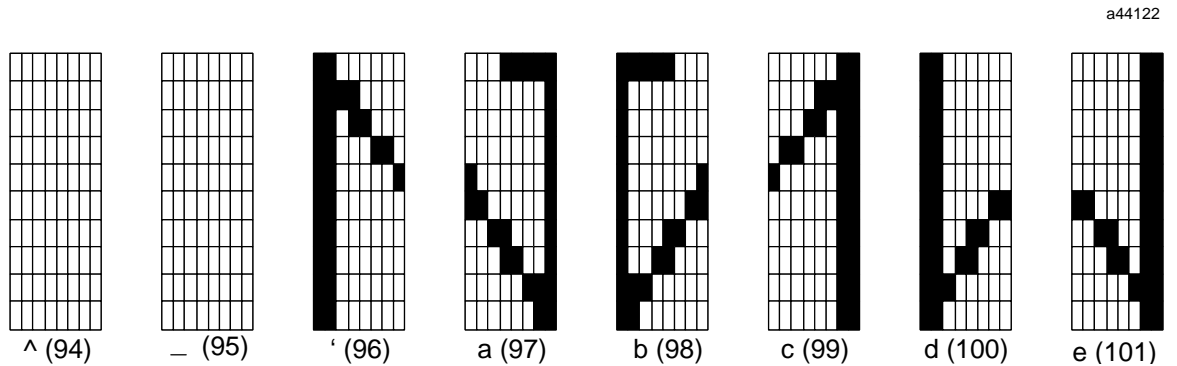

## Quad Size Character Set

From the Standard Character Set, you can enter the Quad Size Character Set with the OptiSCREEN QUAD command. Return to the Standard Character Set with the EXIT QUAD command.

The Quad Size Character Set includes the following:

numbers 0 to 9	,
uppercase A to Z	-
space	.
!	=
*	?
+	

The Quad Size Graphics Set appears below.

a44182

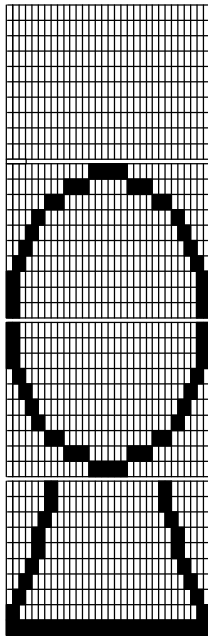

Motor  
" (34)

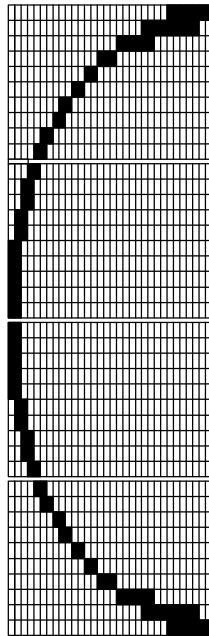

4 x 8 Circle  
Left  
# (35)

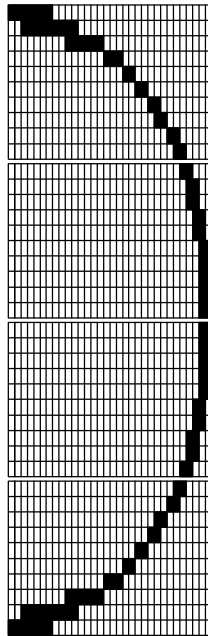

4 x 8 circle  
Right  
\$ (36)

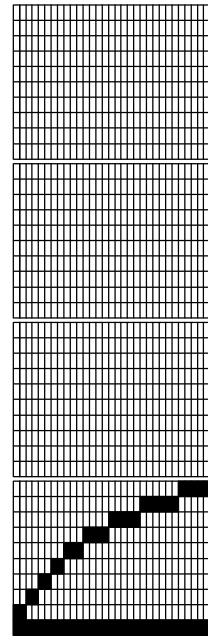

Tank Top  
Left  
% (37)

a44183

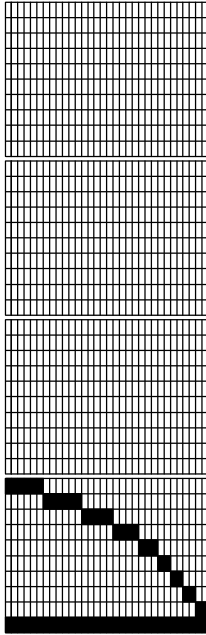

Tank Top  
Right  
& (38)

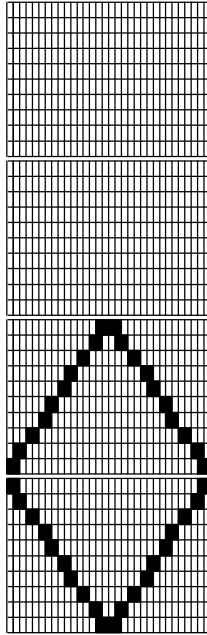

2 x 4 Diamond  
' (39)

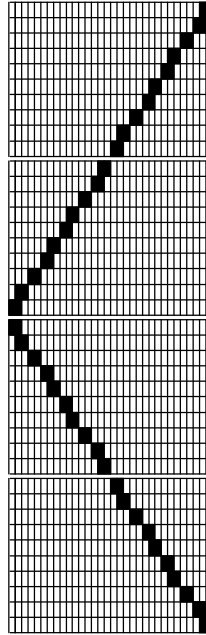

4 x 8 Diamond  
Left  
(( )

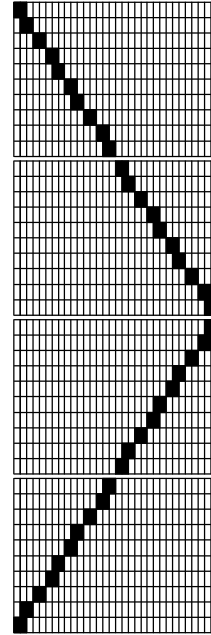

4 x 8 Diamond  
Right  
) ( )

a44184

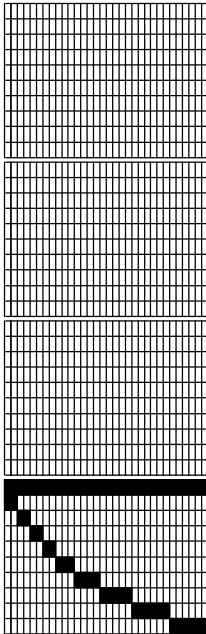

Tank Bottom  
Left  
: (58)

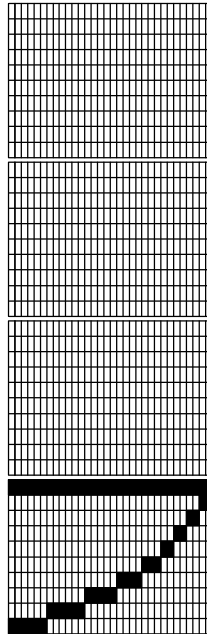

Tank Bottom  
Right  
; (59)

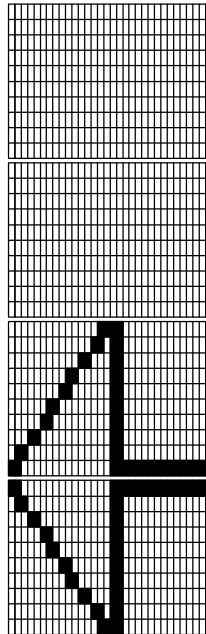

Left Arrow  
< (60)

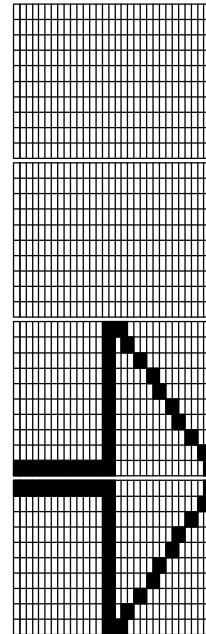

Right Arrow  
> (62)

a44185

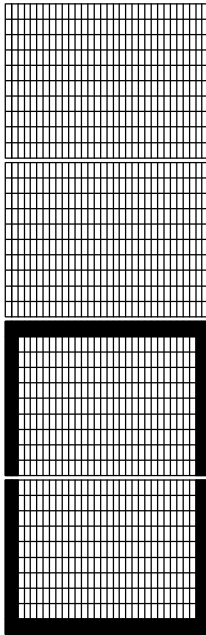

2 x 4 Box  
@ (64)

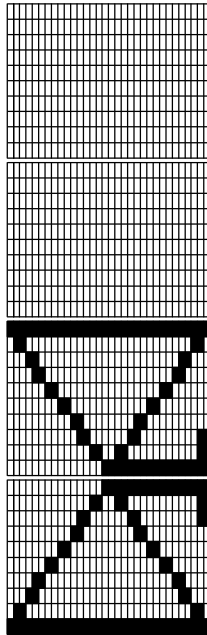

Valve Right  
[ (91)

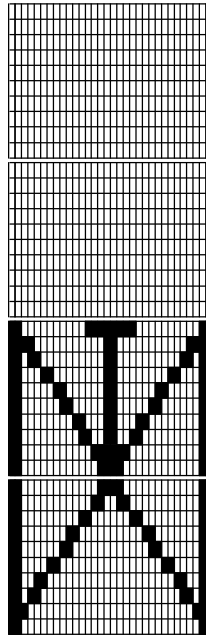

Valve Up  
\ (92)

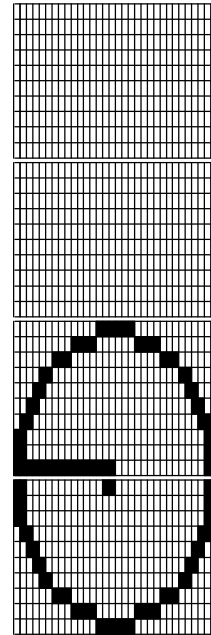

Pump/  
Compressor  
] (93)

a44186

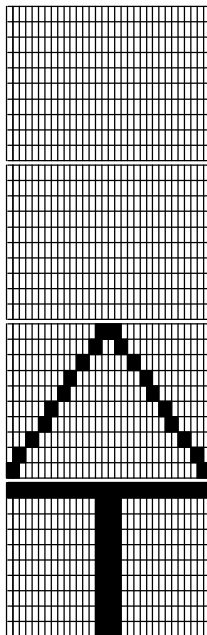

Up Arrow  
^ (94)

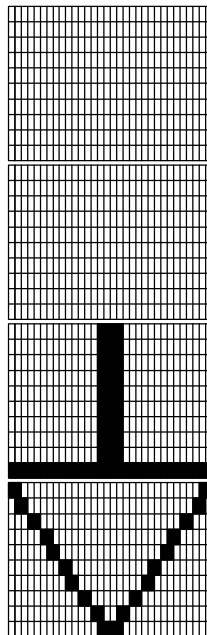

Down Arrow  
\_ (95)

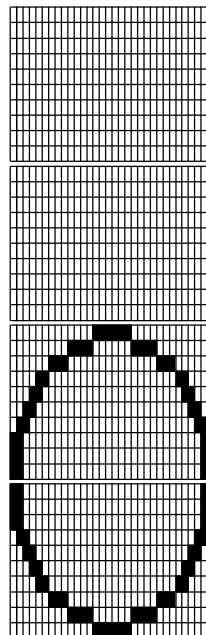

2 x 4 Circle  
' (96)

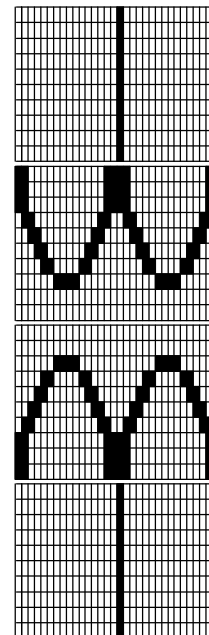

Transformer  
a (97)

a44187

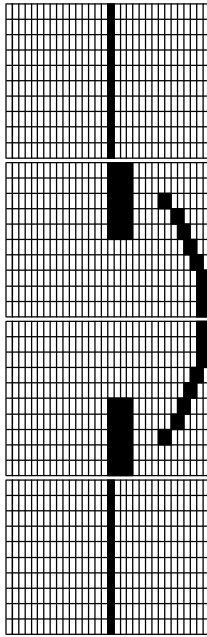

Circuit Breaker  
b (98)

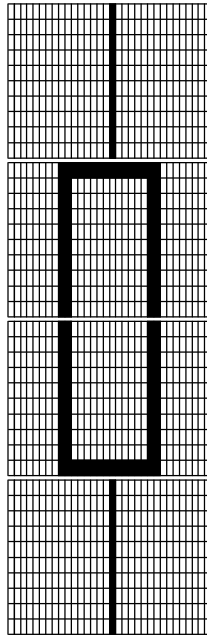

Fuse  
c (99)

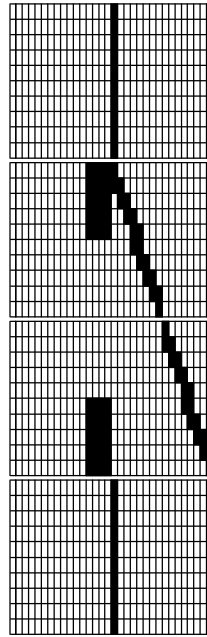

Disconnect  
d (100)

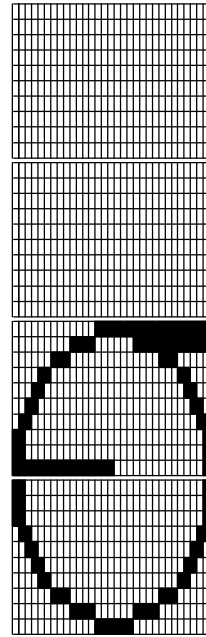

Pump/Blower  
e (101)

a44188

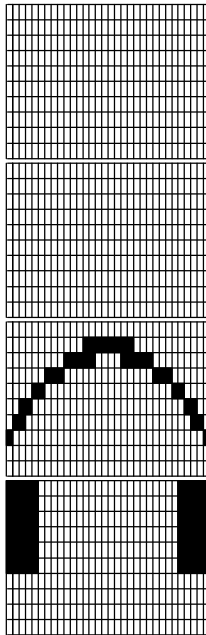

Circuit Breaker  
f (102)

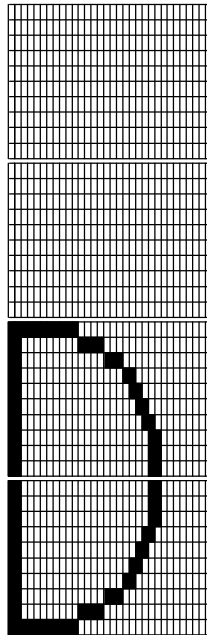

Turbine  
g (103)

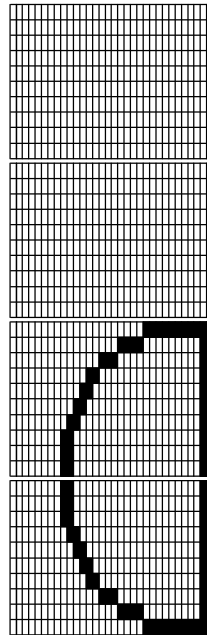

Turbine  
h (104)

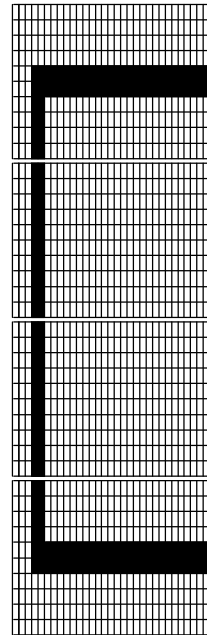

4 x 8 Box  
Left  
i (105)

a44189

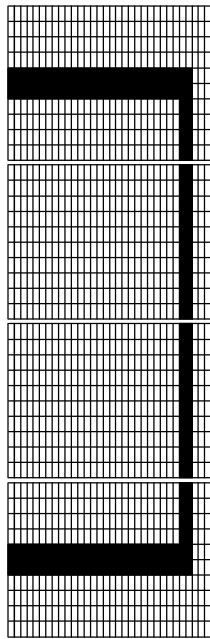

4 x 8 Box  
Right  
j (106)

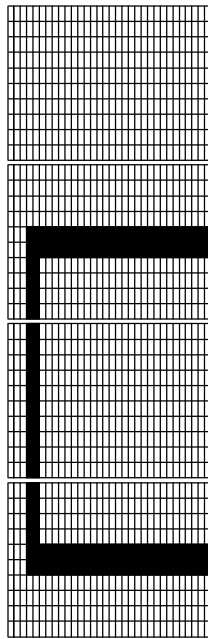

3 x 8 Box  
Left  
k (107)

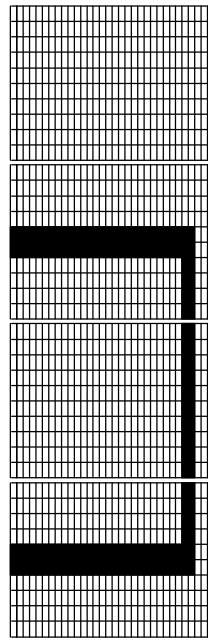

3 x 8 Box  
Right  
l (108)



# Appendix D

## *ANSI Escape Sequences for PLCs*

---

---

You may create an OptiSCREEN file with numerous blanks left for the host to fill with data. The file creation and appending procedures allow you to create the screen file using the [Ctrl]-E (ENQ, enquiry) control character for the locations on the screen where the system displays data. When you develop a screen, enter a [Ctrl]-E for each character to be filled. A blank space appears on the screen which will be filled with data.

When you use the standard screen display escape sequence ({ESC} [>nnnw where nnn specifies the screen), the system continues to place a space wherever you entered a [Ctrl]-E.

However, when you use the data file escape sequence ({ESC} [>nnnf where nnn specifies the screen), the system only processes up to the first [Ctrl]-E you entered. At this point, data received from the host in Online mode, from the keyboard in Local mode, or from an OptiBASIC PRINT statement in BASIC mode, is placed on the screen instead of spaces.

As the system receives each additional character, it uses the character to fill the blanks in the file where you placed a [Ctrl]-E. As the screen file is being processed, when a character other than a [Ctrl]-E is encountered, normal file display resumes until the next [Ctrl]-E is encountered.

In the event that a non-displayable character (such as a line feed) is received in the data to be filled on the screen, the system automatically places a space on the screen for all the [Ctrl]-E characters in the same data field. A field is considered to end when a character other than a [Ctrl]-E is found in the display file. In this manner, a field of six [Ctrl]-E characters for a particular data value may use fewer than six characters and be left justified in the blanks reserved for the data.

The host or application program can terminate a data fill sequence prior to sending all of the characters required to fill the fields on the screen by sending a [Ctrl]-C (ETX, end of text) control character. In this manner, only the highest priority fields on the screen can be updated.

The format for the data fill escape sequence appears below:

{ESC} [>nnnf data1, data2, ..., datan {ETX}

The file number is nnn. The {ETX} character is optional only required if fewer data characters are sent than the blank fields in the file.

A complete list of escape codes for use with PLCs appears below. The first column contains the escape sequences. The second column contains the OptiSCREEN command descriptions. Refer to Chapter 5 for detailed descriptions of the OptiSCREEN commands.

**Table D-1. Escape Sequence OptiSCREEN Command**

{SOH}{STX}	'
{SOH}remark{STX}	'remark
{ESC}12m	ALTERNATE
{ESC}nnnm	ATTRIBUTE: nnn
{ESC}nnn;nnnm	ATTRIBUTES: nnn, nnn
{ESC}nnn;nnn;nnnm	ATTRIBUTES: nnn, nnn, nnn
{ESC}>8h	AUTO LINE FEED ON RETURN
{ESC}9h	AUTO RETURN ON LINE FEED
{ESC}?7h	AUTO WRAP AT END OF LINE
{ESC}nnnW	BAUD nnn
{ESC}30m	BLACK
{ESC}40m	/BLACK
{ESC}5m	BLINK
{ESC}>11l	BLINKINGCURSOR
{ESC}>4h	BLOCK CURSOR
{ESC}34m	BLUE
{ESC}44m	/BLUE
{ESC}=lll;ccca	BOX ATTRIBUTES lll X ccc
{ESC}=lll;cccd	BOX lll X ccc
{ESC}33m	BRIGHT
{ESC}43m	/BRIGHT
{ESC}37m	BRIGHTUNDERLINE
{ESC}>98r	CLEARKEY TABLE
{ESC}2K	CLEARLINE
{ESC}0K	CLEARLINEFROM CURSOR
{ESC}1K	CLEARLINE TO CURSOR
{ESC}2J	CLEARSCREEN
{ESC}0J	CLEARSCREENFROM CURSOR
{ESC}1J	CLEARSCREEN TO CURSOR
{ESC}3J	CLEARSTATUS LINES
{ESC}cccF	COLUMN ccc
{ESC}>5l	CURSOR
{ESC}36m	CYAN
{ESC}46m	/CYAN
{ESC}30m	DARK
{ESC}40m	/DARK
{ESC}>99r	DEFAULT KEY TABLE
{ESC}P	DELETECHARACTER
{ESC}nnnP	DELETE nnn CHARACTERS
{ESC}M	DELETELINE
{ESC}nnnM	DELETE nnn LINES
{ESC}31m	DIM
{ESC}41m	/DIM
{ESC}35m	DIMUNDERLINE
{ESC}>5h	DISABLECURSOR
{ESC}?14l	DISABLEDATE
{ESC}?15l	DISABLETIME
{ESC}literal	DISPLAY "literal"
{ESC}j	DISPLAY DATEHERE
{ESC}>dw	DISPLAY DIRECTORY
{ESC}{> "fname"w	DISPLAY FILE fname

**Table D-1. Escape Sequence OptiSCREEN Command - Continued**

{ESC}>z	DISPLAY FILE MEMORY
{ESC}{>nnnw	DISPLAY FILE nnn
{ESC}>97r	DISPLAY KEY TABLE
{ESC}k	DISPLAY TIME HERE
{ESC}#7	DOUBLE SIZE
{ESC}#9str{ETX}	DOUBLE SIZE "str"
{ESC}15m	DOUBLE WIDE
{ESC}#6	DOUBLE WIDE LINE
{ESC}linB	DOWN line
{ESC}=ccc;xxxi	DRAW BAR DOWN ccc X xxx
{ESC}=xxxi	DRAW BAR DOWN xxx
{ESC}=lin;xxxj	DRAW BAR LEFT lin X xxx
{ESC}=xxxj	DRAW BAR LEFT xxx
{ESC}=lin;xxxg	DRAW BAR RIGHT lin X xxx
{ESC}=xxxg	DRAW BAR RIGHT xxx
{ESC}=ccc;xxx f	DRAW BAR UP ccc X xxx
{ESC}=xxx f	DRAW BAR UP xxx
{ESC}=lin;ccce	EMPTY BOX lin X col
{ESC}>5l	ENABLECURSOR
{ESC}?14h	ENABLEDATE
{ESC}?15h	ENABLETIME
{EOT}	END
{ESC}=ccc;xxxm	ERASE BAR DOWN ccc X xxx
{ESC}=xxxm	ERASE BAR DOWN xxx
{ESC}=lin;xxxn	ERASE BAR LEFT lin X xxx
{ESC}=xxxn	ERASE BAR LEFT xxx
{ESC}=lin;xxxl	ERASE BAR RIGHT lin X xxx
{ESC}=xxxl	ERASE BAR RIGHT xxx
{ESC}=ccc;xxxk	ERASE BAR UP ccc X xxx
{ESC}=xxxk	ERASE BAR UP xxx
{ESC}13m	EXITALTERNATE
{ESC}22m	EXIT DOUBLE WIDE AND BLINK
{ESC}17m	EXIT QUAD
{ESC}10m or {SI}	EXITSUPPLEMENTAL
{ESC}=lin;ccc;bchar	FILL BOX lin X ccc WITH "char"
{ESC}<Ynnn; "name"Y	FUNCTION KEY nnn PERFORM name
{ESC}<I "name";lin;nnn;sssI	GRAPH name DOWN lin SCALE nnn TO sss
{ESC}<M "name";ccc;nnn;sssM	GRAPH name LEFT ccc SCALE nnn TO sss
{ESC}<Q "name";ccc;nnn;sssQ	GRAPH name RIGHT ccc SCALE nnn TO sss
{ESC}<G "name";lin;nnn;sssE	GRAPH name UP lin SCALE nnn TO sss
{ESC}<K "name";str{ETX};lin;nnn;sssK	GRAPH name USING "str" DOWN lin SCALE nnn TO sss
{ESC}<O "name";str{ETX};ccc;nnn;sssO	GRAPH name USING "str" LEFT ccc SCALE nnn TO sss
{ESC}<S "name";str{ETX};ccc;nnn;sssS	GRAPH name USING "str" RIGHT ccc SCALE nnn TO sss
{ESC}<G "name";str{ETX};lin;nnn;sssG	GRAPH name USING "str" UP lin SCALE nnn TO sss
{ESC}32m	GREEN
{ESC}42m	/GREEN
{ESC}<DnnnD	GROUP nnn GRAPHS
{ESC}<Dnnn;titl{ETX}D	GROUP nnn GRAPHS, TITLE "titl"
{ESC}f or {ESC}H	HOME
{ESC}=nnn;sss;qqqh	HORIZONTAL BAR GRAPH nnn, sss, qqh
{ESC}D	INDEX
{ESC}>i	INPUT PARALLELDATA

**Table D-1. Escape Sequence OptiSCREEN Command - Continued**

{ESC}L	INSERT LINE
{ESC}nnnL	INSERT nnn LINE
{ESC}<Xnnn; "name"X	KEY nnn PERFORMS name
{ESC}cccD	LEFT ccc
{ESC}36m	LIGHT BLUE
{ESC}46m	/LIGHTBLUE
{ESC}nnnf or {ESC}nnnH	LINE nnn
{ESC}>nnntstr{ETX}	LOAD FUNCTION KEY nnn WITH "str"
{ESC}>nnn;sssr	LOAD KEY nnn WITH sss
{ESC}>10nr	LOAD KEY TABLE nnn
{ESC}35m	MAGENTA
{ESC}45m	/MAGENTA
{ESC}lin;cccf or {ESC} lin;cccH	MOVE TO lin, ccc
{ESC}E	NEWLINE
{ESC}>8l	NO AUTO LINE FEED
{ESC}9l	NO AUTORETURN
{ESC}?7l	NO AUTOWRAP
{ESC}>5h	NO CURSOR
{ESC}32m	NORMAL
{ESC}42m	/NORMAL
{ESC}>nnno	OUTPUT PARALLELDATA: nnn
{ESC}>nnnp	PARALLELI/OMODE:nnn
{ESC}S	PRINTSCREEN
{ESC}nnnS	PRINT SCREEN TO PORT nnn
{ESC}nnn;sssS	PRINT SCREEN TO PORT nnn, GRAPHIC TYPE sss
{ESC}35m	PURPLE
{ESC}45m	/PURPLE
{ESC}16m	QUAD SIZE
{ESC}31m	RED
{ESC}41m	/RED
{ESC}m or {ESC}0m	RESET ATTRIBUTES
{ESC}#0	RESET LINE ATTRIBUTES
{ESC}u or {ESC}8	RESTORE POSITION
{ESC}M	REVERSE INDEX
{ESC}7m	REVERSED
{ESC}cccC	RIGHT ccc
{ESC}linE	ROW lin
{ESC}s or {ESC}7	SAVE POSITION
{ESC}=lin;cccr	SCROLL DOWN lin X ccc
{ESC}=lin;cccpl	SCROLL LEFT lin X ccc
{ESC}nnn;sssr	SCROLL LINES nnn TO sss
{ESC}=lin;cccoc	SCROLL RIGHT lin X ccc
{ESC}=lin;cccpl	SCROLL UP lin X ccc
{ESC}X	SET DEFAULT ATTRIBUTE
{ESC}#5	SINGLE SIZE LINE
{ESC}4h	START INSERT
{ESC}>11h	STEADY CURSOR
{ESC}4l	STOP INSERT
{ESC}11m or {SO}	SUPPLEMENTAL
{ESC}>dx	TRANSMIT DIR VIA PRIMARY PORT
{ESC}>dy	TRANSMIT DIR VIA SECONDARY PORT

**Table D-1. Escape Sequence OptiSCREEN Command - Continued**

{ESC}> "fname"x	TRANSMITFILE fname VIA PRIMARY PORT
{ESC}> "fname"y	TRANSMIT FILE fname VIA SECONDARY PORT
{ESC}>nnnx	TRANSMIT FILE nnn VIA PRIMARY PORT
{ESC}>nnny	TRANSMIT FILE nnn VIA SECONDARY PORT
{ESC}36m	UNDERLINE
{ESC}>4l	UNDERLINECURSOR
{ESC}linA	UP lin
{ESC}<cstr{ETX}	USEFORMAT "str"
{ESC}=nnn;sss;qqqv	VERTICAL BAR GRAPH nnn, sss, qqv
{ESC}<A "vname"A	VIEW vname
{ESC}<B "vname";stroff{ETX};stron{ETX}	VIEW vname OFF: "stroff" ON: "stron"
{ESC}<B "vname";stroff{ETX};"onfile"	VIEW vname OFF: "stroff" ON: onfile
{ESC}<B "vname";"offfile";stron{ETX}	VIEW vname OFF: offfile ON: "stron"
{ESC}<B "vname";"offfile";"onfile"	VIEW vname OFF: offfile ON: onfile
{ESC}A "vname";str{ETX}A	VIEW vname USING "str"
{ESC}37m	WHITE
{ESC}47m	/WHITE
{ESC}33m	YELLOW
{ESC}43m	/YELLOW

# Appendix E

## VT52 Escape Sequences

It is not recommended that VT52 escape sequences be used with new application software.

The first column in the following list contains the character or characters that follow the escape character, and the second contains the function of that sequence.

SEQUENCE	FUNCTION
#	Transmit Page.
/Z	Response to ESC Z (VT100 identification code for VT52).
<	Enter ANSI mode.
@	Enter insert character mode.
A	Cursor up.
B	Cursor down.
C	Cursor right.
D	Cursor left.
E	Clear screen (except status lines).
F	Enter graphics mode.
G	Exit graphics mode.
H	Move cursor to home position.
I	Reverse index (reverse scroll).
J	Erase from cursor to end of screen.
K	Erase from cursor to end of line.
L	Insert a line at cursor position.
M	Delete line at cursor position.
N	Delete character at cursor.
O	Exit insert character mode.
P	Special function key "f1" (transmitted only).
Q	Special function key "f2" (transmitted only).
R	Special function key "f3" (transmitted only).
S	Special function key "f4" (transmitted only).
T	Special function key "f5" (transmitted only).
U	Special function key "f6" (transmitted only).
V	Special function key "f7" (transmitted only).
W	Special function key "f8" (transmitted only).
Y <line#><col#>	Cursor addressing. Line and column numbers are single ASCII characters where ASCII code 32 decimal is used to designate line or column one and increase from there.
Z	Identify as VT52. Response: ESC / K.

**E**

SEQUENCE	FUNCTION
^  (underscore)	Transmit status line(s). Transmit current (cursor) line. Transmit character at cursor.
b c d e j k l n	Erase from beginning of display to cursor. Enable clock display. Disable clock display. Send time to host (Transmits HHMMSS<CR>). Save current cursor position. Restore current cursor position. Erase entire line. Cursor position report. Response: ESC Y <line #> <col #>. See cursor positioning notes above.
o p q v w x<parameter> x4 x5 x8 x9 x; x=	Erase from beginning of line to cursor. Enter reverse video mode. Exit reverse video mode. Enter wrap at end of line mode. Exit wrap at end of line mode. VT52 set modes. Set block cursor. Disable cursor. Enable auto line feed on carriage return. Enable auto carriage return on line feed. Set non-blinking cursor. Set hardware handshaking.
x> y<parameter> y4 y5 y8 y9 y; y= y> z ( )	Enable ECHO (half duplex). VT52 reset modes. Set underline cursor. Enable cursor. Disable auto line feed on carriage return. Disable auto carriage return on line feed. Set blinking cursor. Set software handshaking. Disable half duplex. Reset to power up configuration. Enable keyboard. Disable keyboard.

# Appendix *F*

## *Function Key Operations*

---

---

The 16 function keys are programmed to perform two independent functions. In Local mode, they are used as single key entries to select various character and line attributes allowing user screens to be programmed easily. In On-Line mode, they transmit the escape sequences shown for the VT52 mode or the currently programmed messages for the ANSI mode.

In the ANSI mode, the function keys transmit user-defined messages which may include other escape sequences. These messages may contain up to 16 ASCII characters. The default messages (escape sequences) for the ANSI mode or the standard VT52 messages (escape sequences) will be ignored upon receipt by the terminal.

To program new ANSI messages, the escape sequence ESC [ > n t followed by the message and terminated with ETX (Control-C) is used. This escape sequence can be entered while in Local mode or On-Line mode. The terminal will truncate any programmed messages at 16 characters, and will fill any unused character locations up to 16 with NULLs. These escape sequences may be programmed as part of a screen file.

In On-Line mode, the function keys are not preprogrammed.

In Local mode, the function keys have been preprogrammed to perform specific tasks. These are as follows:

- f1 = Reset to normal video display (resets attributes marked with \*).
- f2 = Select foreground intensity/color \*.
- f3 = Select background intensity/color \*.
- f4 = Terminate an f2 or f3 selection.
- f5 = Enter blink video \*.
- f6 = Enter reverse video \*.
- f7 = Enter double wide character mode \*.
- f8 = Exit blink and/or double wide mode.
- f9 = Enter quad size character mode.
- f10 = Exit quad size character mode.
- f11 = Set line to double high tops & double wide.
- f12 = Set line to double high bottoms & double wide.
- f13 = Set line to single high & single wide.
- f14 = Enter alternate character set (96 graphics).
- f15 = Exit alternate character set (96 graphics).
- f16 = Clear all attributes -  
Includes video attributes and line attributes.  
Exits alternate character set.  
Exits supplemental graphics.  
Exits quad size characters.

The function keys f2 and f3 are used in a sequence such as f2 n f4 or f3 n f4. These keys allow any combination of foreground and background intensities to be combined. They are also designed to be upward compatible with color models of the terminal. The parameter n yields the effect shown in the following table.

<b>n</b>	<b>MONOCHROME</b>	<b>COLOR</b>	<b>NOTES</b>
0	Hidden(Black)	Black	Default background
1	Dim	Red	
2	Normal	Green	Default foreground
3	Highlight	Yellow	
4	----	Blue	
5	Underline & Dim	Pink	
6	Underline & Normal	Turquoise	
7	Underline & Highlight	White	

### Note

Underline is a foreground attribute only.

The attribute “shade” described earlier is the combination of a dim background and highlight foreground. It can be achieved using the sequence: f2 3 f4 followed by f3 1 f4. Obviously many other versions of shade can be created using the above parameters. Reverse in monochrome automatically switches the foreground and background intensities. In the color mode, reverse will only switch parameters 0 to 3.

# Appendix G

## STR-LINK III Communications Protocol

Experienced programmers may wish to use a personal computer or other device to back up user memory instead of a STR-LINK III Digital Cartridge Recorder. The following outline shows the protocol used by the OIT during Save, Load, and Verify operations.

STEP	OIT TRANSMITS		STR-LINK III	TRANSMITS
1	DC1 (11H)	Reader On	ACK (06H) UserMemory *	Acknowledge
2				
3				
4	DC3 (13H)	Reader Off	ACK (06H)	Acknowledge
5				
6	EOT (04H)	Rewind	ACK (06H)	Acknowledge
7				

\* For releases prior to 2.0, one character per byte of memory is transmitted. (If 16K memory, then 16,384 characters will be sent).

For releases 2.0 and later, a 4-byte header is transmitted for each memory block used, plus the characters, plus a zero at the end of all data. The 4-byte header for each memory block includes the following:

- Byte 1: # of K-bytes in memory block (in packed BCD format).
- Byte 2 & 3: # of bytes in memory block (in binary).
- Byte 4: Memory block type code (in binary).

The Memory block type code is as follows:

- Block type 0 = Screen memory.
- Block type 1 = Basic program memory.
- Block type 2 = Basic data memory.
- Block type 3 = Back-up screen memory.
- Block type 4 = Back-up program memory.
- Block type 5 = To be defined.

STEP	OIT TRANSMITS		STR-LINK III	TRANSMITS
1	DC2 (12H)	Punch On		
2			ACK (06H)	Acknowledge
3	SO (0EH)	Shift out		
4	UserMemory *			
5	SI (0FH)	Shift in		
6	DC4 (14H)	Punch Off		
7			ACK (06H)	Acknowledge
8	EOT (04H)	Rewind		
9			ACK (06H)	Acknowledge

\*If 16K memory, then 16,384 characters will be sent.

A 250ms delay prior to step 5 (SI) is used to differentiate this as a valid command from possible data equal to 0FH.

**A**

AC Power, 3-2

Alphabetic Keys, 4-21

ALTERNATE {ESC}[12m, EXit ALTER-NATE {ESC}[13m, 5-11

Alternate Graphics Set, B-8

ANSI X3.64, 1-13

Apostrophe (') Comment, 5-3

ASCII Codes and Characters, B-1

Attaching the Keyboard, 2-2

ATTRIBUTE Command for all OITs, 5-16

Attributes for Both Color and Monochrome OITs, 5-9

Attributes for Color OITs Only, 5-13

Attributes for Monochrome OITs Only, 5-15

ATTRIBUTES: nn, nn {ESC} nnn; nnn m, ATTRIBUTES: nn, nn, nn {ESC} nnn; nnn; nnn m, 5-17

AUTO LINE FEED ON RETURN {ESC}[>8h, NO AUTO LINE FEED {ESC}[>81, 5-4

AUTO RETURN ON LINE FEED {ESC}[9h, NO AUTO RETURN {ESC}[91, 5-4

AUTO WRAP AT END OF LINE {ESC}[?7h, NO AUTO WRAP {ESC}[?71, 5-4

**B**

BASIC Menu, 4-7

BASIC Menu - [F5] from the Main Function Bar, 4-7

Battery Replacement, 3-4

BAUD nnn {ESC}[ nnn W, 5-4

Baud Rate, 4-19

Bell Output Wiring, 3-3

Bit Control, 7 or 8, 4-17

BLACK {ESC}[30m, /BLACK {ESC}[40m, 5-13

BLINK {ESC}[5m, EXIT DOUBLE WIDE AND BLINK {ESC}[22m, 5-9

BLINKING CURSOR {ESC}[>11l, STEADY CURSOR {ESC}[>11h, 5-5

BLOCK CURSOR {ESC}[>4h, UNDER-LINE CURSOR {ESC}[>41, 5-5

BLUE {ESC}[34m, /BLUR {ESC}[44M, 5-14

BOX ATTRIBUTES rr X cc {ESC}[= rrr; ccc a, 5-32

BOX rr X cc {ESC}[= rrr; ccc d, 5-30

BRIGHT {ESC}[33m, /BRIGHT {ESC}[43m, 5-15

**C**

Cable and Connector Specifications, 3-9

Cable Wiring Configurations, 3-10

Calling a Screen File from Another Screen File, 2-15

Case Sensitivity, 4-15

Changing a Screen File from Absolute to Relative, 2-14

Character Attribute, 5-1

Character Attribute Commands, 5-8

CLEAR KEY TABLE {ESC}[>98r, 5-38

CLEAR LINE {ESC}[2K, 5-22

CLEAR LINE FROM CURSOR {ESC}[0K, 5-22

CLEAR LINE TO CURSOR {ESC}[1K, 5-23

CLEAR SCREEN {ESC}[2J, 5-21

CLEAR SCREEN FROM CURSOR {ESC}[0J, 5-21

CLEAR SCREEN TO CURSOR {ESC}[1J, 5-22

CLEARSTATUS LINE {ESC}[3J, 5-23

Clearing the Screen, 5-21

Clock and Date, 5-1

Clock and Date Commands, 5-19

Color Controls, 4-17

COMMAND FORM {ESC}xxx, 5-3

Command Summary, 5-54

Comment and End of File, 5-1  
Comment Command and the End of File Command, 5-3  
Communication Interface, 3-5  
Communication Type, 4-19  
Communications Parameters, 4-19  
Comparison of Various Character Attribute Modes, 5-12  
Confidence Tests, 4-20  
CONFIG Menu, 4-13  
CONFIG Menu - [F7] from the Main Function Bar, 4-13  
Configuration, 5-1  
Configuration Commands, 5-4  
Configuration Options, 4-14  
Configuration Procedure, 4-14  
Configuring the OIT, 3-13  
Connecting the OIT to a Series 90-70 or Series 90-30 PCM Module, 1-6  
Control Keys, 4-24  
Controlling the Appearance of the Cursor, 5-5  
Controlling the Location of the Cursor, 5-5  
Conventions for the OptiSCREEN Commands, 5-3  
Creating a Graphic Screen, 2-13  
Creating a Text Screen File, 2-9  
Creating the Screen Format, 1-5  
CRT Adjustment, 3-21  
Cursor, 5-1  
CURSOR or ENABLE CURSOR {ESC}[>5l, NO CURSOR or DISABLE CURSOR {ESC}[>5h, 5-5  
Cursor Commands, 5-5  
Cursor Keys, 4-22  
Cursor Type, 4-17  
CYAN or LIGHT BLUE {ESC}[36m, /CYAN or /LIGHTBLUE {ESC}[46m, 5-14

## D

DARK {ESC}[30m, /DARK {ESC}[40m, 5-16  
Data Fill Operations, 5-2, 5-52  
  Example Data Fill Operation, 5-52  
Data Transmissions and Port Control, 5-2  
Data Transmissions and Port Control Commands, 5-43  
DEFAULT KEY TABLE {ESC}[>99r, 5-39  
DELETE CHARACTER {ESC}[P, DELETE nn CHARACTERS {ESC}[ nnn P, 5-26  
DELETE LINE {ESC}[M, DELETE nn LINES {ESC}[ nnn M, 5-23  
DIM {ESC}[31m, /DIM {ESC}[41m, 5-15  
DISABLE DATE {ESC}[?14l, ENABLE DATE {ESC}[?14h, 5-19  
DISABLE TIME {ESC}[?15l, ENABLE TIME {ESC}[?15h, 5-19  
Display, 5-2  
Display and File Display Commands, 5-20  
DISPLAY DATE HERE, 5-20  
DISPLAY DIRECTORY {ESC}[dw, 5-21  
DISPLAY FILE MEMORY {ESC}[>z, 5-21  
DISPLAY FILE nn {ESC}[> nnn w, 5-21  
DISPLAY KEY TABLE {ESC}[>97r, 5-39  
DISPLAY TIME HERE, 5-20  
DOUBLE SIZE {ESC}#7, DOUBLE SIZE "text" {ESC}#9"test"{ETX}, 5-18  
DOUBLE WIDE {ESC}[15m, EXIT DOUBLE WIDE AND BLINK {ESC}[22m, 5-11  
DOUBLE WIDE LINE {ESC}#6, 5-18  
DOWN {ESC}[B, DOWN nn {ESC}[ nnn B, 5-6  
DRAW BAR direction pp {ESC}[= ppp i, DRAW BAR direction cc X pp {ESC}[= ccc;ppp i, 5-36  
Drawing Bar Graphs, 5-33

## E

Echoing, 4-15  
EMPTY BOX rr X cc {ESC}[= rrr; ccc e, 5-31

END {EOT}, 5-3  
 End of Line Controls, 4-16  
 ERASE BAR direction pp {ESC}[= ppp i,  
 ERASE BAR direction cc X pp  
 {ESC}[= cc;ppp i, 5-24  
 Erasing and Editing, 5-2  
 Erasing and Editing Commands, 5-21  
 Example Data Fill Operation, 5-52

## **F**

Feature Comparison Between OIT Mod-  
 els, 1-3  
 Feature Comparison of OIT Models, 1-3  
 Features of the OIT, 1-2  
 File Display, 5-2  
 FILL BOX rr X cc WITH "a" {ESC} rrr;  
 ccc b a, 5-31  
 FUNCTION KEY nn PERFORMS file, 5-42  
 Function Keys, 4-22

## **G**

General Operation of the OIT, 1-4  
 Generating Boxes and Boxed Regions,  
 5-30  
 GRAPH item direction, 5-44  
 GRAPH item TITLE, 5-44  
 GRAPH item USING, 5-44  
 Graphics, 5-2  
 Graphics Commands, 5-29  
 GREEN {ESC}[32m, /GREEN  
 {ESC}[42m, 5-14  
 GROUP nn GRAPHS, 5-50

## **H**

Handshaking, 4-19  
 Handshaking with RS-232C Signals, 3-7  
 Handshaking with RS-422 Signals, 3-8  
 HOME {ESC}[H or {ESC}[f, 5-5

HORIZONTAL BAR GRAPH nn, ff, mm  
 {ESC}[= nnn; fff; mmm h, 5-33  
 How Multidrop Operation Works, 3-17  
 How the Dynamic Data is Produced, 1-4

## **I**

IBM PC-compatible Keyboards, 1-11  
 INDEX {ESC}D, 5-8  
 INSERT LINE {ESC}[L, INSERT nn  
 LINES {ESC}[ nnn L, 5-26  
 Inserting Text, 5-26  
 Installation, 6-1  
 Installing Memory and Logic Board Jump-  
 ers, 3-18  
 Installing the AC Power, 2-1  
 Installing the Battery, 2-1  
 Introduction, 6-1  
 IWS.BAT – Start-Up Program, 6-2  
 IWSDOC – Documentation Program, 6-3  
 IWSEEDIT – Screen Editor, 6-3  
 IWSLINK – STRLINK III Emulation, 6-3

## **J**

Jumpers, 3-18, 3-20  
 Logic Board, 3-18  
 Main Menu, 4-3  
 Memory, 3-18

## **K**

KEY mmm PERFORMS file, 5-42  
 Keyboard Control, 4-18  
 Keyboard Operation, 4-21  
 Keyboard, 34-position, 1-10  
 Keyboard, 65-position, 1-8  
 Keyboards for the OIT, 1-8

## **L**

LEFT {ESC}[D, LEFT nn {ESC}[ nnn D,  
 5-7

Line Attribute, 5-1  
Line Attribute Commands, 5-18  
LINE rr {ESC}[ rrr f or {ESC}[ rrr H, 5-8  
LOAD FUNCTION KEY nn WITH “text”  
{ESC} nnn t text {ETX}, 5-42  
LOAD KEY nn WITH vvv {ESC} nnn; k  
r, 5-40  
LOAD KEY TABLE nn {ESC}]>10n r,  
5-42  
Loading Utility Programs Without Resi-  
dent DOS and BASICA, 6-2  
LOCAL Item - [F9] from the Main Func-  
tion Bar, 4-21  
Logic Board Jumpers, 3-18

## M

MAGENTA or PURPLE {ESC}[35m,  
/MAGNETA or PURPLE {ESC}[45m,  
5-14  
Main Function Bar, 4-3  
Main Menu - The Main Function Bar, 4-3  
Memory, 3-18  
Memory Jumpers, 3-18  
Miscellaneous Keys, 4-23  
Mode, 4-15  
Mounting the OIT, 3-1  
MOVE TO rr, {ESC}[ rrr f, MOVE TO rr,  
cc {ESC}[rrr;ccc f or {ESC}[rrr;ccc H,  
5-6  
Multidrop Operations, 3-13

## N

NEW LINE {ESC}E, 5-8  
Nonalphabetic Keys, 4-22  
NORMAL {ESC}[32m, /NORMAL  
{ESC}[42m, 5-16  
Now That You’ve Started, 2-20  
Number of Status Lines, 4-17

## O

OIT – Main Utility Menu, 6-2  
OIT Compatibility, 1-13  
ONLINE Item - [F8] from the Main Func-  
tion Bar, 4-21  
OptiSCREEN Command Types, 5-1

## P

Parity, 4-19  
Port Connector Definitions, 3-6  
Powering-up the OIT, 2-2  
Primary Port, 3-8  
Print Screen Control, 4-17  
PRINT SCREEN TO PORT n, PRINT  
SCREEN TO PORT n, GRAPHIC  
TYPE g {ESC}[ nnn;ggg S, 5-43  
Programmable Keyboard and Function  
Key, 5-2  
Programmable Keyboard and Function  
Key Commands, 5-38  
Programmable Keyboard Programming,  
5-38

## Q

QUAD SIZE {ESC}[16m, EXIT QUAD  
{ESC}[17m, 5-10  
Quad Size Character Set, B-12

## R

Rear Panel Connections, 3-2  
RED {ESC}[31m, /RED {ESC}[41m, 5-14  
Reset Input Wiring, 3-4  
RESET LINE ATTRIBUTES {ESC}#0,  
5-19  
REVERSE INDEX {ESC}M, 5-8  
REVERSED {ESC}[7m, 5-9  
RIGHT {ESC}[C, RIGHT nn {ESC}[ nnn  
C, 5-7  
RUN Item - [F10] from the Main Function  
Bar, 4-21

**S**

Sample Program, 2-17  
 Sample Screen, Format, 2-17  
 SAVE POSITION {ESC}7 or {ESC}{s},  
 RESTORE POSITION {ESC}8 or  
 {ESC}{u}, 5-8  
 Screen Control, 4-17  
 SCREEN Menu - [F2] from the Main Func-  
 tion Bar, 4-5  
 SCROLL direction rr X cc {ESC}[= rrr;  
 ccc q, 5-29  
 SCROLL LINES nn TO pp {ESC}[ nnn;  
 ppp r, 5-28  
 Scrolling, 5-28  
 Secondary Port, 3-8  
 Selecting the Programmable Keyboard,  
 5-38  
 Set and Display the Date and Time, 4-16  
 SETUP Menu, 4-4  
 SETUP Menu - [F1] from the Main Func-  
 tion Bar, 4-4  
 SINGLE SIZE LINE {ESC}#5, 5-19  
 Specifications, 1-12  
 START INSERT {ESC}[4h, STOP INSERT  
 {ESC}[4l, 5-27  
 Stop Bits, 4-19  
 STOP INSERT {ESC}[4l, 5-30  
 SUPPLEMENTAL {ESC}[11m or  
 {SO}>, EXIT SUPPLEMENTAL  
 {ESC}[10m or {S1}, 5-9  
 Supplemental Alternate Graphics Set,  
 B-11  
 Supplemental Standard Graphics Set, B-6

**T**

text textDISPLAY "text" text, 5-20  
 TOOLS Menu - [F6] from the Main Func-  
 tion Bar, 4-8  
 TOOLS Menus, 4-8  
 Transferring Data Between the Host  
 (PLC) and the OIT, 1-6

TRANSMIT DIRECTORY VIA position  
 PORT, 5-43  
 TRANSMIT FILE fname VIA position  
 PORT, 5-43  
 Turning the OIT On, 4-2  
 Typical Cable Wiring Configurations, 3-10

**U**

UNDERLINE {ESC}[36m, BRIGHT UN-  
 DERLINE {ESC}[37r, 5-16  
 UNDERLINE {ESC}[36m, DIM UNDER-  
 LINE {ESC}[35m, 5-16  
 UP {ESC}[A, UP nn {ESC}[ nnn A, 5-7  
 USE FORMAT "format-string" {ESC}[  
 nnn A, 5-50  
 User-Customized Keyboards, 1-11  
 Using the Configuration Menu, 2-6  
 Using the Menu-driven System, 2-4  
 Using the OptiSCREEN Editor, 2-8

**V**

VERTICAL BAR GRAPH nn, ff, mm  
 {ESC}[= nnn; fff; mmm v, 5-35  
 VIEW Commands, 5-2 , 5-43  
 VIEW item, 5-47  
 View item OFF, 5-48  
 VIEW item USING, 5-47  
 VT100, 1-13  
 VT52, 1-13

**W**

WHITE {ESC}[37m, /WHITE  
 {ESC}[47m, 5-14  
 Wiring for RS-422 Communications, 3-13  
 Word Length, 4-19

**Y**

YELLOW {ESC}[33m, /YELLOW  
 {ESC}[43m, 5-15