

GFK-1857
New In Stock!
GE Fanuc Manuals

<http://www.pdfsupply.com/automation/ge-fanuc-manuals/operator-interface/GFK-1857>

operator-interface
1-919-535-3180

QuickPanel Family Hardware Reference Manual

www.pdfsupply.com

Email: sales@pdfsupply.com

QUICKPANEL FAMILY

Product Identification

Below is a list of currently available *QUICKPANEL* family models and option modules.

QUICKPANEL jr.

QPJ-2D100-L2P	5" Monochrome LCD
QPJ-2D100-S2P	5" STN Color LCD
QPK-2D100-L2P	6" Monochrome LCD
QPK-2D100-S2P	6" STN Color LCD
QPK-3D200-C2P	6" TFT Color LCD
QPM-2D100-L2P	6" Monochrome LCD (Mini)

QUICKPANEL

	<u>Display Type</u>
QPI-21100-E2P	9" Monochrome EL, 120VAC
QPI-31200-E2P(1)	(Replaces QPI-21100-E2P)
QPI-21100-S2P	10.5" STN Color LCD, 120VAC
QPI-31200-S2P(1)	(Replaces QPI-21100-S2P)
QPI-21100-C2P	10.5" TFT Color, 120VAC
QPI-31200-C2P(1)	(Replaces QPI-21100-C2P)
QPI-2D100-L2P	10.5" Monochrome LCD, 24VDC
QPI-2D100-E2P	9" Monochrome EL, 24VDC
QPI-3D200-E2P (1)	(Replaces QPI-2D100-E2P)
QPI-2D100-S2P	10.5" Color STN, 24VDC
QPI-2D100-C2P	10.5" TFT Color, 24VDC
QPI-3D200-C2P(1)	(Replaces QPI-2D100-C2P)
QPL-21100-C2P	12.1 TFT Color, 120VAC
QPL-2D200-C2P	12.1 TFT Color, 24VDC

Note 1: QPI-3xxxx Series supports 64 Colors, 2Mbyte application memory, twice the brightness of QPI-2xxxx series, and 100MHz processor.

Option Module

QPI-ABR-201
QPI-ABD-201
QPI-COS-201
QPI-DVN-202
QPI-GEG-201
QPI-IBS-201
QPI-MBP-201
QPI-PBS-202
QPJ-ABR-201
QPJ-ABD-201
QPJ-GEG-201
QPJ-MBP-201
QPJ-PBS-201
QPJ-IBS-201
QPJ-COS-201
QPJ-DVN-202

Protocol Selection

QUICKPANEL A-B 1771Remote I/O
QUICKPANEL A-B Data Highway Plus
QUICKPANEL CANopen
QUICKPANEL Device Net Slave
QUICKPANEL General Electric Genius I/O
QUICKPANEL Interbus S Slave
QUICKPANEL Modicon Modbus Plus
QUICKPANEL Profibus DP Slave
QUICKPANEL jr. A-B 1771Remote I/O
QUICKPANEL jr. A-B Data Highway Plus
QUICKPANEL jr. General Electric Genius I/O
QUICKPANEL jr. Modicon Modbus Plus
QUICKPANEL jr. Profibus Module
QUICKPANEL jr. Interbus-S Module
QUICKPANEL jr. CANopen Module
QUICKPANEL jr. DeviceNet Module

NOTE

The product label contains the model number and serial number. Option modules for the *QUICKPANEL* will have a separate product label.

Installation Hints

NOTE

Mounting brackets are packed inside the carton.



CAUTION

In order to protect the unit, to provide accessibility in operation, and to improve ventilation, please ensure that there is adequate space around the unit. The recommended clearance is 4" from other structures.

Ensure that this unit is located as far away as possible from electromagnetic circuits, circuit breakers, and other equipment that causes arcing.

This unit is held in place by metal clamps. The panel thickness should be .062" (1.6mm) to .3937" (10mm).

Forced air cooling is required if this unit is to be used in a surrounding temperature which is greater than 50°C.

Route all signal lines in a separate duct, away from power circuits. Use shielded cable and tie the shield to the Frame Ground contact point.

This unit must be installed vertically for natural air cooling. Please ensure that heat from other equipment does not add heat to this unit.

Do not hit the touch panel with a hard or heavy object, or press the touch panel with too much force.

Do not use paint thinner or organic solvents to clean the unit or display.

12.1" QUICKPANEL COLOR

Dimensions for 12.1" QUICKPANEL Color Display

The dimensions shown below are for the following displays:
QPL-21100-C2P

The following drawing illustrates the overall dimensions of the 12.1" QUICKPANEL Color display.

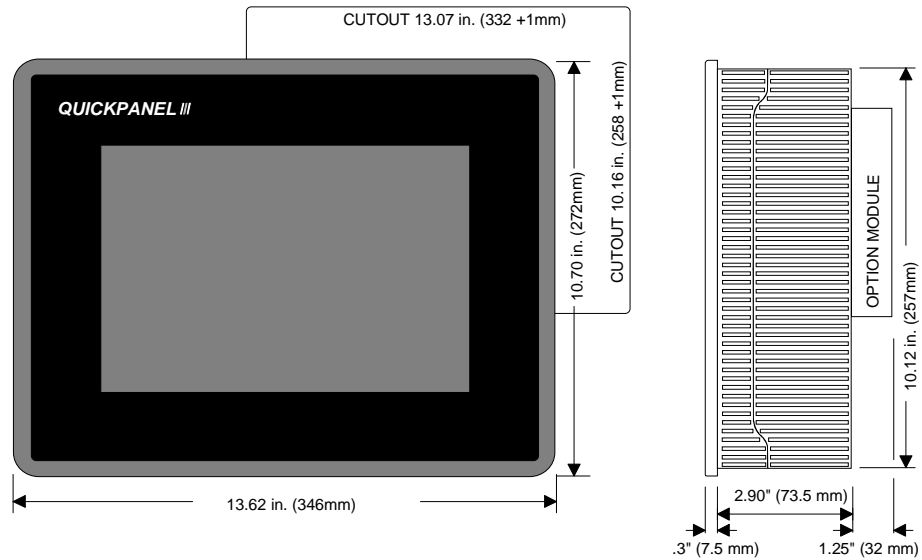

Panel Installation for 12.1" QUICKPANEL Color Units

To install the color unit, cut a hole in your panel as shown in the dimension drawing. Install the gasket to the edge of the display. Insert the display in the panel and install the four clamps in the display body. Tighten the clamps to compress the gasket and secure the unit to the panel.

The panel cutout for the 12.1" QUICKPANEL Color display is shown below. Panel thickness is 1.6mm ~ 10mm.

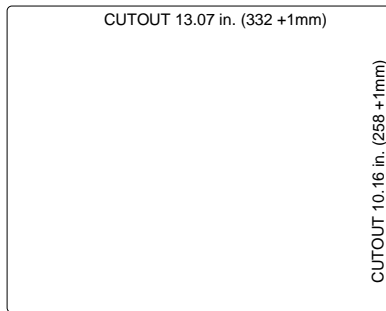

The O-ring gasket is secured to the display body by pressing it into the slot provided. The following drawing shows how the gasket is secured to the display. The replacement gasket part number is HMI-ORG-205.

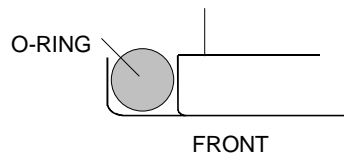

Insert the display through the panel opening and install the panel clamps. The panel clamps are inserted into the openings in the top and bottom of the panel body. The clamp screw is turned clockwise to tighten the display to the panel.

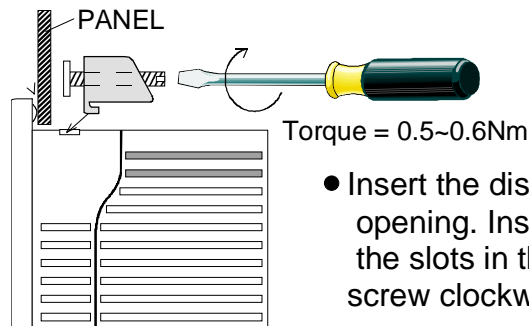

- Insert the display through the panel opening. Insert the panel clamps into the slots in the display body. Turn screw clockwise to tighten.

Rear View of the 12.1" Color Unit

The download port is used to download files from your computer to the target display. The port is also used for printing only alarm messages.

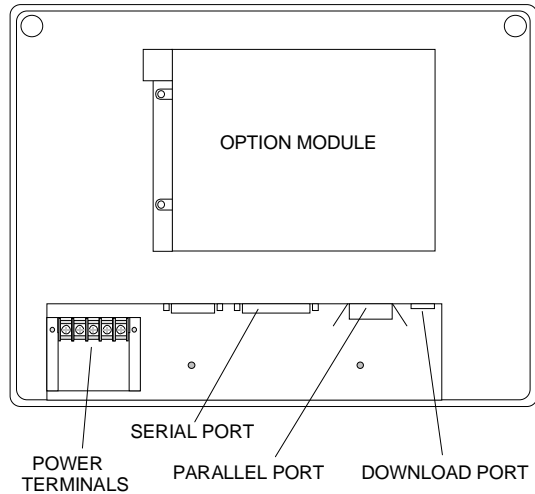

Installing AC Power to the 12.1" Color Display

This section describes installing power to the following displays:
QPL-21100-C2P

Remove the protective cover on the AC terminal strip. Remove approximately 1/4" of insulation from the supply wires and insert them under the terminal clamps. Tighten the clamp screws to secure the wires. Replace the protective cover on the AC terminal strip.

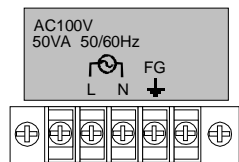

Powerup Sequence for the 12.1" Color Display

The powerup sequence is a series of operations initiated by the internal electronic circuits when power becomes stable. Stable power is indicated by an LED on the front panel.

The information displayed after power becomes stable depends on several variables. Factory units display a message indicating a device executable must be downloaded. Units that may have been setup by a distributor might indicate a PLC protocol has been loaded. Follow the procedures in the QUICKDESIGNER user manual for downloading application and device executable files.

10.5" QUICKPANEL COLOR/LCD

Dimensions for 10.5" QUICKPANEL Color/LCD Displays

The dimensions shown below are for the following displays:

QPI-2xxxx-Sxx, QPI-2xxxx-Cxx, QPI-2xxxx-Lxx

QPI-3xxxx-Sxx, QPI-3xxxx-Cxx

The following drawing illustrates the overall dimensions of the QUICKPANEL 10.5" Color/LCD display.

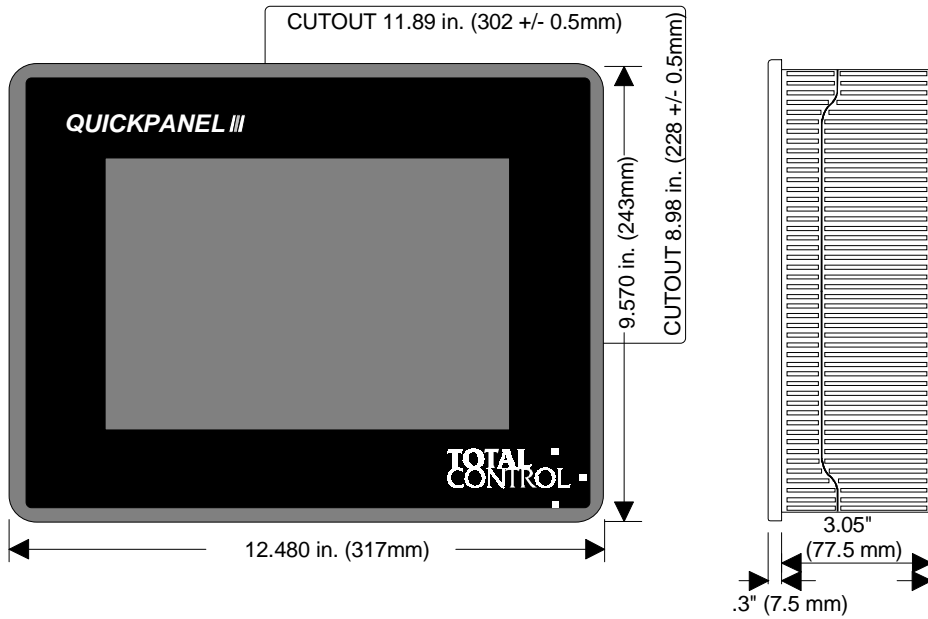

Rear View of the 10.5" Color/LCD Unit

The download port is used to download files from your computer to the target display. The port is also used for printing only alarm messages.

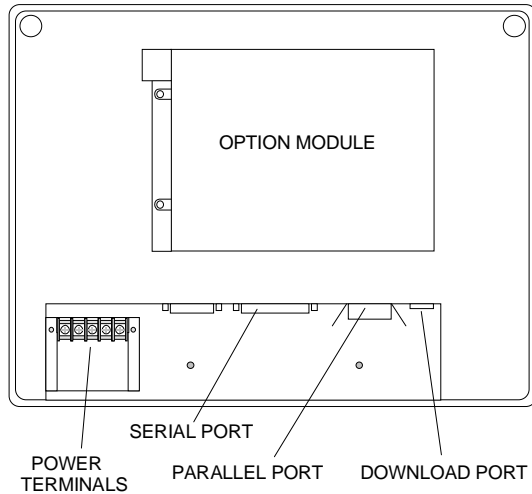

Installing AC Power to the 10.5" Color Display

This section describes installing power to the following displays:
QPI-21100-S2P and QPI-21100-C2P

Remove the protective cover on the AC terminal strip. Remove approximately 1/4" of insulation from the supply wires and insert them under the terminal clamps. Tighten the clamp screws to secure the wires. Replace the protective cover on the AC terminal strip.

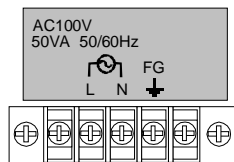

Installing DC Power to the 10.5" LCD Display

This section describes installing power to the following displays:
QPI-2D100-L2P

Remove the protective cover on the DC terminal strip. Remove approximately 1/4" of insulation from the supply wires and insert them under the terminal clamps. Tighten the clamp screws to secure the wires. Replace the protective cover on the DC terminal strip.

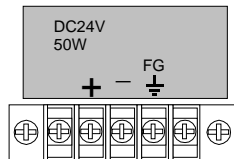

Powerup Sequence for the 10.5" Color/LCD Display

The powerup sequence is a series of operations initiated by the internal electronic circuits when power becomes stable. Stable power is indicated by an LED on the front panel.

The information displayed after power becomes stable depends on several variables. Factory units display a message indicating a device executable must be downloaded. Units that may have been setup by a distributor might indicate a PLC protocol has been loaded. Follow the procedures in the QUICKDESIGNER user manual for downloading application and device executable files.

QUICKPANEL EL

Dimensions for the 9" EL Display

The dimensions shown below are for the following displays:
QPI-21100-E2P, QPI-2D100-E2P

The following drawing illustrates the overall dimensions of the 9" QUICKPANEL Electroluminescent (EL) display.

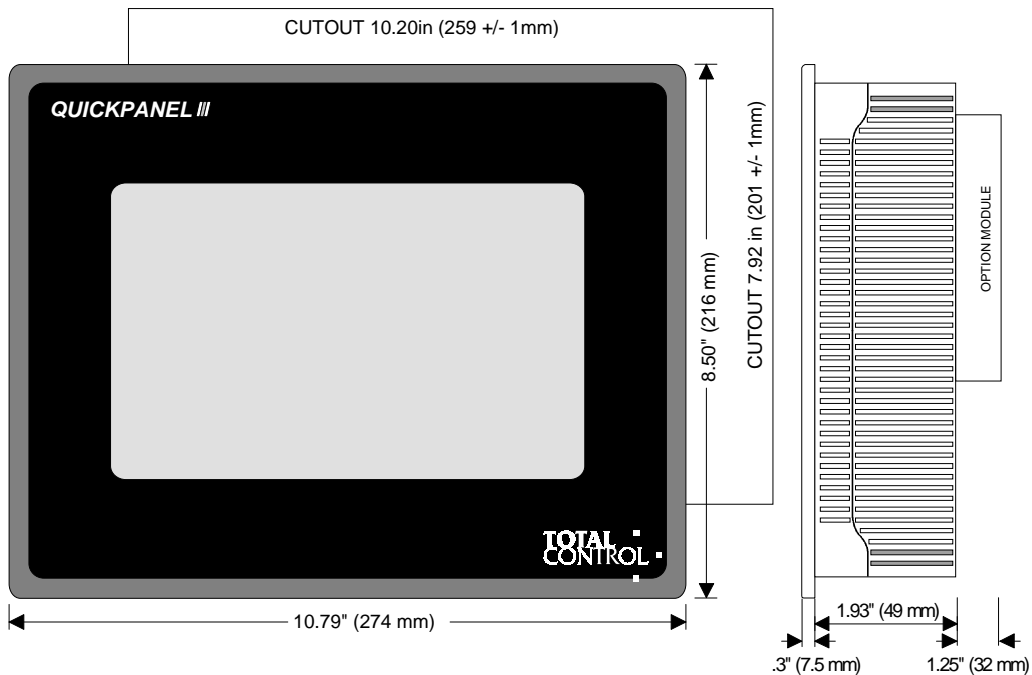

Panel Installation for 9" EL Units

To install the EL unit, cut a hole in your panel as shown in the dimension drawing. Install the O-ring gasket in the slot around the edge of the display. Insert the display in the panel and install four clamps to the display body. Tighten the clamps to compress the gasket and secure the unit to the panel.

The panel cutout for the QUICKPANEL EL display is shown below.

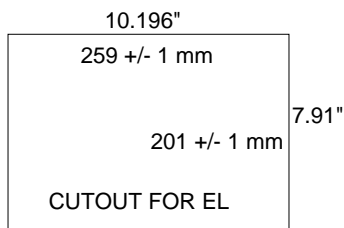

The O-ring gasket is secured to the display body by pressing it into the slot provided. The following drawing shows how the gasket is secured to the display.

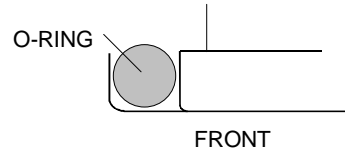

Insert the display through the panel opening and install the panel clamps. The clamp screws are turned clockwise to tighten the display to the panel. The fastening torque necessary for waterproofing is 0.5 ~ 0.6Nm.

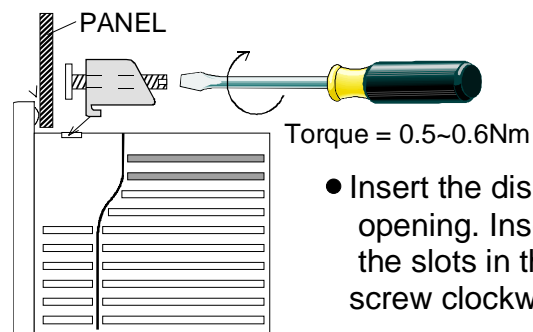

- Insert the display through the panel opening. Insert the panel clamps into the slots in the display body. Turn screw clockwise to tighten.

Rear View of the 9" EL Unit

The download port is used to download files from your computer to the target display. The port is also used for printing only alarm messages.

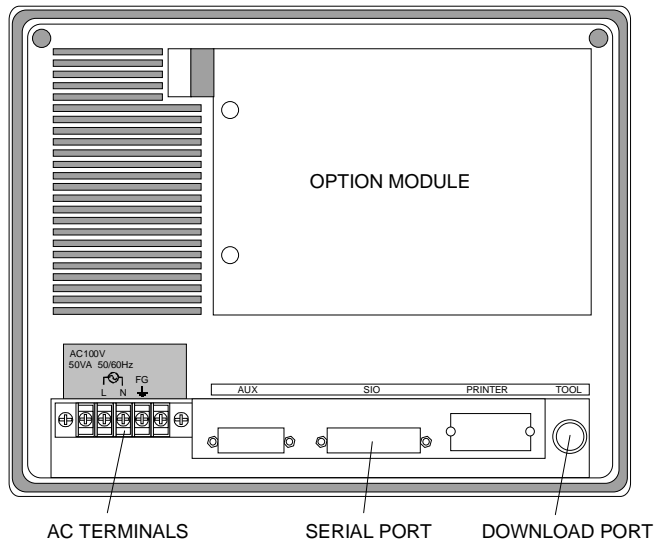

Installing AC Power for the 9" EL Display

Remove the protective cover on the AC terminal strip. Remove approximately 1/4" of insulation from the supply wires and insert them under the terminal clamps. Tighten the clamp screws to secure the wires. Replace the protective cover on the AC terminal strip.

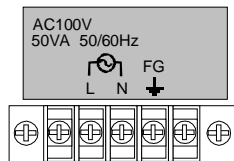

Powerup Sequence for the 9" EL Display

The powerup sequence is a series of operations initiated by the internal electronic circuits when power becomes stable. Stable power is indicated by an LED on the front panel.

The information displayed after power becomes stable depends on several variables. Factory units display a message indicating a device executable must be downloaded. Units that may have been setup by a distributor might indicate a PLC protocol has been loaded. Follow the procedures in the QUICKDESIGNER user manual for downloading application and device executable files.

QUICKPANEL jr.

Dimensions

The following drawings show the overall dimensions of the 5" and 6" QUICKPANEL jr. displays.

QuickPanel jr. 5" Display (QPJ-2xxxx-Lxx, QPJ-2xxxx-Sxx)

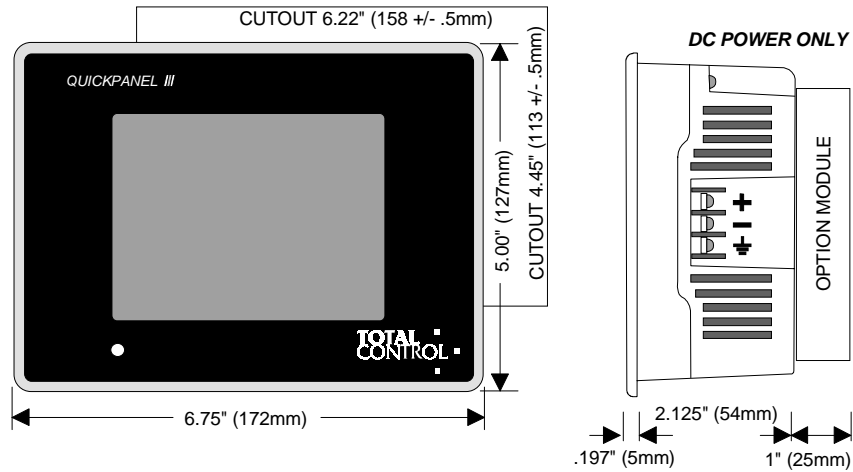

QuickPanel jr. 6" Display (QPK-2xxxx-Lxx, QPK-2xxxx-Sxx, QPK-3xxxx-Cxx)

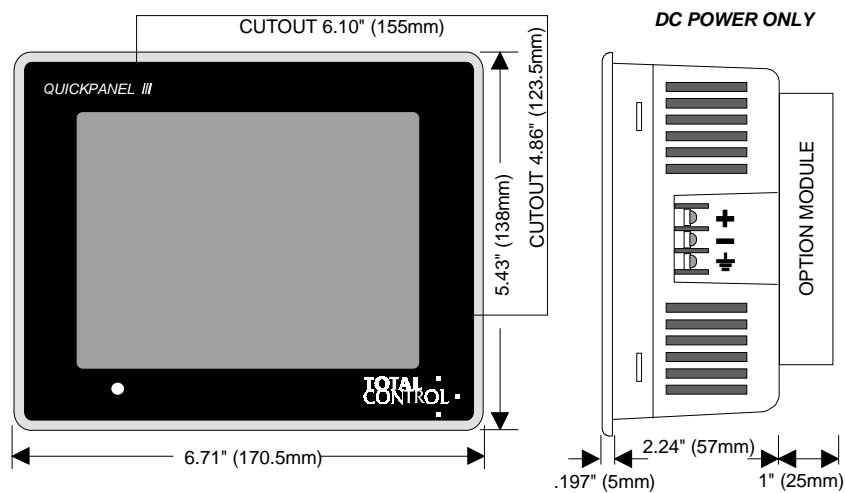

Panel Installation

The QUICKPANEL jr. display is secured to the panel with pressure clamps on the top and bottom of the display.

Make the panel cutout as shown in the drawing.

The O-ring gasket is secured to the display body by pressing it into the slot provided. The following drawing shows how the gasket is secured to the display.

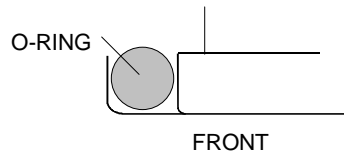

Insert the display through the panel opening and install the panel clamps. The clamp screws are turned clockwise to tighten the display to the panel. The fastening torque necessary for waterproofing is 0.5 ~ 0.6Nm.

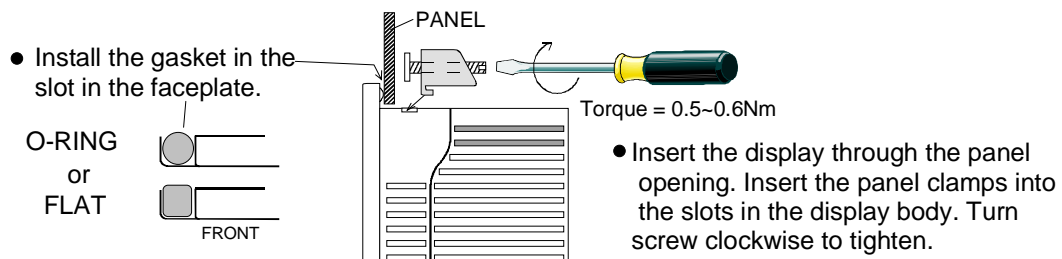

Rear View

The following drawing shows a rear view of the QUICKPANEL jr. Please note the model and serial number printed on the product label.

- The terminal strip provides quick power and ground connections to the unit. Observe the polarity for the +24VDC supply lines.
- The serial interface port connects the *QUICKPANEL jr.* to your PLC.
- The download port connects the *QUICKPANEL jr.* to your computer for downloading application files.
- The product label contains the model number and serial number of the unit.

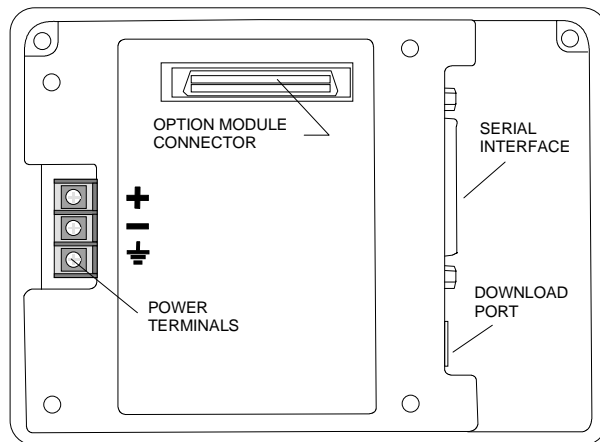

Installing 24VDC Power

Remove approximately 1/4" of insulation from the supply wire and insert it under the terminal clamp. Tighten the terminal clamp screw to secure the wire. Add a frame ground wire to the terminal marked FG. Replace the cover.

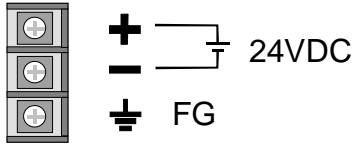

NOTE

Power source must be able to deliver 12 Watts (500 ma @ 24V) for Monochrome units and 15 Watts (625 ma @ 24V) for Color units.

Powerup Sequence

The powerup sequence is a series of operations initiated by the internal electronic circuits when power becomes stable. Stable power is indicated by an LED on the front panel.

When the power is applied, the internal circuit waits for power to stabilize then start a powerup sequence. New units do not have any projects loaded into them and may display a startup message.

To operate the unit, you must download a PLC protocol and one or more panels contained in a project file. To download a file, see the QUICKCOURIER section of the user manual.

If you received a demo unit from a dealer or distributor, it may already have a project installed. If the protocol does not match your PLC protocol, you **MUST** download a new display device executable file containing the correct PLC protocol. To download a new protocol, see the QUICKCOURIER section of the user manual.

The 6" TFT has an LED that turns green when power is applied. When the backlight CCFL tube eventually fails, the power indicator on the front of the unit turns orange and the touch screen is disabled.

QuickPanel Mini

DC Power (QPM-2Dxxx-xxx)

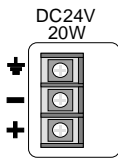

MAKE SURE THE POWER IS OFF

- Remove the protective cover on the DC terminal strip. Remove 1/4" of insulation from the supply wires and insert them under the terminal clamps. Tighten the clamp screws to secure the wires. Replace the protective cover.

Stable power is indicated by an LED on the front panel.

QUICKPANEL mini Dimensions

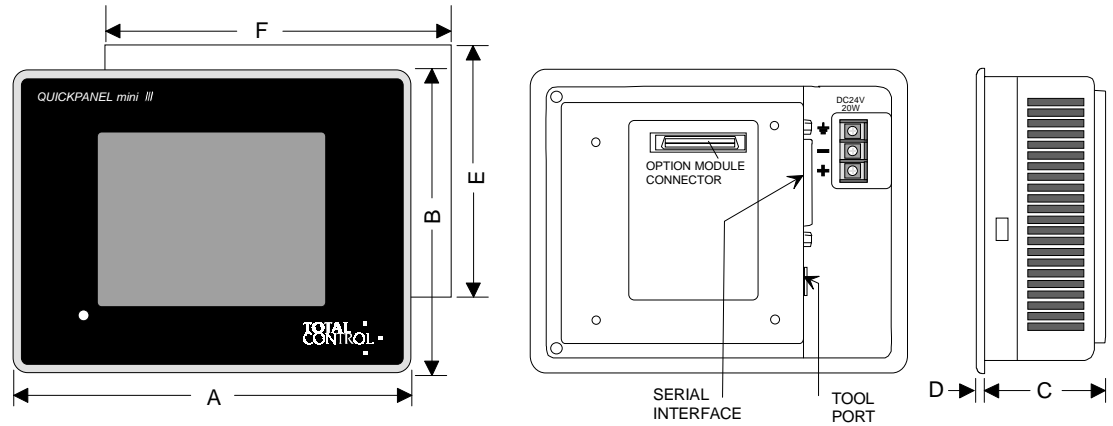

Model	Dim A	Dim B	Dim C	Dim D	Dim E	Dim F
QPM-2xxxx-L2P	8.267" (210mm)	6.299" (160mm)	2.28" (58mm)	.197" (5mm)	5.59" (142mm)	7.56" (192mm)

Communications

Serial Interface Port

The serial interface port connects the QUICKPANEL to your PLC. Refer to the cable section to determine the correct cable to use with your PLC. Factory cables are cut to approximately 12', which is suitable for most applications. Some cables are available in longer lengths on special order from Total Control Products, Inc. or you can fabricate your own. Use the cable diagrams found in the cable section for correct wiring. Remember that RS232 cables are reliable up to approximately 50'. The serial interface pin assignments are shown in the following drawing.

*NOTE: Some cables, such as the HMI-CAB-C84, are designed for use on proprietary networks. These cable assemblies contain active network interface circuits. Because these cables are licensed from other manufacturers, there are no cable diagrams or circuit drawings.

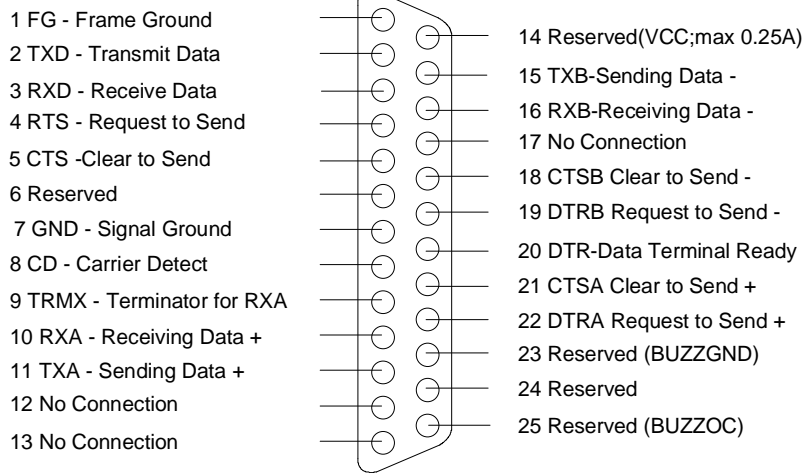

Serial Interface Port Specs

Transmission: Asynchronous RS232C/RS422

Data Length: 7 or 8 data bits

Stop Bit: 1 or 2

Parity: None, Odd or Even

Data Transmission Speed: 300 to 38.4Kbps. (Depends on the Protocol)

Parallel Printer Port

Conforms to Centronix standards, HP LaserJet PCL4 compatible, NEC PR201 series, EPSON ESC/P 24-Pin (High Quality) or equivalent can be connected. See the HMI-CAB-C99 cable diagram.

Download Port

This port has several names, depending on how it is used. To simplify the reference, the port is generally called the download port. This port is used to download application files from a computer to the QUICKPANEL or print alarm messages to a printer. For download applications, use the HMI-CAB-C49 cable. For serial printer functions, use the HMI-CAB-C150 cable.

The download files are created by QUICKDESIGNER software running in Windows on your computer. The download port uses TTL signal levels and requires conversion to RS232, RS485 or other communication standard. The HMI-CAB-C49 cable is used to convert the TTL signals to RS232. The download port connector is an 8-pin mini-DIN style. The port pin configuration and pin assignments are shown in the following drawing.

Data Transmission Speed: 2400 to 38.4Kbps. (QPI-3 to 115.2Kbps)

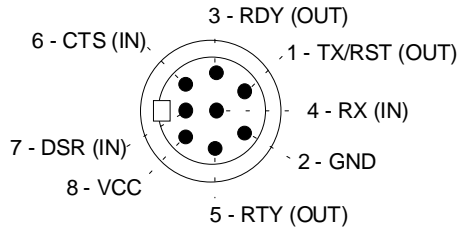

Download Cable, HMI-CAB-C49

The primary use of the HMI-CAB-C49 cable is to download QUICKDESIGNER files from your computer to a QUICKPANEL display. This cable contains a TTL to RS232 converter and should not be modified.

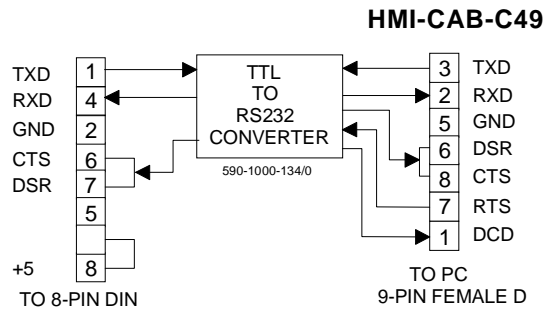
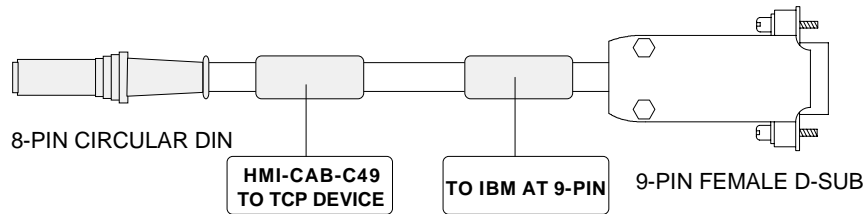

PROPRIETARY INFORMATION

THIS INFORMATION IS PROVIDED AS A CONVENIENCE TO OUR CUSTOMERS. YOU ARE NOT AUTHORIZED TO CONSTRUCT THIS CABLE. UNAUTHORIZED CABLES ARE NOT SUPPORTED BY TOTAL CONTROL.

Printer Cable, HMI-CAB-C105

The primary use of the HMI-CAB-C105 cable is to print alarm messages from your QUICKPANEL display. This cable contains a TTL to RS232 converter and should not be modified.

Do NOT attempt to connect a serial printer directly to the download port because the download port signals are TTL. Most serial printers require RS232. Use the HMI-CAB-105 cable to connect a serial printer to the download port.

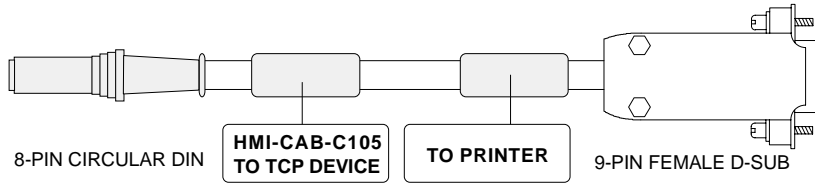

HMI-CAB-C105

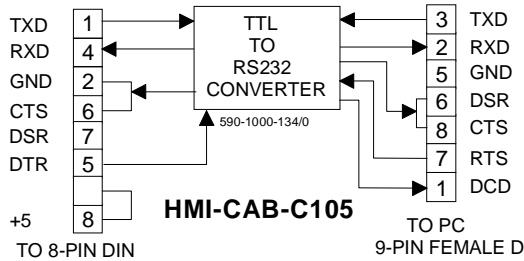

PROPRIETARY INFORMATION

THIS INFORMATION IS PROVIDED AS A CONVENIENCE TO OUR CUSTOMERS. YOU ARE NOT AUTHORIZED TO CONSTRUCT THIS CABLE. UNAUTHORIZED CABLES ARE NOT SUPPORTED BY TOTAL CONTROL.

Cables

A typical cable assembly is shown in the following drawing. A label is placed on each end of the cable to indicate which device should be connected to that end. One of the labels will also indicate the cable part number so you can quickly verify you are using the right cable for your application.

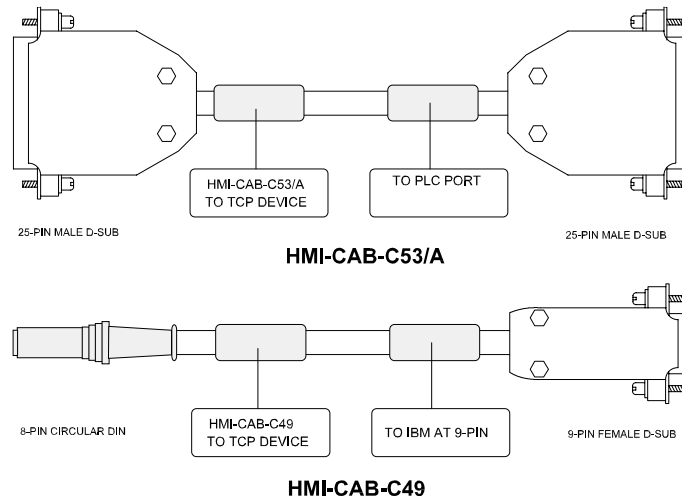

NOTE

Not all cables are shown in the cable drawings section. Cables that contain circuit boards are not shown because they cannot be fabricated in the field. The cable drawings are provided for those users that wish to fabricate their own cable assemblies

Cable Drawings

This section includes a drawing of the cable and the wiring diagram. Not all cables are included in this section. Some cable assemblies have a circuit board in the connector housing to provide for specific voltage levels and protocols. Those cable assemblies that have a circuit board are NOT included.

The following cable assemblies contain a circuit board and are NOT included in the cable drawings:

HMI-CAB-C49

HMI-CAB-C76

HMI-CAB-C104 (SIEMENS 3964R)

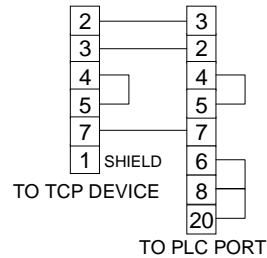
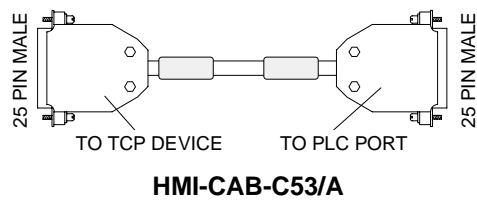
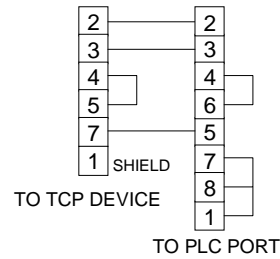
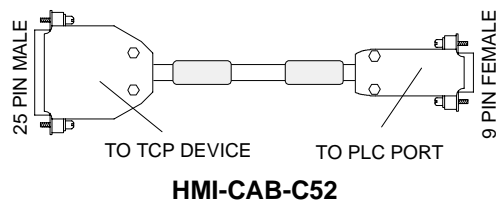
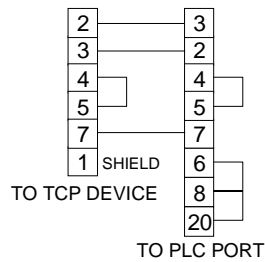
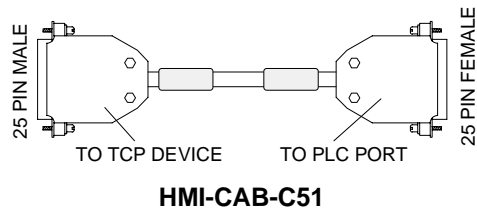

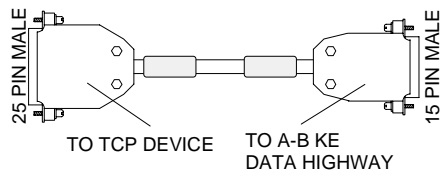

HMI-CAB-C55

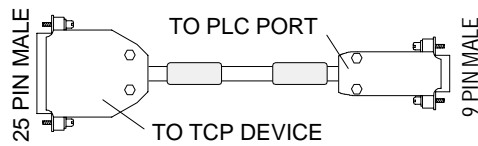
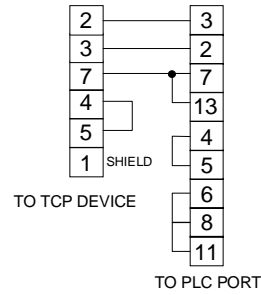

HMI-CAB-C58

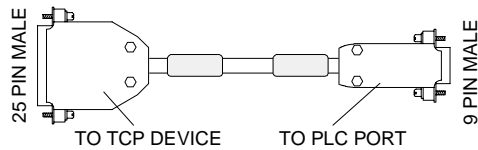
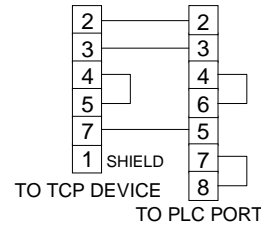

HMI-CAB-C67

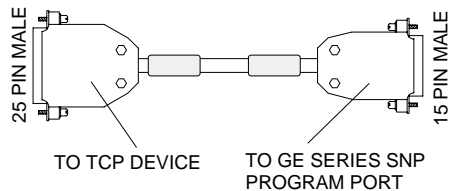
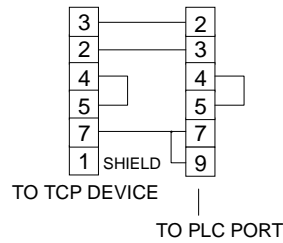

HMI-CAB-C82

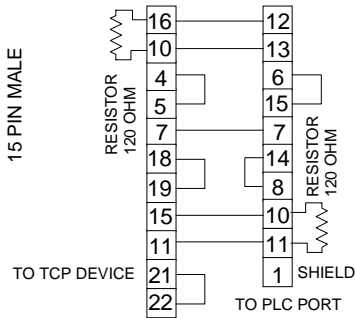

NOTE: The HMI-CAB-C83/A Cable drawing is proprietary information and is provided for reference ONLY. You are not authorized to construct this cable.

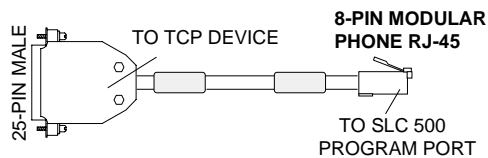

HMI-CAB-C83/A

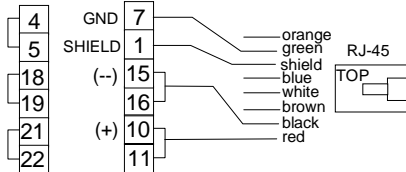

NOTE: The HMI-CAB-C84/A Cable drawing is proprietary information and is provided for reference ONLY. The RS232 to RS422 circuit board is contained in the 25-pin D-shell. The circuit also provides network control. The cable is licensed from Allen-Bradley and cannot be modified.

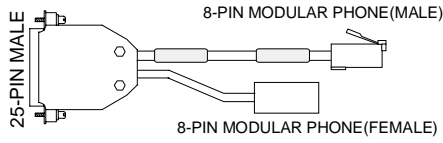

HMI-CAB-C84/A

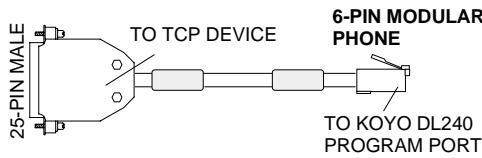
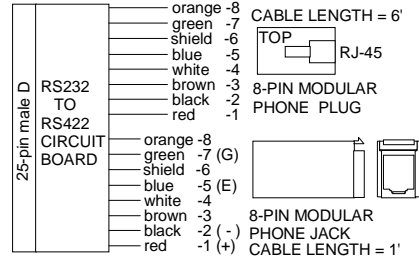

HMI-CAB-C86/B

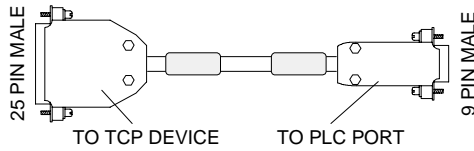
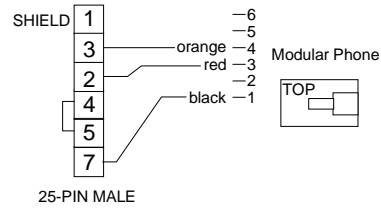

HMI-CAB-C88

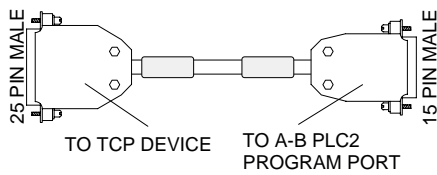
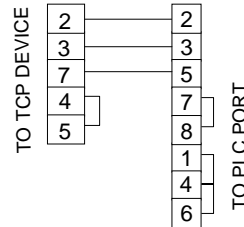

HMI-CAB-C90

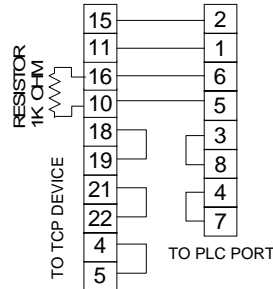

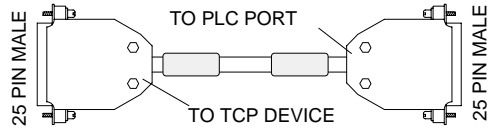

HMI-CAB-C91/B

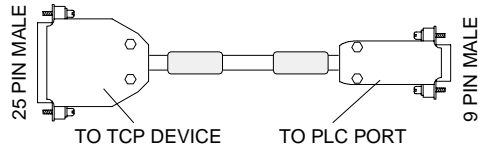
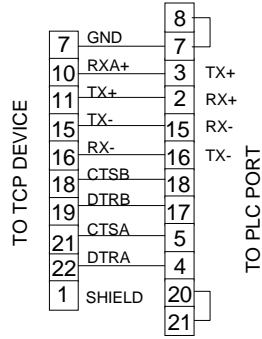

HMI-CAB-C92

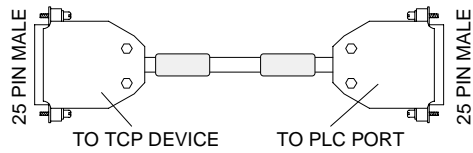
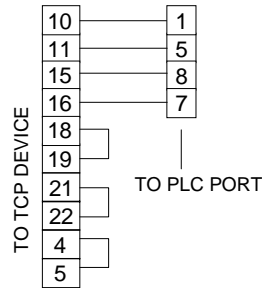

HMI-CAB-C93

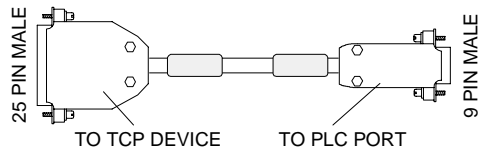
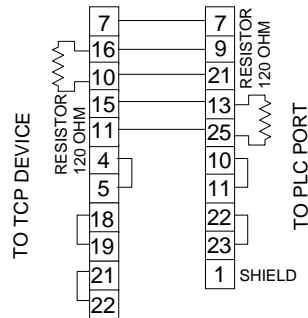

HMI-CAB-C94

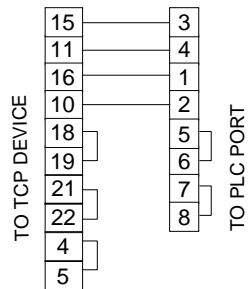

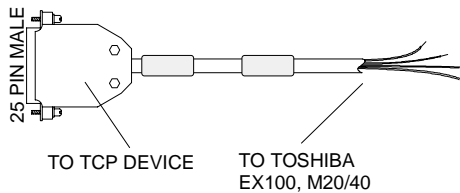

HMI-CAB-C96

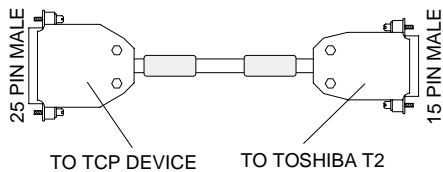
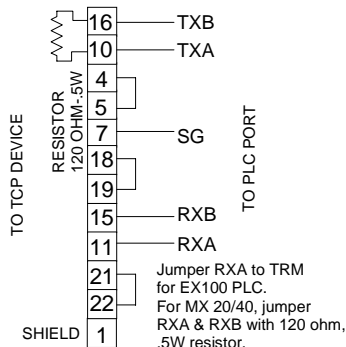

HMI-CAB-C97

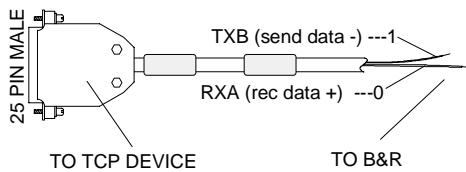
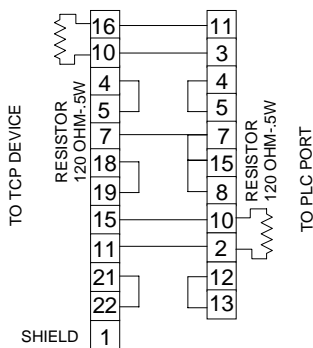

HMI-CAB-C98

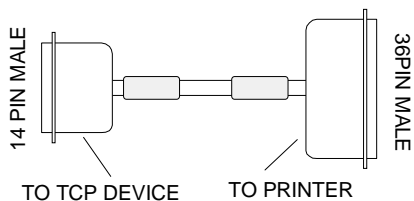
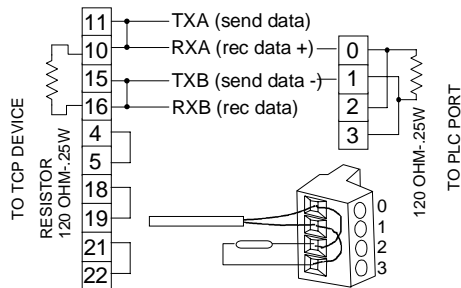

HMI-CAB-C99

TO PRINTER PORT

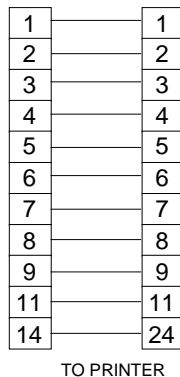

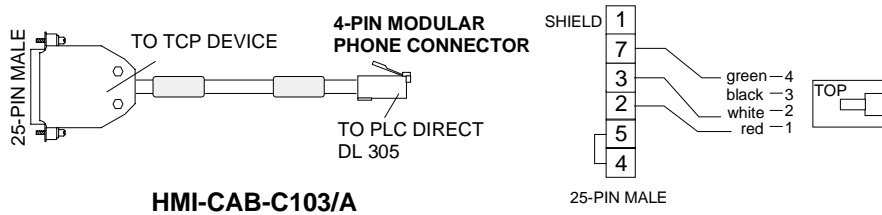
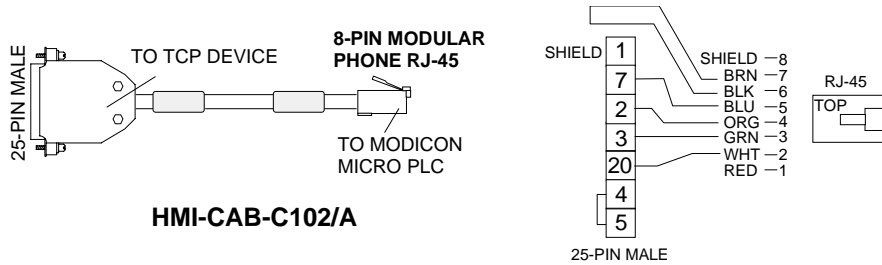
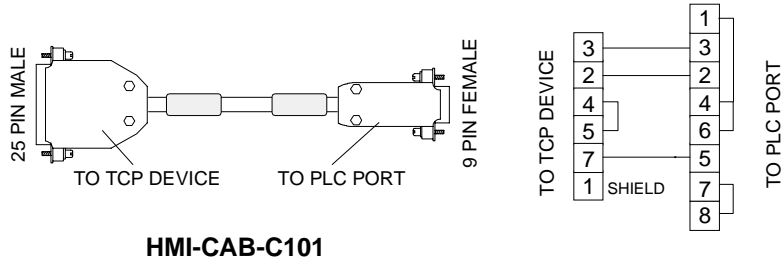
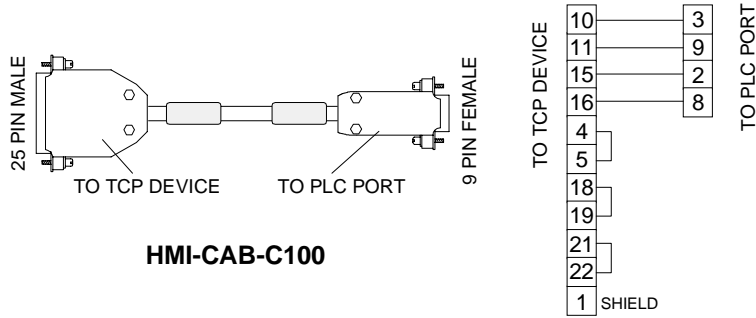

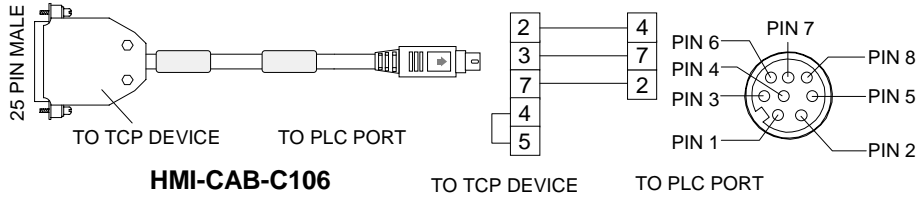

NOTE: The 8-pin DIN connector requires precise pin alignment before pressing the connector into the housing on the MicroLogix 1000. This is a TIGHT fit and requires some force.

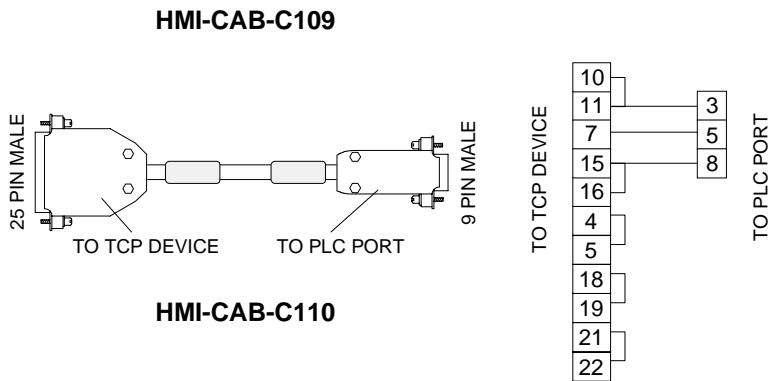
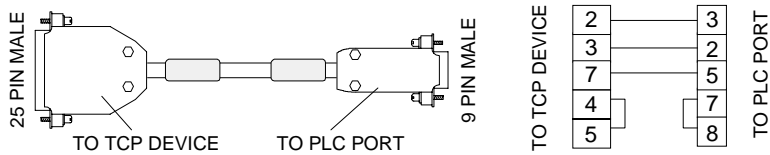
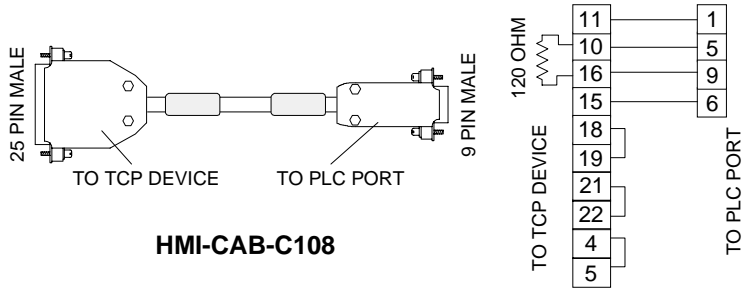
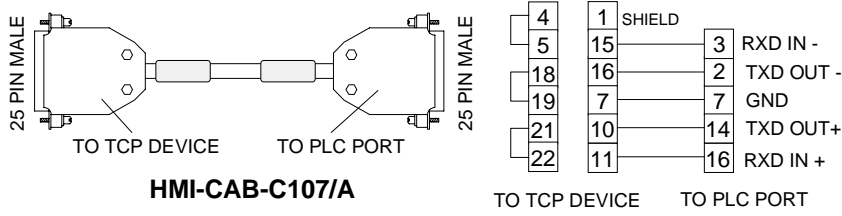

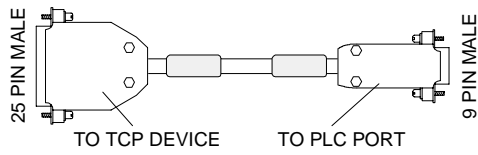

HMI-CAB-C111

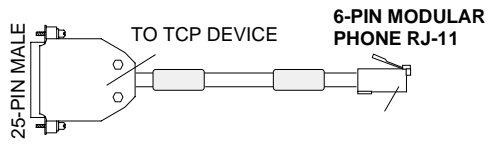
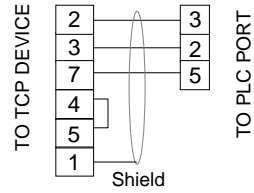

HMI-CAB-C112

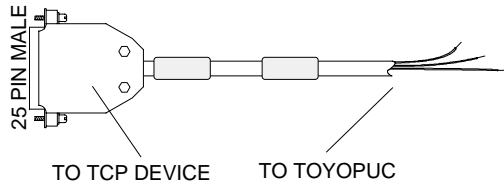
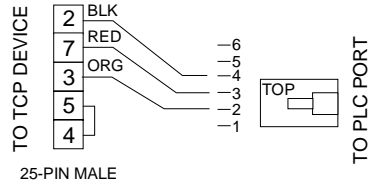

HMI-CAB-C113

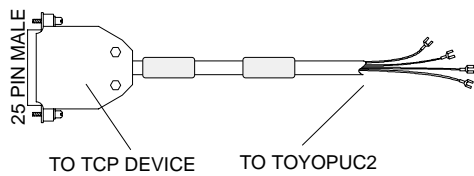
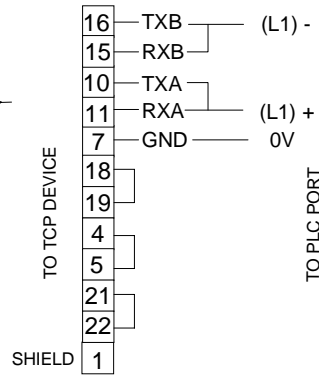

HMI-CAB-C114

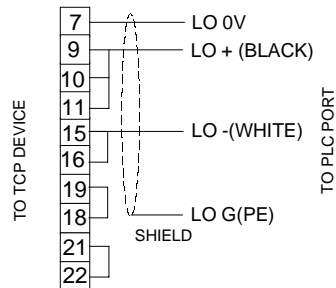

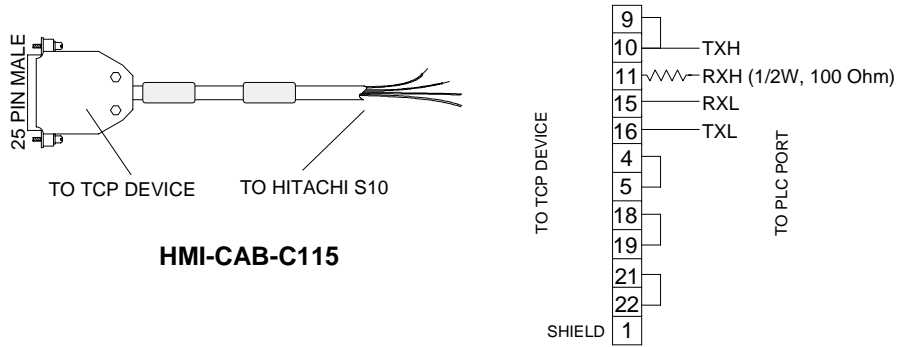

HMI-CAB-C115

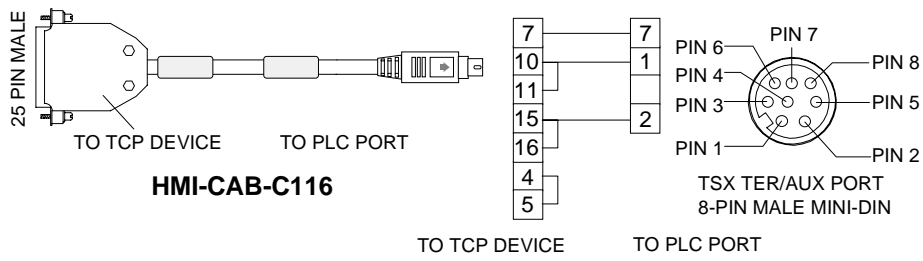

HMI-CAB-C116

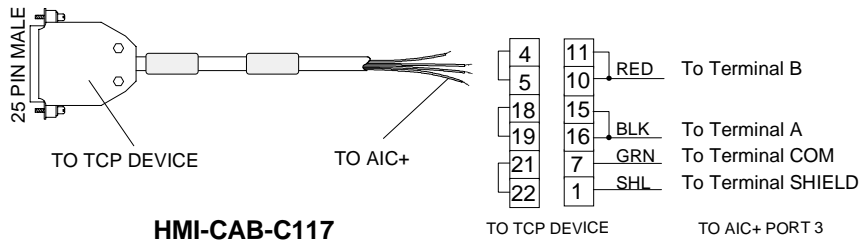

HMI-CAB-C117

Cable Chart

PLC Manufacturer.	PLC Type	Description	Catalog Number	
Allen-Bradley		DH-485 Program port, one SLC to one QuickPanel, no simultaneous program port.	HMI-CAB-C83	
	SLC500, SLC5/01, SLC5/02, SLC5/03	DH-485 program port, one SLC to one QuickPanel, with simultaneous program port, 6 foot max.	HMI-CAB-C84	
		DH-485 link via 1447 AIC module, multiple QuickPanels to multiple SLC's, 6 foot max.	HMI-CAB-C84	
	SLC5/03, SLC5/04	Channel 0, 9 pin RS-232	HMI-CAB-C52	
	PLC5	Channel 0, 25 pin RS-232	HMI-CAB-C53	
		DF1 RS-422	HMI-CAB-C107	
		KF2 module, 25 pin RS-232	HMI-CAB-C51	
		KE module	HMI-CAB-C55	
	PLC2	Program Port, 15 pin RS-422	HMI-CAB-C90	
	MicroLogix	DF1 Protocol	HIM-CAB-C106	
	AIC+ Advanced Interface Cnvtr	DH485 Port 3	HMI-CAB-C117	
Aromat	Aromat FP1 (MEWNET)	9 pin Male RS-232	HMI-CAB-C111	
B & R	Mininet	2-plated wires RS-422	HMI-CAB-C98	
General Electric	90/30, 90/70	Program Port, 15 pin RS422	HMI-CAB-C82	
	SNP protocol	CMM Module	25 pin RS-232	HMI-CAB-C53
			25 pin RS-422	HMI-CAB-C93
Hitachi	Hitachi S Serial Protocol	4 plated wires RS-422	HMI-CAB-C115	
IDEC	Micro-1, FA via link adapter	25 pin RS-232	HMI-CAB-C53	
	Micro-3	9 pin male	HMI-CAB-C109	
Keyence	Keyence KV-L2, KV-10R	RJ11 RS-232 Program Port	HMI-CAB-112	
	Keyence KV-L2	25 pin RS-232, Port 1	HMI-CAB-C53	
Koyo	see PLC Direct	see PLC Direct		
Micrologix		8 pin DIN	HMI-CAB-C106	
Mitsubishi	Series A1S	9 pin RS-232, for A1SJ71C24-R2	HMI-CAB-C88	
	Series A	25 pin RS-232	HMI-CAB-C53	
	FX	25 pin RS-422	HMI-CAB-C91	
	FX0	25 pin RS-422 via an adapter	HMI-CAB-C91	
Modicon	984 A, B, X	25 pin RS-232	HMI-CAB-C53	
	984 Slot and compact	9 pin RS-232	HMI-CAB-C58	
	984 micro	RJ45 headset connector RS-232	HMI-CAB-C102	
Omron	C200H	25 pin RS-232	HMI-CAB-C53	
	C200H	9 pin RS-422	HMI-CAB-C108	
	C20H, CQM1,	9 pin RS-232	HMI-CAB-C67	

PLC Direct	DL430, 440 Port 2, D4-DCM	25 pin RS-232	HMI-CAB-C53
	DL330, 330P with use of D3-232-DCU, DL350 Port 2, DL450 Port A	25 pin RS-232	HMI-CAB-C53
	DL340	4-pin Modular Phone RS-232	HMI-CAB-C103
	DL250 Port 1	6-pin Modular Phone RS-232	HMI-CAB-C86
	DL350 Port 1, DL240 Port 2	6-pin Modular Phone RS-232	HMI-CAB-C86
Reliance	Automate program port, R-net gateway	25 pin RS-232	HMI-CAB-C53
Siemens	S5 family program port	15 pin current loop	HMI-CAB-C76
	3964R 928B TTY Sub Module	25 pin Male Current Loop	HMI-CAB-C104
	3964R 928B RS232 Sub Module	25 pin RS-232	HMI-CAB-C53
	S7-200	9 pin male	HMI-CAB-C110
Simatic TI	305 with use a RS-232 DCU	25 pin RS-232	HMI-CAB-C53
	405	25 pin RS-232	HMI-CAB-C53
	500 series, 25 pin prog. port	25 pin RS-232	HMI-CAB-C53
	500 series, 9 pin prog. port	9 pin female RS-232	HMI-CAB-C101
	500 series, 9 pin RS-422	9 pin male RS-422	HMI-CAB-C92
	TI545-1102, prog. port	9 pin female RS-422	HMI-CAB-C100
Square D	Symax model 100 and greater	9 pin male RS-422	HMI-CAB-C94
	Symax model 50 via link adptr	25 pin RS-232	HMI-CAB-C53
Toshiba	T2	15 pin male RS422	HMI-CAB-C97
	MX, EX	4 plated wires RS-422	HMI-CAB-C96
Toyopuc	Toyopuc PC1	3 plated wires RS-422 Half Duplex	HMI-CAB-C113
	Toyopuc PC2F	4 spade lug RS-422 Half Duplex	HMI-CAB-C114
Uni-Telway	TSX37 Series	8 pin male mini-DIN	HMI-CAB-116

Hand Held QuickPanel

The Hand Held QuickPanel combines a 6" Passive STN LCD Color or Monochrome LCD flat panel display with a resistive touch panel, 11 programmable function keys, and a Push Lock switch into a compact package. The unit is housed in an ultra thin body with a wrist strap for a firm grip and hold. An operator keypad on the front (OP) or a switch under the hand grip will enable the touch screen and keypads. The unit is compatible with Quick Designer Advanced Software, providing support for over 25 PLC drivers.

The Hand Held QuickPanel connects to a Junction Box through the HMI-CAB-A02 Interface Cable. The Junction Box, HMI-JBX-201, has terminal blocks for 24VDC, Push Lock switch contacts, a buzzer, and other control signals. Standard PLC cables connect to the Junction Box 25 pin female connector for easy connection to your PLC.

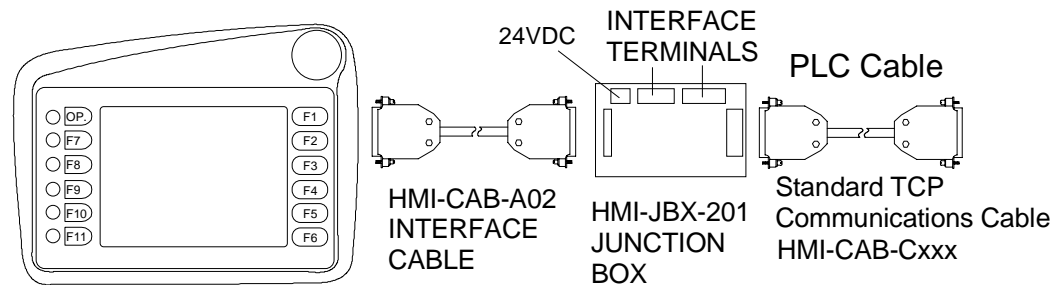

Installation

Before starting the installation process, make sure you have the following parts.

QPH-2D100-L2P 6" Monochrome LCD Hand Held QuickPanel

or

QPH-2D100-S2P 6" Color STN LCD Hand Held QuickPanel

HMI-CAB-A02 Cable

HMI-JBX-201 Junction Box

510-1000-004 24VDC 1.3A Power Supply (or equivalent)

Interface Cable

The Interface Cable connects the Hand Held QuickPanel to the Junction Box. All of the interface signals, power, and control signals are contained in the interface cable.

Remove the access cover from the back of the display.

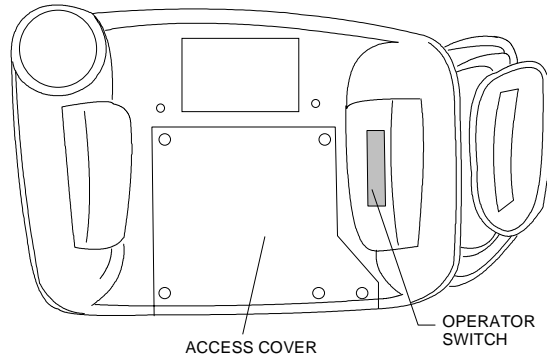

Locate the connector marked CN1. The connector marked CN2 is the download port.

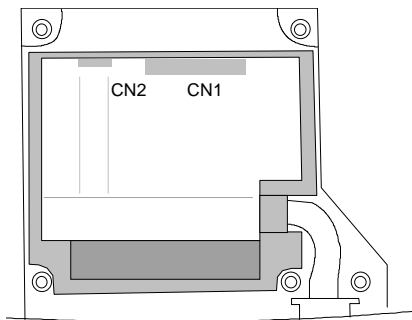

Connect one end of the HMI-CAB-A02 cable to the CN1 connector. Route the cable under the gasket and along the molded cable channel. Replace the access cover. The other end of the cable will be connected to the 36 pin connector on the HMI-JBX-201 Junction Box.

*You can leave the cover off temporarily if you intend to use the CN2 download port for loading an application. Keep the access cover in place to provide cable strain relief.

Junction Box

The junction box provides a signal connection system between the Hand Held QuickPanel and the PLC. It provides mating connectors for the cable from the Hand Held QuickPanel and a 25 pin female connector for all standard Total Control PLC cables. The Junction Box also has terminal connections for control signals and power input for the Hand Held QuickPanel. Connect the HMI-CAB-A02 Cable to the 36 pin connector on the HMI-JBX-201 Junction Box.

The Junction Box is mounted to a panel using 0.5" standoff fasteners. The Junction Box dimensions and terminal locations are shown in the following drawing.

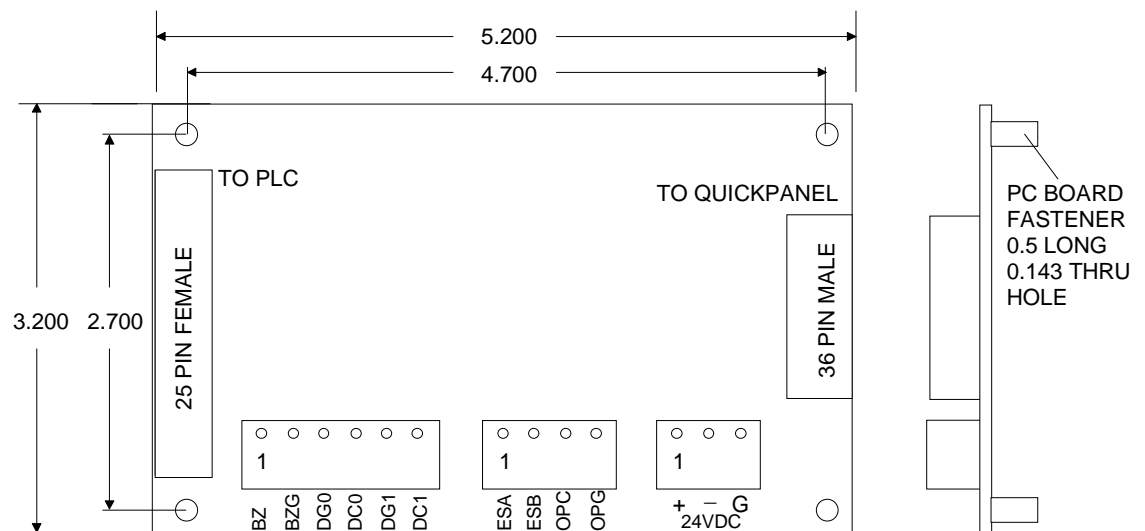

24 VDC Power

Use the 510-1000-004 24VDC 1.3A Power Supply or equivalent. Connect the leads to the screw terminals on the Junction Box. Power is supplied to the Hand Held QuickPanel through the HMI-CAB-A02 Interface Cable.

PLC Cable

Connect a standard Total Control PLC interface cable to the 25 pin female connector on the Junction Box. These cables can be identified by their HMI-CAB-xxxx part number printed on the cable. The cable ends are marked to indicate which end goes to the PLC and which goes to the QuickPanel.

Beeper Connection

The screen beeper can be tied to an external beeper or other sound device. Remember that the beeper is enabled or disabled by the setting in the Touch Screen dialog box. When the beeper is enabled, touching the screen will activate the external signal. This is an open collector output. See the sample beeper connection in the next drawing.

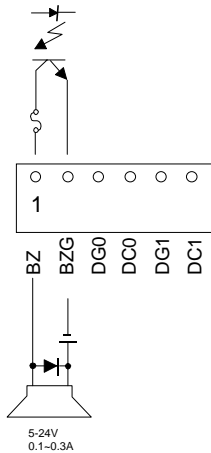

Operator Button Connection

Pressing the OP button on the front of the display or pressing the operator switch under the hand grip will activate the Operator signal. This is an open collector output. See the sample operator button connection in the next drawing.

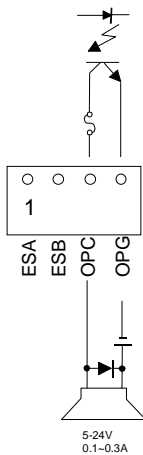

Emergency Button

The emergency button is a normally closed contact switch located on the front of the unit. Pressing the button will lock it in the open contact position. Rotate the switch knob to reset it to the normal position. The contact terminals and sample wiring are shown below.

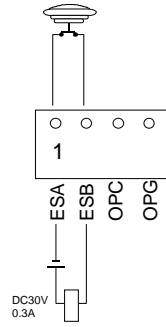

Custom Cables

The following drawing shows the cable connector and pin assignments for the Hand Held Quick Panel. Use this cable drawing when you need to create custom cable sets.

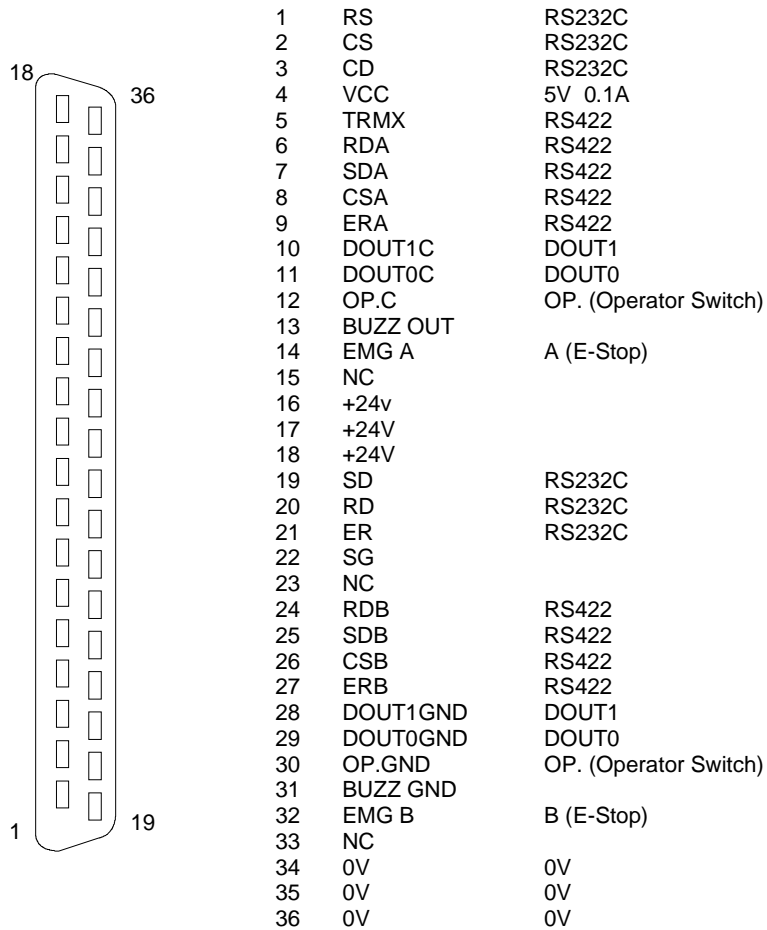

Connector: HONDA PCR-E36FS 36 PIN

Shell:HONDA PCS-E36LA

Cable: MHOTRONICS FURUKAWA OAW(C)-SB-18P

Project Setup

Setup begins with selecting the QuickPanel HandHeld in the Project Setup menu under Display Device. The new selections will be shown as:

QUICKPANEL 6" HandHeld Color
QUICKPANEL 6" HandHeld Monochrome

Selecting a Hand Held unit will cause some changes in various dialog boxes. Below is the Touch Screen Configuration dialog box. Note the *Keyboard attached* selection is permanently checked and grayed out.



Note the addition of a new checkbox labeled *Operation Switch Off*. The Hand Held is equipped with an OP (operation) keypad on the front of the unit, and a finger switch (sometimes known as dead man switch) located on the back under the left hand grip. Pressing either switch will enable the touch screen. Checking the *Operation Switch Off* will disable the switch function and the touch screen will always be enabled.

Function Keypads

A 6" QuickPanel can be used with the optional keypad assembly to enhance the operation of the QuickPanel. You must check the *Keyboard attached* checkbox in the Touch Screen Configuration dialog box to enable the Advanced button in several operator dialog boxes. The Advanced button allows simulating operators and assigning keypads to screen operators. The Hand Held unit also has keypads (called Function keys) around the display, but when you select it as the display device, the *Keyboard attached* checkbox is permanently checked.

The Function keys are used in place of the touch screen or along with the touch screen. For example, instead of touching the QuickPanel screen to activate a Push Button, you can press a Function key. You can also assign a Function key to simulate a push button, selector switch, goto panel button, numeric data entry, print screen button or word button. Simulating operators saves screen space.

The following panel operators (ones with a bezel) can be assigned to Function keys:

Push Button
Illuminated Push Button
Numeric Data Entry (with external numeric keypad)
Selector Switch
Word Button
Goto Panel Button
Print Screen
Alarms

The addition of Function keys to the standard touch screen allows several options. For example, a Push Button can:

- work normally without using a Function key.
- be assigned to a Function key.
- work normally and with a Function key.
- be simulated by a Function key but not appear on the touch screen.

Keypad Layout

The diagram below shows the physical layout of the keypads. The keypads are marked F1 through F11. The keypad marked OP is the Operator keypad, which works the same as the switch under the hand grip.

Error! Objects cannot be created from editing field codes.

Assigning Keypads

You can assign a keypad to a button by clicking the Advanced button in the settings dialog. Clicking the Advanced button displays the Advanced Settings dialog box.

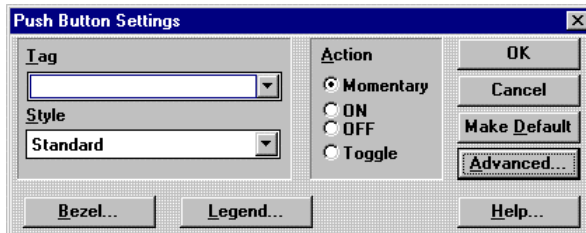

In the following example, a button was assigned to Function key F1. Once a button is given a Key Assignment, the Touch disabled checkbox becomes active. A button object can be connected to the touch screen and a Function key simultaneously. If you click the Touch disabled checkbox, the touch screen will be disabled for the button and the button will only work with the assigned Function key. A list of all Function key assignments can be displayed by going to the Tools menu and selecting Keypad Assignments.



The Illuminated Push Button, Selector Switch, Goto Panel Button and the Word Button work the same way.

Function Keys and Alarms

When an alarm is triggered, the alarm message appears on the panel in an alarm window. The operator touches the window area to activate the alarm management page. If you assign a Function key to an Alarm window, the alarm management page will have an additional row showing Function key assignments.

The alarm management page function keys (Up, Down, Ack, etc.) will now have permanent Function key assignments. Up is F1, Del is F3 and so on. The touch screen and the Function

keys work in parallel. If the touch screen is disabled, only the Function keys will operate the alarm page functions.

ACTIVE ALARMS							
09/19 13:28 ALARM TEXT MESSAGE #1							
09/19 13:40 ALARM TEXT MESSAGE #2							
Up	Down	Ack	Del	Ack All	Del All	MODE	DONE
F0	F1	F2	F3	F4	F5	F6	F7

Simulating Panel Objects with Function Keys

You can assign a Function key to simulate a panel object, even though there is no panel object visible on the screen. You can assign one of the Function keys to simulate the following panel operators:

- Push Button*
- Goto Panel Button*
- Print Screen Button*
- Word Button*
- Selector Switch*
- Numeric Data Entry*

To create a simulated panel object, go to the TOOLS menu and select Keypad Assignments.

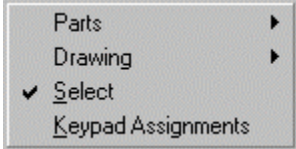

The keypad key assignment dialog box appears.

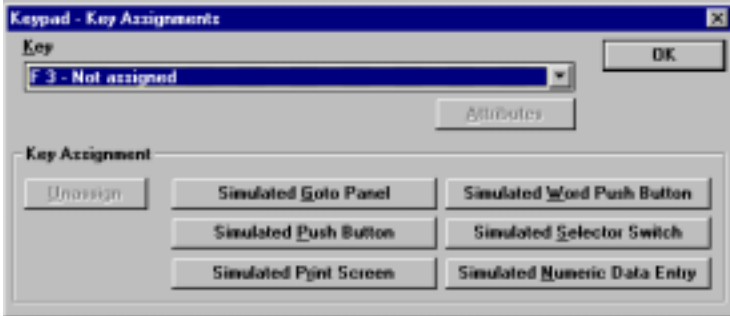

The first operation is to select which Function key will be assigned to the simulated panel operator. Click the down arrow in the Key list box then click an unassigned Function key.

Next, select one of the operators to simulate by clicking a button in the Key Assignment area. When you click one of the simulate keys, the rest of the buttons will be grayed out. In the following example, Function key F3 has been assigned to a Simulated Push Button.



Click the Attributes button to open the settings dialog for the selected item. In this example, clicking the Attributes button will open the Push Button settings dialog. Enter the tag information and click the OK button.

Now when you press the F3 Function key, a Push Button operation is simulated.

Viewing Keypad Assignments

To view the keypad assignments, go to the View menu and click the Object Key Display. The keypad tag display is similar to the object tag display.

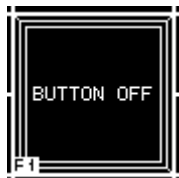

The keypad tag is displayed in the bottom left corner of the operator and provides a quick visual check to see which panel operators have Function keys assigned.

Video QuickPanel

The Video display QuickPanel is a special member of the QuickPanel family. Real time video display can be added to control panels for another view into your control process.

The Video QuickPanel is a standard 10.5" TFT Active Color display with a resistive touch screen.

The video display can be selected to cover all panel objects, to display in objects of selected color, or have selected colors appear through the video.

Installation

The installation of the 10.5" display is the same as other 10.5" Color displays, except for the addition of the video input signals. In the Setup dialog box, select the QuickPanel 10.5" Color Video. This selection automatically adds the video icon to the tools menu.

Video Inputs

The Video QuickPanel has the standard serial, printer and tool ports. It also has three NTSC BNC video inputs. The following drawing shows the location of the ports and input connectors.

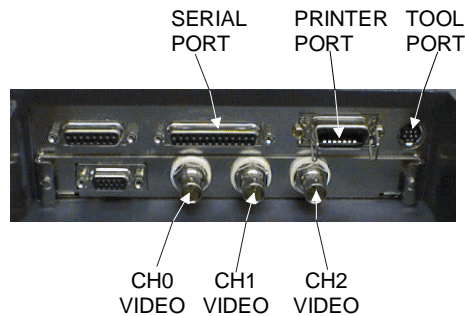

The video source must be NTSC. The video output from a camcorder or VCR is usually an RCA phono plug type connector. An easy way to connect these video sources is by adding an RF adapter to the Video QuickPanel. A typical phono plug to BNC connector can be found at a local Radio Shack under the part number 278-254. Also, many computer stores sell BNC cables for use in networks. These cables can be used to connect video signals that require BNC style connectors.

Video Display

To add a video operator to a panel, select the video icon  from the floating tools menu. Move the cursor to the panel area where the video will appear and click the mouse. The video will be displayed in a 300W x 200H area, along with operator buttons and legend data. A sample video display with two buttons is shown below.

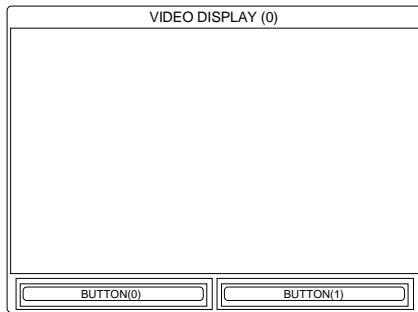

The following Video Display Settings dialog is displayed.

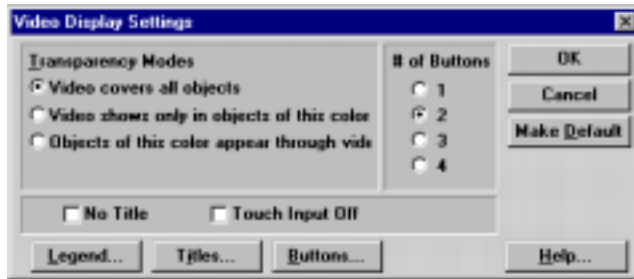

Transparency Modes

Three modes are available for displaying the video. The options allow for a wide range of display options and panel design functionality.

In the *Video covers all objects mode*, the video appears over all objects. You can hide a button behind the display.

When you select *Objects of this color appear through video* or *Video shows only in objects of this color* mode, the Video Display Settings dialog changes to show a color selection option.

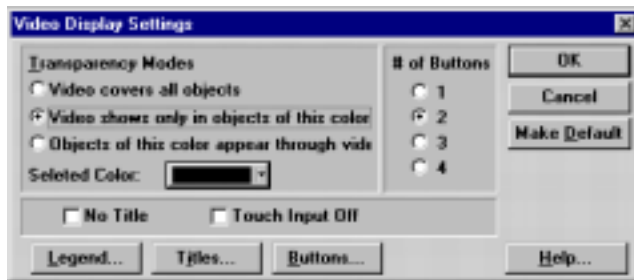

In the *Video shows only in objects of this color* mode, the video will be seen only when an object of the selected color is in front of the video display (the object must be placed in the foreground). For example, if you create a push button with a red legend plate and the selected color is red, then the video will only be shown on the legend plate. The video will not appear on parts of the push button that have a different color.

In the *Objects of this color appear through video* mode, any object of the selected color will appear on the video display. For example, if you create a push button with a green bezel, and the selected color is green, then the bezel part of the button will be seen on the video display.

NOTE: In order for objects to work with transparency, they must be placed in the foreground, or in front of the video display.

Number of Buttons

Select the number of buttons that will appear in the video display legend. The buttons are located below the video display and will size as the legend plate is sized. The video display will always remain 300x200 pixels. The buttons select different video sources. Each button has its own legend plate with title.

No Title

Click on the *No Title* checkbox to remove the title from the legend plate.

Touch Input Off

Click on *Touch Input Off* to turn off the touch screen in front of the video display. This does not effect objects around the video display window.

Legend Plate Settings

You can change the background and outline colors of the video display legend. Click the *Legend* button to display the following dialog box.



The background and outline sections are shown in the next drawing.

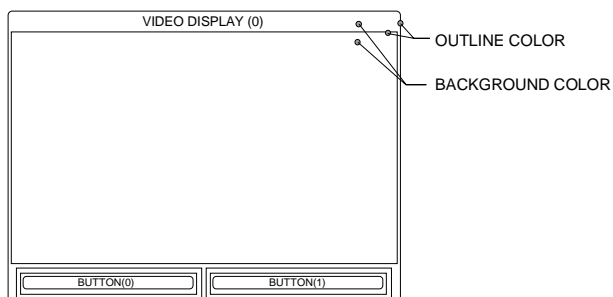

Titles

Click the *Titles* button to display the Title Settings dialog box. The number of buttons selected will determine the number of legend plates. In the next drawing, two buttons have been selected. Pressing button 0 will display legend plate 0, and button 1 will display legend plate 1. You can customize the title for each legend plate.

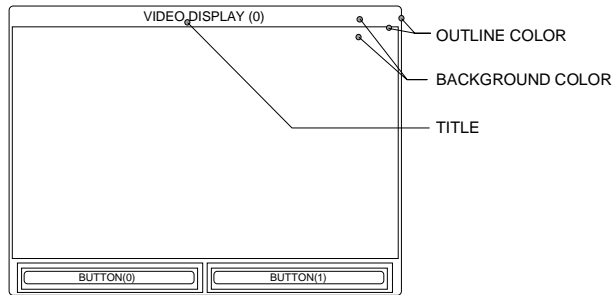

Buttons

Click *Buttons* to display the Control Button Settings dialog. This dialog is used to setup the buttons that appear below the video display. The buttons select which video source channel is being displayed. You can customize the buttons for your application.



The *Buttons No.* information box displays the assigned button number. The *Channel No.* list box selects the video source for the assigned button. Each button can select from CH0, CH1, or CH2. Although the spin controls allow selection of CH3, it is not used in this product.

Color Adjustments

Adjust the contrast, brightness, and color balance by going into setup mode. Setup mode can be entered in the power up condition or during the RUN condition.

Power up the unit and press and hold the upper corners of the display. The unit will enter the setup mode with the MAIN MENU displayed. Press button 1, INITIALIZE, then button 1, SYSTEM ENVIRONMENT SETUP. Select button 6, VIDEO DISPLAY ADJUSTMENT. Select the INPUT CHANNEL at the bottom of the screen by pressing one of the channel numbers. The video will appear on the left side of the screen. Set the brightness, contrast, and color or simply press the default button. When done, press the SET button to exit the adjustment setup. Press MAIN MENU, then press RUN. The unit will now go into normal RUN mode.

While the unit is in RUN mode, press the bottom corners and the upper right corner at the same time. This is often called the three finger reset. Press the OFFLINE button on the bottom of the screen. The unit will enter the setup mode with the MAIN MENU displayed. Press button 1, INITIALIZE, then button 1, SYSTEM ENVIRONMENT SETUP. Select button 6, VIDEO DISPLAY ADJUSTMENT. Select the INPUT CHANNEL at the bottom of the screen by pressing one of the channel numbers. The video will appear on the left side of the screen. Set the brightness, contrast, and color or simply press the default button. When done, press the SET button to exit the adjustment setup. Press MAIN MENU, then press RUN. The unit will now go into normal RUN mode.

DO NOT CHANGE ANY OTHER SETTINGS IN THE SETUP MODE.

QuickPanel Mini

The QuickPanel Mini is a 6" LCD monochrome touchscreen product. The QuickPanel Mini provides limited panel functionality with full PLC communications capabilities.

To select the QuickPanel Mini as the target display device, choose **Setup** and select **QuickPanel Mini 6" Monochrome** as the Model.

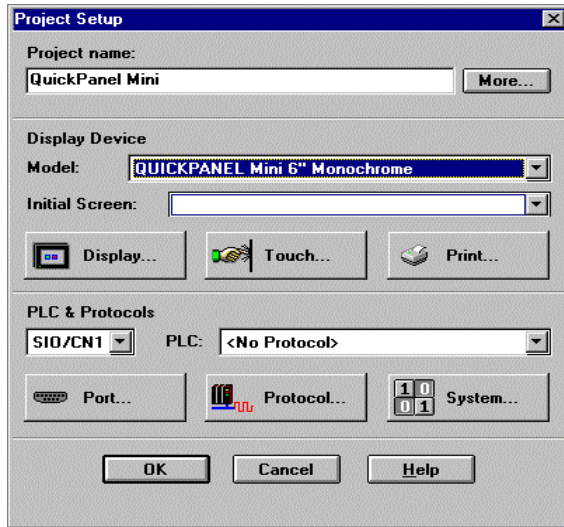

Panel Operators

The QuickPanel Mini has a limited set of tools in the Toolbox. The operators that are available for this product are the Pushbutton, Illuminated Pushbutton, Pilot Light, Local Message Display, Selector Switch, Bitmap, Legend Plate, Text, Numeric Entry, Numeric Display, and GoTo Panel.



Application Memory

The QuickPanel Mini provides a total of 5 panels to be used for an application. Objects can be placed anywhere on a panel (including overlaying objects). Each panel does have a limit to the number of objects that can be placed on each panel. Only **128** object “functions” can be placed on a panel at one time. To check the number of functions currently on the panel, click

the check (doctor bag)  icon. This feature is not supported when panel objects are grouped.

The following dialog box appears, indicating the number of resource objects on the panel.

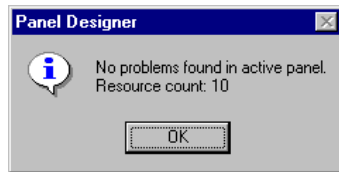

If the object function limitation is exceeded, a message will appear during the compile stage of the download. The compiler will stop on the panel that has exceeded the maximum panel count. The download will be aborted until the panel in error is corrected.

The object function count for each object is listed below:

Pushbutton—3
Illuminated PB—4
Pilot Pilot—1
Numeric Display—1
Numeric Entry—3
Legend plate—0
Static Text—0
Message Display—2
GoTo button—3
Bitmap—0
Selector switch--4

NEMA 4X Bezels

Bezel Assembly Overview

The following diagram shows the basic elements of a bezel assembly. The basic assembly is the same for all displays. The display is clamped to the stainless steel bezel by means of a clamp bracket. A full size gasket seals the display to the bezel. The bezel is secured to the panel by 10-32 x .50 threaded studs and nuts. The gasket also seals the bezel assembly to the panel.

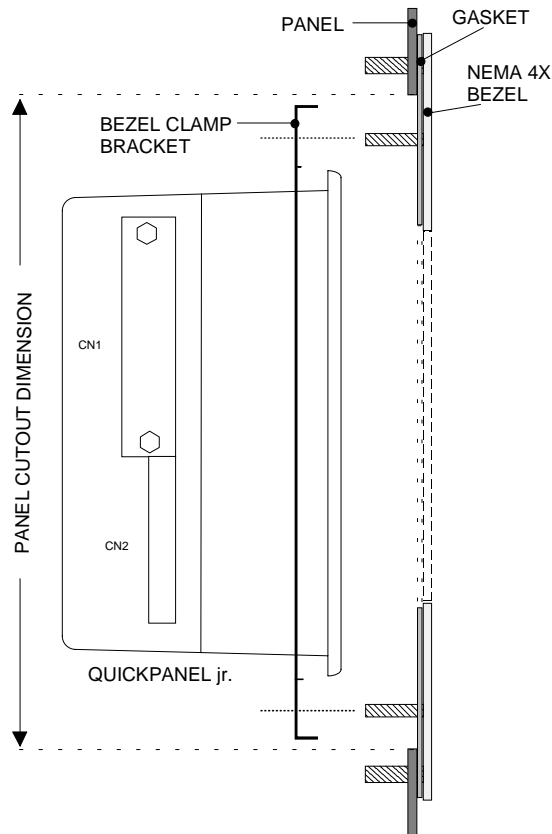

Panel Cutout

Use the following dimension drawings to layout and cut the opening in your panel. The dashed line in the drawing is the panel cutout. Mark and drill the $\frac{7}{32}$ " holes for securing the bezel to the panel. Note that the hold down bracket fits inside the cutout.

HMI-BEZ-201: Bezel for 5" Displays

Use the following bezel drawing *ONLY* for the following displays:
QPJ-2xxxx-xxx

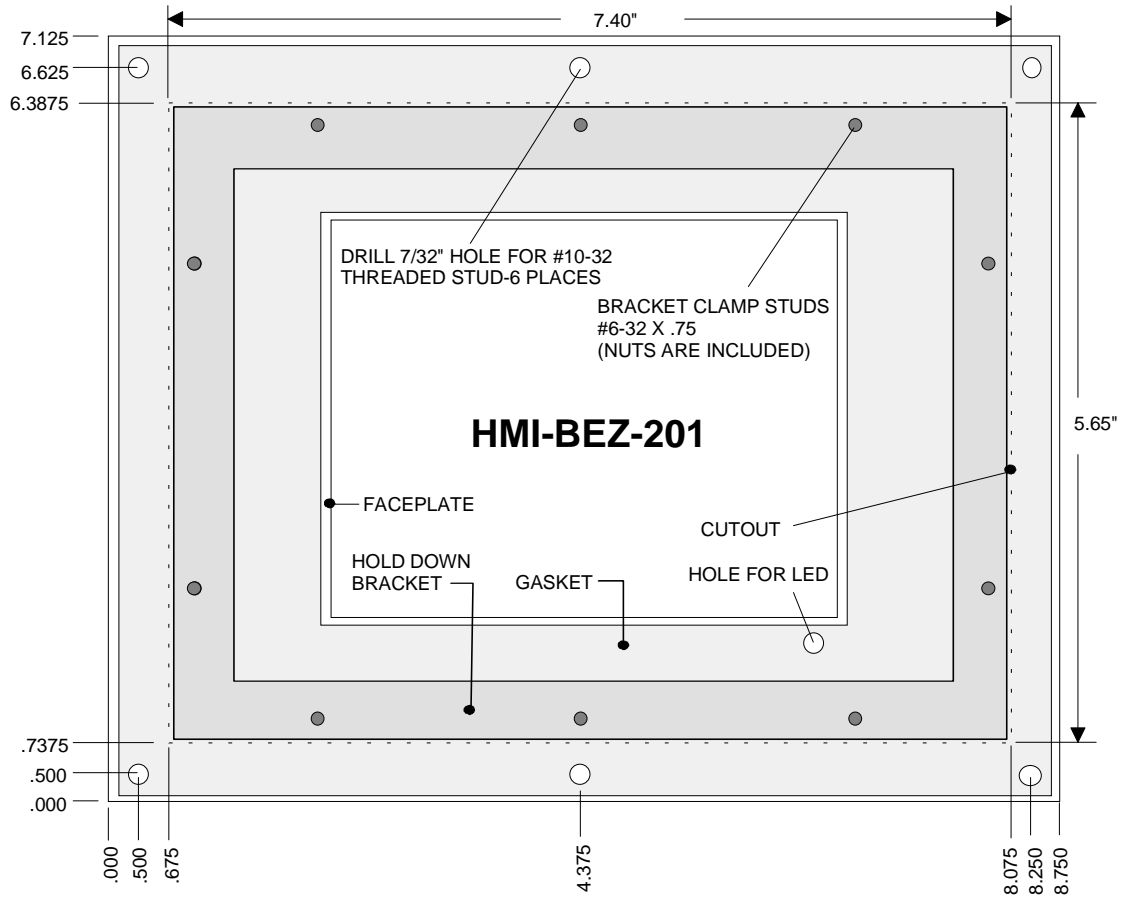

HMI-BEZ-202: Bezel for 9" Monochrome EL

Use the following bezel drawing *ONLY* for the following display:
QPI-2xxxx-Exx

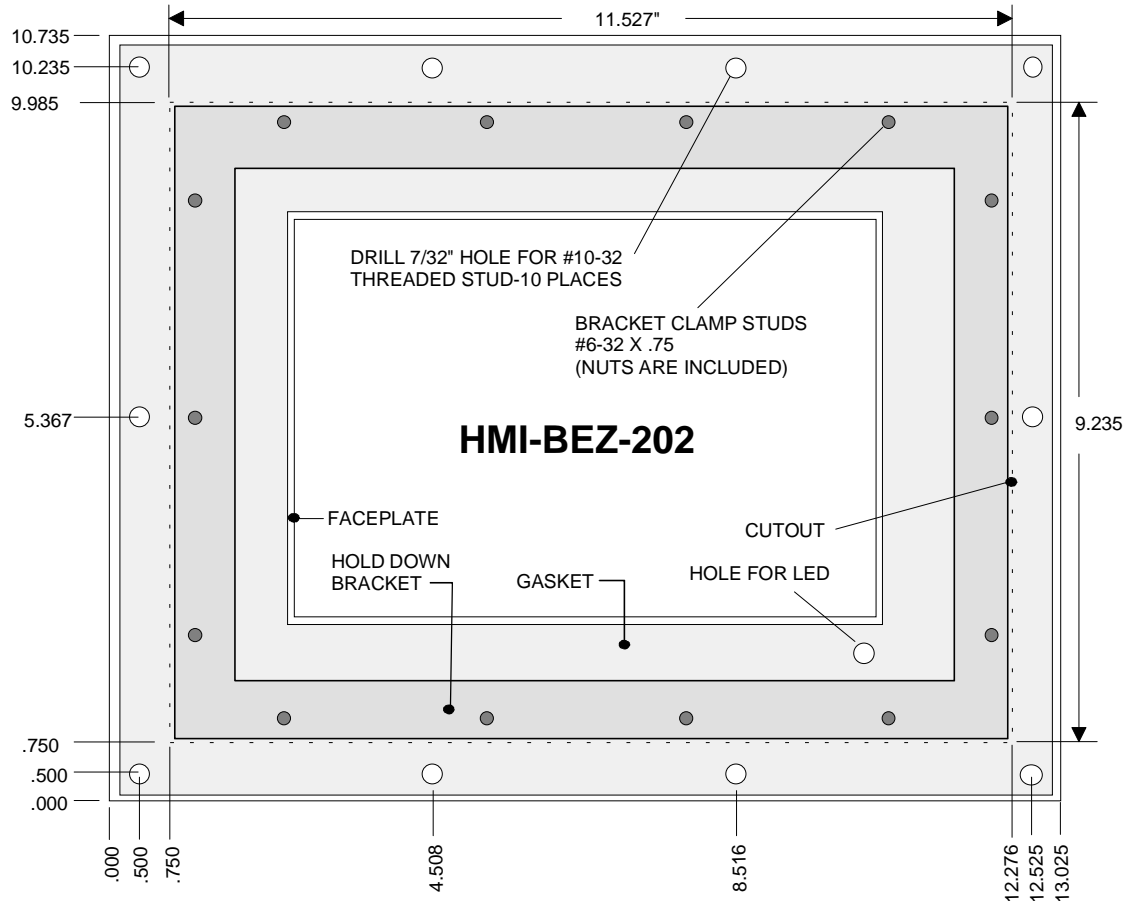

HMI-BEZ-203: Bezel for 10.5" Color Displays

Use the following bezel drawing *ONLY* for the following displays:

QPI-2xxxx-Sxx

QPI-2xxxx-Cxx

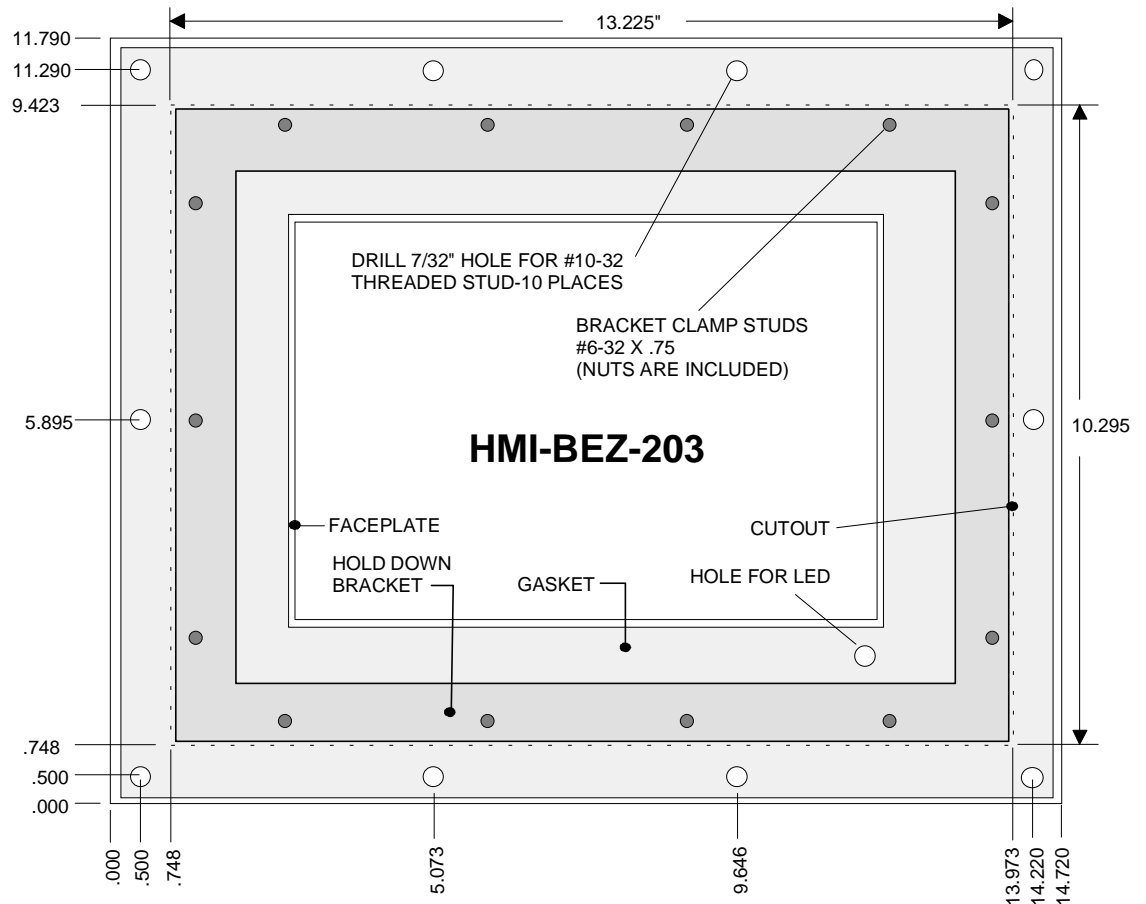

HMI-BEZ-204: Bezel for 6" Displays

Use the following bezel drawing *ONLY* for the following displays:
QPK-2xxxx-xxx

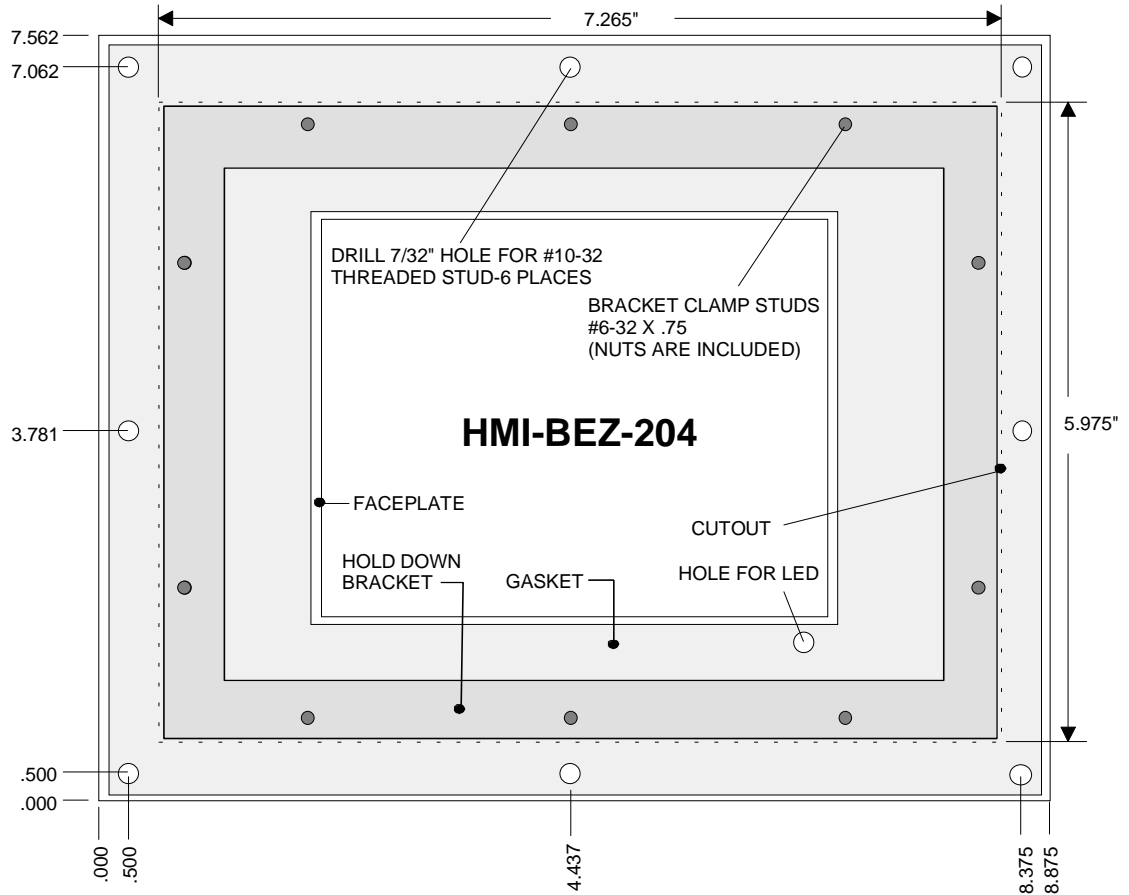

HMI-BEZ-205: Bezel for 12.1" Displays

Use the following bezel drawing *ONLY* for the following displays:
QPL-21100-C2P

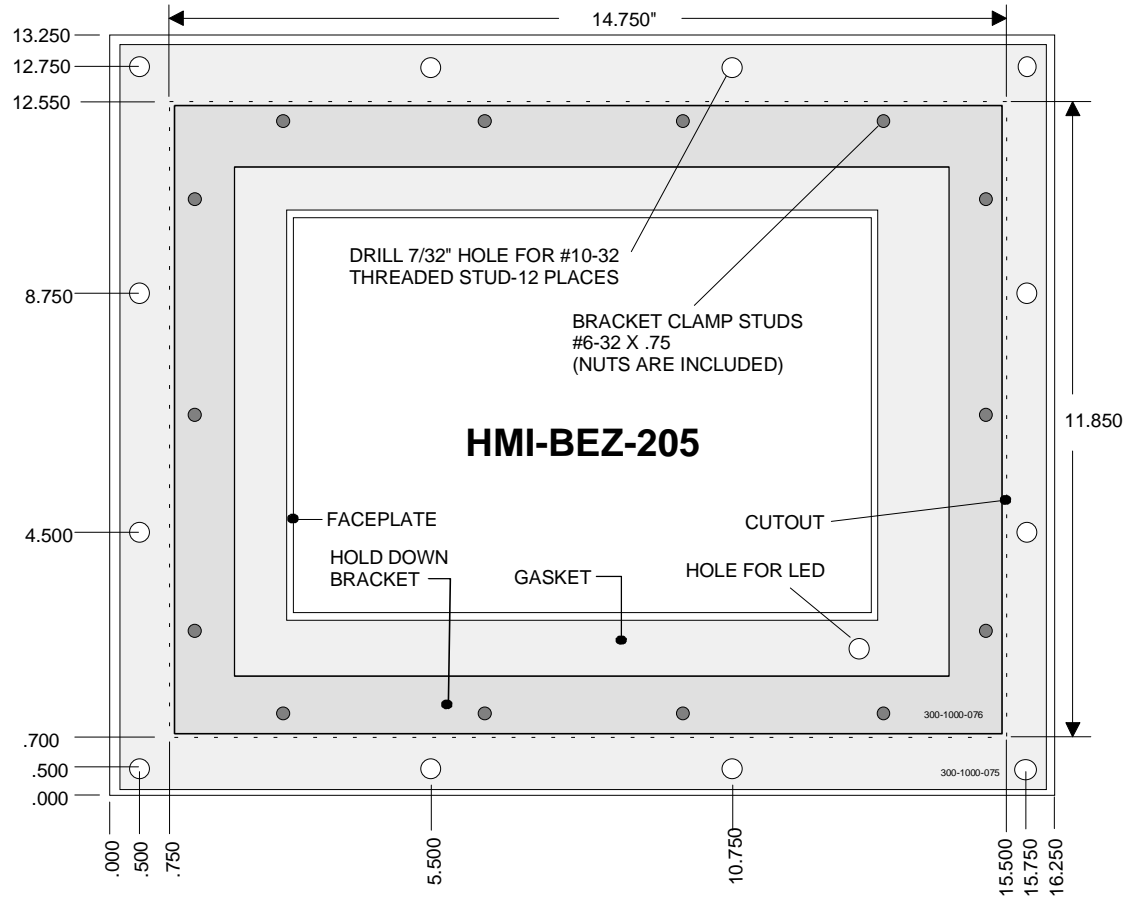

Assembly Procedure

Place the bezel face down on a non-abrasive surface. Place the display against the gasket and make sure the LED on the faceplate aligns with the hole in the gasket and bezel.

Make sure the LED on the display aligns with the hole in the bezel.

Place the clamp bracket over the display and install the nuts on the studs. Finger tighten the nuts. Check the alignment of the LED hole then tighten the nuts.

Make sure the clamp bracket is positioned as shown in the drawing.

Insert the bezel assembly into the panel cutout and install the 10-32 nuts.

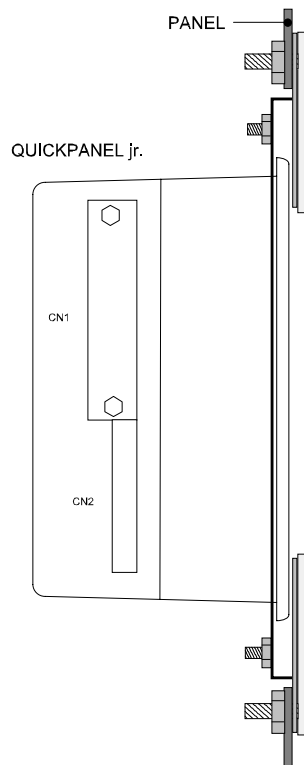

Color/EL Panel Adapter

The HMI-ADP-001 Panel Adapter allows using an EL Unit in the Color Unit panel cutout. The front adapter plate slips into the panel cutout made for a color unit. The rear adapter plate is then bolted to the front adapter plate. The hole in the adapter plates will exactly fit the EL unit.

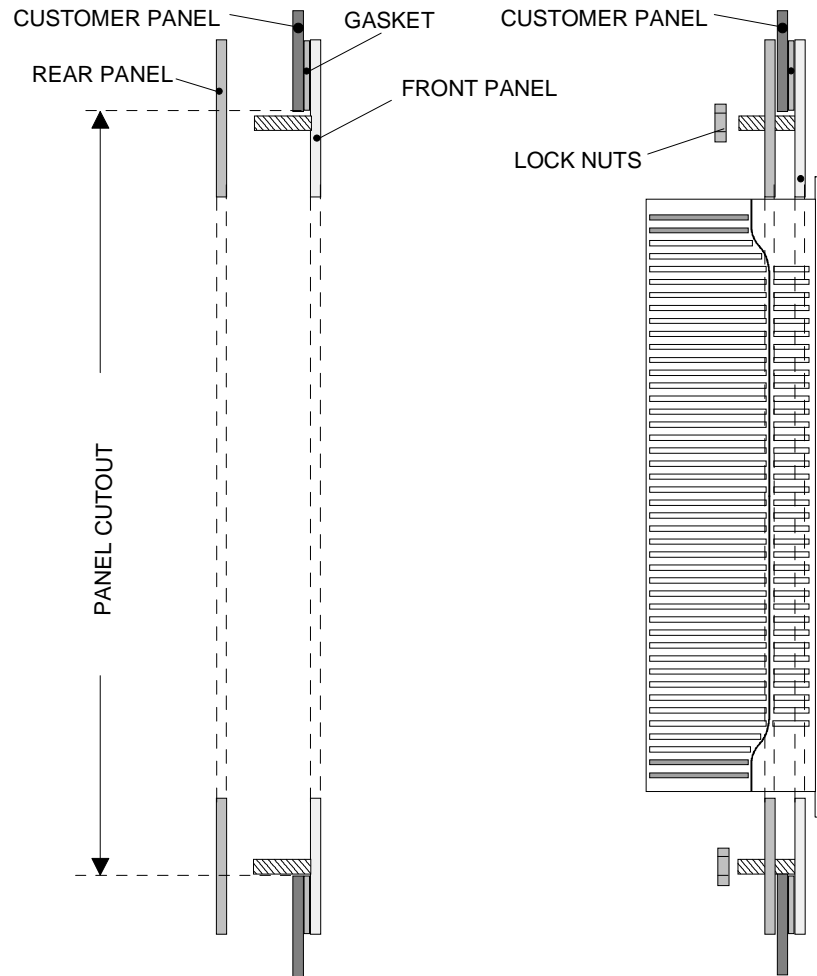

Communication Options

Installing an Option Module on a *QUICKPANEL jr.*

Modules are installed by aligning the option module connector on the option module to the connector on the display and pressing the two units together firmly. The option module is secured by four screws.

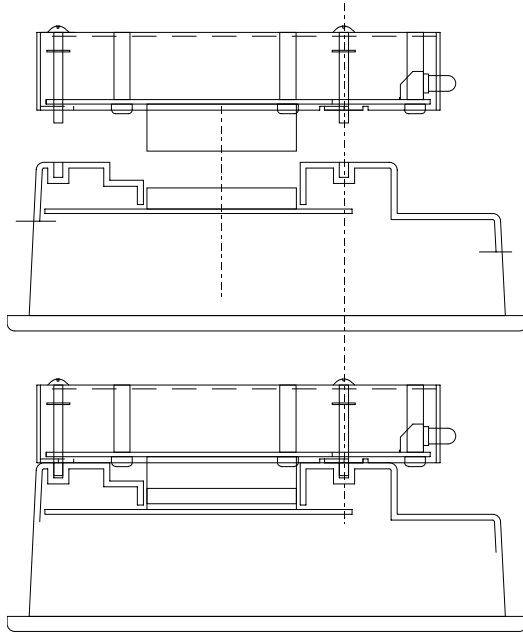

NOTE

Make sure you connect the ground wire from the module to the ground connection on the power terminal.

Installing an Option Module on a *QUICKPANEL*

Remove the option module cover plate. Insert the option module tabs into the mating slots in the display chassis. Align the option module connector with the mating connector on the display. Press the module firmly into the display chassis and tighten the screws.

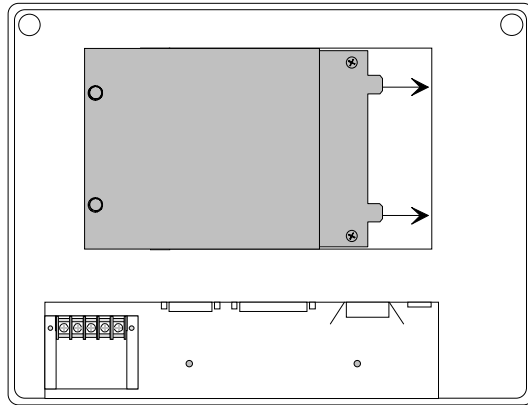

A-B Remote I/O Module

A-B Remote I/O Module for the QUICKPANEL jr.

The Remote I/O interface module for the QUICKPANEL jr. is shown below.

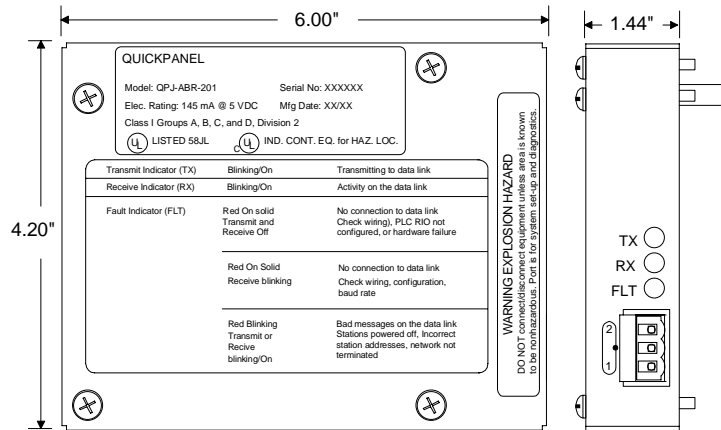

A-B Remote I/O Module for the QUICKPANEL

The Remote I/O interface module is shown below.

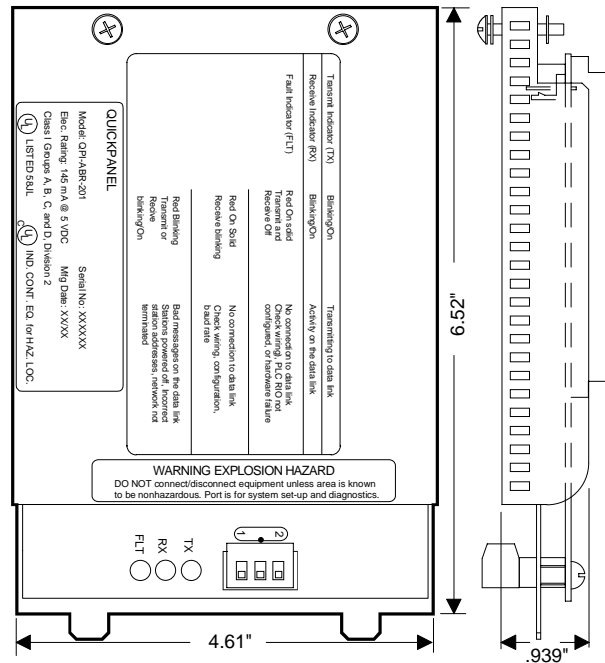

A-B Remote I/O Operation

The Remote I/O module is supplied with a screw-terminal connector block. The terminal block is a standard Remote I/O wiring connector.

The RIO network must be connected in daisy chain fashion. This is done by connecting devices in a serial manner from one device to the next. This method requires that you never attach more than two cables to any one device. Special connectors are required to connect each device.

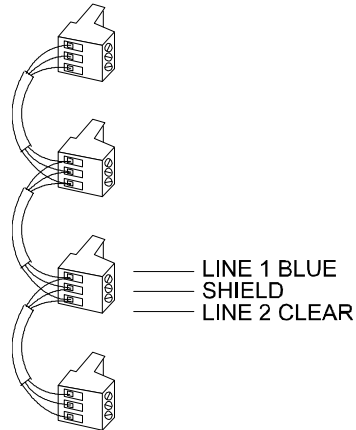

There are no restrictions governing the spacing between each device, as long as the maximum cable distance is not exceeded. The maximum cable distance is dependent on the Baud Rate of the network.

57.6KBaud	3050 meters (10,000 ft.)	150 ohm
115.2KBaud	1525 meters (5000 ft.)	150 ohm
230.4KBaud	750 meters (2500 ft.)	82 ohm

Remote I/O wiring requires termination at each end of the cable between the BLUE Line 1 and CLEAR Line 2 wires. The shield wire must be connected to chassis ground only at the scanner end of the RIO network. Refer to Allen-Bradley documentation for details.

A-B Data Highway Plus Module

A-B Data Highway Plus Module for the *QUICKPANEL jr.*

The A-B Data Highway Plus Module is shown below.

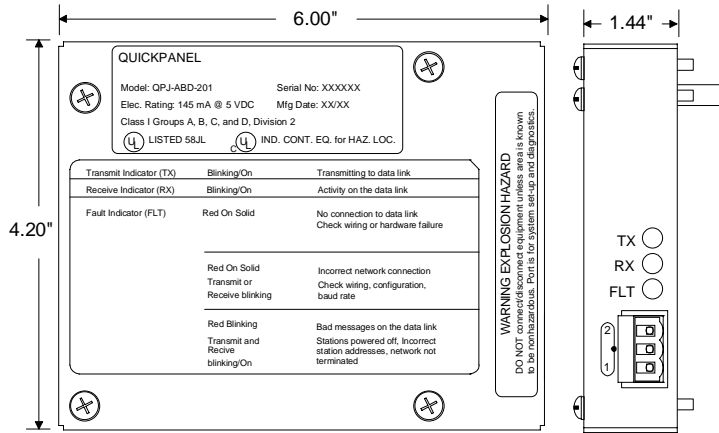

A-B Data Highway Plus Module for the *QUICKPANEL*

The A-B Data Highway Plus Module is shown below.

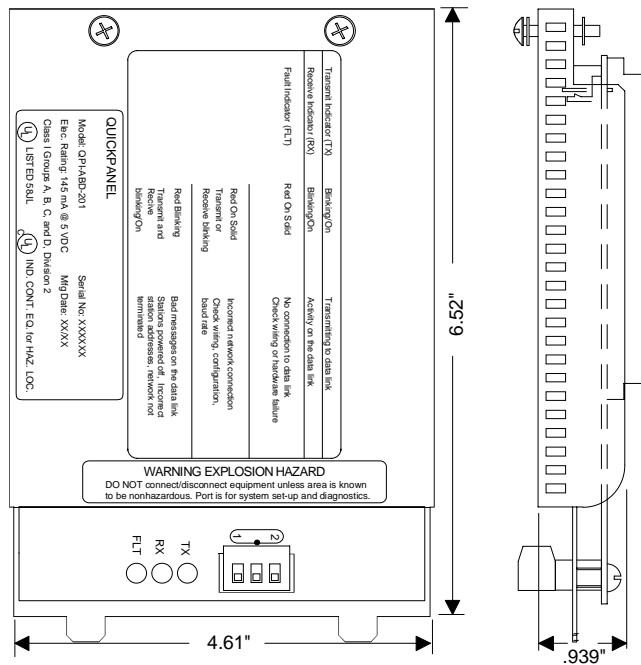

A-B Data Highway Plus Module Operation

The QUICKPANEL can communicate on the Data Highway Plus Local Area Network (LAN) through a serial port connection to an external Data Highway Plus Module or through a Data Highway Plus Module attached to the QUICKPANEL.

The following drawing illustrates a Data Highway Plus connection between a QUICKPANEL equipped with an optional Data Highway Plus Module and a PLC-5.

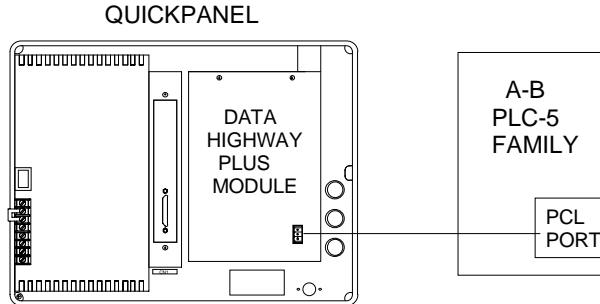

The following drawing illustrates a Data Highway Plus connection between a QUICKPANEL, a 1770-KF2/B and a PLC-5. The QUICKPANEL utilizes a serial connection to an A-B 1770-KF2 Interface Module. Some models of the PLC-5, such as the PLC-5/30, have a DF1 port that can be used for direct connection to the QUICKPANEL. Use an HMI-CAB-C51 cable to connect the QUICKPANEL to the 1770-KF2 Module.

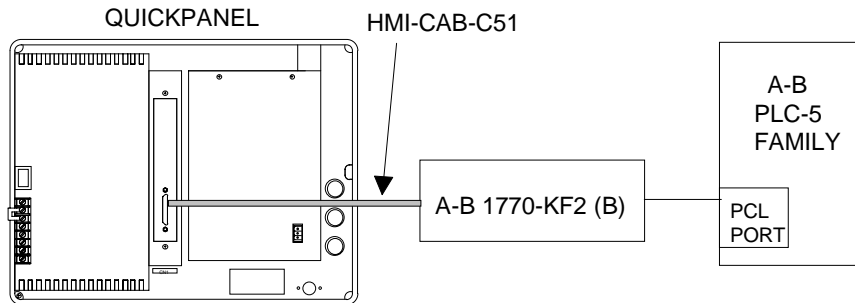

The following drawing illustrates a connection between a QUICKPANEL, a 1785-KE Module and a Data Highway Plus link. Use an HMI-CAB-C55 cable to connect the QUICKPANEL to the 1785-KE Module.

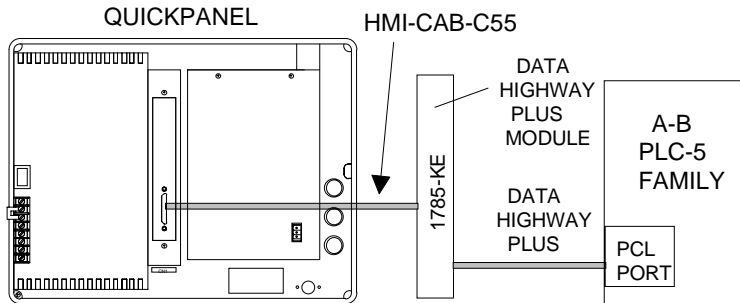

CANopen Module

CANopen Module on a *QUICKPANEL jr.*

Attach the power wires to the terminal block on the display. Align the option module connector with the mating connector on the display. Press the module firmly into the display chassis and tighten the screws. The option module is shown below.

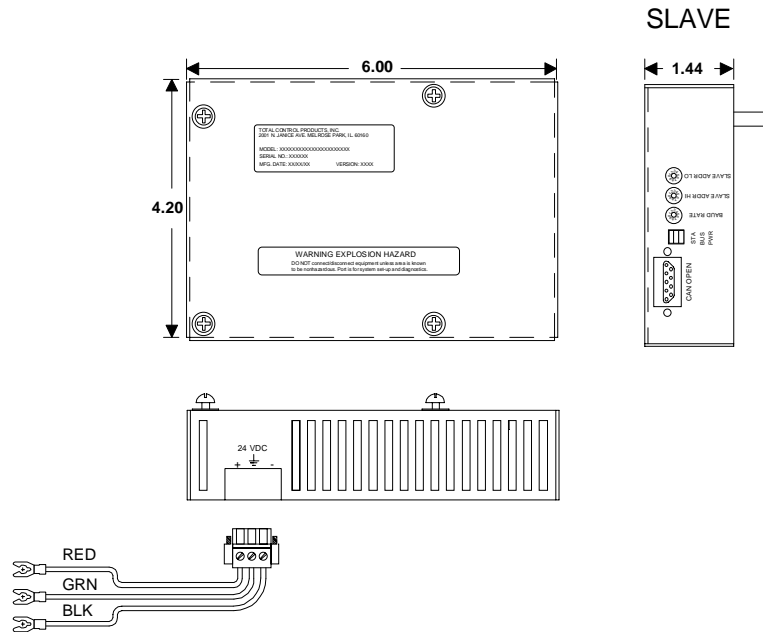

CANopen Module on a QUICKPANEL

The CANopen Module is shown below. The address and baud rate switches are located on the edge of the module. The legends for the connector and the switches are printed on the top of the module.

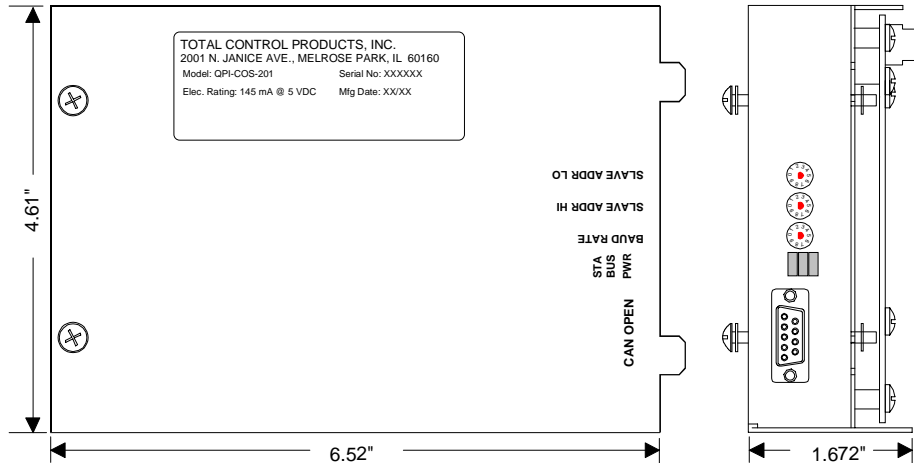

Module Configuration

The module can be configured by selecting the address and baudrate in the Protocol setup for Quick Designer. When the project is downloaded to the QuickPanel the module and the QuickPanel both become configured.

The module also supports Node Address and Baudrate setting via the rotary switches on the module.

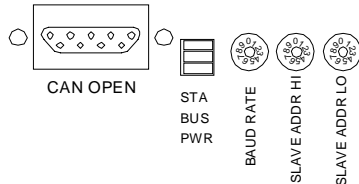

Address

The address setting is selected by two rotary switches marked Address High and Address Low

Node Address	Address High	Address Low
0	0	0
1	0	1
2	0	2
....		
61	6	1
62	6	2
63	6	3

Baud Rate

The Baud rate is selectable from 10 Kbps to 1 Mbps by the rotary switch marked Baud Rate.

Baud Rate	Rotary Switch
N/A	0
10K	1
20K	2
50K	3
125K	4
250K	5
500K	6
800K	7
1M	8
N/A	9

LEDs

There are three LEDs on the module to indicate module status. See the drawing below for the location of the LEDs. The three LEDs are:

STATUS	Red/Green	Red flashing: Recoverable fault Red solid: Critical module fault Green flashing: On-line but not connected Green solid: On-line, link okay, connected
BUS	Red	OFF: Address DIP switch is valid ON: DIP switch not valid
POWER	Green	ON = Power On OFF = Power OFF

Connector Diagram

9-pin D-sub	Signal	Description
1	--	reserved
2	CAN_L	CAN_L bus line (low)
3	CAN_GND	CAN ground
4	--	reserved
5	CAN_SHLD	CAN shield (optional)
6	GND	Optional ground
7	CAN_H	CAN_H bus line (high)
8	--	reserved
9	CAN_V+	Optional CAN external power supply.

If this is the last unit on the network, the network must be terminated with a 124 Ohm resistor between Pins 2 and 7.

There are three different baudrates for DeviceNet; 125k, 250k, 500kbits/s. Choose one of them by setting the DIP switch before configuring. When the DIP switch is in the ON position it is a logical "1". See the DIP switch drawing in this section. Set the switches to the ON position for software configuration.

Baudrate bit/s	Set DIP 1-2
125k	00
250k	01
500k	10
Reserved	11

There are three LEDs on the module to indicate module status. See the drawing below for the location of the LEDs. The three LEDs are:

ADDRESS	Red	OFF: Address DIP switch is valid ON: DIP switch not valid
STATUS	Red/Green	Red flashing: Recoverable fault Red solid: Critical module fault Green flashing: On-line but not connected Green solid: On-line, link okay, connected
POWER	Green	ON = Power On OFF = Power OFF

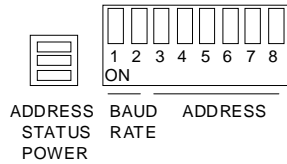

DeviceNet Module for the QUICKPANEL

Remove the option module cover plate. Insert the option module tabs into the mating slots in the display chassis. Align the option module connector with the mating connector on the display. Press the module firmly into the display chassis and tighten the screws.

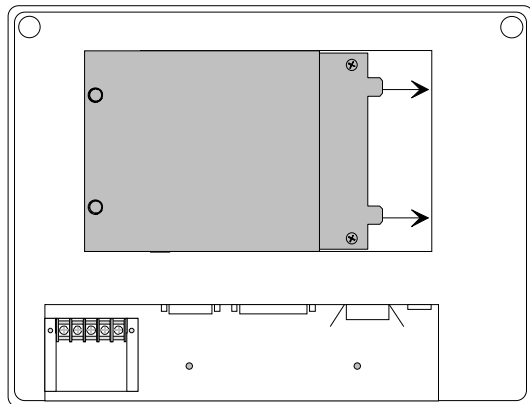

STATUS	Red/Green	Red flashing: Recoverable fault Red solid: Critical module fault Green flashing: On-line but not connected Green solid: On-line, link okay, connected
POWER	Green	ON = Power On OFF = Power OFF

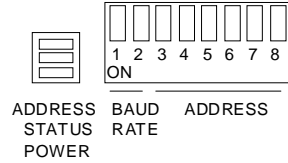

Fieldbus Connector

The CAN connector is a standard 5-Pin removable connector that conforms to the standard DeviceNet pinout. The connector and wire connections are shown below.

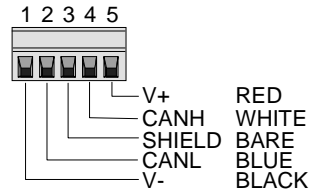

EDS File

The DeviceNet specification defines an *Electronic Data Sheet* (EDS) which is a simple file format that allows product-specific information to be made available by vendors for all other vendors. This makes possible user-friendly configuration tools that can be easily updated without having to constantly revise the configuration software tool. The EDS file is sent on diskette with each DeviceNet module. The diskette part number is 510-1000-054.

Modbus Plus Adapter Module

Modbus Plus Adapter Module (QUICKPANEL jr.)

The following drawing illustrates the Modbus Plus Adapter for a QUICKPANEL jr. display.

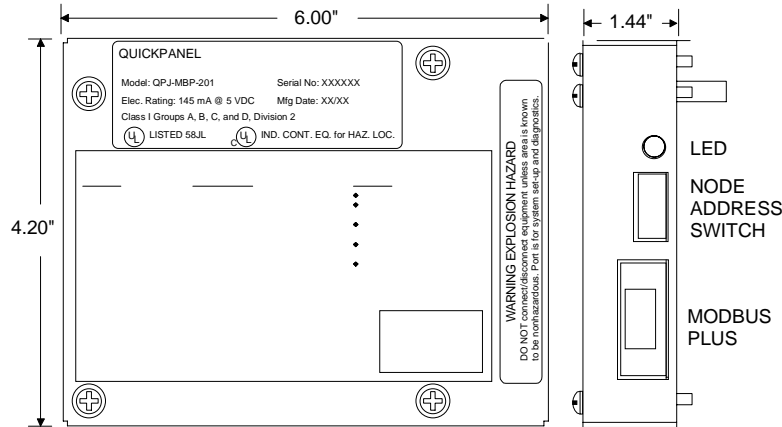

Modbus Plus Adapter Module (QUICKPANEL)

The following drawing illustrates the Modbus Plus Adapter for a QUICKPANEL display.

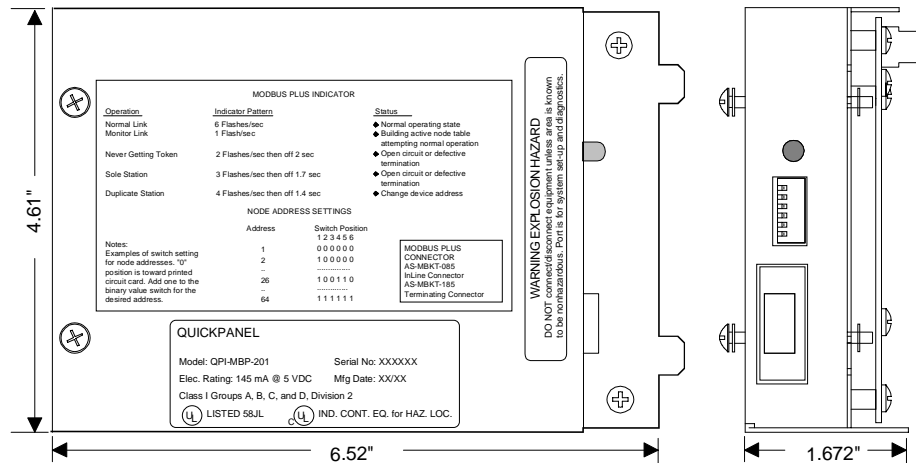

Modbus Plus Operation

Modbus Plus is a local area network system designed for industrial control applications. A network is a group of nodes on a signal path that is accessed by the passing of a token. A token is a group of bits that is passed in sequence from one device to another on a single network, to grant access for sending messages. While holding the token, a node initiates message transactions with other nodes. Each message contains routing fields that define its source and destination. A node is any device that is physically connected to the Modbus Plus cable. Up to 32 devices can connect directly to the network cable over a length of 1500 feet. Each node is identified by a unique address assigned by the user.

The network bus consists of twisted-pair shielded cable run in a direct path between successive nodes. The minimum cable length between any pair of nodes must be at least 10 feet. The maximum cable length between two nodes is the same as the maximum section length of 1500 feet. The node at each end of a section uses a terminating connector, which provides resistive termination to prevent signal reflections on the network bus. Terminating connectors have a molded shell that is light gray in color. The other nodes use an inline connector which is dark gray.

Network cables are NOT supplied by Total Control Products, Inc. Order the following cables from your Modbus Plus distributor.

Inline Connector, AS-MBKT-085

Terminating Connector, AS-MBKT-185.

Modbus Plus Network

Each node has an LED indicator that flashes patterns to show its status on the network. A simple network consists of two or more nodes connected to a single section.

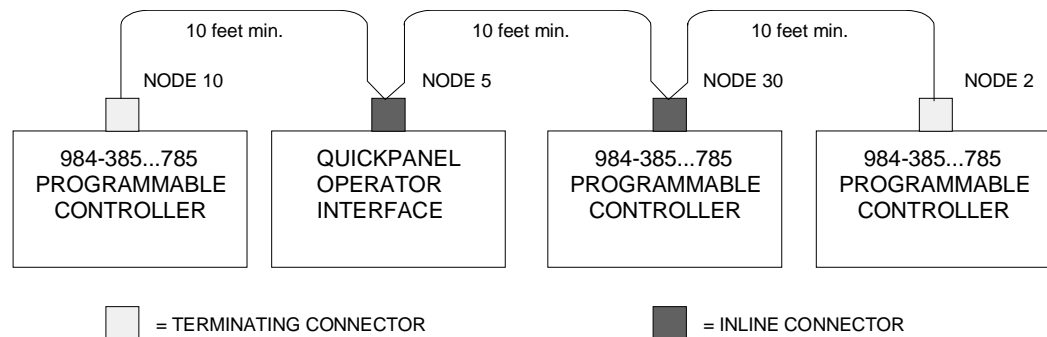

Diagnostic LED

The LED is controlled by the on-board processor and displays node status by flashing repetitive patterns.

Six flashes per second.	This node is working normally. Receiving and passing the token. All nodes should be flashing this pattern.
Flash every 1 sec.	Monitor Link Operation. This node is in the MONITOR_OFFLINE state, where it must monitor the link for 5 seconds, and it is not allowed to transmit any packets out onto the link.
2 flashes, off 2 secs.	Never Getting Token. This node is permanently in the MAC_IDLE. This node hears other nodes on the link pass the token to themselves, but the token is never passed to this node. This node may have a bad transmitter.
3 flashes, off 1.7 secs.	Sole Station. This node is not hearing any other nodes so it is periodically claiming and winning the token, and then finds there is no other node to pass it to. This node may have a bad receiver.
4 flashes, off 1.4 secs.	Duplicate Station. This node has heard a valid packet that was duplicate-node-address sent from another node on the link that is using the same link address as this node. This node is now in the DUPLICATE_OFFLINE state where it will remain passively monitoring the link, until the duplicate node is not heard from for 5 seconds.

Station Address Switches

Station Address	Switch Position					
	1	2	3	4	5	6
1	0	0	0	0	0	0
2	1	0	0	0	0	0
26	1	0	0	1	1	0
32	1	1	1	1	1	0
64	1	1	1	1	1	1

Note: add one to switch setting for desired address. Switch down = ON = 0.

Profibus Module

Profibus Module for the *QUICKPANEL jr.*

Align the option module connector with the mating connector on the display. Attach the power wires to the terminal block on the display. Press the module firmly into the display chassis and tighten the screws. Plug the power connector into the module. The option module is shown below.

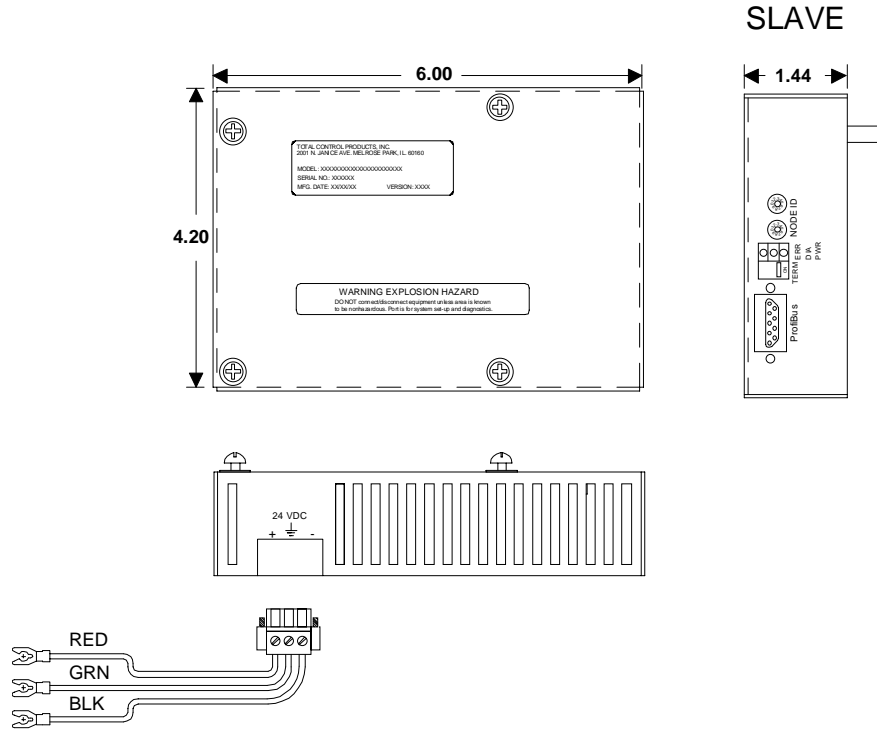

Profibus Module for the *QUICKPANEL*

The Profibus module is shown below. The module contains a terminator switch marked **TERM**. Move the switch to the ON position to enable the terminator resistors. Use the two rotary switches to set the **NODE ID** address.

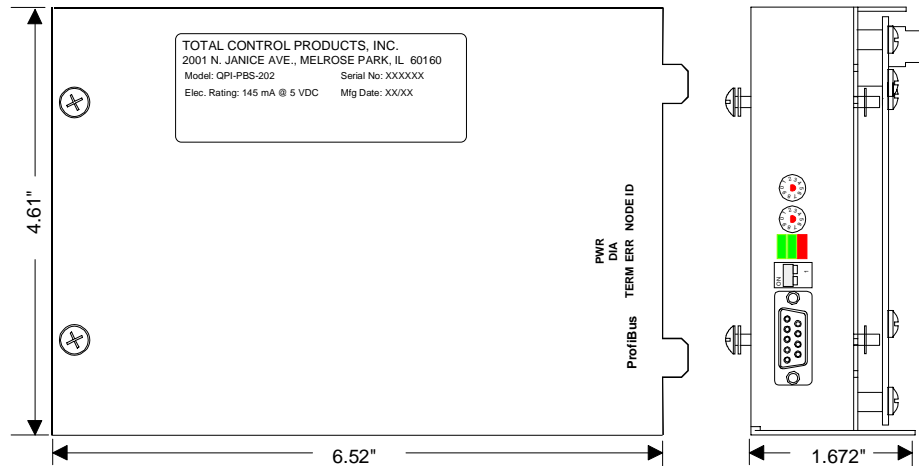

The three LEDs indicate power status (PWR), diagnostics (DIA), and error condition (ERR).

ERR	OFF= Normal Operation ON=Bus is OFF or has an error
DIA	Not used
POWER	ON=Power On OFF=Power OFF

NODE ID The rotary switch on the left is the x10 digit and the switch on the right is the x1 digit. Therefore, if the left switch is set to 5 and the right switch is set to 3, then the address is 53.

GE Genius Adapter Module

GE Genius Adapter Module (QUICKPANEL jr.)

The following drawing illustrates the GE Genius Adapter for a QUICKPANEL jr. display.

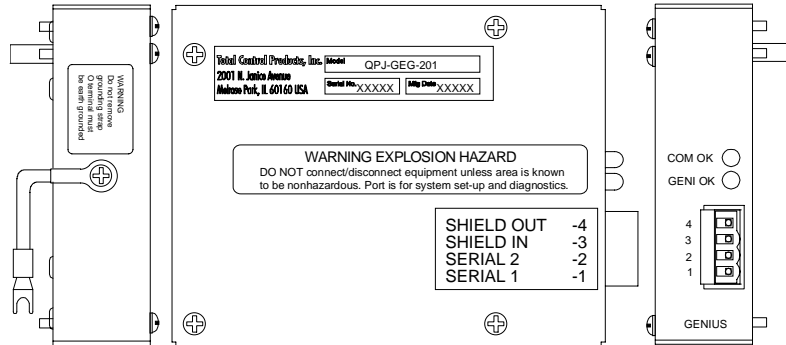

GE Genius Adapter Module (QUICKPANEL)

The following drawing illustrates the GE Genius Adapter for a QUICKPANEL display.

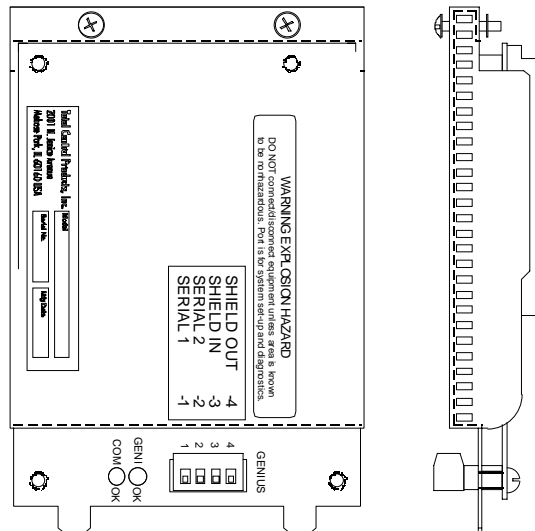

GE Genius Module Dimensions

For QUICKPANEL jr.

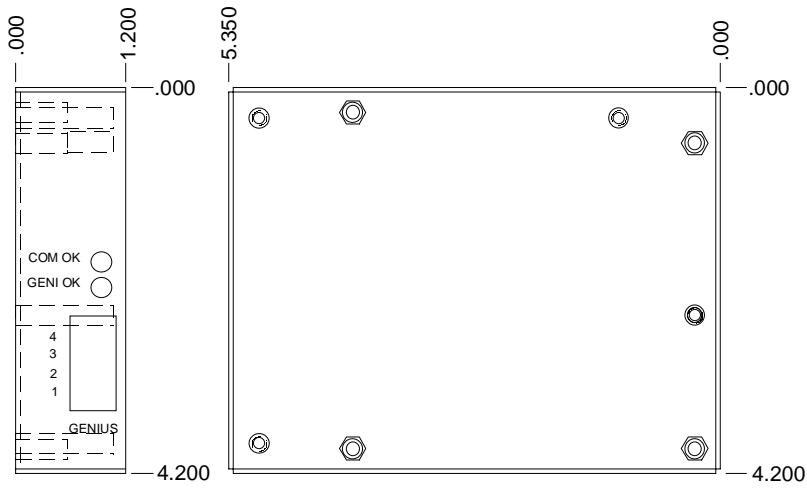

For QUICKPANEL

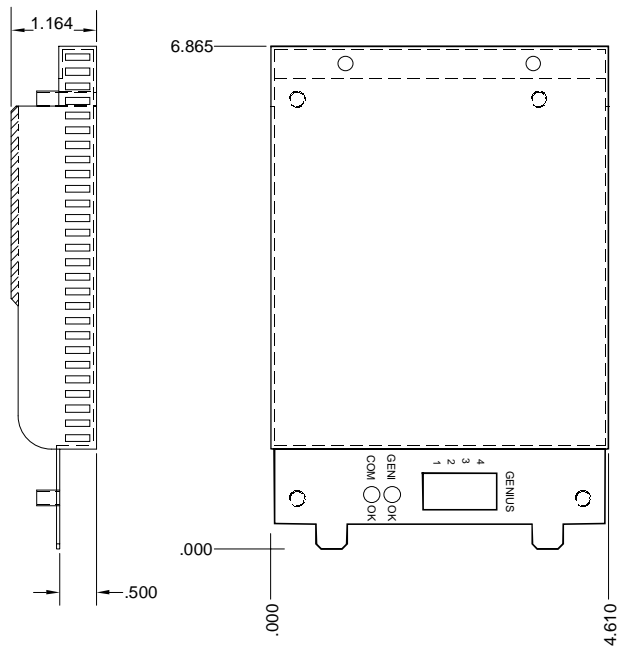

Cable Connection

Connect the devices as described below.

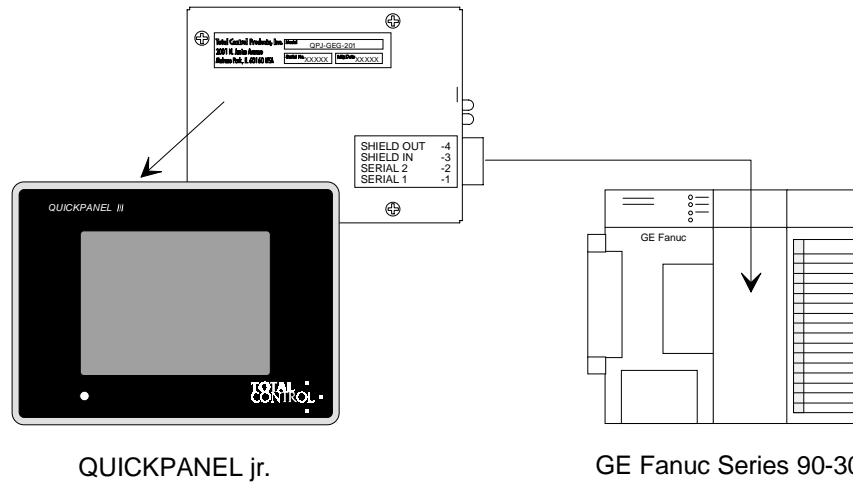

QUICKPANEL jr.

GE Fanuc Series 90-30

CAUTION

The bus shield wires are not insulated; do not permit them to touch other wires or terminals. Spaghetti tubing should be used to cover these wires.

Connect Serial 1 terminals of adjacent devices and the Serial 2 terminals of adjacent devices.

Connect Shield In to the Shield Out terminal of the previous device. (For the first device on the bus, Shield In is not connected.)

Connect Shield Out to the Shield In terminal of the next device. (For the last device on the bus, Shield Out is not connected.)

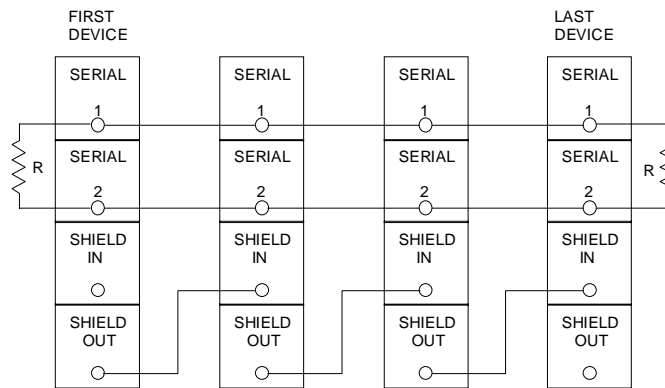

For more information about the operation of the GE GENIUS module, see the Communications User manual.

Interbus-S Module

I/O Network Operations

Network for I/O devices on an INTERBUS-S network are automatically determined by their physical position in the network. This eliminates the need for manually setting device addresses. The INTERBUS-S controller board performs an identification cycle (ID) to determine the addresses. After the ID cycle is completed, the host control verifies the network configuration. Once verified, the network is ready for operation.

The INTERBUS-S controller board connects to many types of PLC or computer-based host controllers. The controller board performs all network functions independent of the host controller. Advanced features of the INTERBUS-S controller board include peer-to-peer communications, event processing, and logical addressing.

Connectors

Cable assemblies, cable and connectors can be obtained from several manufacturers. To avoid intermittent communications on the network, always connect DO and /DO via the same twisted pair. Likewise, always connect DI and /DI via the same twisted pair. In addition, always connect both ends of the cable shielding to their respective connector housings or shield connection. A connection of 24 volts to data lines will permanently damage the module.

Remote Out

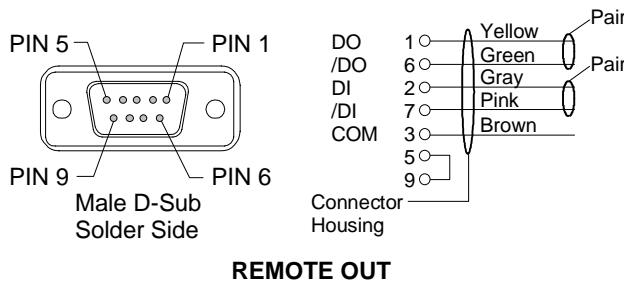

Remote In

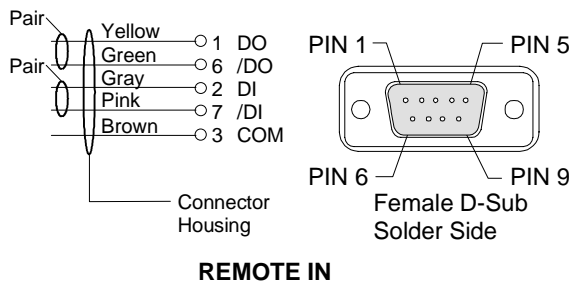

PLC Comm Errors

In the event of a communication problem, error messages are displayed on a status line at the bottom of the display.

Error Displayed Definition

PLC COMM ERROR (02:FF:A0) Error initializing Anybus module

PLC COMM ERROR (02:FF:01) Incorrect Anybus module ID

PLC COMM ERROR (02:FF:02) Anybus module watchdog time-out (module lockup)

PLC COMM ERROR (02:FF:03) Network Error - Network not connected

Installing a Interbus-S Module on a QUICKPANEL

Remove the option module cover plate. Insert the option module tabs into the mating slots in the display chassis. Align the option module connector with the mating connector on the display. Press the module firmly into the display chassis and tighten the screws.

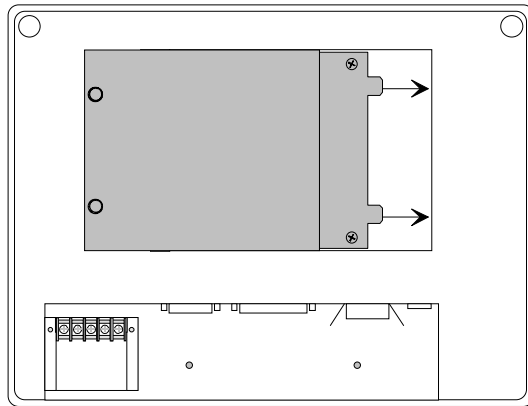

Interbus-S Module Options

The Interbus-S module is shown below.

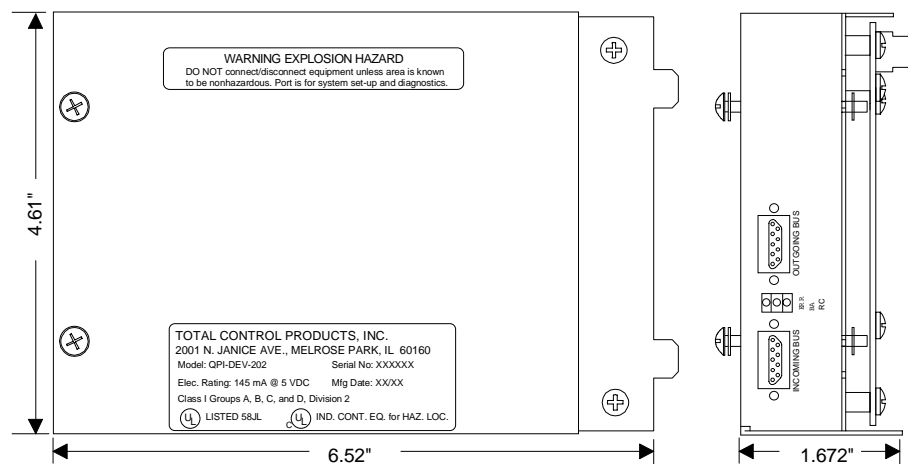

Keypad Option

This section covers the installation steps for the HMI-KPN-201. The installation steps are essentially the same for the HMI-KPN-301 and HMI-KPN-302.

The keypad option adds 41 external keypads to extend the functionality of the QuickPanel. There are programmable keypads around the touchscreen and a data entry keypad. Instead of touching the QuickPanel screen to activate a Push Button, you can press an external keypad. You can also assign an external keypad to simulate a push button, selector switch, goto panel button, numeric data entry, print button or word button. Simulating operators saves screen space. The following picture shows the HMI-KPN-201 keypad for use with 5" and 6" displays.

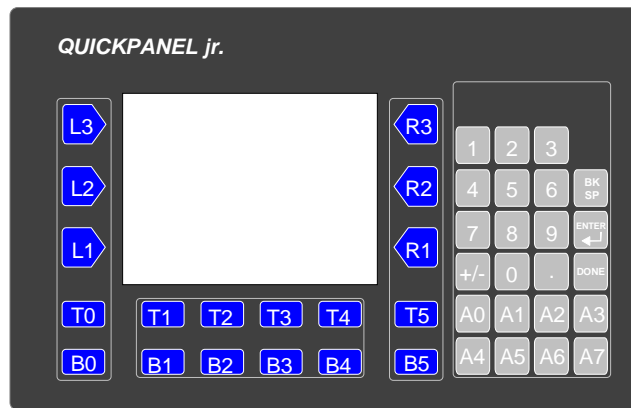

The optional keypad for QuickPanel displays is available in several versions:

HMI-KPN-201	5" and 6" Displays
HMI-KPN-301	9" displays
HMI-KPN-302	10.5" displays

Features:

- 26 Programmable Keypads
- Numeric Keypad (Reserved Keys)
- Removable Legends
- Keypads can simulate panel operators
- Keypads can be assigned to screen operators

The following panel operators can be assigned to external keypads:

Push Button
Illuminated Push Button
Numeric Data Entry (with external numeric keypad)
Selector Switch
Word Button
Goto Panel Button
Print Button
Alarms

When you add the external keypad to the standard touch screen, the panel operators can be made to operate in several modes. For example, a Push Button can:

- work normally without using an external keypad.
- be assigned to an external keypad.
- work normally and with an external keypad.
- be simulated by a keypad but not appear on the touch screen.

The keypad designations are PERMANENTLY assigned, but the physical legends can be changed to suit your application. That is, L3 will always be in the same physical location, but the legend for L3 can be changed.

The keypads are divided into Reserved keys and Programmable keys. All of the keypads around the display area are designated Programmable keys. The keypads A0 thru A7 are programmable but are primarily used with Alarms. The numeric keypads, including the blank keys above the numeric keypads cannot be assigned and are designated as Reserved.

Keypad models HMI-KPN-301 (for 9" QuickPanels) and HMI-KPN-302 (for 10.5" QuickPanels) must be configured with QuickDesigner version 3.4 and higher.

When using the HMI-KPN-301 or HMI-KPN-302 keypad with any 'Series 2' QuickPanel (i.e. QPI-2xxxx-xxx), QuickDesigner version 3.4 requires a software update. This update can be downloaded from the Total Control Products web site at www.total-control.com. This update will not be required for QuickDesigner versions higher than version 3.4.

Keypad Installation

A rear view of the keypad assembly is shown below. The keypad encoder cover is shown removed. JU2 jumper is used to enable/disable the keypad beeper. The factory installs the jumper to enable the beeper.

The mask is designed to allow for differences in screen sizes between the 5" display and the 6" display. The mask is left in place for 5" displays and removed for 6" displays. To remove the mask, simply lift an edge and break the mask off at the perforation line. Remove the two mounting bars and screws.

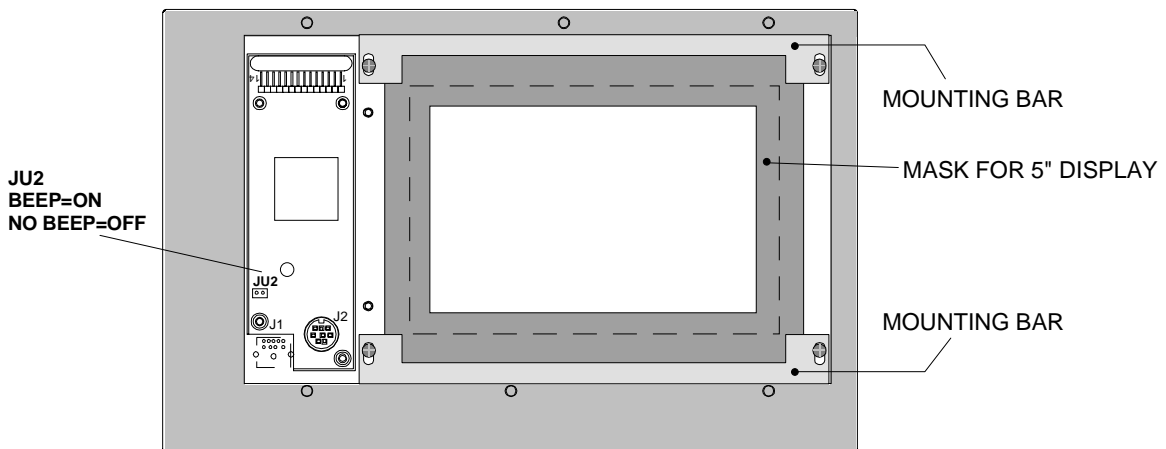

Use the panel clamps supplied with the QuickPanel to attach the mounting bars to the top and bottom of the QuickPanel. Make sure the mounting bars fit snug against the QuickPanel case. Finger tighten the panel clamps.

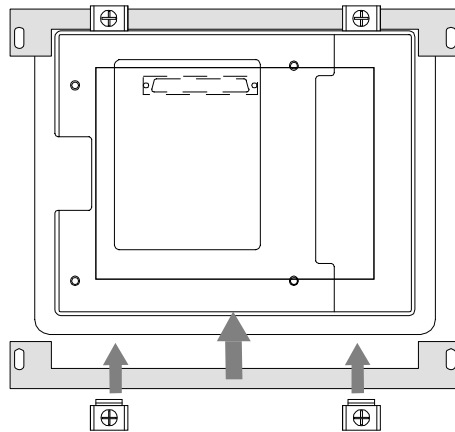

The overlay on the keypad assembly will cover the touch screen so the touch screen and the back of the overlay must be cleaned before assembly.

If you are installing a 6" display, make sure the mask is removed so that the entire screen is visible.

Insert the QuickPanel with mounting bars onto the back of the keypad assembly. Make sure the top of the display is located at the top of the keypad assembly. Install the mounting bar screws. Finger tighten the screws.

Verify the QuickPanel is centered in the keypad assembly. Tighten the panel clamp screws first, then tighten the mounting bar screws.

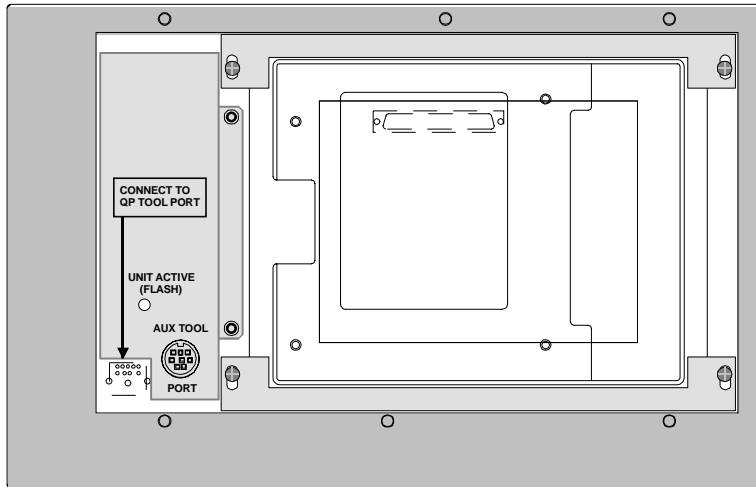

CAUTION

You **MUST** use the panel clamps to secure the QuickPanel to the mounting bars. Failure to use the clamps will cause premature failure of the overlay and the keypads.

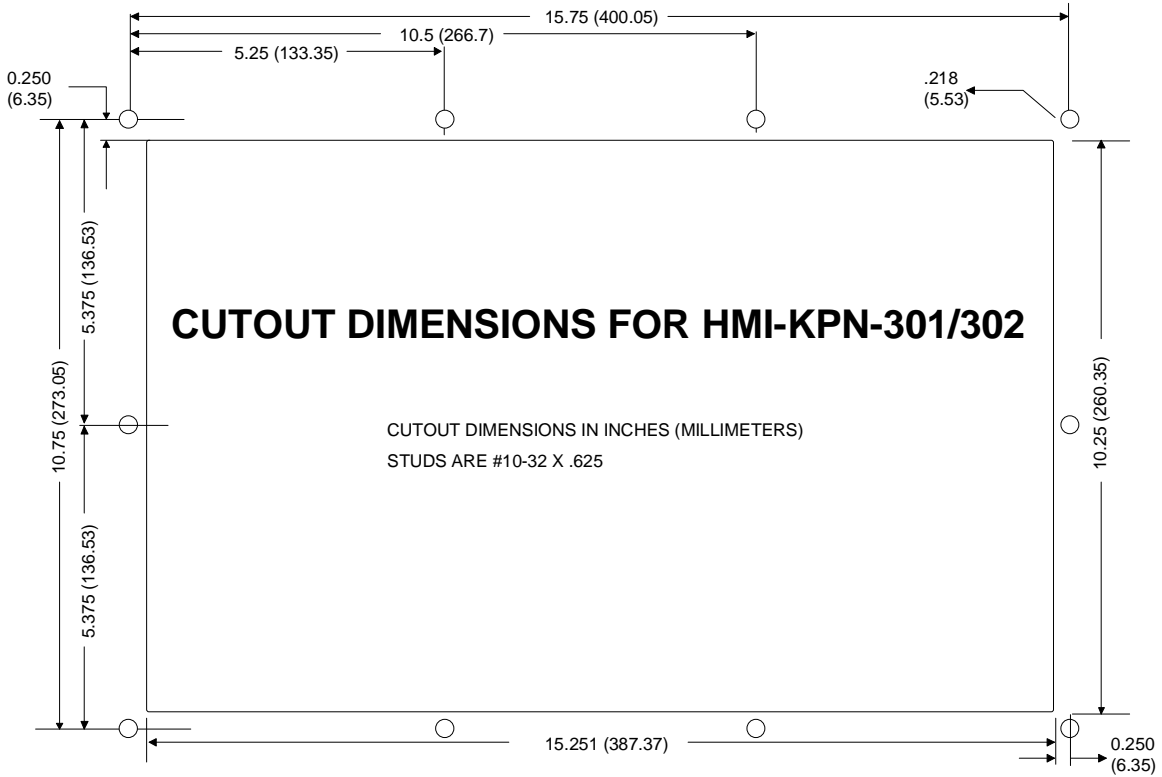

PANEL CUTOUT FOR HMI-KPN-301 and HMI-KPN-302 (9" and 10.5" displays)

Keypad Cable Connections

A short cable is used to connect the keypad encoder to the QuickPanel. One end of the cable is 9-pin and the other is 8-pin. The 9-pin connector is inserted into the down-facing jack labeled (CONNECT TO QP TOOL PORT), while the 8-pin connector is inserted into the QuickPanel tool port. The 8-pin connector on the keypad encoder labeled (AUX TOOL PORT) is used to connect a download cable or printer.

Install the short cable between the keypad encoder and the QuickPanel tool port as shown below.

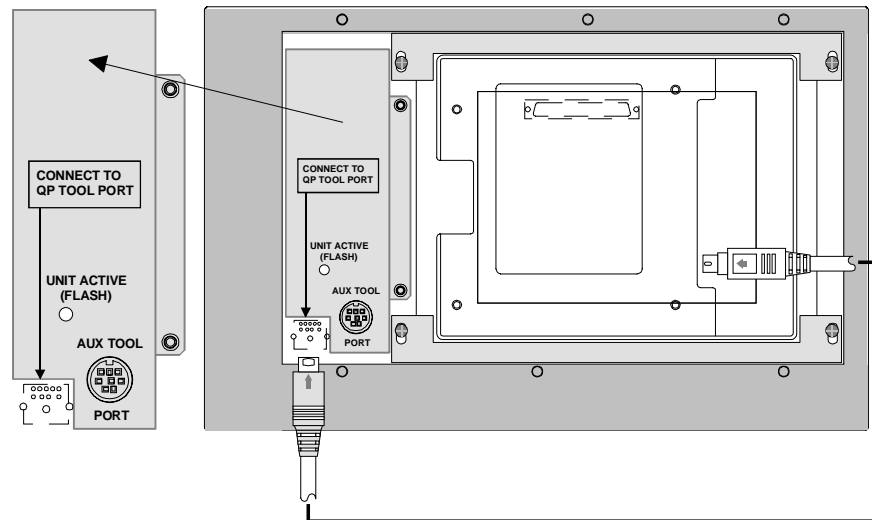

Attach the +24VDC leads to the display. Apply power and verify the LED (UNIT ACTIVE) on the keyboard encoder is blinking.

To download a file to the QuickPanel, connect the download cable to the AUX TOOL PORT on the keypad encoder. Do not press any keypads while downloading files. You can also disconnect the short cable from the QuickPanel tool port and connect the download cable to the tool port. This method ensures no interruptions to the download operation.

See the Quick Designer Panel Editor user manual, part number 800-1000-081, for instructions on assigning keypads to touch screen operators.

Dimensions

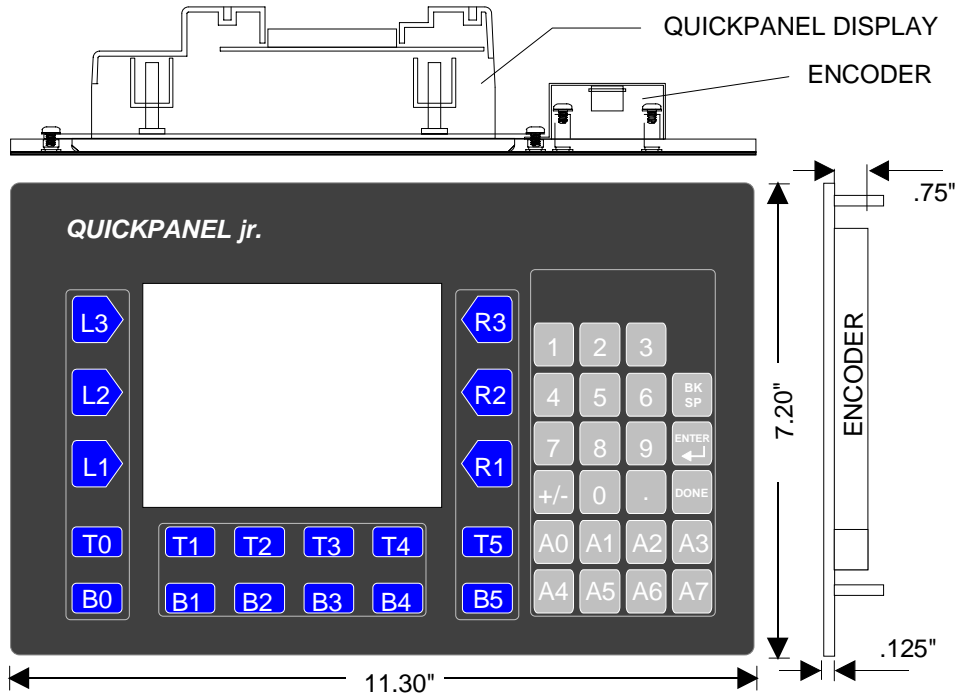

DIMENSIONS FOR HMI-KPN-201 (5" and 6" displays)

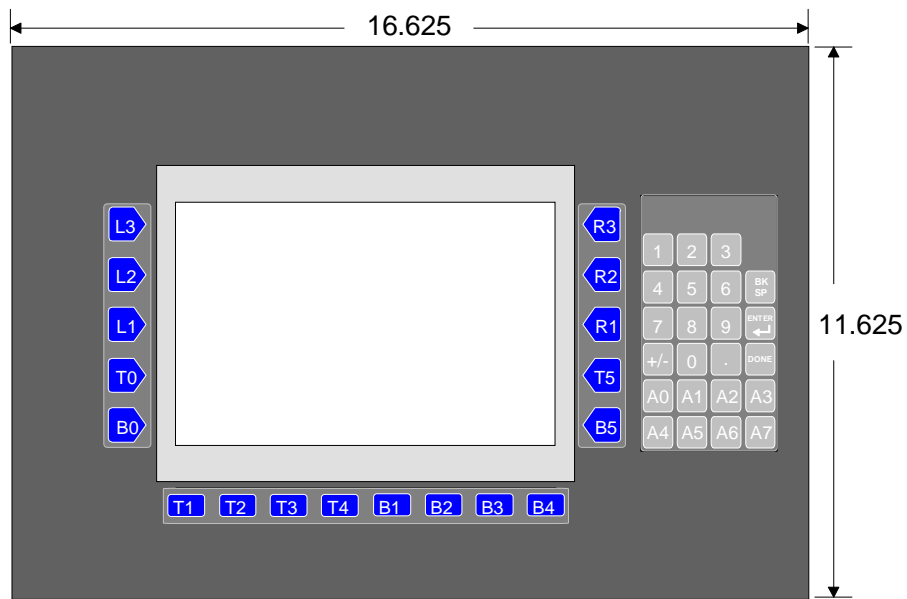

DIMENSIONS FOR HMI-KPN-301/302 (9" and 10.5" displays)

Maintenance Procedures

Mean Time Between Failures (MTBF)

The Mean Time Between Failures (MTBF) for the QuickPanel family of operator interfaces is calculated to be in excess of 75,000 hours, and the experienced-based MTBF is over 100,000 hours.

Model Numbers:
QPM-2D100-L2P
QPJ-xD100-x2P
QPK-xD100-x2P
QPH-2D100-x2P
QPI-xxxx0-x2P
QPL-2xx00-C2P

Replacing the Backlight Lamp

The backlight is a small florescent tube mounted near the top of the display screen. The part numbers for the backlight tubes are:

10.5" Color STN (QPI-2xxxx-Sxx or TFT QPI-2xxxx-Cxx)	HMI-CCT-201
5" Color or Monochrome (QPJ-2xxxx-xxx)	HMI-CCT-202
6" Color or Monochrome (QPK-2xxxx-xxx)	HMI-CCT-203
12.1" Color (QPL-21100-C2P)	HMI-CCT-205

The 6" TFT backlight is not field replaceable, however, it is rated at more than 50,000 hours. When the CCFL tube eventually fails, the power indicator on the front of the unit turns orange and the touch screen is disabled. The field replaceable backlight on the other 5" and 6" models is rated for 20,000 hours.



CAUTION

Use caution when opening this unit. Make sure the power has been turned OFF.

Allow the unit to cool before removing the backlight lamp.

High voltages are present when the power is ON.

1. Place the unit face down on a surface that will not scratch the front face. Use a small screwdriver to unfasten the two screws at the upper rear sides of the unit.
2. Slowly pivot the rear panel open. It will support itself in the nearly vertical position.
3. Disconnect the lamp connector. Remove the clamp screw from the left side of the lamp and remove the lamp. The lamp is press fit and may require some small force to remove it.
4. Insert the new lamp and reconnect the connector.
5. Replace the rear cover and tighten the screws. Be careful not to get any wiring caught between the front of the unit and the back cover.

Replacing the Touch Screen Overlay

The touch screen is made of a tough, flexible material that can withstand many chemicals and hard use. After repeated use, the overlay may get scratched or damaged. It can be replaced by simply peeling off the old overlay and carefully installing a new one. Contact the factory for part numbers and prices.

1. Locate the starter hole in the lower left corner.
2. Peel up the corner of the overlay using a small pick.
3. Carefully peel the overlay from the unit.
4. Remove the backing material from the new overlay.
5. Align the overlay, making sure the LED hole is placed over the LED.
6. Press the overlay in place.

Touch Screen Covers

The touch screen is made of a tough, flexible material that can withstand many chemicals and hard use. After repeated use, the overlay may get scratched or damaged. You can protect the touch screen from abnormal use by adding a thin film over the touch screen. When the film is worn out, simply peel it off and add a new one. The part number for screen covers for the 12.1" display is HMI-COV-205.

Agency Approvals

The chart below shows the family of *QUICKPANEL* product types, agency approvals and enclosure description.

Style	Model #	Catalog Number	Agency Approval	Enclosure
5" Mini	0880042-01	QPM-2D100-L2P	CE & UL/CUL 1950 File #171486	4X/12 Self Certified
		GP37W-LG11-24V	UL/CUL	
5" Mono	0680028-03	QPJ-2D100-L2P	UL/CUL (1)	UL 4X/12
		QPJ-2D101-L2P	CE	
		GP270-LG31-24VP	UL/CUL	IP65
		GP270-LG21-24VP	CE	
5" STN Color	0680028-04	QPJ-2D100-S2P	UL/CUL (1)	UL 4X/12
		QPJ-2D101-S2P	CE	
		GP270-SC31-24VP	UL/CUL	IP65
		GP270-SC21-24VP	CE	
6" Mono	2780051-1	QPK-2D100-L2P	UL/CUL (1), CE	UL 4X/12
		QPK-2D101-L2P	CE	
		GP370-LG41-24VP	UL/CUL (EN55022/A:1994, EN50082-2:1995)	IP65
		GP370-LG21-24VP	CE	
6" STN Color	2780051-2	QPK-2D100-S2P	UL/CUL (1), CE	UL 4X/12
		QPK-2D101-S2P	CE	
		GP370-SC41-24V	UL/CUL (EN55022/A:1994, EN50082-2:1995)	IP65
		GP370-SC21-24VP	CE	
6" TFT Color		QPK-3D200-C2P	UL/CUL, CE	
	2880037	GP377R-TC41-24VP	UL/CUL (EN55011/A2:1996, EN50082-2:1995)	
9" EL		QPI-21100-E2P	None	4X/12 Self Certified
		QPI-31200-E2P	None	
		QPI-2D100-E2P	UL/CUL (1)	UL 4X/12
		QPI-2D101-E2P	CE	
	2780027-01	QPI-3D200-E2P	UL/CUL, CE	
		GP470-EG21-24VP	CE	IP65
		GP477R-EG41-24VP	UL/CUL(EN55011/A2:1996, EN50082-2:1995)	
10.5" Mono	0880001-01	QPI-2D100-L2P	CE & UL/CUL (1)	UL 4X/12
		GP570-LG21-24V	UL/CUL (EN55022/A:1994, EN50082-2:1995)	
10.5" STN Color		QPI-21100-S2P	None	4X/12 Self Certified
		QPI-31200-S2P	None	
	0680035-04	QPI-2D100-S2P	UL/CUL (1)	UL 4X/12
		QPI-2D101-S2P	CE	
		GP570-SC31-24VP	UL/CUL	IP65
		GP570-SC21-24VP	CE	

10.5" TFT Color		QPI-21100-C2P	None	4X/12 Self Certified
		QPI-31200-C2P	None	
	2780027-02	QPI-2D100-C2P	UL/CUL (1)	UL 4X/12
		QPI-3D200-C2P	UL/CUL, CE	
		GP570-TC21-24VP	CE	IP65
		GP577R-TC41-24VP	UL/CUL (EN55011/A2:1996, EN50082-2:1995)	
10.5" TFT Color Video		QPI-211V0-C2P	None	4X/12 Self Certified
12.1" TFT Color		QPL-21100-C2P	None	4X/12 Self Certified
	2780025-01	QPL-2D200-C2P	UL/CUL, CE	
		GP675-TC41-24VP	UL/CUL (EN55022/A:1994, EN50082-2:1995)	
Hand-held Mono	0980011-01	QPH-2D100-L2P	UL/CUL	1
		GPH70-LG41-24VP	UL/CUL	
Hand-held STN Color	0980011-02	QPH-2D100-S2P	UL/CUL	1
		GPH70-SC41-24VP	UL/CUL	
AB DH+ Modules		QPX-ABD-201	CE & UL/CUL (1)	1
AB RIO Modules		QPX-ABR-201	CE & UL/CUL (1)	1
GE Genius Modules		QPX-GEG-201	UL/CUL (1)	1
Modicon Modbus+		QPX-MBP-201	UL/CUL (1)	1
Profibus		QPX-PBS-201/202	Investigating approvals	1
CANopen		QPX-COS-201	Investigating approvals	
DeviceNet		QPX-DVN-202	Investigating approvals	1
Interbus-S		QPX-IBS-201	Investigating approvals	1

(1) UL/CUL 1604 CL 1, DV 2 File #E177256

UL/CUL 1950 Listing - refers to Electrical Safety of information equipment

UL/CUL 1604 Listing - refers to Electrical Equipment that meets the Underwriter Laboratory's 1604 requirements for Class 1, Group A, B, C, and D, Division II installations and are clearly marked with a label stating "Listed Industrial Control Equipment For Hazardous Locations". UL 1604 supersedes UL1950.

QUICKPANELs will have both UL and CUL listing. CUL listed products have been tested with standards that meet the Standard Council of Canada requirements. Both Underwriters Laboratories (UL) and CSA have been accredited by the Standard Council of Canada. Therefore CUL listing is equivalent to the CSA marking.

Class 1 Division II Group A, B, C, D environment refers to a location in which flammable gas may be present. During normal operation these gases are not present. If an accident occurs allowing gas leakage, products listed for Class 1 Division 2 operation can continue to operate without danger of igniting the flammable gas while the situation that created the leak is repaired. These products are clearly marked for operation in this type of environment. The table below shows the Group letter and defines the type of gas that is in each group.

Group	Material
A	Acetylene
B	Hydrogen
C	Ethylene, Methyl Ether, Acetaldehyde
D	Acetone, Gasoline, Methanol, Propane

CE - The European Union has created standards for key product sectors to eliminate differing national requirements. The CE mark (an abbreviation for the “Conformite European” allows products to flow freely across those countries of the European Union.

These Quick Panels meet EN50082-2:1995 and EN55022 Class A (1994) requirements CE mark is needed on goods including, control equipment entering a majority of the European Countries. As of January 1, 1996 all control equipment needed to conform to the EMC directive 89/336/EEC and amended 92/31/EEC that included EN 50082-2:1995 and EN55022 Class A (1994) requirements.

Specifications

12.1" Color TFT QPL-21100-C2P

Voltage	85 to 132 VAC 50/60Hz	
Power consumption	50 VA max.	
Power failure immunity	20 ms max.	
Withstand Voltage	1500 VAC (10ma max., 1 min)	
Insulation	10 M Ω @ 500 VDC	
Noise immunity	1200 V(p-p) 1 μ s pulse	
Ratings	Suitable for IP65F, NEMA #250, Type 4X/12 (Self Certified)	
Operating temperature	0 to 40°C	
Storage temperature	-10 to 60°C	
Operating humidity	30 to 85% RH non-condensing	
Vibration	10 to 25 Hz 2G on each of X, Y, Z 30 min.	
Dimensions	10.70"H x 13.62"W x 3.19"D 272mmH, 346mmW, 81mmD	
Weight	8.4 lbs. (3.8 kg) (+ option module)	
Cooling	Natural convection	
Installation	Front Mount	
Display type	QPL-21100-C2P TFT COLOR	
Pixel resolution	800 W x 600 H	
Colors	64 (RGB – 4 Levels)	
Viewing area	9.69" W x 7.26" H (246mm x 184.5mm)	
Touch panel type	Resistive	
Touch panel resolution	40 W x 30 H	
Printer port	Yes (Serial/Parallel)	
Memory	2 Mb	
Alarms Supported	768 (3 256-alarm files)	
	QPL-2D200-C2P	
Voltage	20.4-27.6 VDC	GP675-TC41-24VP

	9" EL QPI-21100-E2P QPI-31200-E2P	10.5" Color STN/TFT QPI-21100-S2P/C2P QPI-31200-S2P/C2P
Voltage	85 to 132 VAC 50/60Hz	85 to 132 VAC 50/60Hz
Power consumption	50 VA max.	50 VA max.
Power failure immunity	20 ms max.	20 ms max.
Withstand Voltage	1500 VAC (20ma max., 1 min)	1500 VAC (20ma max., 1 min)
Insulation	10 MΩ @ 500 VDC	10 MΩ @ 500 VDC
Noise immunity	1200 V(p-p) 1 μs pulse	1200 V(p-p) 1 μs pulse
Ratings	Suitable for IP65F, NEMA #250, Type 4X/12 (Self Certified)	Suitable for IP65F, NEMA #250, Type 4X/12 (Self Certified)
Operating temperature	0 to 50°C	0 to 45°C
Storage temperature	-10 to 60°C	-10 to 60°C
Operating humidity	20 to 85% RH non-condensing	30 to 85% RH non-condensing
Storage humidity	5 to 85% RH non-condensing	5 to 85% RH non-condensing
Vibration	10 to 25 Hz 2G on each of X, Y, Z 30 min.	10 to 25 Hz 2G on each of X, Y, Z 30 min.
Dimensions	8.50"H x 10.79"W x 1.93"D 216mmH, 274mmW, 56.5mmD	9.57"H x 12.48"W x 3.05"D 243mmH, 317mmW, 85mmD
Weight	4.4 lbs. (2 kg) (+ option module)	6.6 lbs. (3 kg) (+ option module)
Cooling	Natural convection	Natural convection
Installation	Front Mount	Front Mount
Display type	Electroluminescent	QPIXXXXXS2P = STN QPIXXXXXC2P = TFT
Pixel resolution	640 W x 400 H	640 W x 480 H
Colors	Amber + flash (amber)	8 solid + 8 flash
Viewing area	7.68" W x 4.8" H, 9" diag. (192mm x 120mm)	8.48" W x 6.32" H, 10.5" diag. (212mm x 158mm)
Touch panel type	Resistive	Resistive
Touch panel resolution	32 W x 20 H	32 W x 24 H
Printer port	Yes (Serial/Parallel)	Yes (Serial/Parallel)
Memory	1Mb (QPI-2), 2Mb (QPI-3)	1Mb (QPI-2), 2Mb (QPI-3)
Alarms Supported	768 (3 256-alarm files)	768 (3 256-alarm files)
	QPI-2D100-E2P QPI-3D200-E2P	QPI-2D100-S2P/C2P QPI-3D200-S2P/C2P
Voltage	20.4-27.6 VDC	20.4-27.6 VDC
Power Consumption	50 Watts max.	50 Watts max.
Ratings	NEMA Type 4X/12, IP65	NEMA Type 4X/12, IP65
	GP470-EG21-24VP	GP570-SC21-24VP GP570-TC21-24VP
Voltage	20.4-27.6 VDC	20.4-27.6 VDC
Power Consumption	50 Watts max.	50 Watts max.
Ratings	NEMA Type 4X/12, IP65	NEMA Type 4X/12, IP65
Approvals	CE Marked. EN50082-2:1995 EN55022 Class A (94)	CE Marked. EN50082-2:1995 EN55022 Class A (94)

10.5" Monochrome LCD
QPI-2D100-L2P, QPI-2D200-L2P

Voltage	20.4-27.6 VDC
Power consumption	50 Watts max.
Power failure immunity	20 ms max.
Withstand Voltage	1500 VAC (20ma max., 1 min)
Insulation	10 M Ω @ 500 VDC
Noise immunity	1200 V(p-p) 1 μ s pulse
Ratings	Suitable for IP65F, NEMA #250, Type 4X/12
Operating temperature	0 to 45°C
Storage temperature	-10 to 60°C
Operating humidity	30 to 85% RH non-condensing
Storage humidity	5 to 85% RH non-condensing
Vibration	10 to 25 Hz 2G on each of X, Y, Z 30 min.
Dimensions	9.57"H x 12.48"W x 3.05"D 243mmH, 317mmW, 85mmD
Weight	6.6 lbs. (3 kg) (+ option module)
Cooling	Natural convection
Installation	Front Mount
Display type	LCD Monochrome
Pixel resolution	640 W x 480 H
Colors	White/Black + Flash
Viewing area	8.48" W x 6.32" H, 10.5" diag. (212mm x 158mm)
Touch panel type	Resistive
Touch panel resolution	32 W x 24 H
Printer port	Yes (Serial/Parallel)
Memory	1 Mb
Alarms Supported	768 (3 256-alarm files)

6" Color TFT
OPK-3D200-C2P

Voltage	20.4-27.6 VDC
Power consumption	20 Watts or less (Typ: 13W)
Power failure immunity	2 ms or less
Withstand Voltage	1000 VAC (10ma max., 1 min)
Insulation	10 M Ω @ 500 VDC
Noise immunity	1000 V(p-p) 1 μ s pulse
Ratings	Suitable for IP65F
Operating temperature	0 to 40°C
Storage temperature	-10 to 60°C
Operating humidity	20 to 85% RH non-condensing
Storage humidity	5 to 85% RH non-condensing
Operating Atmosphere	Must be free of corrosive gasses
Grounding	100 Ohm or less grounding resistance
Dust	Under 0.1 mg/m ³ (Non-conductive levels)
Dimensions	6.71" (W) x 5.43" (H) x 2.24" (D) 170.5mm (W) x 138mm (H) x 57mm (D)
Weight	2.08 lbs. (950g or less) (Main unit only)
Cooling	Natural convection
Installation	Front Mount
Display type	TFT Color LCD
Pixel resolution	320 x 240 pixels
Colors	64 colors (RGB-4 levels)
Brightness	4 levels (via touch panel)
Backlight	CCFL (lifespan = more than 50,000 hours, when continuously lit)
Viewing area	4.53" (W) x 3.40" (H) 115.2mm (W) x 86.4mm (H)
Touch panel type	Resistive
Touch panel resolution	16 W x 12 H
Printer port	Yes (Serial)
Memory	2 Mb
Alarms Supported	768 (3 256-alarm files)

	6" LCD Monochrome OPK-2D100-L2P	6" STN Color OPK-2D100-S2P
Voltage	20.4-27.6 VDC	20.4-27.6 VDC
Power consumption	12 Watts max.	15 Watts max.
Power failure immunity	20 ms max.	20 ms max.
Withstand Voltage	1500 VAC (10ma max., 1 min)	1500 VAC (10ma max., 1 min)
Insulation	10 MΩ @ 500 VDC	10 MΩ @ 500 VDC
Noise immunity	1000 V(p-p) 1 μs pulse	1000 V(p-p) 1 μs pulse
NEMA rating	4X/12	4X/12
Operating temperature	0 to 50°C	0 to 45°C
Storage temperature	-20 to 60°C	-20 to 60°C
Operating humidity	20 to 85% RH non-condensing	20 to 85% RH non-condensing
Storage humidity	5 to 85% RH non-condensing	5 to 85% RH non-condensing
Vibration	10 to 25 Hz 2G on each of X, Y, Z 30 min.	10 to 25 Hz 2G on each of X, Y, Z 30 min.
Dimensions	5.43"H x 6.71"W x 2.24"D 138mmH, 170.5mmW, 57mmD	5.43"H x 6.71"W x 2.24"D 138mmH, 170.5mmW, 57mmD
Weight	1.54 lbs. (<700g)	1.54 lbs. (<700g)
Cooling	Natural convection	Natural convection
Installation	Front Mount	Front Mount
Display type	LCD	Passive STN LCD
Pixel resolution	240 H x 320 W	240 H x 320 W
Colors	White/Black + flash	8 solid + 8 flash
Viewing area	4.53" (W) x 3.40" (H) 115.2mm (W) x 86.4mm (H)	4.53" (W) x 3.40" (H) 115.2mm (W) x 86.4mm (H)
Touch panel type	Resistive	Resistive
Touch panel resolution	15 W x 11 H	15 W x 11 H
Printer Port	Yes (Serial)	Yes (Serial)
Memory	1 Mb	1 Mb
Alarms Supported	512 (2 256-alarm files)	512 (2 256-alarm files)

**6" Mini LCD Monochrome
QPM-2D100-L2P**

Voltage	20.4-27.6 VDC
Power consumption	12 Watts max.
Ratings	NEMA 12/4 self-certified, CE and UL 1950 Approved
Operating temperature	0 to 50°C
Storage temperature	-20 to 60°C
Operating humidity	30 to 85% RH non-condensing
Storage humidity	5 to 85% RH non-condensing
Dimensions	6.299"H x 8.267"W x 2.28"D 160mmH, 210mmW, 58mmD
Weight	1.65 lbs. (<700g)
Cooling	Natural convection
Installation	Front Mount
Display type	LCD
Pixel resolution	240 H x 320 W
Colors	White/Black + flash
Viewing area	5" W x 4" H, 6" diagonal
Touch panel type	Resistive
Touch panel resolution	15 W x 11 H
Printer Port	Yes (Serial)
Memory	5 Panels
Alarms Supported	None

	5" LCD Monochrome QPJ-2D100-L2P	5" STN Color QPJ-2D100-S2P
Voltage	20.4-27.6 VDC	20.4-27.6 VDC
Power consumption	12 Watts max.	15 Watts max.
Power failure immunity	20 ms max.	20 ms max.
Withstand Voltage	1500 VAC (10ma max., 1 min)	1500 VAC (10ma max., 1 min)
Insulation	10 MΩ @ 500 VDC	10 MΩ @ 500 VDC
Noise immunity	1000 V(p-p) 1 μs pulse	1000 V(p-p) 1 μs pulse
NEMA rating	4X/12	4X/12
Operating temperature	0 to 50°C	0 to 45°C
Storage temperature	-20 to 60°C	-20 to 60°C
Operating humidity	20 to 85% RH non-condensing	20 to 85% RH non-condensing
Storage humidity	5 to 85% RH non-condensing	5 to 85% RH non-condensing
Vibration	10 to 25 Hz 2G on each of X, Y, Z 30 min.	10 to 25 Hz 2G on each of X, Y, Z 30 min.
Dimensions	5.00"H x 6.75"W x 2.125"D 127mmH, 172mmW, 54mmD	5.00"H x 6.75"W x 2.125"D 127mmH, 172mmW, 54mmD
Weight	1.54 lbs. (<700g)	1.54 lbs. (<700g)
Cooling	Natural convection	Natural convection
Installation	Front Mount	Front Mount
Display type	LCD	Passive STN LCD
Pixel resolution	240 H x 320 W	240 H x 320 W
Colors	White/Black + flash	8 solid + 8 flash
Viewing area	4" W x 3" H, 5" diagonal	4" W x 3" H, 5" diagonal
Touch panel type	Resistive	Resistive
Touch panel resolution	15 W x 11 H	15 W x 11 H
Printer Port	Yes (Serial)	Yes (Serial)
Memory	256K	256K
Alarms Supported	512 (2 256-alarm files)	512 (2 256-alarm files)
	GP270-LG21-24VP	GP270-SC21-24VP
Voltage	20.4-27.6 VDC	20.4-27.6 VDC
Power Consumption	12 Watts max.	12 Watts max.
Ratings	NEMA Type 4X/12, IP65	NEMA Type 4X/12, IP65
Approvals	CE Marked. EN50082-2:1995 EN55022 Class A (94)	CE Marked. EN50082-2:1995 EN55022 Class A (94)

QPH Specifications

QPH-xxxxx-xxx

Voltage	20.4-27.6 VDC, 12W max (typ 10W)
Power consumption	15 Watts max.
Power failure immunity	20 ms max.
Withstand Voltage	1500 VAC (10ma max., 1 min)
Insulation	10 M Ω @ 500 VDC
Noise immunity	1000 V(p-p) 1 μ s pulse
NEMA rating	4X/12
Operating temperature	0 to 40°C
Storage temperature	-20 to 60°C
Operating humidity	20 to 85% RH non-condensing
Vibration	10 to 25 Hz 2G on each of X, Y, Z 30 min.
Dimensions	6.81"H x 9.33"W x 2.68"D 173mmH, 237mmW, 68mmD
Weight	1.9 lbs. (870g)
Cooling	Natural convection
Rating	IP63, NEMA1
Installation	Front Mount
Display type	Passive STN LCD Color
Pixel resolution	240 H x 320 W
Colors	8 solid + 8 flash
Viewing area	5" W x 4" H, 6.4" diagonal
Touch panel type	Analog Resistive
Touch panel resolution	115 W x 86 H
Printer Port	Yes (Serial)
Alarms Supported	512 (2 256-alarm files)

QPV Specifications
QPV-2100-C2P

Voltage	85 to 132 VAC 50/60Hz
Power consumption	50 VA max.
Power failure immunity	20 ms max.
Withstand Voltage	1500 VAC (20ma max., 1 min)
Insulation	10 M Ω @ 500 VDC
Noise immunity	1200 V(p-p) 1 μ s pulse
Ratings	Suitable for IP65F, NEMA #250, Type 4X/12 (Self Certified)
Operating temperature	0 to 45°C
Storage temperature	-10 to 60°C
Operating humidity	30 to 85% RH non-condensing
Vibration	10 to 25 Hz 2G on each of X, Y, Z 30 min.
Dimensions	9.57"H x 12.48"W x 3.05"D 243mmH, 317mmW, 85mmD
Weight	6.6 lbs. (3 kg) (+ option module)
Cooling	Natural convection
Installation	Front Mount
Display type	10.5" Color TFT
Pixel resolution	640 W x 480 H
Colors	8 solid + 8 flash
Viewing area	8.48" W x 6.32" H, 10.5" diag. (212mm x 158mm)
Touch panel type	Analog Resistive
Touch panel resolution	32 W x 24 H
Printer port	Yes (Serial/Parallel)
Memory	1Mb
Video Inputs	3 NTSC BNC

Exposed Material Chemical Resistance Chart

The following charts list the materials used in the construction of TCP products and rates their resistance or susceptibility to chemicals commonly encountered in industry. The information contained in the charts is based upon data supplied by the manufacturers of the various materials and is believed to be accurate. The temperature, concentration or combination with other chemicals can affect the way a particular chemical reacts with a given material. Thus, the charts contained herein should only be used as a general guide and not as an unqualified authority. All of the material resistance's or susceptibilities listed assume normal equipment operating temperatures. Additionally, one must be aware that if a protective coating on a particular material is damaged, the substrate may be adversely affected by an otherwise non-reactive chemical.

An Acceptable Resistance rating means that the chemical may remain in contact with the exposed material indefinitely with no appreciable degradation of the exposed material.

A Marginal Resistance rating means that the chemical will not cause any appreciable degradation of the exposed material on an intermittent basis or that only minor degradation will occur that will not impair the performance of the material.

An Unacceptable Resistance rating means that the chemical will degrade the performance of the exposed material to such a degree that the material no longer performs as designed.

A Not Tested rating simply means that the exposed material has not been tested for resistance to a particular chemical.

QUICK PANEL, QUICK PANEL JR.

304 STAINLESS STEEL - 4X only
GASKET QPJ
POLYESTER OVERLAY
QP PLASTIC HOUSING
RTV SEALING COMPOUND

GASKET B41NES
GASKET HMI
QP 4X MEMBRANE - 4X only
QP TOUCH SCREEN

KEY: A = Acceptable Resistance M = Moderate Resistance U = Unacceptable Resistance T = Not Tested	304 STAINLESS STEEL	SILICONE RUBBER	GASKET B41NES	GASKET HMI	GASKET QPJ	KEYPADS	LEXAN LENS	O-RINGS	POLANE PAINT	POLYESTER COATED PARTS	POLYESTER OVERLAYS	RTV SEALING COMPOUND	QP, ST 4X MEMBRANE	QP, ST PLASTIC HOUSING	QP, ST TOUCH SCREEN
1,1,1 trichlorethane	A	C	T	C	C	T	T	T	T	T	T	T	C	T	T
acetaldehyde	A	M	T	U	M	A	T	M	T	T	A	T	U	U	T
acid, 10% acetic	T	T	A	U	T	M	A	U	T	A	M	T	T	M	M
acid, 10% hydrochloric	U	T	A	U	A	A	A	U	T	A	A	T	A	A	M
acid, 10% nitric	A	T	A	U	M	M	A	U	T	A	M	T	A	M	M
acid, 10% sulfuric	U	T	A	U	U	T	A	U	T	A	T	T	A	M	M
acid, concentrated acetic	T	T	A	U	M	U	M	U	T	A	U	T	T	T	U
acid, concentrated hydrochloric	U	T	A	U	T	U	M	U	T	A	U	T	A	T	U
acid, concentrated sulfuric	U	T	A	U	U	U	M	U	T	A	U	T	A	T	U
acid, potassium	T	T	A	U	T	T	T	T	T	A	T	T	T	T	T
alcohol, benzyl	A	T	T	M	M	T	A	U	T	A	T	T	T	T	T
aliphatic hydrocarbons	T	T	A	T	T	A	A	T	T	A	A	T	A	T	T
amines	A	M	T	M	M	T	U	U	T	T	T	T	M	T	T
ammonia, 10%	T	A	T	A	T	U	T	U	T	M	U	T	M	T	M
ammonia, concentrated	M	T	T	A	T	U	T	U	T	M	U	T	M	T	U
ammonium hydroxide	A	M	A	A	A	T	T	M	T	T	T	T	A	M	T
aromatic hydrocarbons	T	T	M	U	U	T	U	T	T	T	T	T	U	T	T
benzene	A	T	M	U	U	A	T	U	A	A	A	T	A	U	A
brake fluid	A	M	T	T	T	T	T	A	A	T	T	A	T	U	T
carbon tetrachloride	M	U	T	U	T	T	T	M	A	M	T	T	T	U	T
chloroform	A	T	T	U	U	T	T	U	T	T	T	T	U	U	M
diethyl ether	T	M	T	T	T	A	T	T	T	T	A	T	T	T	T
esters	T	T	T	T	T	T	U	T	T	U	T	T	U	T	T
ethylene chloride	A	U	T	U	U	T	T	U	T	M	T	T	U	U	T
gasoline	A	U	A	U	U	T	U	A	A	A	T	T	U	U	T
halogenated hydrocarbons	T	T	T	T	T	T	U	T	T	A	T	T	T	T	T
jet fuel	A	U	A	U	U	T	U	A	A	A	T	T	M	T	T
kerosene	A	U	A	U	A	T	U	A	A	A	T	T	A	T	T
lacquer thinner	T	T	T	U	A	T	U	U	A	T	T	T	T	T	U
methanol	A	T	T	A	A	A	A	M	A	A	A	T	T	U	T

	304 STAINLESS STEEL	SILICONE RUBBER	GASKET B41NES	GASKET HMI	GASKET QPJ	KEYPADS	LEXAN LENS	O-RINGS	POLANE PAINT	POLYESTER COATED PARTS	POLYESTER OVERLAYS	RTV SEALING COMPOUND	QP, ST 4X MEMBRANE	QP, ST PLASTIC HOUSING	QP, ST TOUCH SCREEN
KEY: A = Acceptable Resistance M = Moderate Resistance U = Unacceptable Resistance T = Not Tested															
nitric acid ethyl	T	T	A	T	T	T	T	T	T	A	T	T	T	T	M
ozone	T	A	A	T	T	T	T	T	T	T	T	T	T	T	T
perchlorethylene	T	U	T	U	U	T	T	T	T	T	T	T	T	T	T
petrol	A	T	A	T	T	A	T	A	A	A	A	T	U	T	T
phenol	A	T	T	U	U	T	T	U	T	T	T	T	A	U	T
toluene	A	U	T	U	U	A	U	U	T	T	A	T	U	U	A
trichlorethylene	A	U	T	U	U	A	U	U	T	T	A	T	U	T	T
turpentine	A	A	M	U	U	A	U	U	A	T	A	T	U	U	T
xylol	T	T	T	T	T	T	T	T	A	T	T	T	T	T	T
acetone	A	M	T	U	A	A	U	U	A	A	A	T	U	U	A
alcohol, ethyl	A	M	T	A	M	A	A	A	T	A	A	T	A	U	T
alcohol, isopropyl	A	M	T	M	A	A	A	U	T	A	A	T	T	U	T
alkalis	T	U	A	T	T	M	M	T	T	U	M	T	T	M	U
butyl cellosolve	T	T	T	T	T	T	U	T	T	T	T	T	T	T	T
caustic soda, 10%	A	M	A	M	A	U	A	A	T	U	U	T	T	A	U
caustic soda, 40%	A	U	A	T	T	U	M	U	T	U	U	T	T	T	U
chlorinated solvents	T	T	U	T	T	T	T	T	T	M	T	T	U	T	T
coolants	A	A	A	A	T	A	A	A	A	A	A	A	A	A	T
cyclohexane	T	U	T	U	U	A	T	A	T	T	A	T	U	U	T
detergents	A	A	A	M	A	A	A	A	A	A	A	A	M	M	A
ethanol	A	M	T	A	A	A	A	A	A	A	A	T	A	U	A
ethyl acetate	A	M	T	U	M	A	T	U	T	T	A	T	U	U	T
fruit juices	A	A	A	A	T	A	A	A	A	A	A	T	A	A	A
greases	A	T	A	U	T	A	M	A	A	A	A	A	M	M	A
glycol antifreeze	A	A	A	T	A	A	T	A	A	A	A	A	A	T	T
hexane	A	M	T	M	U	T	T	A	T	T	T	T	T	A	T
methyl chloride	M	U	T	U	U	T	T	U	T	M	T	T	M	U	T
methyl ethyl ketone	A	M	T	U	A	A	U	U	A	M	A	T	U	U	T
methylene chloride	A	T	T	U	U	T	T	U	T	M	T	T	U	T	T
oil, animal	A	A	A	U	A	A	A	A	A	A	A	A	A	M	A

	304 STAINLESS STEEL	SILICONE RUBBER	GASKET B41NES	GASKET HMI	GASKET QPJ	KEYPADS	LEXAN LENS	O-RINGS	POLANE PAINT	POLYESTER COATED PARTS	POLYESTER OVERLAYS	RTV SEALING COMPOUND	QP, ST 4X MEMBRANE	QP, ST PLASTIC HOUSING	QP, ST TOUCH SCREEN
KEY:															
A = Acceptable Resistance															
M = Moderate Resistance															
U = Unacceptable Resistance															
T = Not Tested															
oil, cutting	A	A	A	U	T	A	A	A	A	A	A	A	A	U	A
oil, diesel	A	T	A	U	U	A	A	A	A	A	A	A	A	T	A
oil, hydraulic	A	T	A	T	T	A	A	A	A	A	A	A	A	T	A
oil, lube	A	M	A	T	T	A	A	A	A	A	A	A	A	M	A
oil, motor	A	M	A	T	T	A	A	A	A	A	A	A	A	M	A
oil, petroleum	A	M	A	T	T	A	A	A	A	A	A	A	A	M	A
oil, silicone	A	A	A	A	T	A	A	A	A	A	A	A	A	M	A
oil, vegetable	A	A	A	U	U	A	A	A	A	A	A	A	A	M	A
salt spray , 5%	A	A	A	A	A	A	A	A	A	A	A	T	A	A	A
soap solution	A	A	A	A	A	A	A	A	A	A	A	T	A	M	A
water	A	A	A	A	A	A	A	A	A	A	A	A	A	A	A
xylene	A	U	T	U	U	A	T	U	T	T	A	T	U	U	T

Product Enclosure Ratings

The following table lists the various TCP operator interface products and their associated enclosure type ratings. Please note that a product listed as ‘DESIGNED to enclosure type rating’ means that the enclosure was designed to meet the requirements of a specified enclosure rating but never was formally tested by an independent party to certify its rating. A product listed as ‘TESTED to enclosure type rating’ means that an independent party has certified the enclosure rating. The enclosure ratings for any given product are only valid when correctly mounted in an appropriate control panel.

TYPE 1:

For indoor use primarily to provide a degree of protection against limited amounts of falling dirt.

TYPE 4:

For indoor or outdoor use primarily to provide a degree of protection against windblown dust and rain, splashing water, hose-directed water, and damage from external ice formation.

TYPE 4X:

For indoor or outdoor use primarily to provide a degree of protection against corrosion, windblown dust and rain, splashing water, hose-directed water, and damage from external ice formation. Indoor use only may be stipulated.

TYPE 12:

For indoor use primarily to provide a degree of protection against circulating dust, falling debris, and dripping noncorrosive liquids.

TYPE 13:

For indoor use primarily to provide a degree of protection against dust, spraying of water, oil and noncorrosive liquids.

KEY:

D = DESIGNED to enclosure type rating

T = TESTED to enclosure type rating

	TYP E 1	TYP E 4	TYPE 4X INDOOR ONLY	TYPE 12	TYPE 13
QUICK PANEL	D	D	D note 1	D	D
QUICK PANEL JR.	D	D	D note 1	D	D

note 1: only when equipped with optional stainless steel bezel and 4X membrane