

**GFK-1866**  
**New In Stock!**  
**GE Fanuc Manuals**

<http://www.pdfsupply.com/automation/ge-fanuc-manuals/motion-solutions/GFK-1866>

**motion-solutions**

**1-919-535-3180**

S2K Series Brushless Servo Amplifier

[www.pdfsupply.com](http://www.pdfsupply.com)

**Email:** [sales@pdfsupply.com](mailto:sales@pdfsupply.com)

**GFK-1866**  
**New In Stock!**  
**~~GE Fanuc~~ Manuals**

<http://www.pdfsupply.com/automation/ge-fanuc-manuals/motion-solutions/GFK-1866>

**motion-solutions**

**1-919-535-3180**

S2K Series Brushless Servo Amplifier

[www.pdfsupply.com](http://www.pdfsupply.com)

**Email:** [sales@pdfsupply.com](mailto:sales@pdfsupply.com)



# ***GE Fanuc Automation***

---

***Programmable Control Products***

***S2K Series  
Brushless Servo Amplifier***

***User's Manual***

GFK-1866A

September 2002

## *Warnings, Cautions, and Notes as Used in this Publication*

### **Warning**

**Warning notices are used in this publication to emphasize that hazardous voltages, currents, temperatures, or other conditions that could cause personal injury exist in this equipment or may be associated with its use.**

**In situations where inattention could cause either personal injury or damage to equipment, a Warning notice is used.**

### **Caution**

**Caution notices are used where equipment might be damaged if care is not taken.**

### **Note**

Notes merely call attention to information that is especially significant to understanding and operating the equipment.

This document is based on information available at the time of its publication. While efforts have been made to be accurate, the information contained herein does not purport to cover all details or variations in hardware or software, nor to provide for every possible contingency in connection with installation, operation, or maintenance. Features may be described herein which are not present in all hardware and software systems. GE Fanuc Automation assumes no obligation of notice to holders of this document with respect to changes subsequently made.

GE Fanuc Automation makes no representation or warranty, expressed, implied, or statutory with respect to, and assumes no responsibility for the accuracy, completeness, sufficiency, or usefulness of the information contained herein. No warranties of merchantability or fitness for purpose shall apply.

The following are trademarks of GE Fanuc Automation North America, Inc.

Alarm Master	Genius	PowerMotion	VersaMax
CIMPLICITY	Helpmate	PowerTRAC	VersaPro
CIMPLICITY 90-ADS	Logicmaster	Series 90	VuMaster
CIMSTAR	Modelmaster	Series Five	Workmaster
Field Control	Motion Mate	Series One	
FrameworkX	ProLoop	Series Six	
GEnet	PROMACRO	Series Three	

## Content of This Manual

- Chapter 1. Before Operation:** Unpacking and inspecting components, storage, and product part number reference.
- Chapter 2. Hardware Overview:** Product specifications, motor speed/torque curves.
- Chapter 3. Installation:** Heat load ratings, mounting and wiring.
- Chapter 4. Getting Started:** Connecting the system, establishing communications with the amplifier, configuring the system.
- Chapter 5. Software Reference:** Command and register listing.
- Chapter 6. Diagnostics:** Status codes, command messages, and diagnostics.
- Appendix A. Tables and Formulas:** ASCII codes, temperature conversion, wire size conversion, English to metric conversion.
- Appendix B. Installing and Registering Motion Developer:** How to install the software on your PC and register it with GE Fanuc.
- Appendix C. Interfacing with GE Fanuc APM or DSM Series Motion Controllers:** How to connect the S2K amplifier to work with a GE Fanuc APM or DSM series motion controller.

## Related Publications

GFK-1464, *Motion Mate™ DSM302 for Series 90™-30 PLCs User's Manual*

GFK-1742, *Motion Mate™ DSM314 for Series 90™-30 PLCs User's Manual*

GFK-0840, *Power Mate™ APM for Series 90™-30 PLC Standard Mode User's Manual*

GFK-0781, *Power Mate™ APM for Series 90™-30 PLC Follower Mode User's Manual*

---

<sup>™</sup> Motion Mate and Series 90 are trademarks of GE Fanuc, Power Mate is a trademark of Fanuc



<b>Chapter 1</b>	<b>Before Operation .....</b>	<b>1-1</b>
1.1	System Overview .....	1-1
1.2	Unpacking Components .....	1-2
1.3	Storage.....	1-2
1.4	Part Numbers.....	1-2
1.4.1	Cable and Connector Part Numbers.....	1-2
1.4.2	Motor Part Numbers .....	1-3
1.4.3	S2K Series Brushless Servo Amplifier Part Numbers .....	1-4
1.4.4	Accessory Part Numbers.....	1-4
1.4.4.1	Regeneration Resistors.....	1-4
1.4.4.2	Terminal Block Assemblies .....	1-4
1.5	Confirming System Components .....	1-5
1.6	Agency Approvals.....	1-7
 <b>Chapter 2</b>	 <b>Hardware Overview .....</b>	 <b>2-1</b>
2.1	Specifications .....	2-1
2.1.1	Electrical Specifications.....	2-1
2.1.2	Isolation Transformer.....	2-2
2.1.3	Environmental Specifications .....	2-2
2.1.4	Communication Specifications .....	2-3
2.1.5	Input And Output Specifications .....	2-3
2.1.6	Encoder Input And Output Specifications .....	2-4
2.1.7	Servo Motor Specifications.....	2-5
2.2	Motor Speed/Torque Curves .....	2-12
2.2.1	S-Series Servo Motor / Controller Curves .....	2-12
2.3	S-Series Motor Derating Based on Ambient Temperature.....	2-15
2.4	Servo Motor Sealing.....	2-16
2.5	Servo Motor Holding Brakes .....	2-16
2.6	Motor Mounting .....	2-17
 <b>Chapter 3</b>	 <b>Installation .....</b>	 <b>3-1</b>
3.1	Heat Load and Cooling.....	3-1
3.2	Amplifier Mounting Guidelines and Environmental Conditions .....	3-1
3.3	Installing the Amplifier .....	3-2
3.4	Installing the Motor .....	3-3
3.5	Mounting Dimensions .....	3-4
3.5.1	Amplifier Dimensions.....	3-4
3.5.2	S-Series Servo Motor Dimensions.....	3-6
3.5.3	MTR-3T Series Servo Motor Dimensions .....	3-12
3.6	Wiring.....	3-22
3.6.1	General Wiring Considerations.....	3-22
3.6.2	AC Supply and Motor Wiring and Grounding.....	3-22

3.6.3	S-Series Servo Motor Encoder Wiring .....	3-25
3.6.4	S-Series Servo Motor Power and Brake Wiring and Grounding .....	3-26
3.6.5	MTR-Series Servo Motor Power and Brake Wiring and Grounding....	3-27
3.6.6	MTR-Series Servo Motor Resolver Wiring.....	3-28
3.6.7	Serial Communications Wiring.....	3-30
3.6.8	Auxiliary I/O Wiring.....	3-30
3.6.9	Connection Diagrams.....	3-37
3.6.10	Cables and Connector Mates .....	3-45
3.7	Wiring The Optional Motor Brake .....	3-47
3.8	Regenerative Discharge Resistor Selection and Wiring.....	3-48
3.8.1	Calculating Regenerative Power and Selecting a Resistor .....	3-51
3.9	Dynamic Braking Contact and Operation .....	3-55
<b>Chapter 4</b>	<b>Getting Started.....</b>	<b>4-1</b>
4.1	Establishing Communications .....	4-1
4.1.1	Connect The Serial Cable .....	4-1
4.1.2	Start The Terminal Emulation Software .....	4-1
4.1.2.1	Using Hyper Terminal .....	4-2
4.1.2.2	Using Motion Developer.....	4-6
	Software Introduction.....	4-6
	Setting up the Motion Developer Screen.....	4-7
	Creating a New Project .....	4-8
	Turning the Motion Toolbar ON or OFF .....	4-10
4.2	Configuring The Operating Mode .....	4-13
4.2.1	Torque Mode Operation.....	4-13
4.2.1.1	Example of Scaling The Torque Command Input .....	4-14
4.2.2	Velocity Mode Operation .....	4-15
4.2.2.1	Example of Scaling The Velocity Command Input .....	4-16
4.2.3	Position Mode Operation .....	4-16
4.2.3.1	Examples of Scaling The Pulse Command Input.....	4-17
4.2.3.2	Configuring The Encoder Output .....	4-18
4.3	Setting The Torque Limit .....	4-20
4.4	Setting Motor Direction.....	4-20
4.5	Enable Input .....	4-20
4.6	Configuration Parameters .....	4-21
4.7	Tuning .....	4-23
4.7.1	Using Autotuning.....	4-23
4.7.2	Manually Setting the Tuning Parameters.....	4-24
<b>Chapter 5</b>	<b>Software Reference.....</b>	<b>5-1</b>
5.1	Software Overview .....	5-1
5.2	Alphabetical Command and Register Guide .....	5-2
5.3	Commands and Registers .....	5-3

<b>Chapter 6</b>	<b>Diagnostics .....</b>	<b>6-1</b>
6.1	LED Display Status Codes .....	6-1
6.2	Status Register Messages .....	6-2
6.2.1	Fault Code Register (FC) .....	6-2
6.2.2	Fault Input Register (FI) .....	6-4
6.2.3	General I/O Register (IO) .....	6-5
6.2.4	Axis Status Register (SRA) .....	6-6
6.3	Query Registers for Current Data (Q, ?) .....	6-6
6.4	Troubleshooting Flow Chart .....	6-7
 <b>Appendix A</b>	 <b>Tables and Formulas.....</b>	 <b>A-1</b>
	Standard ASCII (American Standard Code for Information Interchange) Codes .....	A-1
	AWG to Metric Wire Size Conversion .....	A-2
	Temperature Conversion.....	A-3
	Formulas.....	A-3
	Table.....	A-3
	Miscellaneous Equivalents.....	A-4
	Fraction-Decimal-Metric Equivalents.....	A-5
	English and Metric Equivalents .....	A-6
 <b>Appendix B</b>	 <b>Installing and Registering Motion Developer .....</b>	 <b>B-1</b>
B.1	Installing Motion Developer .....	B-1
B.1.1	Computer System Requirements.....	B-1
	Hardware .....	B-1
	Software .....	B-1
B.1.2	Installation .....	B-1
	To Install Motion Developer from a CD: .....	B-1
B.2	Product Authorization.....	B-2
B.2.1	To Authorize Motion Developer:.....	B-2
B.2.2	To Move the Authorization to Another Computer.....	B-2
B.3	Technical Support for Motion Developer Software.....	B-4
	Contact Choices .....	B-4
	For Most Efficient Service .....	B-4
 <b>Appendix C</b>	 <b>Interfacing With GE Fanuc APM or DSM Series Motion Controllers.....</b>	 <b>C-1</b>
C.1	Wiring the S2K Amplifier to the APM300 Motion Controller.....	C-1
C.2	Wiring the S2K Amplifier to a DSM Motion Controller.....	C-2
C.1.1	Auxiliary Terminal Board Description and Mounting Dimensions.....	C-4
C.1.2	Converting the Terminal Board From DIN-Rail to Panel Mounting.....	C-5
C.1.3	Auxiliary Terminal Block Pin Assignments .....	C-6

Figure 3-1. SSD104, SSD107 and SSD407 S2K Series Amplifier Dimensions and Weight.....	3-4
Figure 3-2. SSD216, SSD228 and SSD420 S2K Series Amplifier Dimensions and Weight.....	3-5
Figure 3-3. Dimensions for 30-100 Watt SL Series Motors.....	3-6
Figure 3-4. Dimensions for 200 Watt S-Series Servo Motor .....	3-7
Figure 3-5. Dimensions for 400 Watt S-Series Servo Motor .....	3-8
Figure 3-6. Dimensions for 750 Watt S-Series Servo Motor .....	3-9
Figure 3-7. Dimensions for 1000 Watt and 2500 W S-Series Servo Motors .....	3-10
Figure 3-8. Dimensions for 4500 Watt and 5000 W S-Series Servo Motors .....	3-11
Figure 3-9. Dimensions for MTR-3T1x-Series Servo Motors .....	3-12
Figure 3-10. Dimensions for MTR-3T2x-Series Servo Motors .....	3-13
Figure 3-11. Dimensions for MTR-3T4x-Series Servo Motors .....	3-13
Figure 3-12. Dimensions for MTR-3T5x-Series Servo Motors .....	3-14
Figure 3-13. Dimensions for MTR-3T6x-Series Servo Motors .....	3-14
Figure 3-14. Dimensions for MTR-3N2x-Series Servo Motors.....	3-15
Figure 3-15. Dimensions for MTR-3N3x-Series Servo Motors.....	3-16
Figure 3-16. Dimensions for MTR-3S2x-Series Servo Motors.....	3-17
Figure 3-17. Dimensions for MTR-3S3x-Series Servo Motors.....	3-18
Figure 3-18. Dimensions for MTR-3S4x-Series Servo Motors.....	3-19
Figure 3-19. Dimensions for MTR-3S6x-Series Servo Motors.....	3-20
Figure 3-19. Dimensions for MTR-3S8x-Series Servo Motors.....	3-21
Figure 3-20. S-Series Servo Motor Serial Encoder Feedback Connectors.....	3-25
Figure 3-21. S-Series Motor Power Connections .....	3-27
Figure 3-22. MTR-3T Series Motor/Brake Power Connections.....	3-28
Figure 3-23. MTR-3N and MTR-3S Series Motor Power Connections.....	3-28
Figure 3-24. MTR-3N and MTR-3S Series Optional Brake Power Connections .....	3-28
Figure 3-25. MTR-Series Resolver Feedback Connections .....	3-29
Figure 3-26. Connection Diagram for the 4.3 A 115/230 VAC Serial Encoder-Based Servo Amplifier (SSD104).....	3-37
Figure 3-27. Connection Diagram for the 4.3 A 115/230 VAC Resolver-Based Servo Amplifier (SSD104R) .....	3-38
Figure 3-28. Connection Diagram for the 7.2A 115/230 VAC Serial Encoder-Based Servo Amplifier (SSD107).....	3-39
Figure 3-29. Connection Diagram for the 7.2A 115/230 VAC Resolver-Based Servo Amplifier (SSD107R).....	3-40
Figure 3-30. Connection Diagram for the 16 A & 28 A 230 VAC Serial Encoder-Based Servo Amplifiers (SSD216 & SSD228).....	3-41
Figure 3-31. Connection Diagram for the 16 A & 28 A 230 VAC Resolver-Based Servo Amplifiers (SSD216R & SSD228R) .....	3-42

Figure 3-32. Connection Diagram for the 7.2A 460 VAC Resolver-Based Servo Amplifier (SSD407R)..	3-43
Figure 3-33. Connection Diagram for the 20A 460 VAC Resolver-Based Servo Amplifier (SSD420R)...	3-44
Figure 3-34. Typical Brake Wiring Diagram.....	3-47
Figure 3-35. Regenerative Discharge Resistor Mounting and Wiring Dimensions .....	3-50
Figure 3-36. Typical External Dynamic Brake Circuit.....	3-55
Figure C-1. APM300 Terminal Block and Cable Connections .....	C-1
Figure C-2. APM300 to S2K Amplifier Connections Using Terminal Block 44A726268-001.....	C-2
Figure C-3. DSM Terminal Boards and Cables for S2K Amplifier Interface .....	C-3
Figure C-4. Auxiliary Terminal Board with Mounting Dimensions .....	C-4
Figure C-5. Auxiliary Terminal Board Assembly Drawings.....	C-5
Figure C-6. Auxiliary Terminal Board Assembly Side View .....	C-6
Figure C-7. DSM Analog Interface to SSD104, SSD107, and SSD407 Amplifier (With external Enable)	C-8
Figure C-8. DSM Analog Interface to SSD216, SSD228, and SSD420 Amplifier (With external Enable)	C-8

# Contents

---

Table 1-1. S-Series Motor/Amplifier Compatibility for Serial Encoder-based Amplifiers.....	1-5
Table 1-2. MTR-Series Motor/Amplifier Compatibility for Resolver-based Amplifiers.....	1-6
Table 2-1. Hardware Resources.....	2-1
Table 2-2. Amplifier Power Specifications .....	2-2
Table 2-3. Environmental Specifications .....	2-2
Table 2-4. Serial Communication Specifications .....	2-3
Table 2-5. Input and Output Specifications .....	2-3
Table 2-6. Encoder and Resolver Input/Output Specifications .....	2-4
Table 2-7. S-Series Motor Specifications.....	2-5
Table 2-8. MTR-3N Series Motor Specifications.....	2-7
Table 2-9. MTR-3S Series Motor Specifications .....	2-8
Table 2-10. MTR-3T Series Motor Specifications .....	2-10
Table 2-11 Mounting Configurations for Servo Motors.....	2-17
Table 3-1. Power Terminal Connections and Wire Sizes for SSD104 4.3 A Amplifier .....	3-23
Table 3-2. Power Terminal Connections and Wire Sizes for SSD107 7.2 A Amplifier .....	3-23
Table 3-3. Power Terminal Connections and Wire Sizes for SSD216 16A & SSD228 28A Amplifier ....	3-24
Table 3-4. Power Terminal Connections and Wire Sizes for SSD407 7.2 A 460 VAC Amplifier .....	3-24
Table 3-5. Power Terminal Connections and Wire Sizes for SSD420 20A Amplifier .....	3-25
Table 3-6. Serial Encoder Position Feedback Connections.....	3-26
Table 3-7. Resolver Position Feedback Connections .....	3-29
Table 3-8. Auxiliary I/O Connector Pin-out.....	3-31
Table 3-9. Cables Available from GE Fanuc.....	3-45
Table 3-10. S-Series Servo Motor Connector Mates.....	3-46
Table 3-11. Regenerative Discharge Resistor Kits.....	3-48
Table 3-12. Amplifier Regenerative Discharge Ratings.....	3-52
Table 6-1. LED Display Status Codes.....	6-1
Table C-1. Auxiliary Terminal Board Components .....	C-5
Table C-2. Terminal Block Pin Assignments for DSM300 Analog Servo Axes.....	C-7

# Chapter 1

## Before Operation

### 1.1 System Overview

S2K Series Brushless Servo Amplifiers are high performance amplifiers with user-configurable command interface and I/O functions. The amplifiers can accept either an analog torque or speed command, or a pulse (stepper) command interface. Amplifiers are available in models configured for either resolver or serial encoder motor feedback. Encoder based S2K models can only be used with GE Fanuc S-Series (SLM, SDM or SGM) servo motors. An S2K amplifier configured for resolver feedback can use GE Fanuc MTR-Series servo motors or third party motors with appropriate ratings and resolver specifications. The resolver must be a control transmitter type with a transformation ratio of 0.5. The ratio of motor poles to resolver poles must be an integer value 1, 2, or 3. For resolver motor requirements, refer to “Encoder Input and Output Specifications” in chapter 2. Please consult the factory for assistance in controlling non-GE Fanuc motors.

The following table lists the S2K Series servo amplifier power ratings that are available:

Voltage Rating	Current Rating	Input Power	Peak Current	Feedback Type
230 VAC	4.3 amps continuous 7.2 amps continuous	115 VAC single phase or 230 VAC 3-phase	2X continuous rating	resolver or serial
	16 amps continuous 28 amps continuous	230 VAC 3-phase		
460 VAC	7.2 amps continuous 20 amps continuous	460 VAC 3-phase	1.5X continuous rating	resolver only

S2K Series amplifiers are optimized for use with the GE Fanuc S-Series or MTR series servo motors. Overload and possible component damage may occur if the motor and amplifier are not properly matched. Tables 1-1 and 1-2 show the proper pairing of the components.

The 30—1000W S-Series servo motors (SLM models) are designed with standard NEMA shaft and flange mounting configurations for easy mounting to off-the-shelf gear reducers and couplings. The 750W motor uses an oversized shaft diameter (0.625 in.) for the NEMA 34 mounting to handle the peak torque rating of this model. SLM motors from 2.5 to 5kW, and all SDM and SGM models have metric mounting configurations. All servo motors are available with an optional 24VDC holding brake for holding stationary loads that is spring-set and electrically-released. You must supply a separate 24 VDC brake power supply. The 30—750W S-Series and all MTR-series motors have a pigtail cable with box style connectors for motor power, encoder, and brake connections for MTR-3T and 1-SKW S-Series motors. The 1000—5000W motors have MS style connectors, and brake power is integrated with the motor power connections in a common power connector/cable.

S2K Series amplifiers are configured using *Motion Developer* software running on a personal computer. This software is a standalone application that works in the Machine Edition software environment.

The following sections outline what should be accomplished before operating the S2K Series amplifiers.

## 1.2 Unpacking Components

After opening the S2K Series package, please verify the following:

1. Did you receive the correct model components? The model number of each component is shown on the carton and product labels.
2. Did you receive all items shown on the packing list?
3. Was anything damaged during shipment?

### Note

If you find any damage, please contact your local dealer/distributor or GE Fanuc directly.

## 1.3 Storage

Store S2K components in a clean, dry location that is not exposed to direct sunlight, rain, excessive temperatures (exceeding  $-20^{\circ}\text{C}$  to  $80^{\circ}\text{C}$ ), corrosive gasses or liquids.

For maximum protection, store all components in the original shipping container.

## 1.4 Part Numbers

The following figures show how to read the model number on the motors and S2K amplifiers.

### 1.4.1 Cable and Connector Part Numbers

GE Fanuc offers a variety of prefabricated and tested cables to simplify system installation. Part numbers for these cables and mating connectors are shown in Section 3.6.7.

## 1.4.2 Motor Part Numbers

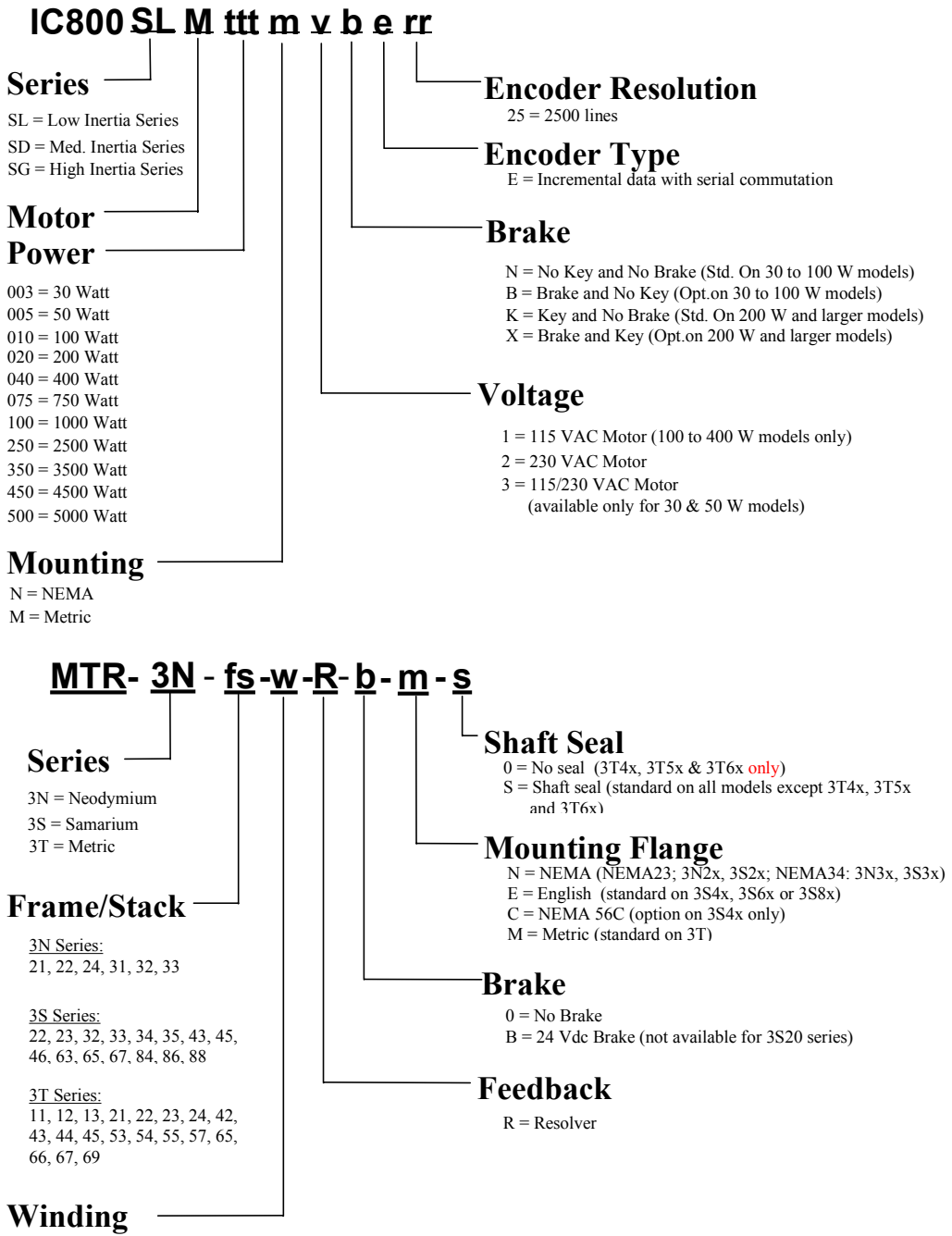

### 1.4.3 S2K Series Brushless Servo Amplifier Part Numbers

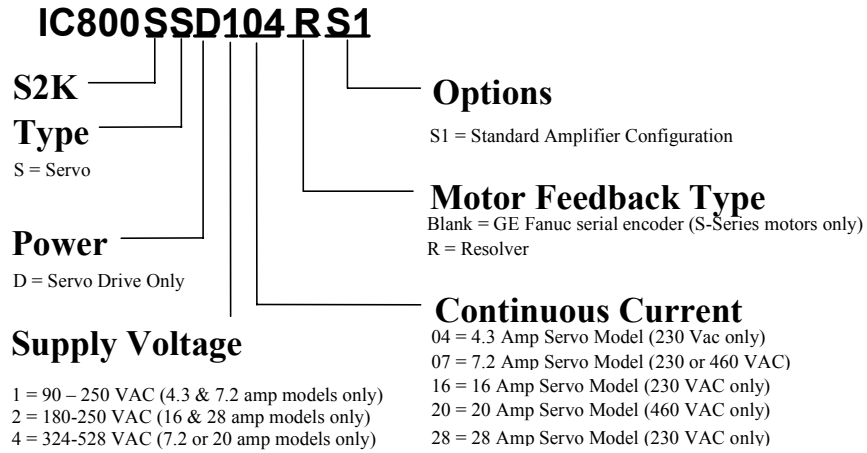

### 1.4.4 Accessory Part Numbers

#### 1.4.4.1 Regeneration Resistors

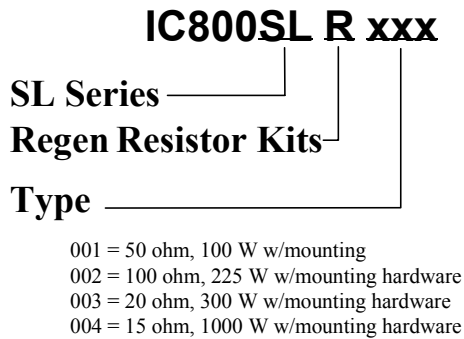

#### 1.4.4.2 Terminal Block Assemblies

**44A726268-001** – This terminal block can be used to interface a GE Fanuc APM300 series motion controller for the Series 90-30 PLC or other third party motion controller to the S2K amplifier.

**IC693ACC336** – This terminal block assembly can be used to interface a GE Fanuc DSM300 series motion control module for the Series 90-30 PLC to the S2K amplifier.

## 1.5 Confirming System Components

The S2K Series system consists of an amplifier and a servo motor from GE Fanuc. Each amplifier is optimized for use with specific GE Fanuc motors. However, a larger amplifier can be used if the continuous (CURC) and peak (CURP) current limit registers are set accordingly. Please refer to the following table for the correct combination of amplifier and motor.

**Table 1-1. S-Series Motor/Amplifier Compatibility for Serial Encoder-based Amplifiers**

Amplifier Model #	Applicable S-Series Motor					
	Motor Model #	Rated Output	Cont. Torque	Voltage	Max. Speed	Encoder Resolution (Quad Counts)
IC800SSD104S1	IC800SLM003N3NE25 IC800SLM003N3BE25*	30 W	0.84 in-lb	115/230VAC	5000	10,000 Counts
	IC800SLM005N3NE25 IC800SLM005N3BE25*	50 W	1.42 in-lb	115/230VAC	5000	10,000 Counts
	IC800SLM010N1NE25 IC800SLM010N1BE25*	100 W	2.83 in-lb	115VAC	5000	10,000 Counts
	IC800SLM010N2NE25 IC800SLM010N2BE25*	100 W	2.83 in-lb	230VAC	5000	10,000 Counts
	IC800SLM020N1KE25 IC800SLM020N1XE25*	200 W	5.7 in-lb	115VAC	5000	10,000 Counts
	IC800SLM020N2KE25 IC800SLM020N2XE25*	200 W	5.7 in-lb	230VAC	5000	10,000 Counts
	IC800SLM040N1KE25 IC800SLM040N1XE25*	400 W	11.5 in-lb	115VAC	5000	10,000 Counts
	IC800SLM040N2KE25 IC800SLM040N2XE25*	400 W	11.5 in-lb	230VAC	5000	10,000 Counts
	IC800SLM075N2KE25 IC800SLM075N2XE25*	750 W	21 in-lb	230VAC	5000	10,000 Counts
IC800SSD107S1	IC800SLM100N2KE25 IC800SLM100N2XE25*	1000 W	28 in-lb	230VAC	5000	10,000 Counts
	IC800SDM100M2KE25 IC800SDM100M2XE25*	1000 W	43 in-lb	230VAC	3000	10,000 Counts
IC800SSD216S1	IC800SLM250M2KE25 IC800SLM250M2XE25*	2500 W	70 in-lb	230VAC	5000	10,000 Counts
	IC800SDM250M2KE25 IC800SDM250M2XE25*	2500 W	104 in-lb	230VAC	3000	10,000 Counts
IC800SSD228S1	IC800SLM350M2KE25 IC800SLM350M2XE25*	5000 W	140 in-lb	230VAC	5000	10,000 Counts
	IC800SLM500M2KE25 IC800SLM500M2XE25*	5000 W	140 in-lb	230VAC	4500	10,000 Counts
	IC800SDM500M2KE25 IC800SDM500M2XE25*	5000 W	210 in-lb	230VAC	3000	10,000 Counts
	IC800SGM450M2KE25 IC800SGM450M2XE25*	4500 W	322 in-lb	230VAC	2000	10,000 Counts

\* Denotes motors that have the optional 24 VDC holding brake (requires customer supplied power supply)

Table 1-2. MTR-Series Motor/Amplifier Compatibility for Resolver-based Amplifiers

Amplifier Model #	Applicable MTR-Series Motor				
	Motor Model #	Cont. Stall Torque	Voltage	Max. Speed	Resolver Resolution
IC800SSD104RS1	MTR-3N21-H	4 in-lb	230VAC	14000	4096 counts
	MTR-3N22-H	9 in-lb	230VAC	11000	4096 counts
	MTR-3N24-G	13.8 in-lb	230VAC	5000	4096 counts
	MTR-3N31-H	18 in-lb	230VAC	5500	4096 counts
	MTR-3N32-G	36 in-lb	230VAC	3000	4096 counts
	MTR-3N33-G	45 in-lb	230VAC	2100	4096 counts
	MTR-3S22-G	4.8 in-lb	230VAC	8000	4096 counts
	MTR-3S23-G	8 in-lb	230VAC	4700	4096 counts
	MTR-3S32-G	14 in-lb	230VAC	5500	4096 counts
	MTR-3S33-G	21 in-lb	230VAC	4400	4096 counts
	MTR-3S34-G	27 in-lb	230VAC	3300	4096 counts
	MTR-3S35-G	32 in-lb	230VAC	2500	4096 counts
	MTR-3S43-G	33 in-lb	230VAC	2600	4096 counts
	MTR-3T11-G	2.3 in-lb	230VAC	6000	4096 counts
	MTR-3T12-G	5.3 in-lb	230VAC	6000	4096 counts
	MTR-3T13-G	8 in-lb	230VAC	6000	4096 counts
	MTR-3T21-G	5.6 in-lb	230VAC	9250	4096 counts
	MTR-3T22-G	11.5 in-lb	230VAC	7100	4096 counts
	MTR-3T23-G	17.7 in-lb	230VAC	4700	4096 counts
	IC800SSD107RS1	MTR-3T24-H	23 in-lb	230VAC	4350
MTR-3T42-H		33 in-lb	230VAC	2600	4096 counts
MTR-3T43-H		54 in-lb	230VAC	2600	4096 counts
MTR-3N24-H		14 in-lb	230VAC	9800	4096 counts
MTR-3N32-H		36 in-lb	230VAC	6000	4096 counts
MTR-3N33-H		45 in-lb	230VAC	4000	4096 counts
MTR-3S43-H		33 in-lb	230VAC	4200	4096 counts
MTR-3S45-G		48 in-lb	230VAC	2800	4096 counts
MTR-3S46-G		64 in-lb	230VAC	2100	4096 counts
MTR-3T43-J	54 in-lb	230VAC	4000	4096 counts	
MTR-3T44-J	72 in-lb	230VAC	3000	4096 counts	
MTR-3T45-H	90 in-lb	230VAC	2350	4096 counts	

Amplifier Model #	Applicable MTR-Series Motor				
	Motor Model #	Cont. Stall Torque	Voltage	Max. Speed	Resolver Resolution
IC800SSD216RS1	MTR-3S45-H	48 in-lb	230VAC	5600	4096 counts
	MTR-3S46-H	64 in-lb	230VAC	4200	4096 counts
	MTR-3S63-G	70 in-lb	230VAC	3850	4096 counts
	MTR-3S65-G	115 in-lb	230VAC	2300	4096 counts
	MTR-3S67-G	168 in-lb	230VAC	1650	4096 counts
	MTR-3T45-I	90 in-lb	230VAC	3300	4096 counts
	MTR-3T54-H	120 in-lb	230VAC	2700	4096 counts
	MTR-3T55-H	151 in-lb	230VAC	2150	4096 counts
IC800SSD228RS1	MTR-3S63-H	70 in-lb	230VAC	7700	4096 counts
	MTR-3S65-H	115 in-lb	230VAC	4600	4096 counts
	MTR-3S67-H	168 in-lb	230VAC	3300	4096 counts
	MTR-3S84-G	190 in-lb	230VAC	3400	4096 counts
	MTR-3S86-G	255 in-lb	230VAC	2600	4096 counts
	MTR-3S88-G	338 in-lb	230VAC	2000	4096 counts
	MTR-3T55-I	151 in-lb	230VAC	4300	4096 counts
	MTR-3T57-H	195 in-lb	230VAC	3050	4096 counts
	MTR-3T66-H	319 in-lb	230VAC	2000	4096 counts
	MTR-3T67-G	372 in-lb	230VAC	1700	4096 counts
	MTR-3T69-G	478 in-lb	230VAC	1300	4096 counts
IC800SSD407RS1	MTR-3T45-H	90 in-lb	460VAC	4750	4096 counts
	MTR-3T45-I	90 in-lb	460VAC	6500	4096 counts
IC800SSD420RS1	MTR-3T54-H	120 in-lb	460VAC	5400	4096 counts
	MTR-3T55-H	151 in-lb	460VAC	4300	4096 counts

## 1.6 Agency Approvals

Product Series	UL/UR	CUL/CUR	CE
S2K Amplifiers	UL	CUL	EN50178
MTR-3N Series Motors	UR	No	EN60034-1
MTR-3S Series Motors	UR	No	EN60034-1
MTR-3T Series Motors	UR	CUR	EN60034-1

# Chapter 2

## Hardware Overview

---

---

### 2.1 Specifications

The S2K Series amplifiers are available in two 115/230 VAC ratings, two 230 VAC ratings and two 460 VAC ratings. The 115/230 VAC and 230 VAC models are available with either a serial encoder or resolver motor feedback interface while the 460 VAC models are only available with a resolver feedback interface. The S2K series encoder-based amplifiers are used with the S-Series servo motors while the resolver-based amplifiers are used with MTR-Series servo motors. This chapter contains the specifications for each of these components. Table 2-1 shows the hardware resources available on the S2K amplifiers.

**Table 2-1. Hardware Resources**

Hardware Resources	S2K Amplifier
Motor Feedback Input (serial encoder or resolver)	1
Auxiliary Encoder Input	1
Encoder Output	1
Enable Digital Inputs	1
OK Digital Outputs	1
Analog Inputs	2
Analog Outputs	1
Serial Ports	1

#### 2.1.1 Electrical Specifications

The Servo Controller models are suitable for use on a circuit capable of delivering not more than 5,000 rms symmetrical amperes, 250 volts maximum when protected by RK5 class fuses. Table 2-2 summarizes the *maximum continuous* input power requirements. The actual input power and current is a function of the motor's operating point and the duty cycle.

Table 2-2. Amplifier Power Specifications

Specification	Units	Rating					
		SSD104	SSD107	SSD216	SSD228	SSD407	SSD420
AC Input Voltage Range	VAC	90-250, 1 or 3 phase		180-250, 3 phase		324-528, 3 phase	
AC Input Frequency Range	Hz	50 - 440					
PWM Frequency to Motor	kHz	16.4			8.2		
Motor Minimum Inductance	mH	1 (per phase)					
Cont. Output Current <sup>1</sup>	A <sub>rms</sub>	4.3	7.2	16	28	7.2	20
Peak Output Current	A <sub>rms</sub>	8.6	14.4	32	56	10.8	20
Max. Input Current 1-phase 3-phase	A <sub>rms</sub>	7	15	N/A	N/A	N/A	N/A
	A <sub>rms</sub>	4	8	18	30	8	22
Max. Input Power	KVA @ Rated VAC	1.6	3.8	8.5	14.3	6.4	18
Logic Input Power	VAC	N/A	N/A	90-250 @ 0.5 A		+18-30 VDC @ 1.5 A	
DC Power Outputs <sup>3</sup>	VDC	+5 @ 0.25 A; +12 @ 0.5 A					
Logic Supply Fuses	<b>SSD104:</b> No internal fuses <b>SSD107, SSD216, and SSD228:</b> 2A, 250 volt fuse (Littelfuse #224002) on the 2L1 input only. The 2L2 input is not fused. This fuse is soldered in and is not considered field replaceable. <b>IC800SSD407 and IC800SSD420:</b> 5A, 125 volt fuse (Littelfuse #251005) on the +24 V input only. The COM input is not fused. This fuse is soldered in and is not considered field replaceable.						
Branch Circuit Fuse <sup>2</sup> 1-phase 3-phase	A <sub>rms</sub>	10	15	N/A	N/A	N/A	N/A
	A <sub>rms</sub>	5	15	20	30	10	25

Notes:

- 1) Outputs are provided with an internal overload protection
- 2) Use RK5 class time delay fuses for the supply line
- 3) The +5 Vdc output is also used to power the S-Series motor encoder. The +5V supply can source 0.5 A but the motor encoder requires 0.25 amp max. (0.15 amp typical). This supply is protected against overload but overloading will cause a loss of motor feedback and the system will fault.

## 2.1.2 Isolation Transformer

An isolation transformer is not specifically required when using the S2K Series amplifiers. If the supply voltage is above the maximum of the range specified for each model a transformer is required to drop the voltage to within the acceptable range. The transformer should be sized to provide adequate power under all operating conditions. Choose a transformer rated for a minimum of 125% of the drive maximum continuous input KVA.

## 2.1.3 Environmental Specifications

Table 2-3. Environmental Specifications

Operating Temperature <sup>1</sup>	32 to 122 °F (0 to 50 °C)
Storage and Shipping Temperature	-40 to 176 °F (-40 to 80 °C)
Altitude <sup>2</sup>	3300 Feet (1000 m)
Relative Humidity (non-condensing)	5 to 95 %

Notes:

- 1) Assumes heat sink orientation is vertical
- 2) Operation at higher altitudes requires controller derating. Please consult GE Fanuc.

## 2.1.4 Communication Specifications

Table 2-4. Serial Communication Specifications

Serial Communication	
Available Ports	1
Format	RS-232
Maximum Addressable Units	1
Maximum Length of Serial Data Link	50 feet
Communication Rate	9600 baud
Data Bits	7
Parity	Odd
Stop Bits	1
Flow Control	XON/XOFF

## 2.1.5 Input And Output Specifications

Table 2-5. Input and Output Specifications

Digital Inputs and Outputs		
Operating Range	12-24 VDC, 30 VDC maximum	
Interface Format	optically isolated, source/sink user-configurable	
Inputs	Maximum Off Voltage	4 VDC
	Minimum On Voltage	10 VDC
	Load	2 k $\Omega$
Outputs	Maximum On Resistance	35 Ohms
	Maximum Load Current	100 mA
	Maximum Off Leakage Current	200 nA
Analog Inputs		
Number Available	2	
Operating Range	+/-10 VDC	
Resolution	12 Bits	
Input Impedance	50 k $\Omega$	
Analog Outputs		
Number Available	1	
Functional Assignment	User configurable as velocity, current or following error	
Operating Range	+/-10 VDC	
Resolution	8 Bits	
Output Current	5mA	

## 2.1.6 Encoder Input And Output Specifications

Table 2-6. Encoder and Resolver Input/Output Specifications

<b>Auxiliary Encoder Input</b>	
Number Available	1
Input Voltage	5, 12 or 15 VDC
Input Format	Single-ended or Differential Sine or Square Wave Quadrature, Pulse/Direction or CW/CCW Pulse
Max. Line Count Frequency	3 MHz (12 MHz quadrature)
+5 Supply <sup>1</sup>	0.35 A max. (0.25 A typical)
<b>Encoder Output</b>	
Number Available	1
Output Voltage	5 VDC
Output Format	Differential Square Wave Quadrature, Pulse/Direction or CW/CCW Pulse
Max. Line Count Frequency	250 kHz
<b>Motor Encoder Feedback Input (Serial encoder-based models only)</b>	
Number Available	1
Resolution	2500 lines per revolution
Data Input Format	Differential, Quadrature
Commutation Input Format	Serial (S-Series motors)
Max. Line Count Frequency	3 MHz (12 MHz quadrature)
Motor Encoder Current Requirement <sup>1</sup>	typical 0.150 A maximum 0.250 A
<b>Motor Resolver Feedback Input (Resolver-based models only)</b>	
Number Available	1
Resolution	4096 pulses per revolution
Maximum Speed	15,000 RPM
Type	Control Transmitter
Phase Shift	± 5.0 degrees @ 5kHz
Null Voltage	< 20 mV @ 5 kHz
Transformation Ratio	0.5

Notes

- 1) The +5 Vdc output power supply available to power the auxiliary encoder ( pin 19 of the Auxiliary I/O connector for models SSD104, SSD107 and SSD407 or the Pulse Input connector on models SSD216, SSD228 and SSD420) is also used to power the motor encoder. The motor encoder requires a maximum of 0.25 amps but typically draws 0.15 amp. Overloading the 5V supply will cause a loss of feedback and fault the amplifier.

## 2.1.7 Servo Motor Specifications

Table 2-7. S-Series Motor Specifications

Specification	Units	Motor Rating @ 20°C								
		SLM003	SLM005	SLM010		SLM020		SLM040		SLM075
		115/230V	115/230V	115V	230V	115V	230V	115V	230V	230V
Output Power	W	30	50	100		200		400		750
Continuous Stall Torque <sup>1</sup>	in-lb [Nm]	0.84 [0.095]	1.42 [0.16]	2.83 [0.32]		5.66 [0.64]		11.5 [1.3]		21.2 [2.4]
Peak Torque	in-lb [Nm]	2.48 [0.28]	4.25 [0.48]	8.0 [0.95]		16.9 [1.91]		33.6 [3.8]		46.0 [5.2]
Rated Speed	RPM	3000	3000	3000		3000		3000		3000
Maximum Speed	RPM	5000	5000	5000		5000		5000		4500
Feedback		2500 lines (10,000 counts/rev) Incremental Encoder (5 VDC±5% @ 0.3A; 250 kHz max.)								
Weight	lb [kg]	0.59 [0.27]	0.75 [0.34]	1.23 [0.56]		2.2 [1.0]		3.52 [1.6]		7.0 [3.2]
Rotor Inertia	in-lb-s <sup>2</sup> x 10 <sup>-4</sup> [kg-m <sup>2</sup> x 10 <sup>-4</sup> ]	0.139 [0.016]	0.225 [0.025]	0.546 [0.062]		1.474 [0.17]		3.208 [0.36]		11.62 [1.31]
Shaft Thrust Load	lb [kg]	6.6 [3]	13.2 [6]	13.2 [6]		22 [10]		22 [10]		33 [15]
Shaft Radial Load <sup>2</sup>	lb [kg]	11 [5]	15.4 [7]	15.4 [7]		55 [25]		55 [25]		88 [40]
Mechanical Time Constant	ms	1.8	1.2	0.8	0.77	0.62	0.63	0.48	0.54	0.45
Torque Constant	in-lb/A <sub>(rms)</sub> [Nm/A <sub>(rms)</sub> ]	0.91 [0.103]	1.42 [0.16]	1.86 [0.21]	3.28 [0.37]	2.39 [0.27]	3.72 [0.42]	2.66 [0.30]	4.78 [0.54]	5.4 [0.61]
Resistance (phase)	Ohms	4.0	4.2	1.9	5.7	0.91	2.3	0.41	1.46	0.43
Inductance (phase)	mH	2.4	2.8	1.7	5.0	3.2	7.8	1.9	5.1	3.2
Electrical Time Constant	ms	0.6	0.67	0.89	0.88	3.5	3.4	4.6	3.5	7.4
Continuous Current	A <sub>(rms)</sub>	1.0	1.0	1.6	1.0	2.5	1.6	4.3	2.5	4.3
<b>Optional Brake Data @ 20 °C (backlash = ±0.1°)</b>										
Inertia Adder	in-lb-s <sup>2</sup> x 10 <sup>-4</sup> [kg-m <sup>2</sup> x 10 <sup>-4</sup> ]	0.026 [0.003]	0.026 [0.003]	0.026 [0.003]		0.26 [0.03]		0.26 [0.03]		0.78 [0.09]
Weight Adder	lb [kg]	0.44 [0.2]	0.42 [0.19]	0.44 [0.2]		0.88 [0.4]		0.88 [0.4]		1.54 [0.7]
Voltage	VDC± 10%	24	24	24		24		24		24
Current	A	0.26	0.26	0.26		0.36		0.36		0.43
Engage Time	ms	≤ 25	≤ 25	≤ 25		≤ 50		≤ 50		≤ 60
Release Time	ms	≤ 20	≤ 20	≤ 20		≤ 15		≤ 15		≤ 15
Torque	in-lb [Nm]	2.6 [0.29]	2.6 [0.29]	2.6 [0.29]		10.8 [1.3]		10.8 [1.3]		21.7 [2.5]
<b>Environmental Data</b>										
Humidity (non-condensing)	RH	85%								
Ambient Temperature (operating)	°C	0 to 40								
Storage Temperature	°C	-20 to 80								
Vibration <sup>3</sup>	G	5								
Shock	G	10								

1. Torque shown is available up to a certain ambient temperature. See Speed/Torque curve notes.

2. Radial shaft loads are specified at a position centered along the length of the shaft

3. Vibration tests are described in the section “Motor Vibration Testing” later in this chapter.

Specification	Units	Motor Rating @ 20°C							
		SDM100	SLM100	SLM250	SDM250	SLM350	SLM500	SDM500	SGM450
Output Power	W	1000	1000	2500	2500	3500	5000	5000	5000
Continuous Stall Torque <sup>1</sup>	in-lb [Nm]	43 [4.8]	28 [3.18]	70 [7.94]	104 [11.8]	97 [11]	140 [15.8]	210 [23.8]	322 [36.3]
Peak Torque	in-lb [Nm]	110 [12.4]	56 [6.3]	140 [15.8]	240 [27.1]	252 [28.5]	421 [47.6]	420 [47.5]	644 [72.8]
Rated Speed	RPM	2000	3000	3000	2000	3000	3000	2000	3000
Maximum Speed	RPM	3000	5000	5000	3000	5000	4500	3000	4500
Feedback		2500 lines (10,000 counts/rev) Incremental Encoder (5 VDC ±5% @0.3 A; 250 kHz max.)							
Weight	lb [kg]	15 [6.8]	9.9 [4.5]	16.5 [7.5]	28.2 [12.8]	24 [10.9]	38 [17.3]	55 [25]	38 [17.3]
Rotor Inertia	in-lb-s <sup>2</sup> x 10 <sup>-4</sup> [kg-m <sup>2</sup> x 10 <sup>-4</sup> ]	54.6 [6.17]	14.91 [1.69]	38.14 [4.31]	169.9 [19.2]	69.92 [7.90]	157.5 [17.8]	537.2 [60.7]	157.5 [17.8]
Shaft Thrust Load	lb [kg]	44 [20]	33 [15]	44 [20]	77 [35]	44 [20]	77 [35]	77 [35]	77 [35]
Shaft Radial Load <sup>2</sup>	lb [kg]	110 [50]	88 [40]	110 [50]	176 [80]	110 [50]	176 [80]	176 [80]	176 [80]
Mechanical Time Constant	ms	0.70	0.78	0.52	0.72	0.45	0.46	0.9	0.46
Torque Constant	in-lb/A <sub>(rms)</sub> [Nm/A <sub>(rms)</sub> ]	7.61 [0.86]	3.9 [0.44]	4.34 [0.49]	7.52 [0.85]	4.51 [0.51]	5.04 [0.57]	7.52 [0.85]	11.5 [1.3]
Resistance (phase)	Ohms	0.56	0.27	0.1	0.18	0.05	0.028	0.068	0.028
Inductance (phase)	mH	10.0	1.8	1.1	3.8	1	1.12	2.2	0.56
Electrical Time Constant	ms	18	6.7	11	21	20	20	32	20
Continuous Current	A <sub>(rms)</sub>	5.6	7.2	15.9	14	21.6	28	28	28.5
<b>Optional Brake Data @ 20 °C (backlash = ± 0.1°)</b>									
Inertia Adder	in-lb-s <sup>2</sup> x 10 <sup>-4</sup> [kg-m <sup>2</sup> x 10 <sup>-4</sup> ]	5.49 [0.62]	2.25 [0.26]	3.81 [0.43]	16.82 [1.9]	6.99 [0.79]	16.82 [1.9]	53.1 [6]	16.82 [1.9]
Weight Adder	lb [kg]	4.2 [1.9]	1.32 [0.6]	3.08 [1.4]	4.2 [1.9]	3.74 [1.7]	4.18 [1.9]	7.7 [3.5]	4.18 [1.9]
Voltage	VDC ± 10%	24	24	24	24	24	24	24	24
Current	A	0.59	0.74	0.81	0.9	0.81	0.90	1.3	0.90
Engage Time	ms	≤ 80	≤ 50	≤ 50	≤ 110	≤ 80	≤ 110	≤ 80	≤ 110
Release Time	ms	≤ 70	≤ 15	≤ 15	≤ 50	≤ 15	≤ 50	≤ 25	≤ 50
Torque	in-lb [Nm]	43.3 [4.9]	43.3 [4.9]	69 [7.8]	143 [16.1]	104 [11.8]	143 [16.2]	217 [24.5]	143 [16.2]
<b>Environmental Data</b>									
Humidity (non-condensing)	RH	85%							
Ambient Temperature (operating)	°C	0 to 40							
Storage Temperature	°C	-20 to 80							

1. Torque shown is available up to a certain ambient temperature. See Speed/Torque curve notes.

2. Radial shaft loads are specified at a position centered along the length of the shaft

3. Vibration tests are described in the section "Motor Vibration Testing" later in this chapter.

Table 2-8. MTR-3N Series Motor Specifications

Specification	Units	3N21-H	3N22-H	3N24-G	3N31-H	3N32-G	3N32-H	3N33-G	3N33-H
Continuous Stall Torque <sup>1</sup>	in-lb [Nm]	4 [0.45]	9 [1.02]	13.8 [1.56]	18 [2.03]	36 [4.07]	36 [4.07]	45 [5.08]	45 [5.08]
Peak Torque <sup>3</sup>	in-lb [Nm]	12 [1.36]	23.4 [2.64]	43.7 [4.94]	55 [6.2]	100 [11.3]	100 [11.3]	135 [15.3]	224 [25.3]
Maximum Speed	RPM	14,000	11,000	5000	5500	3000	6000	2100	4000
Feedback	4096 counts/rev resolver (control transmitter; 0.5 transformation ratio)								
Weight	lb [kg]	3.1 [1.4]	4.2 [1.9]	6.0 [2.7]	7.1 [3.2]	10.7 [4.9]	10.7 [4.9]	14.2 [6.5]	14.2 [6.5]
Rotor Inertia	in-lb-s <sup>2</sup> x 10 <sup>-4</sup> [kg-m <sup>2</sup> x 10 <sup>-4</sup> ]	3.8 [0.42]	5.6 [0.64]	8.9 [1.0]	29.8 [3.4]	42.8 [4.8]	42.8 [4.8]	56.8 [6.4]	56.8 [6.4]
Shaft Thrust Load <sup>2</sup>	lb [kg]	20 [9.1]	20 [9.1]	20 [9.1]	35 [15.9]	35 [15.9]	35 [15.9]	35 [15.9]	35 [15.9]
Shaft Radial Load <sup>2</sup>	lb [kg]	50 [22.7]	50 [22.7]	50 [22.7]	85 [38.6]	85 [38.6]	85 [38.6]	85 [38.6]	85 [38.6]
Torque Constant	in-lb/A <sub>(rms)</sub> [Nm/A <sub>(rms)</sub> ]	1.8 [0.26]	2.7 [0.3]	5.3 [0.6]	6.2 [0.7]	11.5 [1.3]	6.2 [0.7]	16.8 [1.9]	8.0 [0.9]
Resistance (line-line)	Ohms	3.0	4.2	6.8	4.1	6.2	1.6	8.4	2.1
Inductance (line-line)	mH	3.7	5.7	9.3	10.3	18	4.5	25.2	6.3
Electrical Time Constant	ms	1.23	1.36	1.37	2.51	2.9	2.81	3.0	3.0
Continuous Current	A <sub>(rms)</sub>	3.1	2.9	2.6	3.3	3.1	5.1	2.8	5.6
<b>Optional Brake Data</b>									
Inertia Adder	in-lb-s <sup>2</sup> x 10 <sup>-4</sup> [kg-m <sup>2</sup> x 10 <sup>-4</sup> ]	0.45 [0.05]	0.45 [0.05]	0.45 [0.05]	2.5 [0.282]	2.5 [0.282]	2.5 [0.282]	2.5 [0.282]	2.5 [0.282]
Weight Adder	lb [kg]	1.1 [0.5]	1.1 [0.5]	1.1 [0.5]	2.5 [1.14]	2.5 [1.14]	2.5 [1.14]	2.5 [1.14]	2.5 [1.14]
Voltage	VDC ± 10%	24	24	24	24	24	24	24	24
Current	A	0.38	0.38	0.38	0.72	0.72	0.72	0.72	0.72
Engage Time	ms	40	40	40	10	10	10	10	10
Release Time	ms	25	25	25	30	30	30	30	30
Torque	in-lb [Nm]	10 [1.1]	10 [1.1]	10 [1.1]	32 [3.62]	32 [3.62]	32 [3.62]	32 [3.62]	32 [3.62]
<b>Environmental Data</b>									
Humidity (non-condensing)	RH	98%							
Ambient Temperature (operating)	°C	-20 to 40							
Storage Temperature	°C	-30 to 150							

1. Torque shown is available up to an ambient temperature of 25° C with motor mounted to a 10' x10' x 0.25' aluminum heat sink.

2. Shaft loads are based on L10 bearing life at 3000 rpm and assume force is applied to center of shaft.

3. Peak torque ratings are for the motor only and may be limited by the specific amplifier based on the amplifiers peak current limitations.

Table 2-9. MTR-3S Series Motor Specifications

Specification	Units	3S22-G	3S23-G	3S32-G	3S33-G	3S34-G	3S35-G	3S43-G	3S43-H	3S45-G	3S45-H
Continuous Stall Torque <sup>1</sup>	in-lb [Nm]	4.8 [0.54]	8.0 [0.9]	14 [1.58]	21 [2.37]	27 [3.05]	32 [3.62]	33 [3.73]	33 [3.73]	48 [5.42]	48 [5.42]
Peak Torque <sup>3</sup>	in-lb [Nm]	14.3 [1.62]	22.5 [2.54]	39 [4.4]	57.9 [6.54]	73.5 [8.30]	89.4 [10.1]	92.1 [10.4]	92.1 [10.4]	134 [15.1]	134 [15.1]
Maximum Speed	RPM	8000	4700	5500	4400	3300	2500	2600	4200	2800	2350
Feedback		4096 counts/rev resolver (control transmitter; 0.5 transformation ratio)									
Weight	lb [kg]	2.1 [0.95]	2.8 [1.3]	5.5 [2.5]	7.1 [3.2]	8.7 [3.9]	10.2 [4.6]	15 [6.8]	15 [6.8]	20 [9.1]	20 [9.1]
Rotor Inertia	in-lb-s <sup>2</sup> x 10 <sup>-4</sup> [kg-m <sup>2</sup> x 10 <sup>-4</sup> ]	1.2 [0.14]	1.6 [0.18]	6.3 [0.71]	8.2 [0.93]	10.0 [1.1]	11.9 [1.3]	19.8 [2.2]	19.8 [2.2]	27.8 [3.1]	27.8 [3.1]
Shaft Thrust Load <sup>2</sup>	lb [kg]	20 [9.1]	20 [9.1]	35 [15.9]	35 [15.9]	35 [15.9]	35 [15.9]	50 [22.7]	50 [22.7]	50 [22.7]	50 [22.7]
Shaft Radial Load <sup>2</sup>	lb [kg]	50 [22.7]	50 [22.7]	90 [40.9]	90 [40.9]	90 [40.9]	90 [40.9]	125 [56.8]	125 [56.8]	125 [56.8]	125 [56.8]
Torque Constant	in-lb/A <sub>(rms)</sub> [Nm/A <sub>(rms)</sub> ]	3.5 [0.4]	5.3 [0.6]	5.3 [0.6]	7.1 [0.8]	9.7 [1.1]	11.5 [1.3]	11.5 [1.3]	6.2 [0.7]	8.9 [1.0]	4.4 [0.5]
Resistance (phase)	Ohms	22	20	7.3	6.9	8.1	9.2	10	2.5	3.2	0.81
Inductance (phase)	mH	21	26	23	22	30	42	53	13.3	20	4.9
Electrical Time Constant	ms	0.95	1.3	3.2	3.2	3.7	4.6	5.3	5.3	6.3	6.1
Continuous Current	A <sub>(rms)</sub>	1.4	1.5	2.9	3.2	3.0	2.9	2.9	5.6	5.5	10.9
<b>Optional Brake Data</b>											
Inertia Adder	in-lb-s <sup>2</sup> x 10 <sup>-4</sup> [kg-m <sup>2</sup> x 10 <sup>-4</sup> ]	N/A	N/A	0.34 [0.38]	0.34 [0.38]	0.34 [0.38]	0.34 [0.38]	5.0 [0.565]	5.0 [0.565]	5.0 [0.565]	5.0 [0.565]
Weight Adder	lb [kg]	N/A	N/A	2.5 [1.14]	2.5 [1.14]	2.5 [1.14]	2.5 [1.14]	4.0 [1.82]	4.0 [1.82]	4.0 [1.82]	4.0 [1.82]
Voltage	VDC ± 10%	N/A	N/A	24	24	24	24	24	24	24	24
Current	A	N/A	N/A	0.72	0.72	0.72	0.72	0.71	0.71	0.71	0.71
Engage Time	ms	N/A	N/A	10	10	10	10	20	20	20	20
Release Time	ms	N/A	N/A	30	30	30	30	120	120	120	120
Torque	in-lb [Nm]	N/A	N/A	32 [3.62]	32 [3.62]	32 [3.62]	32 [3.62]	72 [8.14]	72 [8.14]	72 [8.14]	72 [8.14]
<b>Environmental Data</b>											
Humidity (non-condensing)	RH	98%									
Ambient Temperature (operating)	°C	-20 to 40									
Storage Temperature	°C	-30 to 150									

1. Torque shown is available up to an ambient temperature of 25° C with motor mounted to a 10' x10' x 0.25' aluminum heat sink.

2. Shaft loads are based on L10 bearing life at 3000 rpm and assume force is applied to center of shaft.

3. Peak torque ratings are for the motor only and may be limited by the specific amplifier based on the amplifiers peak current limitations.

Specification	Units	3S46-G	3S46-H	3S63-G	3S63-H	3S65-G	3S65-H	3S67-G	3S67-H	3S84-G	3S86-G	3S88-G
Continuous Stall Torque <sup>1</sup>	in-lb [Nm]	64 [7.23]	64 [7.23]	70 [7.9]	70 [7.9]	115 [13]	115 [13]	168 [19]	168 [19]	190 [21.5]	255 [28.8]	338 [38.2]
Peak Torque <sup>3</sup>	in-lb [Nm]	179 [20.2]	179 [20.2]	181 [20.5]	181 [20.5]	295 [33.3]	295 [33.3]	433 [48.9]	433 [48.9]	394 [44.5]	590 [66.6]	762 [86.1]
Maximum Speed	RPM	2100	4200	3850	7700	2300	4600	1650	3300	3400	2600	2600
Feedback		4096 counts/rev resolver (control transmitter; 0.5 transformation ratio)										
Weight	lb [kg]	25 [11.3]	25 [11.3]	29 [13]	29 [13]	39 [18]	39 [18]	49 [22]	49 [22]	60 [27]	77 [35]	94 [43]
Rotor Inertia	in-lb-s <sup>2</sup> x 10 <sup>-4</sup> [kg-m <sup>2</sup> x 10 <sup>-4</sup> ]	35.8 [4.0]	35.8 [4.0]	72 [8.1]	72 [8.1]	112 [12.6]	112 [12.6]	152 [17.2]	152 [17.2]	392 [44.3]	582 [65.7]	762 [86.1]
Shaft Thrust Load <sup>2</sup>	lb [kg]	50 [22.7]	50 [22.7]	70 [32]	70 [32]	70 [32]	70 [32]	70 [32]	70 [32]	100 [45]	100 [45]	100 [45]
Shaft Radial Load <sup>2</sup>	lb [kg]	125 [56.8]	125 [56.8]	185 [84]	185 [84]	185 [84]	185 [84]	185 [84]	185 [84]	250 [114]	250 [114]	250 [114]
Torque Constant	in-lb/A <sub>(rms)</sub> [Nm/A <sub>(rms)</sub> ]	12.4 [1.4]	6.2 [0.7]	7.1 [0.8]	3.5 [0.40]	11.5 [1.30]	5.3 [0.6]	15.9 [1.8]	8.0 [0.9]	7.1 [0.8]	9.7 [1.1]	12.4 [1.4]
Resistance (phase)	Ohms	3.7	0.93	0.93	0.23	1.2	0.34	1.5	0.37	0.26	0.25	0.28
Inductance (phase)	mH	25	6.2	8.9	2.2	13.7	3.4	18.2	4.6	3.2	3.6	4.0
Electrical Time Constant	ms	6.8	6.7	9.6	9.6	11.4	10.0	12.1	12.4	12.3	14.4	14.2
Continuous Current	A <sub>(rms)</sub>	5.5	11	11	22	10.7	21.4	11.3	22.5	26.9	30.2	29.4
<b>Optional Brake Data</b>												
Inertia Adder	in-lb-s <sup>2</sup> x 10 <sup>-4</sup> [kg-m <sup>2</sup> x 10 <sup>-4</sup> ]	5.0 [0.565]	5.0 [0.565]	3.7 [0.418]	3.7 [0.418]	3.7 [0.418]	3.7 [0.418]	3.7 [0.418]	3.7 [0.418]	14.9 [1.68]	14.9 [1.68]	14.9 [1.68]
Weight Adder	lb [kg]	4.0 [1.82]	4.0 [1.82]	9 [4.1]	9 [4.1]	9 [4.1]	9 [4.1]	9 [4.1]	9 [4.1]	15 [6.82]	15 [6.82]	15 [6.82]
Voltage	VDC± 10%	24	24	24	24	24	24	24	24	24	24	24
Current	A	0.71	0.71	1.14	1.14	1.14	1.14	1.14	1.14	1.51	1.51	1.51
Engage Time	ms	20	20	25	25	25	25	25	25	50	50	50
Release Time	ms	120	120	50	50	50	50	50	50	100	100	100
Torque	in-lb [Nm]	72 [8.14]	72 [8.14]	180 [20.3]	180 [20.3]	180 [20.3]	180 [20.3]	180 [20.3]	180 [20.3]	180 [20.3]	180 [20.3]	180 [20.3]
<b>Environmental Data</b>												
Humidity (non-condensing)	RH	98%										
Ambient Temperature (operating)	°C	-20 to 40										
Storage Temperature	°C	-30 to 150										

1. Torque shown is available up to an ambient temperature of 25° C with motor mounted to a 10' x10' x 0.25' aluminum heat sink.

2. Shaft loads are based on L10 bearing life at 3000 rpm and assume force is applied to center of shaft.

3. Peak torque ratings are for the motor only and may be limited by the specific amplifier based on the amplifiers peak current limitations.

Table 2-10. MTR-3T Series Motor Specifications

Specification	Units	3T11-G	3T12-G	3T13-G	3T21-G	3T22-G	3T23-G	3T24-H	3T42-H	3T43-H	3T43-J	3T44-J
Continuous Stall Torque <sup>1</sup>	in-lb [Nm]	2.3 [0.26]	5.3 [0.6]	8 [0.9]	5.6 [0.63]	11.5 [1.3]	17.7 [2.0]	23 [2.6]	33 [3.72]	54 [6.1]	54 [6.1]	72 [8.13]
Peak Torque <sup>3</sup>	in-lb [Nm]	12.4 [1.4]	25.6 [2.9]	38 [4.3]	20.4 [2.3]	41.6 [4.7]	63.7 [7.2]	85 [9.6]	129 [14.6]	192 [21.7]	192 [21.7]	260 [29.4]
Maximum Speed	RPM	6000	6000	6000	9250	7100	4700	4350	4000	2600	4000	3000
Feedback		4096 counts/rev resolver (control transmitter; 0.5 transformation ratio)										
Weight	lb [kg]	2.6 [1.2]	3.3 [1.5]	4.2 [1.9]	3.7 [1.7]	5.0 [2.3]	6.4 [2.9]	7.7 [3.5]	13.6 [6.2]	16.7 [7.6]	16.7 [7.6]	20 [9.0]
Rotor Inertia	in-lb-s <sup>2</sup> x 10 <sup>-4</sup> [kg-m <sup>2</sup> x 10 <sup>-4</sup> ]	1.02 [0.12]	1.64 [0.19]	2.26 [0.26]	1.9 [0.22]	3.4 [0.38]	4.9 [0.55]	6.4 [0.72]	32 [3.6]	46 [5.2]	46 [5.2]	60 [6.8]
Shaft Thrust Load <sup>2</sup>	lb [kg]	N/A	N/A	N/A	17 [7.7]	17 [7.7]	17 [7.7]	17 [7.7]	41.5 [18.9]	41.5 [18.9]	41.5 [18.9]	41.5 [18.9]
Shaft Radial Load <sup>2</sup>	lb [kg]	N/A	N/A	N/A	62 [28.1]	62 [28.1]	62 [28.1]	62 [28.1]	157 [71.5]	157 [71.5]	157 [71.5]	157 [71.5]
Torque Constant	in-lb/A <sub>(rms)</sub> [Nm/A <sub>(rms)</sub> ]	2.4 [0.27]	2.9 [0.32]	2.9 [0.32]	3.3 [0.37]	4.3 [0.49]	6.5 [0.74]	7.0 [0.79]	7.7 [0.87]	11.9 [1.34]	7.5 [0.85]	10.2 [1.15]
Resistance (phase)	Ohms	16.3	6.8	3.9	8.8	4.81	6.1	4.6	3.2	3.9	1.54	1.8
Inductance (phase)	mH	7.1	4.3	2.7	10.5	7.4	10.6	8.9	8.9	13.0	5.3	7.1
Electrical Time Constant	ms	0.43	0.63	0.69	1.19	1.54	1.73	1.93	2.78	3.33	3.44	3.94
Continuous Current	A <sub>(rms)</sub>	0.96	1.88	2.73	1.72	2.65	2.7	3.3	4.7	4.6	7.2	7.2
<b>Optional Brake Data</b>												
Inertia Adder	in-lb-s <sup>2</sup> x 10 <sup>-4</sup> [kg-m <sup>2</sup> x 10 <sup>-4</sup> ]	5.49 [0.62]	2.25 [0.26]	3.81 [0.43]	16.82 [1.9]	6.99 [0.79]	16.82 [1.9]	53.1 [6]	16.82 [1.9]	16.82 [1.9]	16.82 [1.9]	16.82 [1.9]
Weight Adder	lb [kg]	0.4 [0.2]	0.4 [0.2]	0.4 [0.2]	0.4 [0.2]	0.4 [0.2]	0.4 [0.2]	0.4 [0.2]	1.3 [0.6]	1.3 [0.6]	1.3 [0.6]	1.3 [0.6]
Voltage	VDC ± 10%	24	24	24	24	24	24	24	24	24	24	24
Current	A	0.33	0.33	0.33	0.33	0.33	0.33	0.33	0.66	0.66	0.66	0.66
Engage Time	ms	25	25	25	25	25	25	25	20	20	20	20
Release Time	ms	25	25	25	25	25	25	25	30	30	30	30
Torque	in-lb [Nm]	10.6 [1.2]	10.6 [1.2]	10.6 [1.2]	10.6 [1.2]	10.6 [1.2]	10.6 [1.2]	10.6 [1.2]	88.5 [10]	88.5 [10]	88.5 [10]	88.5 [10]
<b>Environmental Data</b>												
Humidity (non-condensing)	RH	98%										
Ambient Temperature (operating)	°C	-20 to 40										
Storage Temperature	°C	-30 to 150										

1. Torque shown is available up to an ambient temperature of 25° C with motor mounted to a 10" x 10" x 0.25" aluminum heat sink.

2. Shaft loads are based on L10 bearing life at 3000 rpm and assume force is applied to center of shaft.

3. Peak torque ratings are for the motor only and may be limited by the specific amplifier based on the amplifiers peak current limitations.

Specification	Units	3T45-H	3T45-I	3T54-H	3T55-H	3T55-I	3T57-H	3T66-H	3T67-G	3T69-G
Continuous Stall Torque <sup>1</sup>	in-lb [Nm]	90.3 [10.2]	90.3 [10.2]	120 [13.5]	151 [17.0]	151 [17.0]	195 [22]	266 [30]	372 [42]	478 [54]
Peak Torque <sup>3</sup>	in-lb [Nm]	326 [36.8]	326 [36.8]	363 [41]	456 [51.5]	456 [51.5]	611 [69]	1009 [114]	1177 [133]	1505 [170]
Maximum Speed	RPM	2350	3300	2700	2150	4300	3050	2000	1700	1300
Feedback	4096 counts/rev resolver (control transmitter; 0.5 transformation ratio)									
Weight	lb [kg]	22.9 [10.4]	22.9 [10.4]	28.6 [13]	33 [15]	33 [15]	41.9 [19]	79.3 [36]	92.5 [42]	54 [119]
Rotor Inertia	in-lb-s <sup>2</sup> x 10 <sup>-4</sup> [kg-m <sup>2</sup> x 10 <sup>-4</sup> ]	74 [8.4]	74 [8.4]	220 [24.9]	271 [30.6]	271 [30.6]	373 [42.1]	833 [94]	965 [109]	1230 [139]
Shaft Thrust Load <sup>2</sup>	lb [kg]	41.5 [18.9]	41.5 [18.9]	31.5 [18.9]	31.5 [18.9]	31.5 [18.9]	31.5 [18.9]	48.3 [21.9]	48.3 [21.9]	48.3 [21.9]
Shaft Radial Load <sup>2</sup>	lb [kg]	157 [71.5]	157 [71.5]	115 [52.3]	115 [52.3]	115 [52.3]	115 [52.3]	200 [45]	200 [45]	200 [45]
Torque Constant	in-lb/A <sub>(rms)</sub> [Nm/A <sub>(rms)</sub> ]	12.9 [1.46]	9.2 [1.04]	11.3 [1.27]	14.2 [1.6]	7.1 [0.8]	10 [1.13]	15.4 [1.74]	18 [2.04]	23.3 [2.63]
Resistance (phase)	Ohms	2.1	1.1	0.8	0.9	0.2	0.3	0.32	0.35	0.41
Inductance (phase)	mH	8.7	4.4	7.1	8.8	2.2	3.1	6.5	7.7	10
Electrical Time Constant	ms	4.1	4	8.9	9.8	11	10.3	20.3	22	24.4
Continuous Current	A <sub>(rms)</sub>	7.1	10	10.6	10.6	21.3	19.5	20.7	20.7	20.6
<b>Optional Brake Data</b>										
Inertia Adder	in-lb-s <sup>2</sup> x 10 <sup>-4</sup> [kg-m <sup>2</sup> x 10 <sup>-4</sup> ]	9.7 [1.1]	9.7 [1.1]	31.9 [3.6]	31.9 [3.6]	31.9 [3.6]	31.9 [3.6]	84.1 [9.5]	84.1 [9.5]	84.1 [9.5]
Weight Adder	lb [kg]	1.3 [0.6]	1.3 [0.6]	3.3 [1.5]	3.3 [1.5]	3.3 [1.5]	3.3 [1.5]	4.8 [2.2]	4.8 [2.2]	4.8 [2.2]
Voltage	VDC± 10%	24	24	24	24	24	24	24	24	24
Current	A	0.48	0.48	0.41	0.41	0.41	0.41	0.73	0.73	0.73
Engage Time	ms	20	20	25	25	25	25	25	25	25
Release Time	ms	30	30	50	50	50	50	75	75	75
Torque	in-lb [Nm]	88.5 [10]	88.5 [10]	15 [16]	159 [16]	159 [16]	159 [16]	354 [40]	354 [40]	354 [40]
<b>Environmental Data</b>										
Humidity (non-condensing)	RH	98%								
Ambient Temperature (operating)	°C	-20 to 40								
Storage Temperature	°C	-30 to 150								

1. Torque shown is available up to an ambient temperature of 25° C with motor mounted to a 10' x10' x 0.25' aluminum heat sink.
2. Shaft loads are based on L10 bearing life at 3000 rpm and assume force is applied to center of shaft.
3. Peak torque ratings are for the motor only and may be limited by the specific amplifier based on the amplifiers peak current limitations.

## 2.2 Motor Speed/Torque Curves

The curves below illustrate the relationship between motor speed and output torque when used with the specified S2K amplifier model. The motor can operate continuously at any combination of speed and torque within the prescribed continuous operating zone. Curves are shown for a 230 Vac nominal supply.

### 2.2.1 S-Series Servo Motor / Controller Curves

The curves below illustrate the relationship between motor speed and output torque when used with the specified S2K series model. The motor can operate continuously at any combination of speed and torque within the prescribed continuous operating zone. Curves are shown for a 230 Vac nominal supply.

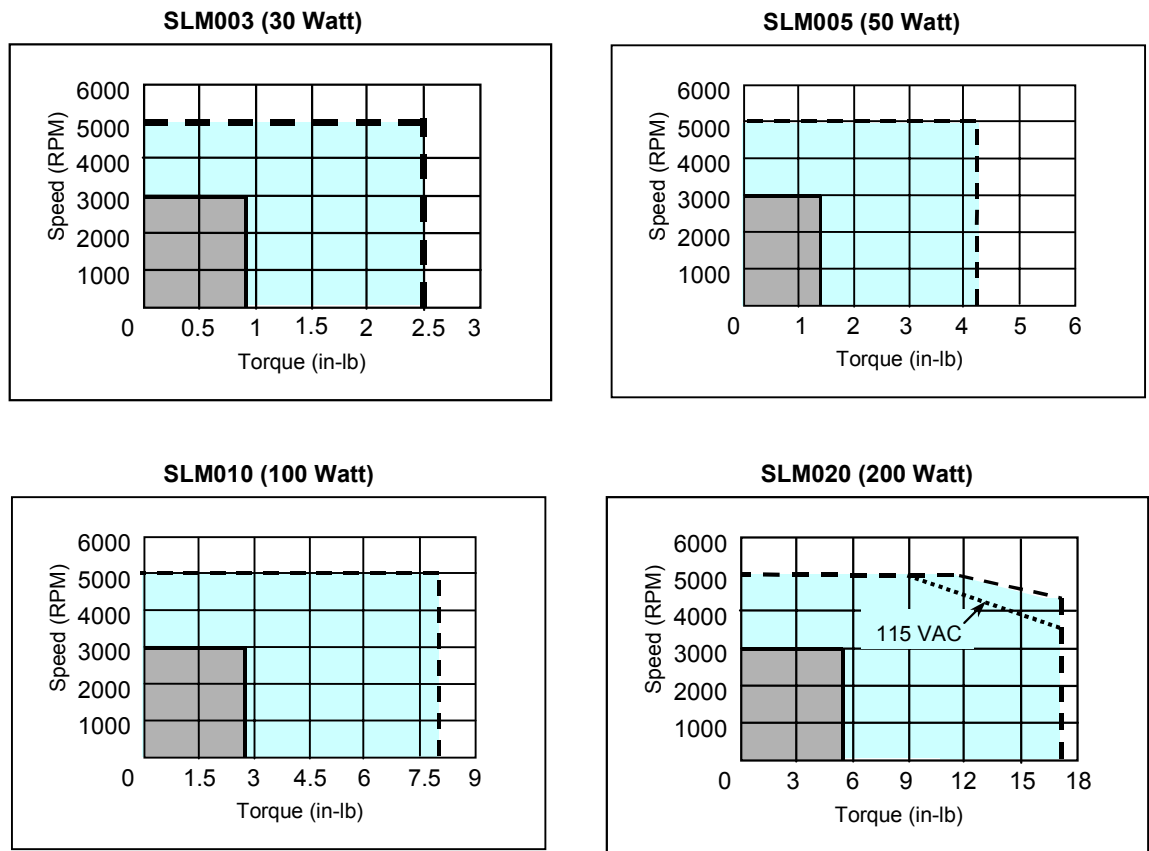

**SLM040 (400 Watt)**

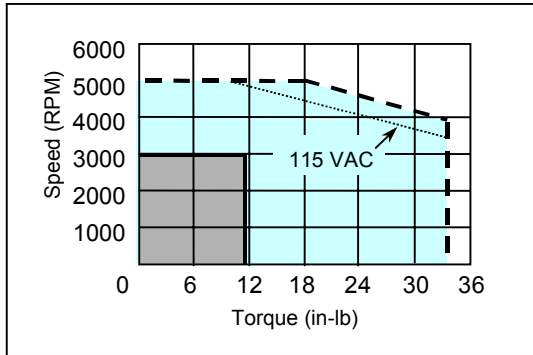

**SLM075 (750 Watt)**

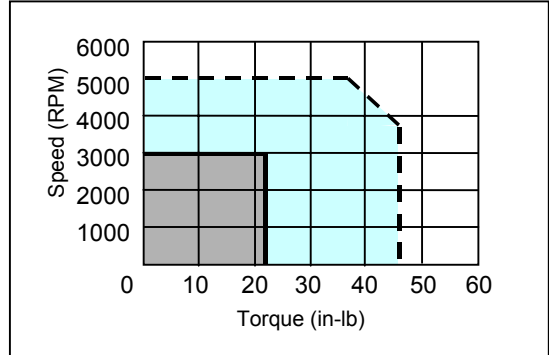

**SDM100 (1000 Watt)**

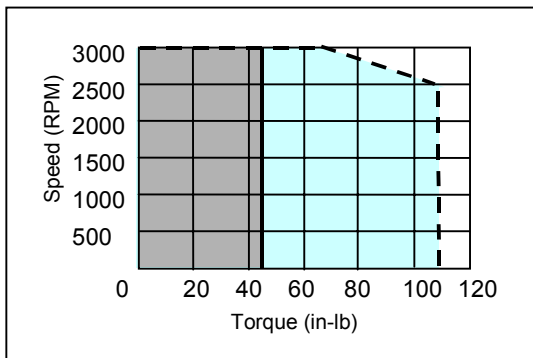

**SLM100 (1000 Watt)**

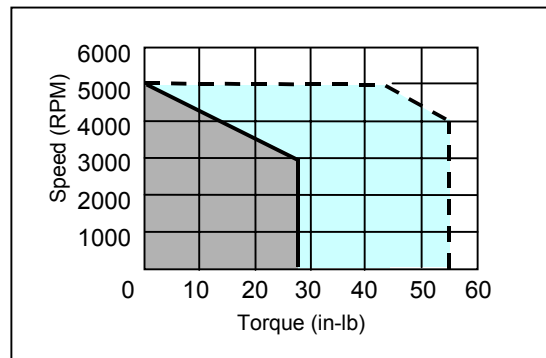

**SDM250 (2500 Watt)**

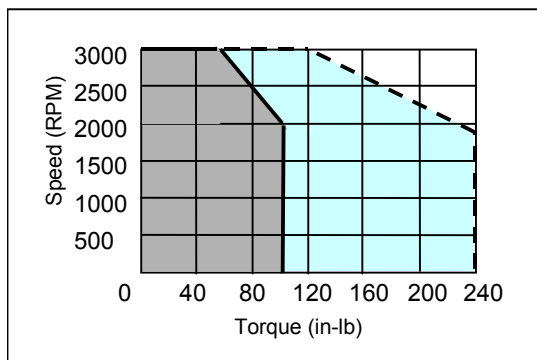

**SLM250 (2500 Watt)**

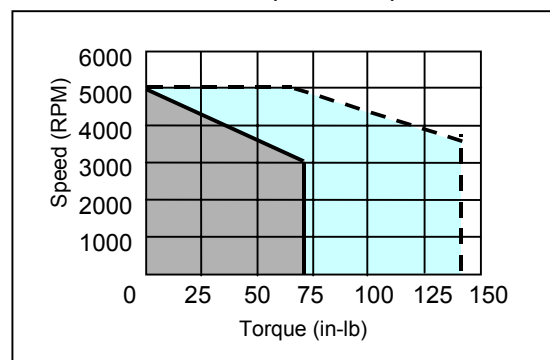

**SLM350 (3500 Watt)**

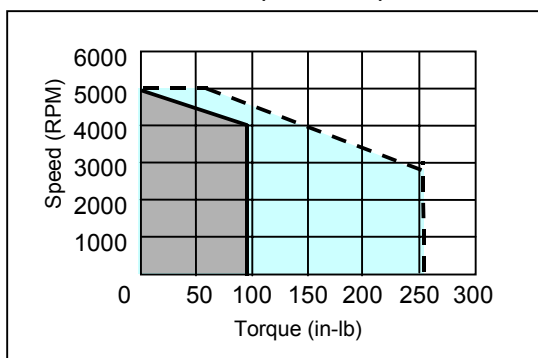

**SDM500 (5000 Watt)**

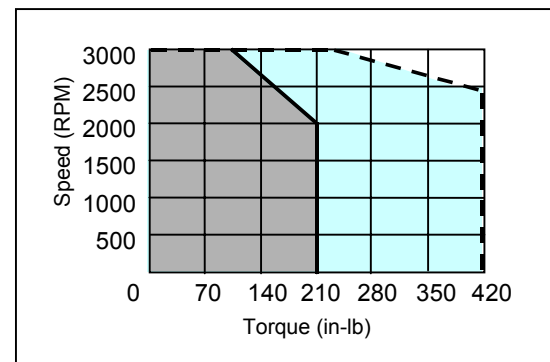

---

**Note:** Continuous torque available for each motor model depends on the ambient temperature. These curves depict the maximum continuous torque available for each model up to the following ambient temperatures:

- SLM003, SLM100, SDM100, SDM250 & SGM450 = 40 °C
- SLM005, SLM250, SLM500 = 20°C
- SLM350 = 25 °C
- SDM500 = 35°C

Higher ambient temperatures require motor derating as shown in the temperature derating curves in Section 2.3.

## 2.3 S-Series Motor Derating Based on Ambient Temperature

The S-Series servo motors produce the continuous torque shown in the speed/torque curves (Section 0), up to certain ambient temperature limits depending on the motor model. The following curves depict the continuous torque derating required for operation in ambient temperatures above this rating and up to the 40 °C limit. The intermittent torque available from each motor does not need to be derated.

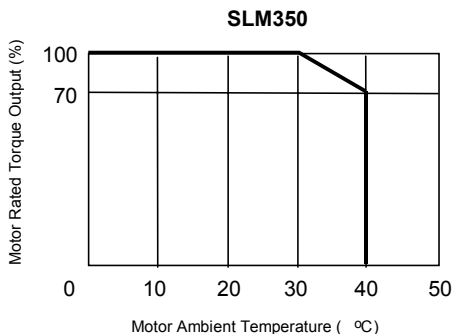
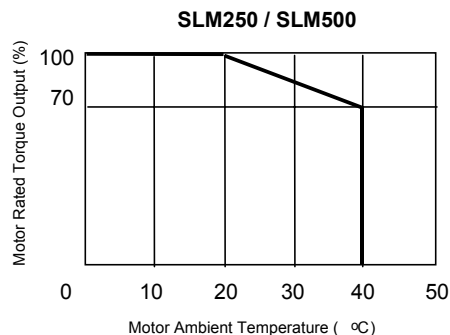
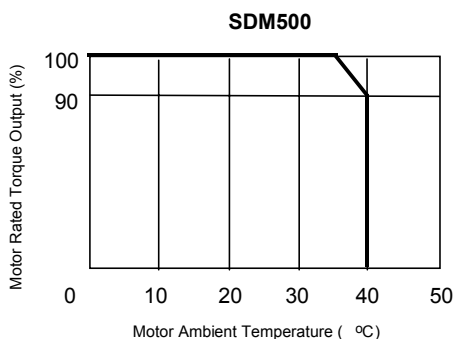
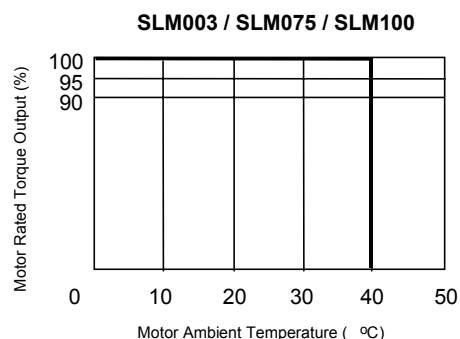
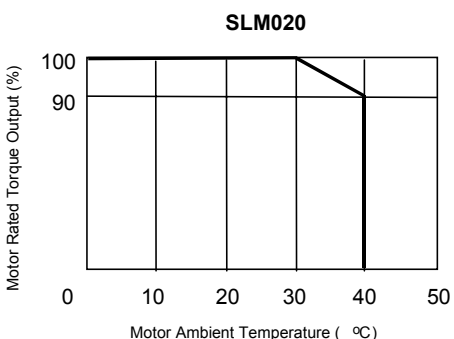
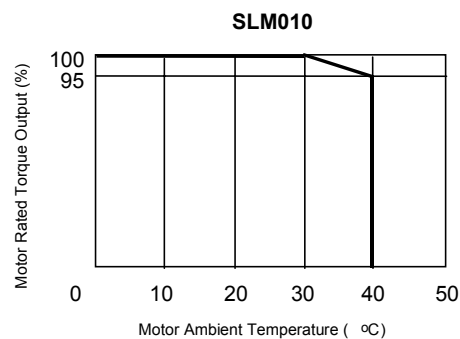
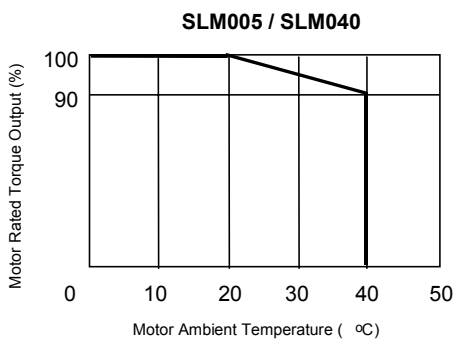

## 2.4 Servo Motor Sealing

The S-Series and MTR-Series servo motors are designed to comply with an IP65 protection rating excluding the cable connector and shaft. The 1-5 kW rated S-Series motors include a shaft oil seal as a standard feature while the 30-750 W S-Series motors do not include a shaft seal. All MTR-Series motors except 3T40, 3T50 and 3T60 models include a shaft oil seal as standard. Adequate precautions should be taken when mounting the motors to ensure proper protection against excessive exposure to fluids and spray.

## 2.5 Servo Motor Holding Brakes

As an option the servo motors are available with an integral 24 VDC parking brake. The brakes are designed for failsafe operation and must be energized to release the brake.

### Caution

**The brake should only be used to hold motor position once the axis is stopped. Using the brake to stop a moving load may result in damage or premature failure of the brake mechanism. Use an external mechanical brake to stop moving loads during an emergency stop or loss of power.**

The brakes require a finite time to engage and release the load as shown in the brake specifications in Table 2-7. These times must be considered in the brake sequencing logic when employing brake motors on vertical axes to prevent the load from falling. The amplifier must remain enabled until the brake is fully engaged or the load will not be adequately restrained.

The brake power supply is the user's responsibility and must comply with the brake specifications shown in Tables 2-7 to 2-10. GE Fanuc offers a 24VDC, 5-amp DIN-rail mounted power supply (IC690PWR024) that may be appropriate as a brake supply on multi-axis systems. A panel mounting conversion kit is also available (IC690PAC001). Brake power cables are available from GE Fanuc in several pre-finished lengths as shown in Table 3-9.

## 2.6 Motor Mounting

The S-Series servo motors with ratings up to 1000 Watt (SLM models) are designed with standard NEMA shaft and flange sizes as shown in Table 2-11 to facilitate mounting to readily available gear reducers and actuators. SDM, SGM and all SLM models larger than 1kW have metric mounting configurations. For dimensional information on these motors (including mounting dimensions), please see the mechanical drawings in Chapter 3.

**Table 2-11 Mounting Configurations for Servo Motors**

Motor Mounting	Motor Mounting					
	NEMA 23	NEMA 34	NEMA 42	NEMA 56C	Metric	English
SLM003	X					
SLM005	X					
SLM010	X					
SLM020		X				
SLM040		X				
SLM075		X				
SLM100			X			
SDM100					X	
SLM250					X	
SDM250					X	
SLM350					X	
SLM500					X	
SDM500					X	
3N2x	X					
3N3x		X				
3S2x	X					
3S3x		X				
3S4x				X		X
3S6x						X
3S8x						X
3T1x					X	
3T2x					X	
3T4x					X	
3T5x					X	
3T6X					X	

\* The SLM075 (750 Watt) model has an oversized shaft diameter for the NEMA 34 frame size. This is required because the torque rating of this motor exceeds the capacity of the standard NEMA 34 shaft size. This condition is typical of high performance brushless servo motors that produce high peak torque relative to their frame size. For details about motor installation and dimensions, see Chapter 3.

## 3.1 Heat Load and Cooling

The heat load of the S2K Series amplifiers is dependent on the model as shown below:

Model SSD104: Heat Load = 25 watts + (35 \* duty\_cycle) watts or 60 watts max.  
Model SSD107: Heat Load = 35 watts + (65 \* duty\_cycle) watts or 100 watts max.  
Model SSD216: Heat Load = 50 watts + (150 \* duty\_cycle) watts or 200 watts max.  
Model SSD228: Heat Load = 60 watts + (280 \* duty\_cycle) watts or 340 watts max.  
Model SSD407: Heat Load = 35 watts + (65 \* duty\_cycle) watts or 100 watts max.  
Model SSD420: Heat Load = 60 watts + (250 \* duty\_cycle) watts or 310 watts max.

Duty cycle is defined as the percent of time the amplifier is at full rated output divided by the total cycle time. The SSD104 and SSD107 models are designed to operate at full rated current with only natural convection cooling at ambient temperatures up to 50 degrees C. The remaining models have built-in fan cooling.

The amplifiers must be installed vertically for effective cooling. Allow a minimum clearance of 3 inches (76 mm) above and below the unit. A minimum of 2 to 3 inches (50 to 75 mm) clearance is also recommended on the right and left sides of the unit where possible.

## 3.2 Amplifier Mounting Guidelines and Environmental Conditions

It is the user's responsibility to install the components in a suitable location. The S2K amplifier must be installed in a location that satisfies the following environmental conditions:

1. **Atmosphere:** The circuitry must not be exposed to any corrosive or conductive contaminants.
2. **Ambient temperature:** 0°C to +50°C (operating)  
-40°C to 80°C (storage)

Install the amplifier into ambient temperature conditions within the range of 0° C to +50° C. If the temperature exceeds this range, it may cause malfunction or damage to the amplifier. The amplifier heat sink and motor generate high temperatures. If the amplifier is housed in an enclosed control cabinet this heat load must be considered when evaluating the enclosure cooling requirements (see Section 3.1-*Heat Load and Cooling* for details on amplifier losses). Use heat exchangers or cooling devices to maintain an ambient temperature of 50° C or less.

3. **Humidity:** 95% relative humidity or less (non-condensing)
4. **Altitude:** No more than 1000m (3300 ft) above sea level for full rating. Contact GE Fanuc Applications Engineering for derating at higher elevations.
5. **Ventilation:** This amplifier is designed for vertical installation to ensure proper cooling. Install the amplifier with sufficient space for ventilation. Avoid mounting wireways and other adjacent components too close to the heat sink, top or bottom of the amplifier.
6. **Location:** Keep the following location guidelines in mind when selecting a site for the amplifier:
  - Do not install in places with high temperature, high humidity, dust, dirt, conductive powder or particulate, combustible gasses, or metal chips.
  - Avoid places exposed to direct sunlight.
  - Mount only to noncombustible materials such as metal.
  - Do not stand/step on or put heavy articles on the amplifier or motor.
  - The amplifier housing is not a waterproof enclosure. Do not use outdoors or in any unprotected environment. The amplifiers are designed with "open" construction and must be installed in an enclosure that protects personnel from contact with wiring terminals and provides a pollution degree 2 environment.
  - Avoid locations where there is exposure to radiation such as microwave, ultraviolet, laser light or X-rays.
  - Do not apply excessive stress, put heavy articles on, or pinch the cables.
  - Do not install the amplifier near heating elements such as cabinet heaters or large wire wound resistors. When such installation is unavoidable, provide a thermal shield between the servo amplifier and the heating elements.
  - Mount amplifier and other heat producing components higher in the enclosure to avoid overheating other sensitive electronics installed in the same cabinet.

### 3.3 Installing the Amplifier

The S2K Series amplifiers are designed for panel mounting in electrical enclosures designed for industrial applications. Enclosure cooling or ventilation must be adequate to maintain the ambient temperature to within the component's specifications. Mount amplifiers vertically for proper cooling.

1. Firmly install the amplifier with screws and bolts without applying stress such as bending and twisting to the amplifier main unit.
2. Allow reasonable mounting clearance between adjacent units to ensure proper ventilation.

#### Caution

**Since a misuse of the amplifier may lead to improper operation, or may damage the amplifier, carefully read the following cautions and warnings:**

- Be sure to ground the amplifier properly using the ground terminals on the front of the amplifier. Proper grounding includes conforming to applicable national and local electrical codes.
- Do not apply higher than rated voltage to the power input terminals (L1, L2 and L3)

- Do not apply the main input power to terminals other than terminals L1, L2 and L3 or damage will occur. Refer to Section 3.6 for wiring information.
- The power supply uses a capacitor filter. When you turn on power, a high charging current flows and you may see a large voltage drop. We recommend that you install line reactors to limit the charging current if this presents problems with other equipment on the machine.
- Do not perform a dielectric strength test or megger test on the amplifier or damage may occur. (When you perform a dielectric strength test or megger test to an external circuit, please disconnect all terminals to the amplifier so that no test voltage is applied to the amplifier.)
- Do not operate the amplifier under overload conditions (such as continuous overcurrent operation).
- If you use a ground fault breaker, use one rated for "Inverter," to withstand high frequency leakage current.
- Use the motor and amplifiers only in the designated combinations (Table 1-1).
- When transporting, use caution to prevent damage to the S2K components. Do not grasp the cables when carrying the amplifier.

## 3.4 Installing the Motor

The S-Series and MTR-Series servo motors are designed for either vertical or horizontal mounting and have a protection rating of IP65 (not including the connectors and shaft). The motors should be mounted in a location where the environmental conditions are within the specifications stated in Chapter 2. Use the following guidelines when mounting the motors:

- Observe the shaft radial and thrust load limits. Loads exceeding these limits will cause premature failure of the motor. Excessive belt tension could cause bearing or shaft failure.
- Be sure to ground the motor using the ground wire in the motor power cable.
- Ensure that the motor cables are free from excessive stress, stretching, pinching or bending.
- To avoid damage, do not carry a motor by holding the cables or shaft.
- Do not apply excessive axial force or impact loads when installing the motor coupling or shaft pulley or the encoder may be damaged. See axial load limit ratings in Chapter 2.
- Install the motor in a location free from corrosive contaminants, dust, excessive water spray, or combustible gas.
- The shaft of the S-Series motors are treated with grease (Shell Oil Alvania No. 2) for corrosion protection during storage. Consider the effect of the grease on any plastic parts that are mated with the shaft.
- The optional motor brake should be used for holding stationary loads only. Do not use this brake to stop a moving load or reduced life or damage to the brake may occur. Apply this brake only after the motor is stopped.

## 3.5 Mounting Dimensions

### 3.5.1 Amplifier Dimensions

Code in Diagram	Feature	Units	SSD104	SSD107	SSD407
N/A	Weight	lb (kg)	3.6 (1.64)	5.5 (2.5)	6.0 (2.7)
A	Depth	inch (mm)	6.05 (153.7)	8.15 (207)	8.15 (207)
B	Total Width	inch (mm)	3.20 (81.3)	3.45 (87.6)	4.34 (110.2)
C	Height	inch (mm)	8.50 (215.9)	8.50 (215.9)	8.50 (215.9)
D	Position Feedback Connector (includes mating connector supplied on GE Fanuc cable)	inch (mm)	1.26 (32)	1.26 (32)	1.26 (32)

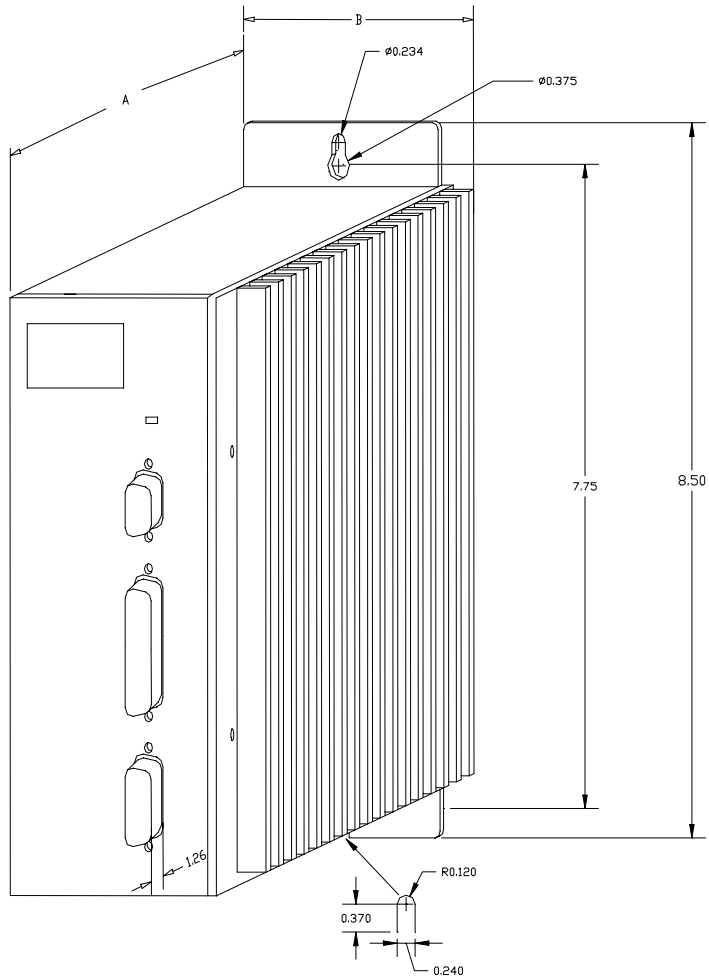
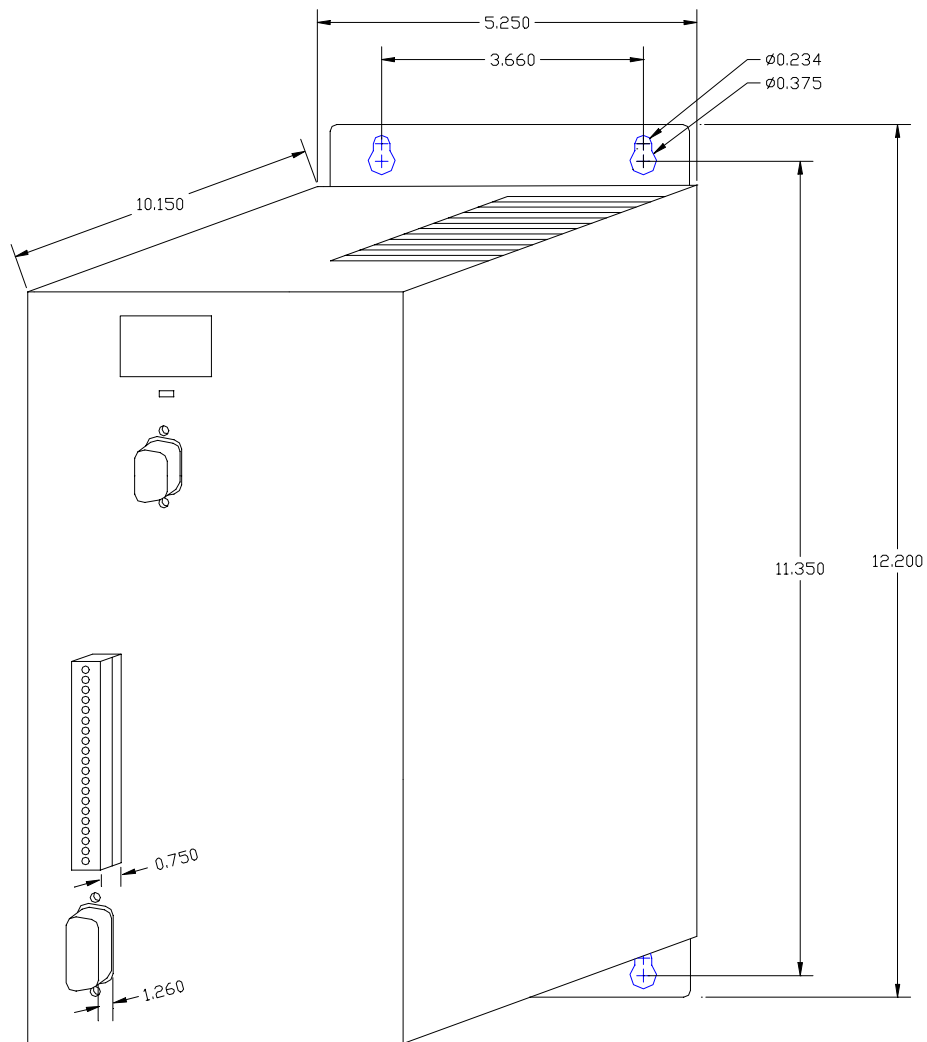

Figure 3-1. SSD104, SSD107 and SSD407 S2K Series Amplifier Dimensions and Weight

Code in Diagram	Feature	Units	SSD216 SSD228 SSD420
N/A	Weight	lb (kg)	14 (6.4)
A	Depth	inch (mm)	10.15 (258)
B	Total Width	inch (mm)	5.25 (133.4)
C	Height	inch (mm)	12.20 (309.9)
D	Position Feedback Connector Depth (includes mating connector supplied on GE Fanuc cable)	inch (mm)	1.26 (32)
E	User I/O Connector Depth	inch (mm)	0.75 (19)



Dimensions are shown in inches.

Figure 3-2. SSD216, SSD228 and SSD420 S2K Series Amplifier Dimensions and Weight

### 3.5.2 S-Series Servo Motor Dimensions

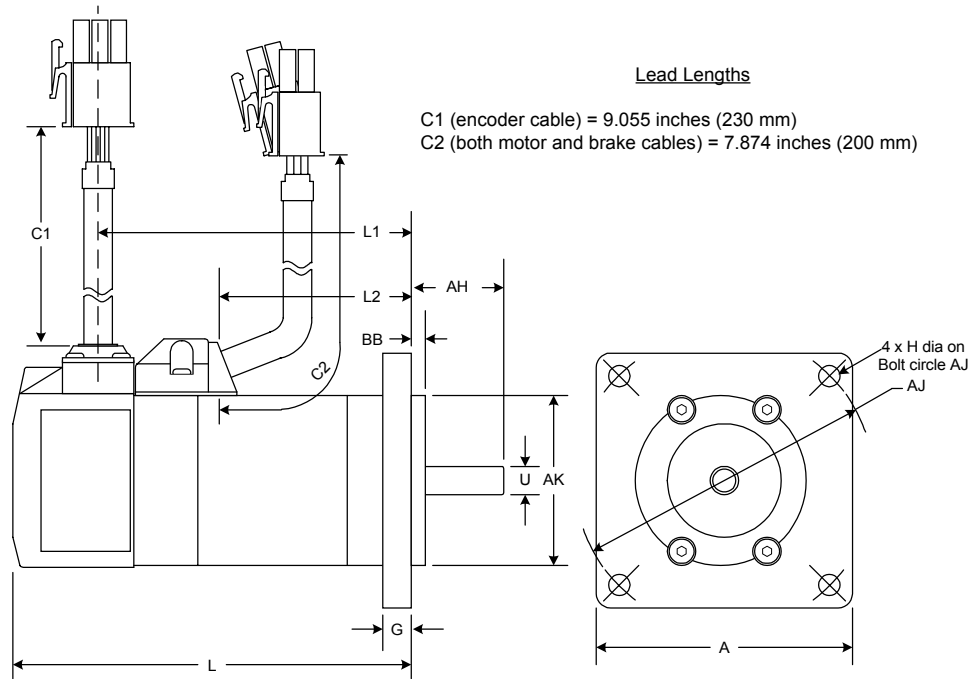

Model	Units	A	AH	AJ	AK	BB	G
SLM003 (30 Watts)	inches	2.27 ± 0.024	0.7874 ± 0.028	2.625 ± 0.024	1.502 <sup>+0</sup> <sub>-0.001</sub>	0.118 ± 0.008	0.236 ± 0.012
	mm	57.658 ± 0.6	20 ± 0.7	66.675 ± 0.6	38.1508 <sup>+0</sup> <sub>-0.025</sub>	3 ± 0.2	6 ± 0.3
SLM005 (50 Watts)	inches	2.27 ± 0.024	0.7874 ± 0.028	2.625 ± 0.024	1.502 <sup>+0</sup> <sub>-0.001</sub>	0.118 ± 0.008	0.236 ± 0.012
	mm	57.658 ± 0.6	20 ± 0.7	66.675 ± 0.6	38.1508 <sup>+0</sup> <sub>-0.025</sub>	3 ± 0.2	6 ± 0.3
SLM010 (100 Watts)	inches	2.27 ± 0.024	0.7874 ± 0.028	2.625 ± 0.024	1.502 <sup>+0</sup> <sub>-0.001</sub>	0.118 ± 0.008	0.236 ± 0.012
	mm	57.658 ± 0.6	20 ± 0.7	66.675 ± 0.6	38.1508 <sup>+0</sup> <sub>-0.025</sub>	3 ± 0.2	6 ± 0.3

Model	Units	H	U	L	L (With Brake)	L1	L1 (With Brake)	L2 (With or Without Brake)
SLM003 (30 Watts)	inches	0.1968 ± 0.010	0.25 <sup>+0</sup> <sub>-0.0004</sub>	2.559	3.819	1.772	3.031	0.709
	mm	5 ± 0.25	6.35 <sup>+0</sup> <sub>-0.009</sub>	65	97	45	77	18
SLM005 (50 Watts)	inches	0.1968 ± 0.010	0.25 <sup>+0</sup> <sub>-0.0004</sub>	2.874	4.134	2.087	3.346	1.024
	mm	5 ± 0.25	6.35 <sup>+0</sup> <sub>-0.009</sub>	73	105	53	85	26
SLM010 (100 Watts)	inches	0.1968 ± 0.010	0.25 <sup>+0</sup> <sub>-0.0004</sub>	4.055	5.315	3.268	4.528	2.205
	mm	5 ± 0.25	6.35 <sup>+0</sup> <sub>-0.009</sub>	103	135	83	115	56

Figure 3-3. Dimensions for 30-100 Watt SL Series Motors

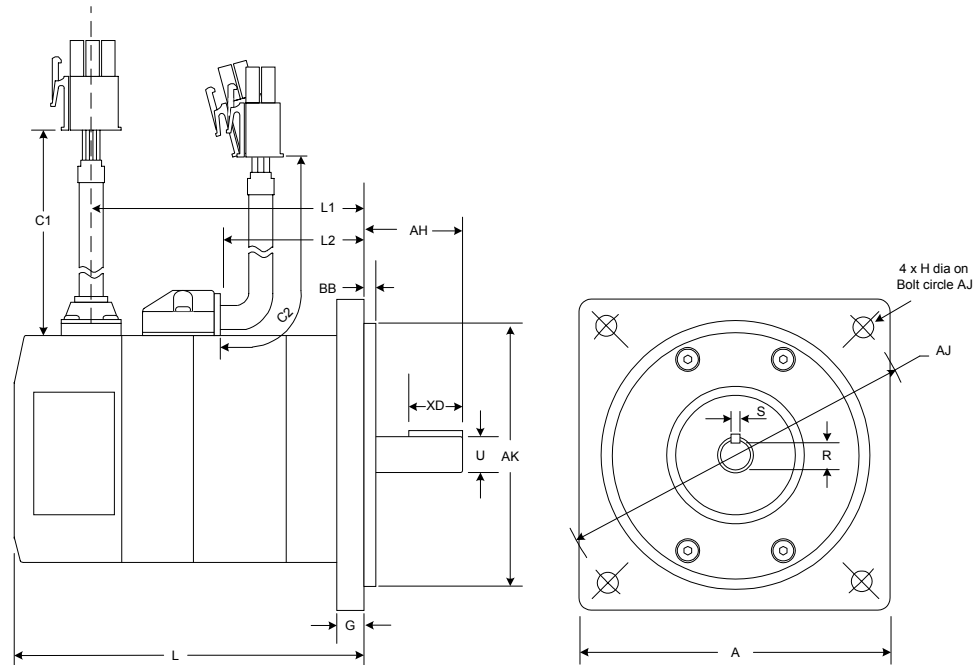

Model	Units	A	AH	AJ	AK	BB	G	H
SLM020 (200 Watt)	inch	3.42 ± 0.024	1.181 ± 0.028	3.875 ± 0.024	2.877 <sup>+0</sup> <sub>-0.0012</sub>	0.118 ± 0.008	0.315 ± 0.012	0.2165 ± 0.010
	mm	86.868 ± 0.6	30 ± 0.7	98.425 ± 0.6	73.0758 <sup>+0</sup> <sub>-0.030</sub>	3 ± 0.2	8 ± 0.3	5.5 ± 0.25

Model	Units	C1	C2	L1	L1 (With Brake)	L2 (With or Without Brake)
SLM020 (200 Watt)	inch	8.662	7.874	2.854	4.154	1.535
	mm	220	200	72.5	105.5	39

Model	Units	U	L	L (With Brake)	R	S	XD
SLM020 (200 Watt)	inch	0.375 <sup>+0</sup> <sub>-0.0004</sub>	3.701	5.000	0.3018 <sup>+0</sup> <sub>-0.015</sub>	0.125 <sup>+0</sup> <sub>-0.002</sub>	0.75 <sup>+0</sup> <sub>-0.016</sub>
	mm	9.5250 <sup>+0</sup> <sub>-0.009</sub>	94	127	7.666 <sup>+0</sup> <sub>-0.381</sub>	3.175 <sup>+0</sup> <sub>-0.051</sub>	19.050 <sup>+0</sup> <sub>-0.4</sub>

Figure 3-4. Dimensions for 200 Watt S-Series Servo Motor

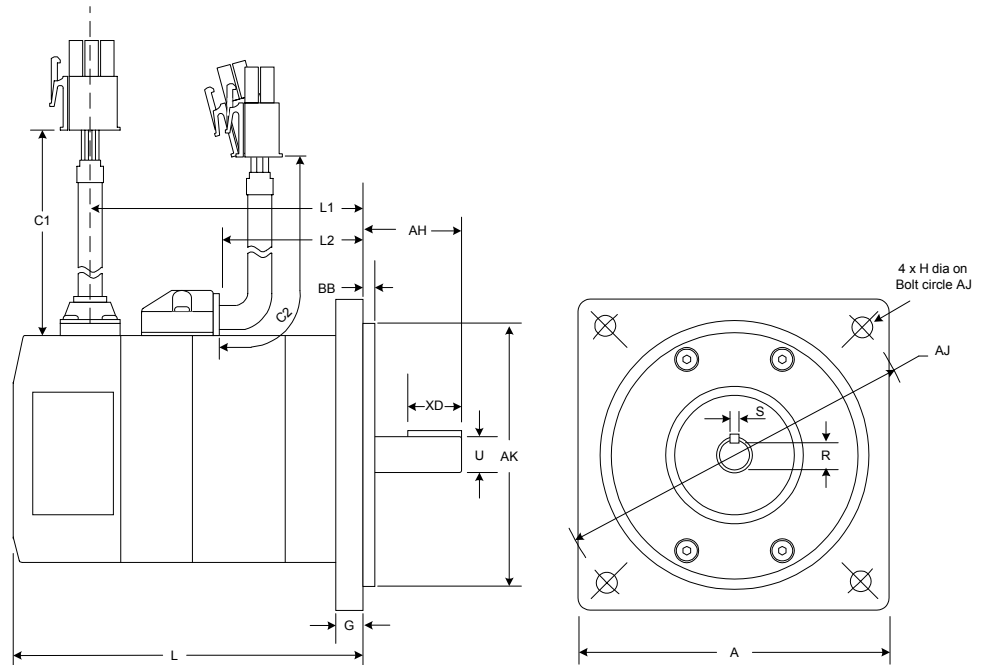

Model	Units	A	AH	AJ	AK	BB	G	H
SLM040 (400 Watt)	inch	3.42 ± 0.024	1.181 ± 0.028	3.875 ± 0.024	2.877 <sup>+0</sup> <sub>-0.0012</sub>	0.118 ± 0.008	0.315 ± 0.012	0.2165 ± 0.010
	mm	86.868 ± 0.6	30 ± 0.7	98.425 ± 0.6	73.0758 <sup>+0</sup> <sub>-0.030</sub>	3 ± 0.2	8 ± 0.3	5.5 ± 0.25

Model	Units	C1	C2	L1	L1 (With Brake)	L2 (With or Without Brake)
SLM040 (400 Watt)	inch	8.662	7.874	4.016	5.315	2.697
	mm	220	200	102	135	68.5

Model	Units	U	L (Without Brake)	L (With Brake)	R	S	XD
SLM040 (400 Watt)	inch	0.375 <sup>+0</sup> <sub>-0.0004</sub>	4.862	6.161	0.3018 <sup>+0</sup> <sub>-0.015</sub>	0.125 <sup>+0</sup> <sub>-0.002</sub>	0.75 <sup>+0</sup> <sub>-0.016</sub>
	mm	9.5250 <sup>+0</sup> <sub>-0.009</sub>	123.5	156.5	7.666 <sup>+0</sup> <sub>-0.381</sub>	3.175 <sup>+0</sup> <sub>-0.051</sub>	19.050 <sup>+0</sup> <sub>-0.4</sub>

Figure 3-5. Dimensions for 400 Watt S-Series Servo Motor

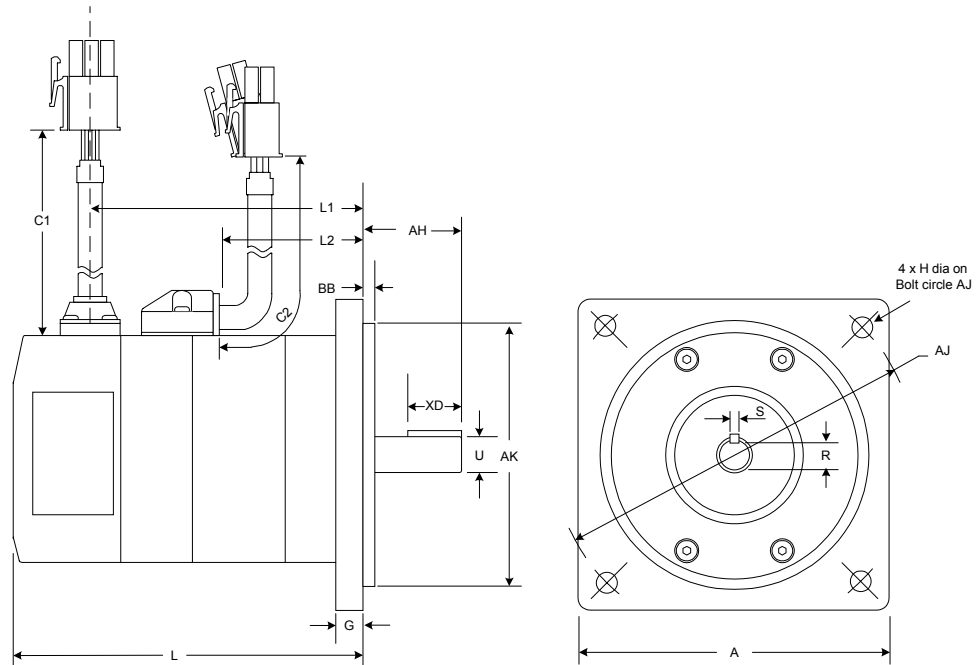

Model	Units	A	AH	AJ	AK	BB	G	H
SLM075 (750 Watt)	inch	3.42 ± 0.024	1.181 ± 0.028	3.875 ± 0.024	2.877 <sup>+0</sup> <sub>-0.0012</sub>	0.118 ± 0.008	0.315 ± 0.012	0.2165 ± 0.010
	mm	86.868 ± 0.6	30 ± 0.7	98.425 ± 0.6	73.0758 <sup>+0</sup> <sub>-0.030</sub>	3 ± 0.2	8 ± 0.3	5.5 ± 0.25

Model	Units	C1	C2	L1	L1 (With Brake)	L2 (With or Without Brake)
SLM075 (750 Watt)	inch	8.662	7.874	4.764	6.142	3.346
	mm	220	200	121	156	85

Model	Units	U	L (Without Brake)	L (With Brake)	R	S	XD
SLM075 (750 Watt)	inch	0.625 <sup>+0</sup> <sub>-0.0004</sub>	5.610	6.988	0.5165 <sup>+0</sup> <sub>-0.015</sub>	0.1885 <sup>+0</sup> <sub>-0.002</sub>	0.952 <sup>+0</sup> <sub>-0.016</sub>
	mm	15.875 <sup>+0</sup> <sub>-0.011</sub>	142.5	177.5	13.120 <sup>+0</sup> <sub>-0.383</sub>	4.788 <sup>+0</sup> <sub>-0.051</sub>	24.200 <sup>+0</sup> <sub>-0.4</sub>

Figure 3-6. Dimensions for 750 Watt S-Series Servo Motor

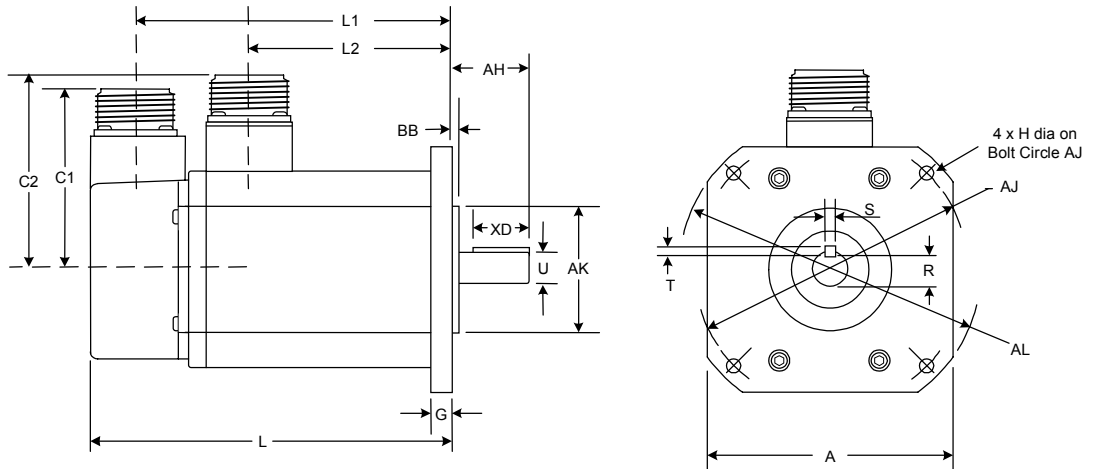

Note: Shaft end play (axial) = 0.0118" (0.3 mm) or less

Model	Units	A	AH	AJ	AK	AL	BB	G
SLM100	inch	4.38	1.378	4.95	2.188 <sup>+0</sup> <sub>-0.004</sub>	5.512	0.118	0.394
	mm	111.25	35	125.73	55.575 <sup>+0</sup> <sub>-0.1</sub>	140	3	10
SDM100	mm	130	55	145	100 <sup>+0</sup> <sub>-0.035</sub>	165	6	12
SLM250	mm	100	55	115	95 <sup>+0</sup> <sub>-0.035</sub>	135	3	10
SDM250	mm	130	65	145	100 <sup>+0</sup> <sub>-0.035</sub>	165	6	12

Model	Units	C1	C2	L1	L1 (W/Brake)	L2	L2 (W/Brake)
SLM100	inch	3.31	3.62	6.012	7.087	3.858	4.843
	mm	84	92	155	180	98	123
SDM100	mm	84	112	130	155	75	100
SLM250	mm	84	97	207	232	153	178
SDM250	mm	84	112	205	230	150	175

Model	Units	H	U	L	L (W/Brake)	R	S	T	XD
SLM100	inch	0.2600	0.625 <sup>+0</sup> <sub>-0.0005</sub>	6.890	7.874	0.5165 <sup>+0</sup> <sub>-0.015</sub>	0.1885 <sup>+0</sup> <sub>-0.002</sub>	0.1885	1.000
	mm	6.6	15.875 <sup>+0</sup> <sub>-0.013</sub>	175	200	13.120 <sup>+0</sup> <sub>-0.383</sub>	4.788 <sup>+0</sup> <sub>-0.051</sub>	4.788	25.4
SDM100	mm	9	22 <sup>+0</sup> <sub>-0.013</sub>	150	175	18	8 <sup>+0</sup> <sub>-0.036</sub>	7	41
SLM250	mm	9	19 <sup>+0</sup> <sub>-0.013</sub>	227	252	15.5	6 <sup>+0</sup> <sub>-0.036</sub>	6	42
SDM250	mm	9	24 <sup>+0</sup> <sub>-0.013</sub>	225	250	20	8 <sup>+0</sup> <sub>-0.036</sub>	7	41

Figure 3-7. Dimensions for 1000 Watt and 2500 W S-Series Servo Motors

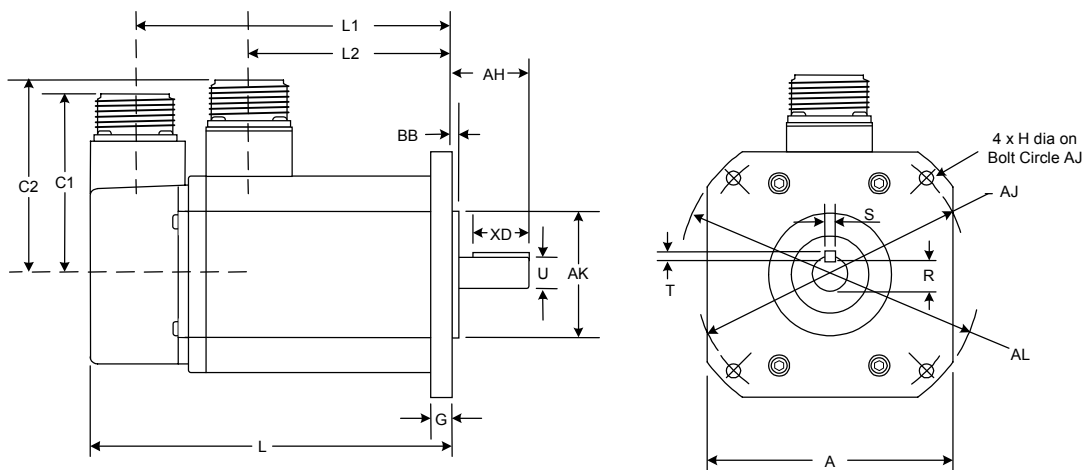

Note: Shaft end play (axial) = 0.0118" (0.3 mm) or less

Model	Units	A	AH	AJ	AK	AL	BB	G
SLM350	mm	120	55	130/145*	110 <sup>+0</sup> <sub>-0.035</sub>	162	3	12
SLM500	mm	130	65	145	110 <sup>+0</sup> <sub>-0.035</sub>	165	6	12
SDM500	mm	176	70	200	114.3 <sup>+0</sup> <sub>-0.035</sub>	233	3.2	18
SGM450	mm	176	113	200	114.3 <sup>+0</sup> <sub>-0.035</sub>	233	3.2	24

Model	Units	C1	C2	L1	L1 (W/Brake)	L2	L2 (W/Brake)
SLM350	mm	84	111	214	239	160	185
SLM500	mm	84	119	257	282	202	227
SDM500	mm	84	143	202	227	145	170
SGM450	mm	84	143	269	317.5	212	260.5

Model	Units	H	U	L	L (W/Brake)	R	S	T	XD
SLM350	mm	9	22 <sup>+0</sup> <sub>-0.013</sub>	234	259	18	8 <sup>+0</sup> <sub>-0.036</sub>	7	41
SLM500	mm	9	24 <sup>+0</sup> <sub>-0.013</sub>	277	302	20	8 <sup>+0</sup> <sub>-0.036</sub>	7	51
SDM500	mm	13.5	35 <sup>+0</sup> <sub>-0.016</sub>	222	247	30	10 <sup>+0</sup> <sub>-0.036</sub>	7	50
SGM450	mm	13.5	42 <sup>+0</sup> <sub>-0.016</sub>	289	337.5	37 <sup>+0</sup> <sub>-0.2</sub>	12 <sup>+0</sup> <sub>-0.043</sub>	8	90

Figure 3-8. Dimensions for 4500 Watt and 5000 W S-Series Servo Motors

### 3.5.3 MTR-3T Series Servo Motor Dimensions

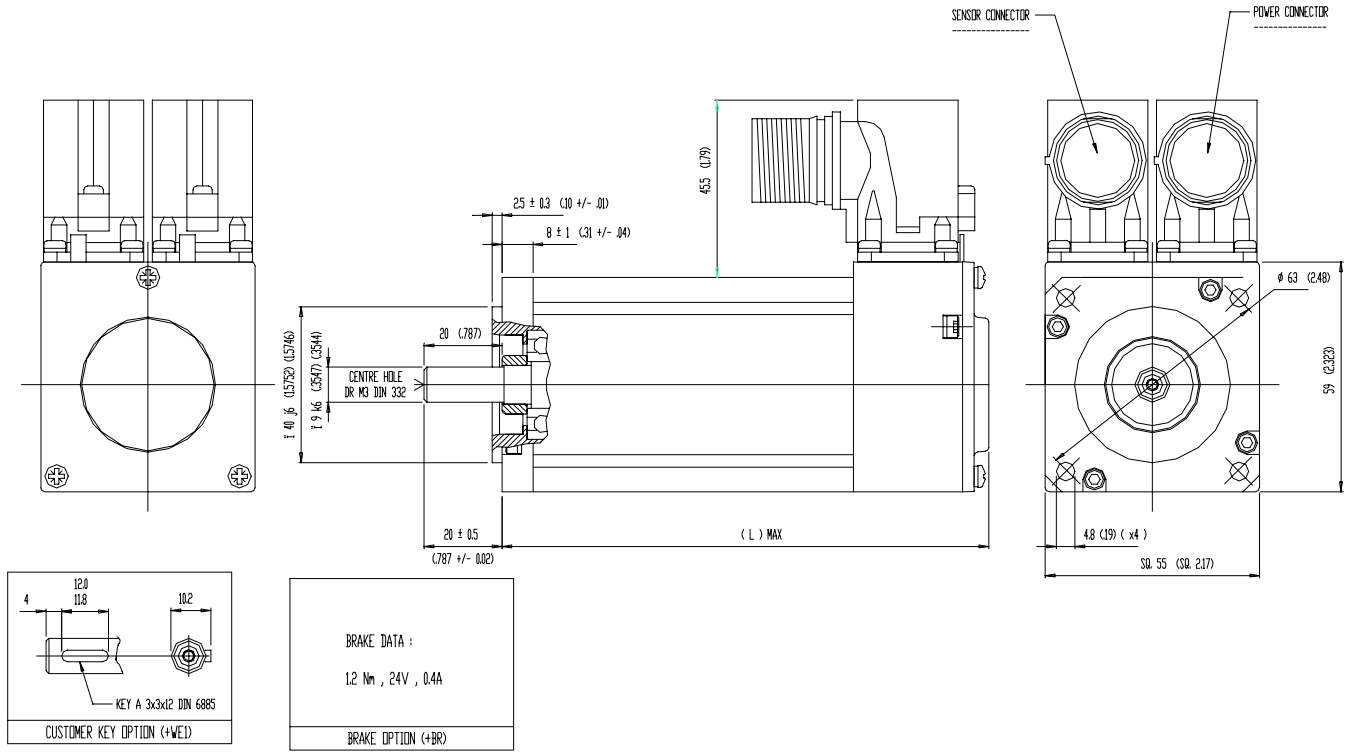

Motor	L Max	
	mm	Inches
3T11	125	4.921
3T12	150	5.906
3T13	175	6.890

Figure 3-9. Dimensions for MTR-3T1x-Series Servo Motors

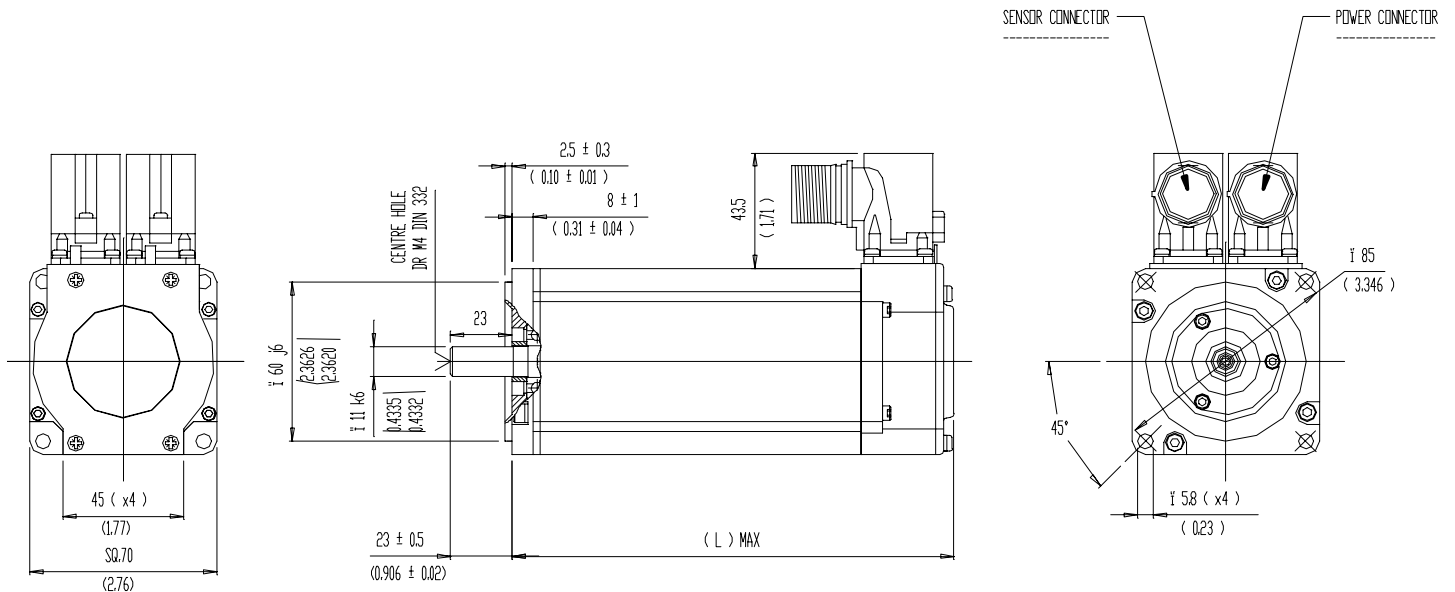

Motor	L Max	
	mm	Inches
3T21	143	5.6
3T22	168	6.6
3T23	193	7.6
3T24	218	8.6

Figure 3-10. Dimensions for MTR-3T2x-Series Servo Motors

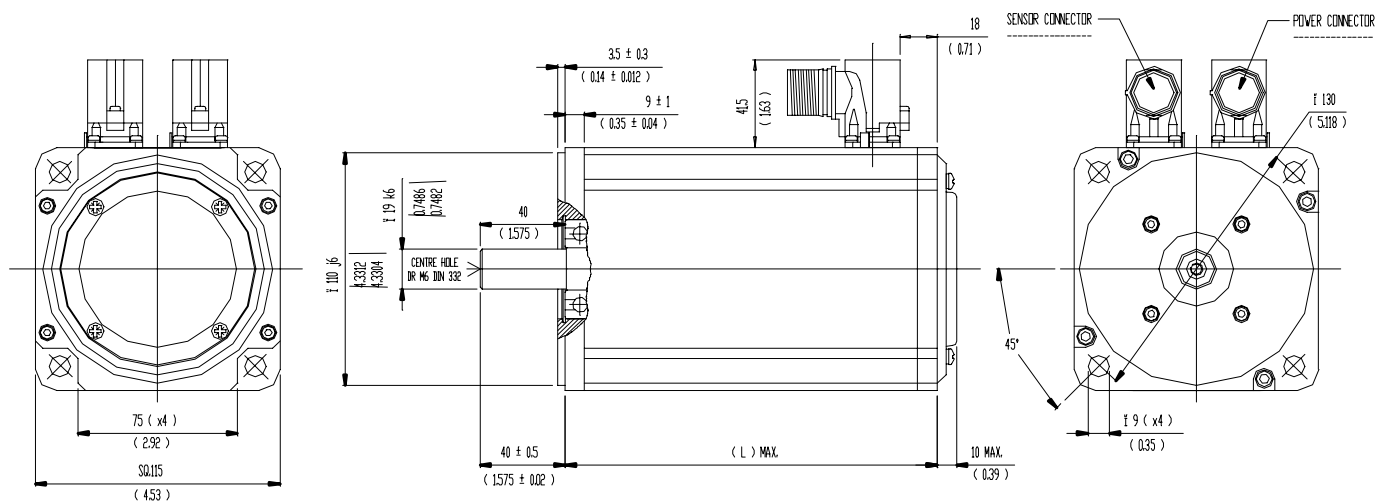

Motor	L Max	
	mm	Inches
3T42	185	7.3
3T43	210	8.3
3T44	235	9.2
3T45	260	10.2

Figure 3-11. Dimensions for MTR-3T4x-Series Servo Motors

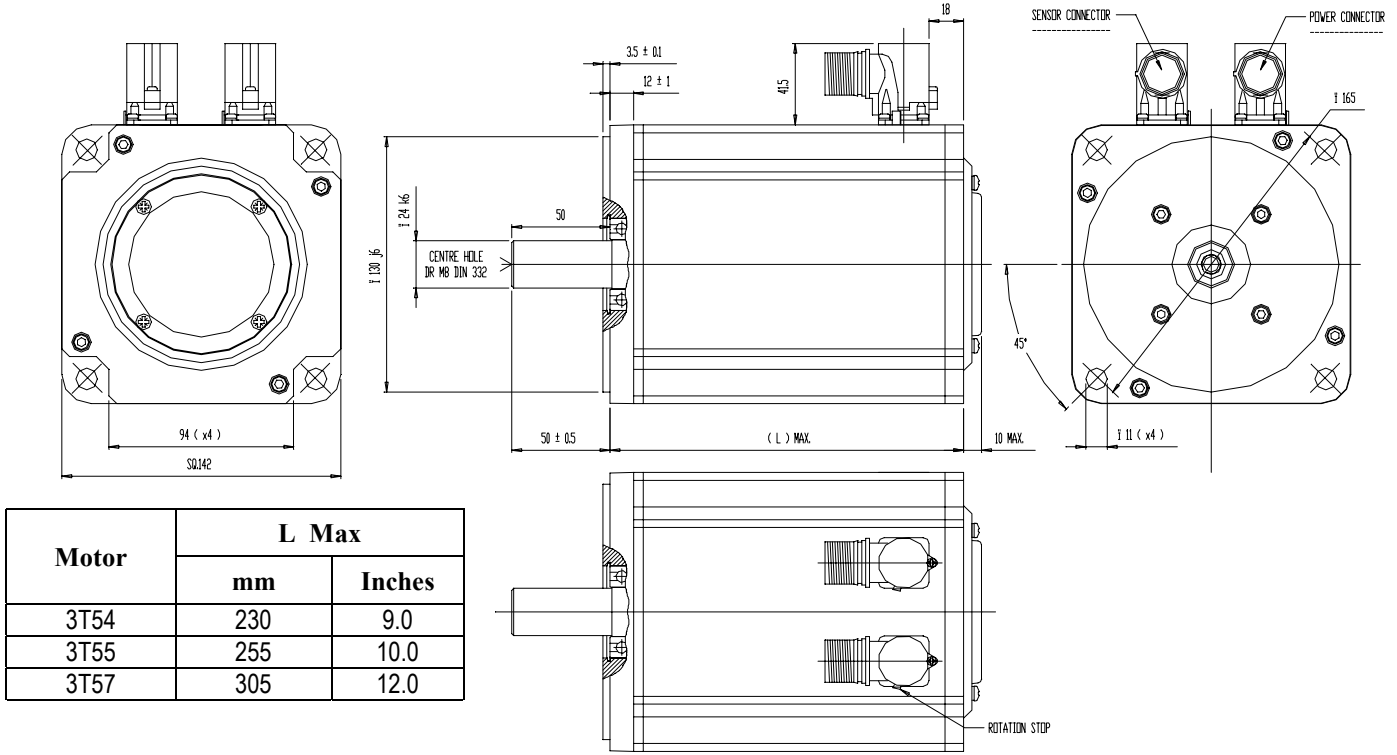

Figure 3-12. Dimensions for MTR-3T5x-Series Servo Motors

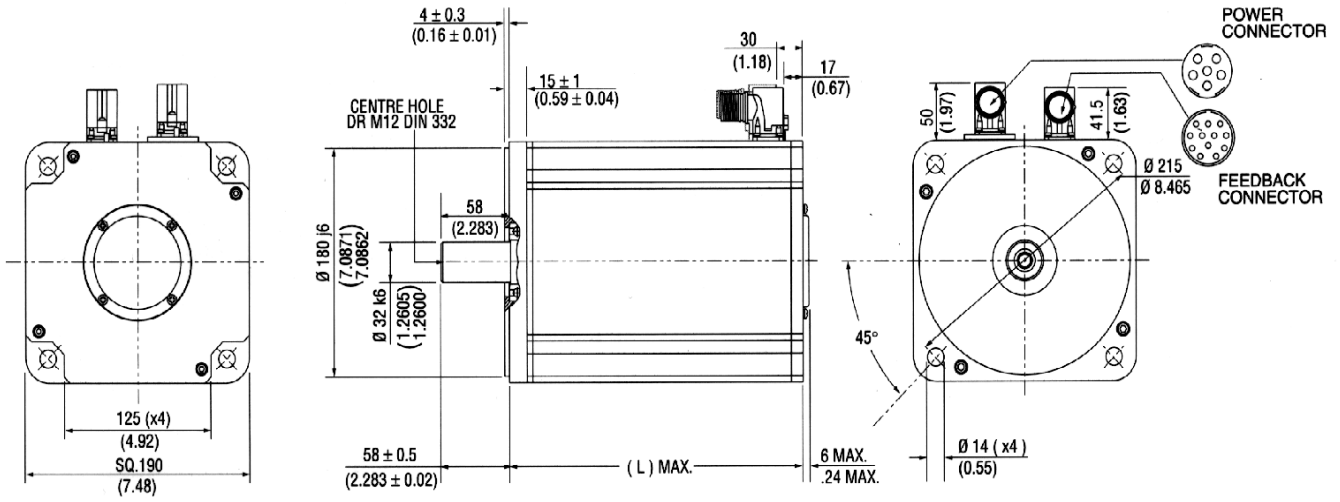
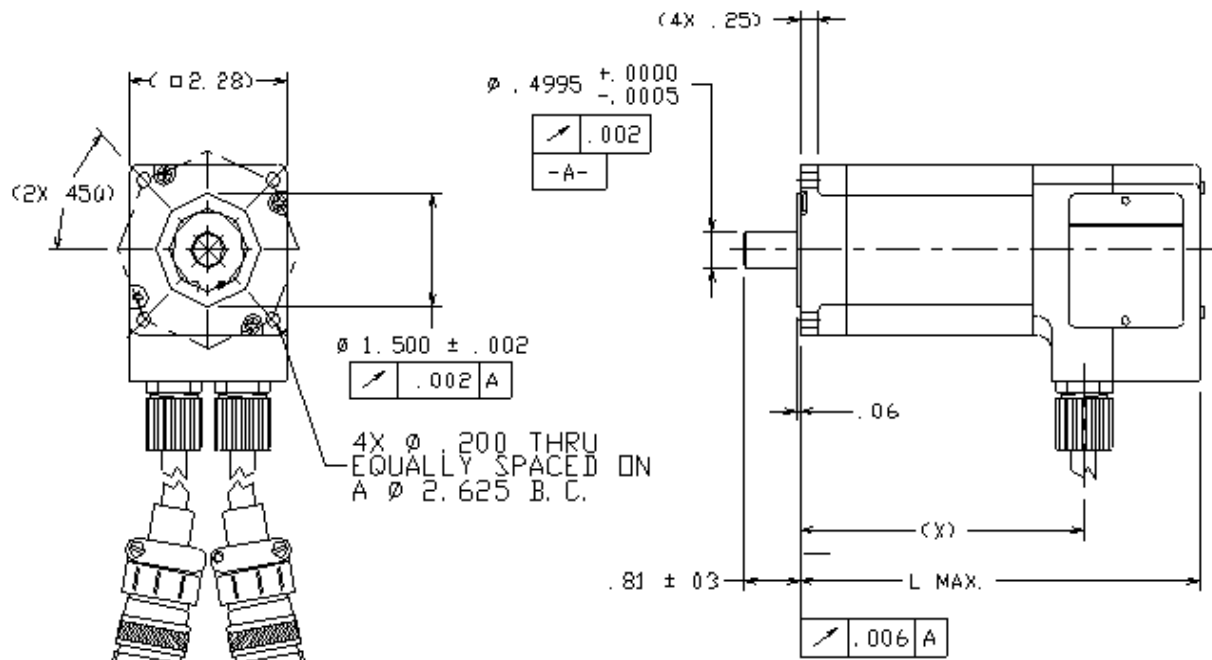
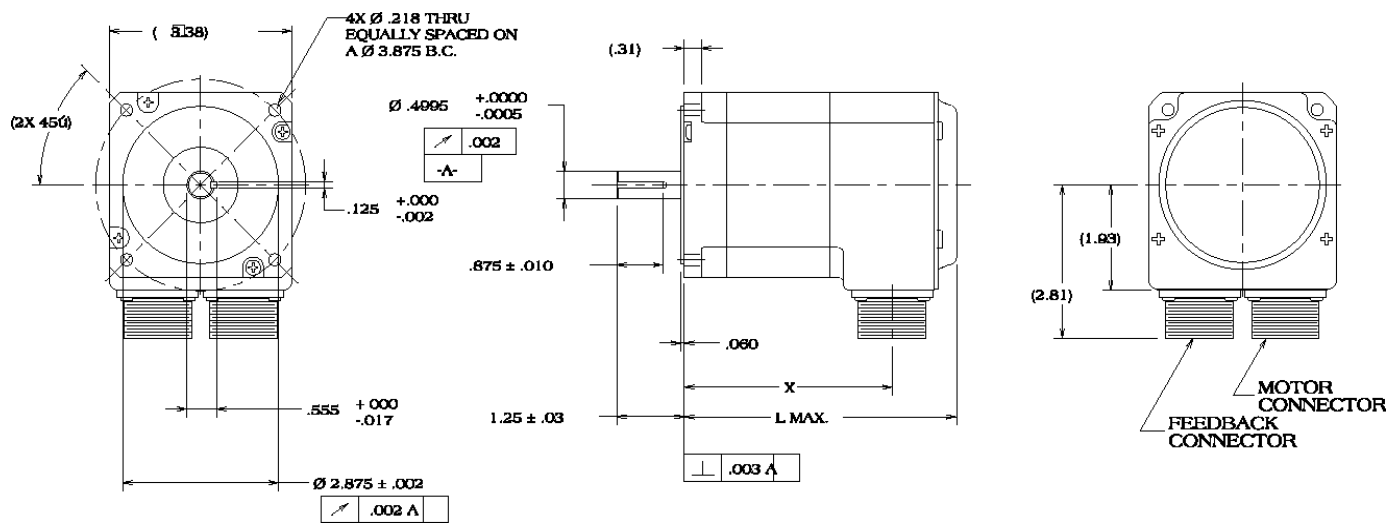

Figure 3-13. Dimensions for MTR-3T6x-Series Servo Motors



Motor	X		L Max		L Max (With Brake)	
	mm	Inches	mm	Inches	mm	Inches
3N21	78.7	3.1	124.5	4.9	185.7	7.31
3N22	104.1	4.1	149.9	5.9	211.1	8.31
3N24	154.9	6.1	200.7	7.9	261.9	10.31

Figure 3-14. Dimensions for MTR-3N2x-Series Servo Motors



Motor	X		L Max		L Max (With Brake)	
	mm	Inches	mm	Inches	mm	Inches
3N31	97.5	3.84	130.3	5.13	197.9	7.79
3N32	135.6	5.34	168.4	6.63	235.9	9.29
3N33	173.7	6.84	206.5	8.13	274.1	10.79

Figure 3-15. Dimensions for MTR-3N3x-Series Servo Motors

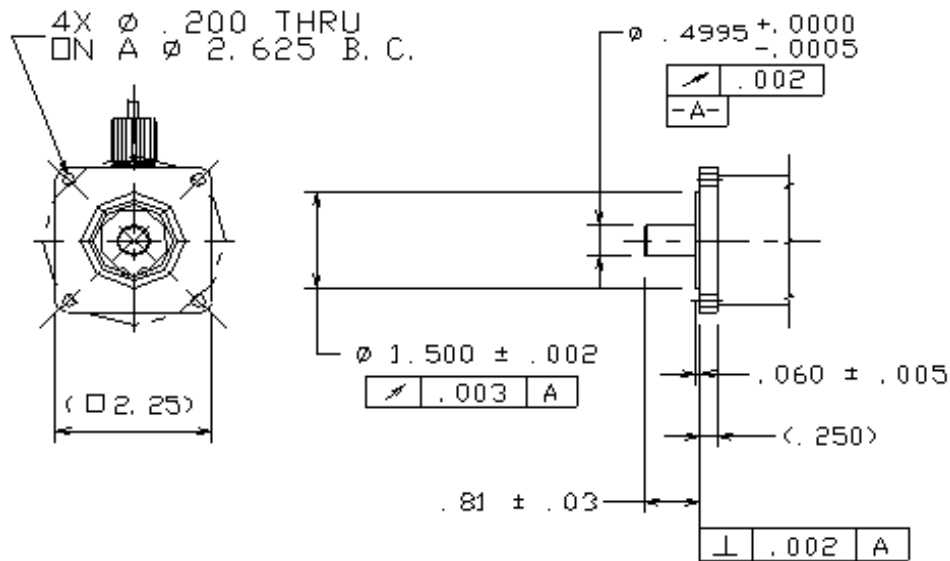
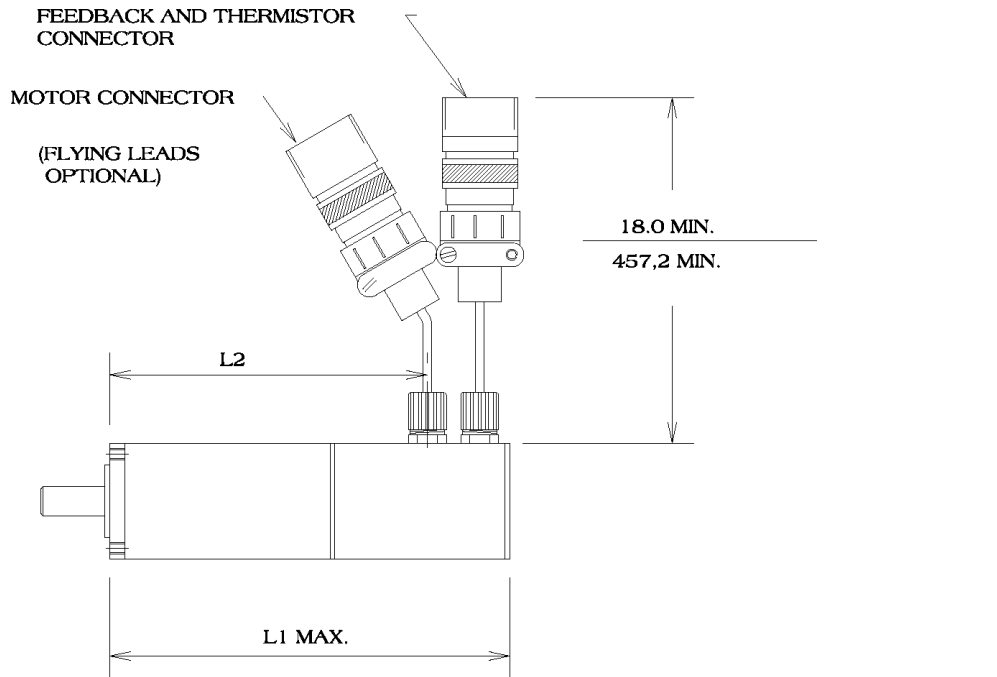

Motor	L1 Max		L2	
	mm	Inches	mm	Inches
3S22	187.9	7.4	149.9	5.9
3S23	212.9	8.38	176.0	6.93

Figure 3-16. Dimensions for MTR-3S2x-Series Servo Motors

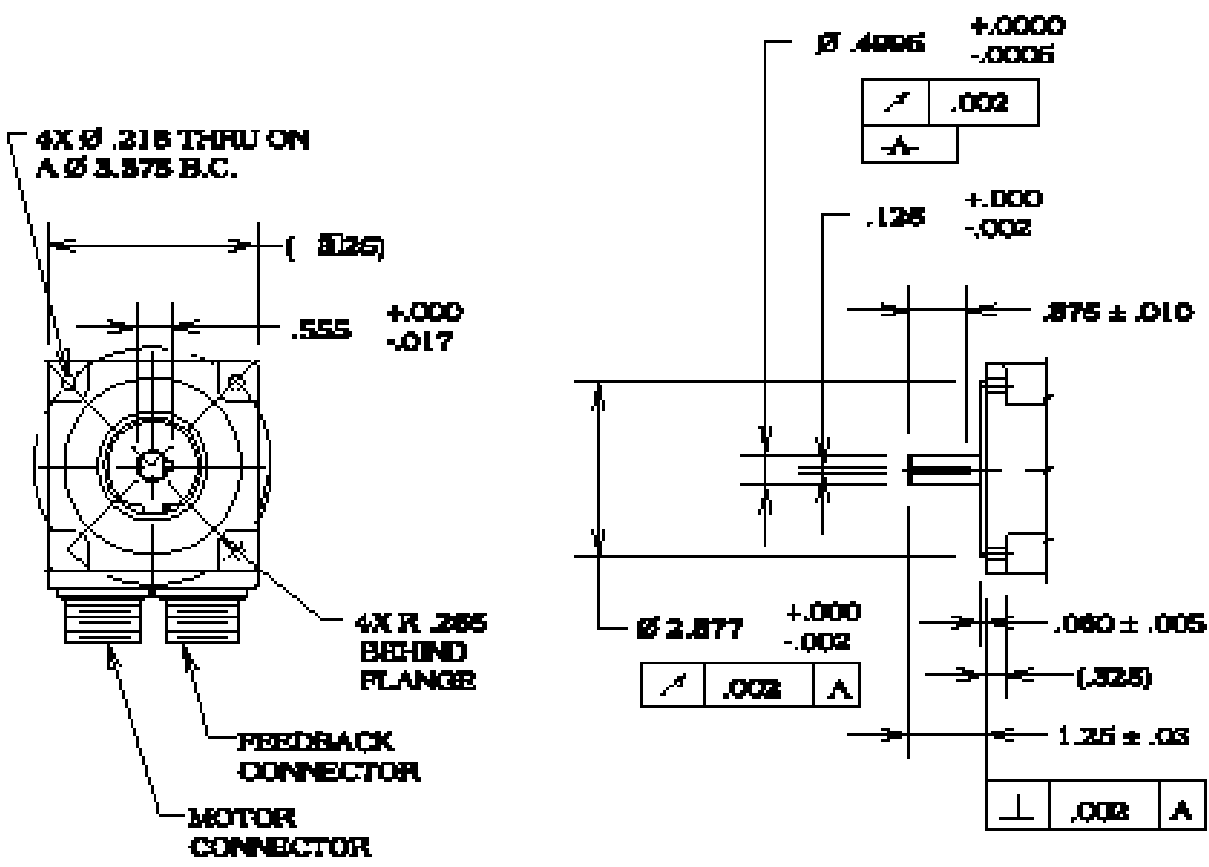

Motor	Brake	L1 Max		L2	
		mm	Inches	mm	Inches
3S32	No	180.1	7.09	142.7	5.62
	Yes	236.5	9.31	142.7	5.62
3S33	No	205.5	8.09	168.1	6.62
	Yes	261.9	10.31	168.1	6.62
3S34	No	230.9	9.09	193.5	7.62
	Yes	287.3	11.31	193.5	7.62
3S35	No	256.3	10.09	218.9	8.62
	Yes	312.7	12.31	218.9	8.62

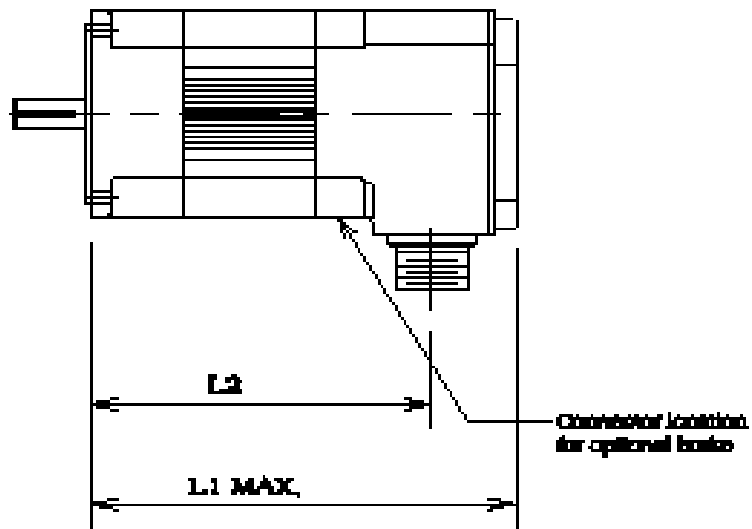
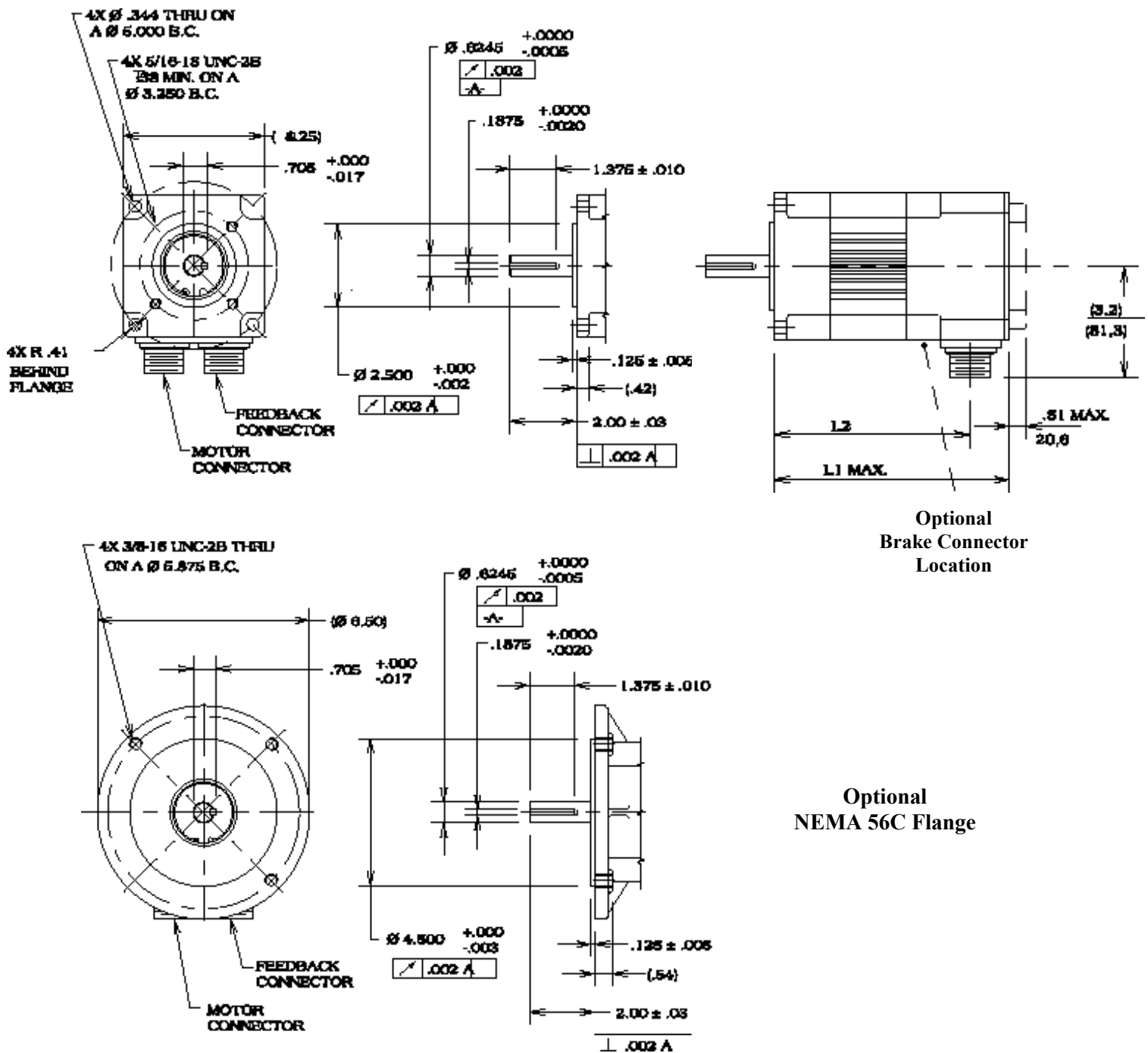
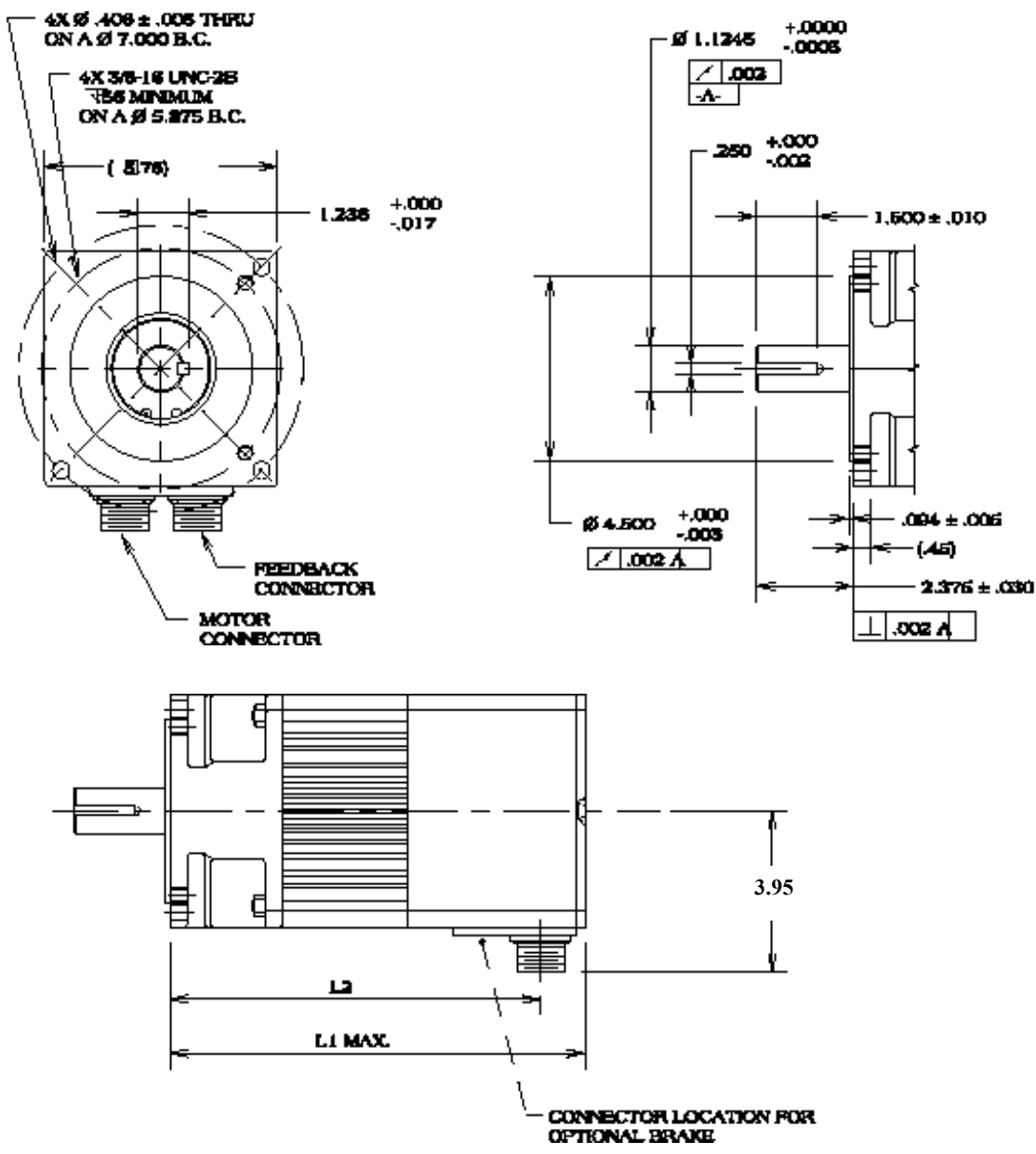

Figure 3-17. Dimensions for MTR-3S3x-Series Servo Motors



Motor	L1 Max		L1 Max (with Brake)		L2	
	mm	Inches	mm	Inches	mm	Inches
3S43	213.4	8.4	275.3	10.84	178.1	7.01
3S45	251.5	9.9	313.4	12.34	216.2	8.51
3S46	289.6	11.4	351.5	13.84	254.3	10.01

Figure 3-18. Dimensions for MTR-3S4x-Series Servo Motors



Motor	L1 Max		L1 Max (with Brake)		L2	
	mm	Inches	mm	Inches	mm	Inches
3S63	237.7	9.36	305.3	12.02	206.2	8.12
3S65	288.5	11.36	356.1	14.02	257.1	10.12
3S67	339.3	13.36	406.9	16.02	307.8	12.12

Figure 3-19. Dimensions for MTR-3S6x-Series Servo Motors

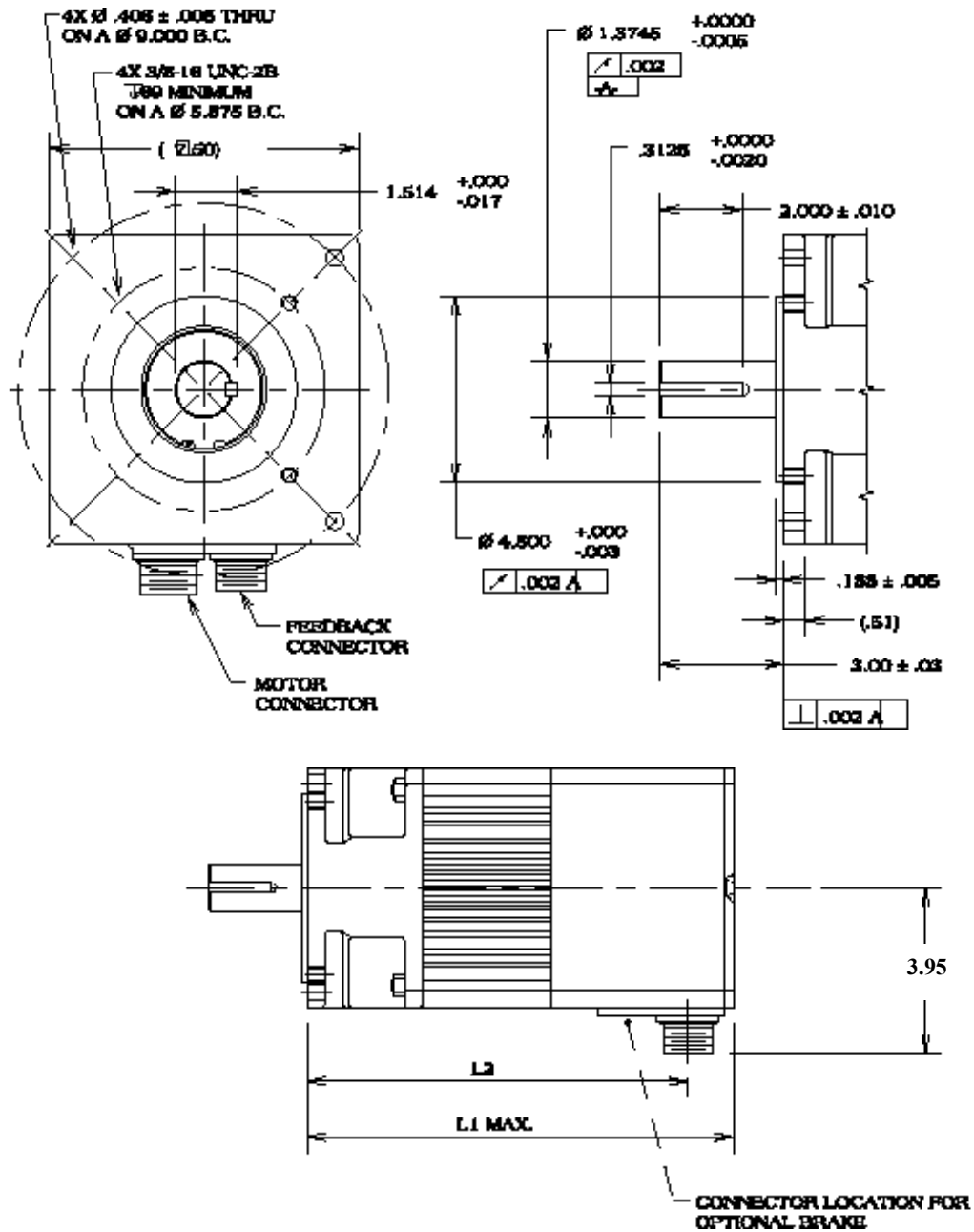

Motor	L1 Max		L1 Max (with Brake)		L2	
	mm	Inches	mm	Inches	mm	Inches
3S84	277.6	10.93	350.8	13.81	242.8	9.56
3S86	328.4	12.93	401.6	15.81	293.6	11.56
3S88	379.2	14.93	452.4	17.81	344.4	13.56

Figure 3-20. Dimensions for MTR-3S8x-Series Servo Motors

## 3.6 Wiring

### 3.6.1 General Wiring Considerations

See Chapter 2 for AC supply power requirements, fusing and isolation transformer ratings.

All input and output power must be in accordance with Class I, Division 2 wiring methods as defined in Article 501-4(b) of the National Electrical Code, NFPA 70 for installations within the United States, or as specified in Section 18-152 of the Canadian Electrical Code for installation within Canada.

Attach wiring connections for the main circuit according to Tables 3-1 and 3-5 while observing the following **cautions**:

#### Caution

**Use vinyl-sheathed or equivalent wire rated at 250 VAC or greater for 230 VAC S2K models or 600VAC or greater for 460 VAC S2K models . Wire size should be determined considering ampacity and codes.**

**Never** connect AC main power to motor output terminals.

**Never** allow wire leads to contact the enclosure.

**Never** operate the S2K amplifiers without an earth ground.

#### Warning

**When using this equipment in a Hazardous (classified) location:**

*Explosion hazard*--substitution of components may impair suitability for Class I, Division 2.

*Explosion hazard*--when in hazardous locations, turn off power before replacing or wiring modules.

*Explosion hazard*--do not disconnect equipment unless power has been switched off or the area is known to be non-hazardous.

### 3.6.2 AC Supply and Motor Wiring and Grounding

The mains input and motor output connections are made to the screw terminal connector located on the bottom of the S2K amplifier (see Figures 3-27 to 3-34). The amplifiers are designed to operate with input voltages as shown in the specifications in Chapter 2. No isolation transformer is required if the supply voltage is within the specified range. For the S2K servo amplifiers, the maximum achievable motor speed is directly related to the input voltage. For best performance connect these amplifiers to a three-phase 230 or 460 VAC power source depending on the rated voltage.



All of the terminals marked with the symbol  are connected to the chassis ground. Connect the  terminal at the mains input end of the connector to the panel earth ground. Connect the  terminal near the motor output terminals to the motor frame ground wire in the motor power cable. **DO NOT OPERATE THE S2K AMPLIFIERS WITHOUT AN EARTH GROUND.**

Table 3-1. Power Terminal Connections and Wire Sizes for SSD104 4.3 A Amplifier





Terminal Symbol	Description	Connect to...	Wire Size AWG
	Ground	Motor Ground	18-14
T	Motor Output Phase T	Motor Phase T	18-14
S	Motor Output Phase S	Motor Phase S	18-14
R	Motor Output Phase R	Motor Phase R	18-14
	Ground	Power System Ground	18-14
L3	Drive input power (do not connect for 1 phase input)	90 - 250 VAC	18-14
L2	Drive Input Power	90 - 250 VAC	18-14
L1	Drive Input Power	90 - 250 VAC	18-14



Table 3-2. Power Terminal Connections and Wire Sizes for SSD107 7.2 A Amplifier

Terminal Symbol	Description	Connect to...	Wire Size AWG <sup>1</sup>
	Ground	Motor Ground	18-14
T	Motor Output Phase T	Motor Phase T	18-14
S	Motor Output Phase S	Motor Phase S	18-14
R	Motor Output Phase R	Motor Phase R	18-14
	Ground	Power System Ground	18-14
2L2	Logic Input Power	90 - 250 VAC	18-14
2L1			
1L3	Drive Input Power (do not connect for 1 phase input)	90 - 250 VAC	18-14
1L2	Drive Input Power	90 - 250 VAC	18-14
1L1			
EXT	External Regen Resistor <sup>2</sup>	INT	18-14
INT	Internal Regen Resistor <sup>2</sup>	EXT	18-14
DC+	High Voltage DC Bus	Ext. Regen Resistor	18-14

1) AWG size for stranded copper wire. Minimum wire size required will depend on motor and load. Consult *National Electrical Code Handbook* ampacities tables for proper wire size.

2) The S2K amplifiers dissipate regenerated energy in an internal regeneration resistor. If the application produces more regenerated power than the rating of the internal resistor, the amplifier will report an EC fault code (excessive clamp dissipation). Contact GE Fanuc to determine if an external clamp resistor is required.

Table 3-3. Power Terminal Connections and Wire Sizes for SSD216 16A &amp; SSD228 28A Amplifier

Terminal Symbol	Description	Connect to...	Wire Size AWG <sup>1</sup>
R	Motor Output Phase R	Motor Phase R	16-10
S	Motor Output Phase S	Motor Phase S	16-10
T	Motor Output Phase T	Motor Phase T	16-10
	Ground	Motor Ground Terminal	16-10
DC+	High Voltage DC bus	External Regen Resistor	16-10
INT	Internal Regen Resistor <sup>2</sup>	EXT	16-10
EXT	External Regen Resistor <sup>2</sup>	INT	16-10
DC-	High Voltage DC bus	No Connection	16-10
1L1	Drive Input Power	180 - 250 VAC	16-10
1L2			
1L3			
	Ground	Power System Ground	16-10
2L1	Logic Input Power	180 - 250 VAC	18-14
2L2			

1) AWG size for stranded copper wire. Minimum wire size required will depend on motor and load. Consult *National Electrical Code Handbook* ampacities tables for proper wire size.

2) The S2K amplifiers dissipate regenerated energy in an internal regeneration resistor. If the application produces more regenerated power than the rating of the internal resistor, the amplifier will report an EC fault code (excessive clamp dissipation). Contact GE Fanuc to determine if an external clamp resistor is required.

Table 3-4. Power Terminal Connections and Wire Sizes for SSD407 7.2 A 460 VAC Amplifier





Terminal Symbol	Description	Connect to	Wire Size AWG <sup>1</sup>
	Ground	Motor ground terminal	16-10
T	Output phase T	Motor phase T	16-10
S	Output phase S	Motor phase S	16-10
R	Output phase R	Motor phase R	16-10
DC+	High voltage motor power bus	External clamp resistor	16-10
INT	Internal clamp resistor	EXT	16-10
EXT	External clamp resistor	INT	16-10
1L1	Drive input power	324 – 528 VAC	16-10
1L2			
1L3			
	Ground	Power system ground	16-10
COM +24V	Logic input power	18 – 30 VDC	18-14

Table 3-5. Power Terminal Connections and Wire Sizes for SSD420 20A Amplifier

Terminal Symbol	Description	Connect to	Wire Size AWG <sup>1</sup>
R	Output phase R	Motor phase R	16-10
S	Output phase S	Motor phase S	16-10
T	Output phase T	Motor phase T	16-10
	Ground	Motor ground terminal	16-10
DC+	High voltage motor power bus	External clamp resistor	16-10
INT	Internal clamp resistor	EXT	16-10
EXT	External clamp resistor	INT	16-10
DC-	High voltage motor power bus	No connection	
1L1	Drive input power	324 – 528 VAC	16-10
1L2			
1L3			
	Ground	Power system ground	16-10
COM	Logic input power	18 – 30 VDC	18-14
+24V			

- 1) AWG size for stranded copper wire. Minimum wire size required will depend on motor and load. Consult *National Electrical Code Handbook* ampacities tables for proper wire size.
- 2) The S2K amplifiers dissipate regenerated energy in an internal regeneration resistor. If the application produces more regenerated power than the rating of the internal resistor, the amplifier will report an EC fault code (excessive clamp dissipation). Contact GE Fanuc to determine if an external clamp resistor is required.

### 3.6.3 S-Series Servo Motor Encoder Wiring

Encoder feedback cables as shown in Table 3-9 are available from GE Fanuc for the S2K Series encoder-based amplifiers used with S-Series motors. Plug the motor end of the encoder cable into the connector on the motor and the DB-type connector end of the cable into the DB-15 socket on the front of the amplifier labeled *Position Feedback*. The best system reliability is achieved when the encoder cable is returned in a separate conduit from that housing the motor power cable. The feedback cable should use 24-28 AWG twisted pair wire and **must** be shielded. The shields must be terminated to the isolated ground pins on the *Position Feedback* (DB-15) connector on the S2K amplifier as shown in Table 3-6. Maximum serial encoder cable length is 15 meters. If two parallel 24 AWG wires are connected to both the +5v and ground (GND), as shown in Table 3-6, longer cable runs require the wire gauge to be increased to reduce the signal voltage drop. The S-Series motors require a 5V ±5% (4.75 to 5.25 VDC) power source for proper operation. See Section 3.6.9, “Connection Diagrams,” for additional wiring detail.

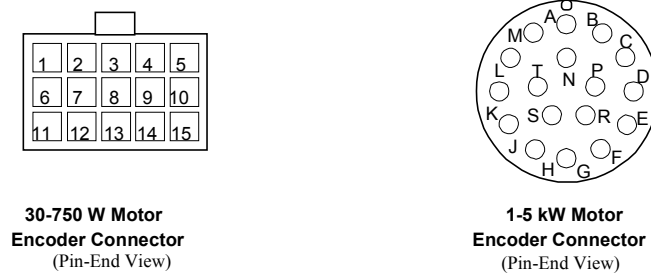

Figure 3-21. S-Series Servo Motor Serial Encoder Feedback Connectors

**Table 3-6. Serial Encoder Position Feedback Connections**

Connect From S2K DB-15P...		Connect To...	
Position Feedback Connector Pin Number	Signal Name	30-750 W S-Series Motor AMP Connector	1000-5000 W S-Series Motor MS-Style Connector
1	A+	1	A
2	B+	3	C
3	Z+	5	E
4	RX+	11	P
5	+5V	13	H
6	GND	14	G
7	NC	NC	NC
8	NC	NC	NC
9	A-	2	B
10	B-	4	D
11	Z-	6	F
12	RX -	12	R
13	+5V	13	H
14	GND	14	G
15	Shield	15	J

**Note**

The S2K amplifiers with encoder feedback include a proprietary serial encoder interface (RX, TX) that determines the motor rotor position to properly commutate the motor currents. Only GE Fanuc S-Series servo motors can be used with these S2K amplifiers.

### 3.6.4 S-Series Servo Motor Power and Brake Wiring and Grounding

Motor power and brake cables as shown in Table 3-9 are available from GE Fanuc for the S2K Series Servo Amplifiers. Cables for S-Series motors with brakes include two 18 AWG leads for connection of a 24Vdc brake power supply (see Table 2.1 for brake power requirements) and brake control logic. The brakes are of a fail-safe design, engaged by internal springs and disengaged by the application of 24 Vdc power.

The motor cable must have a motor ground wire that connects one of the frame ground terminals on the amplifier to the frame ground pin on the motor connector. Tables 3-1 to 3-5 show the proper wire size and Figure 3-22 shows the motor connector pin-out for each S-Series motor model. For noise sensitive applications a shielded motor power cable may be necessary. When used, the power cable shield should connect to the frame ground stud on the bottom of the amplifier and to the connector at the motor end. GE Fanuc’s standard motor power cables do **not** include a shield.

On the 30 – 750 Watt S-series motors, the power connectors shown below are wired to the motors with short leads and include a separate connector (and require a separate brake cable) when the optional holding brake is included. On the 1.0 – 5.0 kW motors, the MS-style connectors shown are mounted directly on the motor’s frame and the brake connections are included in the same connector and cable.

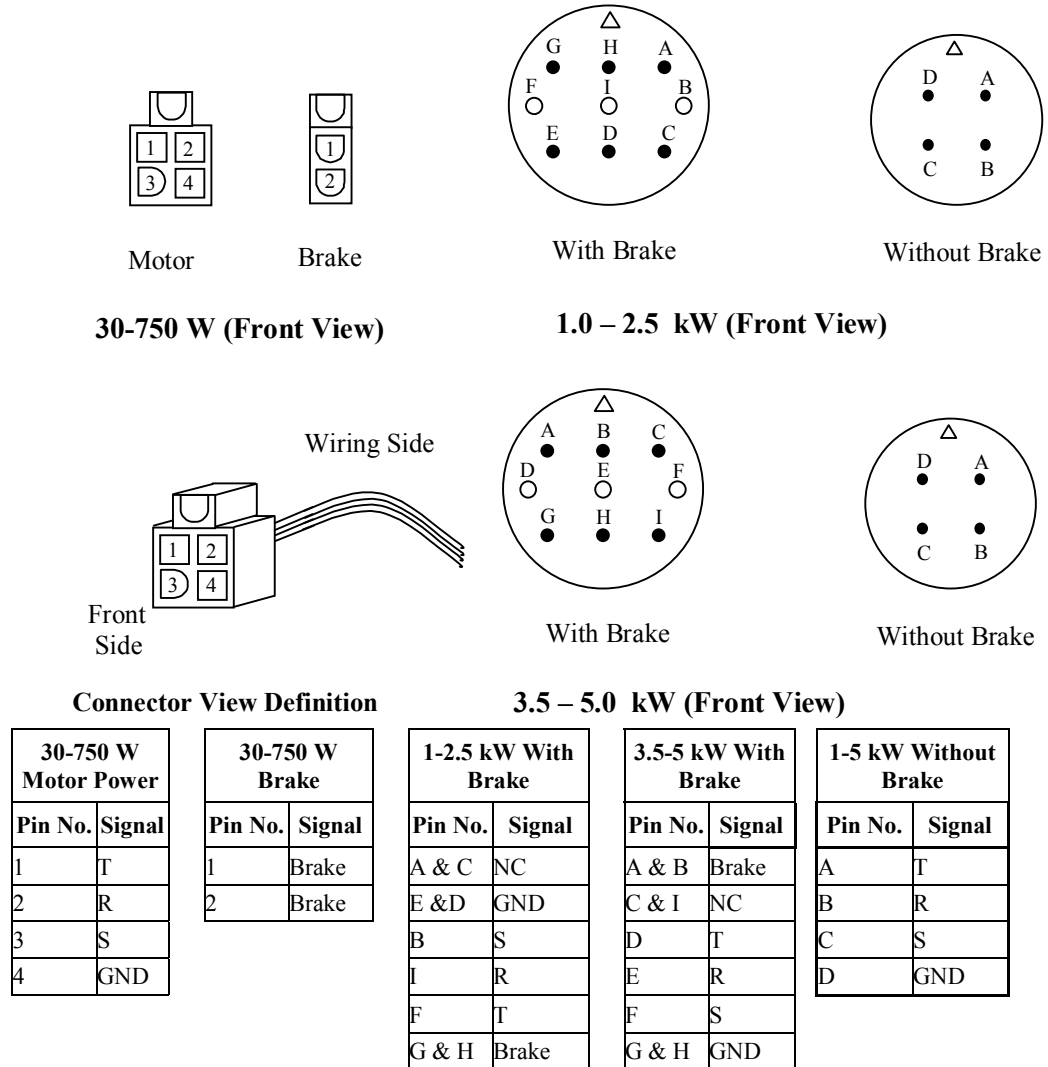

Figure 3-22. S-Series Motor Power Connections

### 3.6.5 MTR-Series Servo Motor Power and Brake Wiring and Grounding

Motor power and brake cables as shown in Table 3-9 are available from GE Fanuc for the S2K Series Servo Amplifiers. MTR-3T series motors with brakes include two additional leads for connection of a 24Vdc brake power supply (see Tables 2-8 through 2-10 for brake power requirements) and brake control logic into the motor power cable. MTR-3N and MTR-3S series motors with brakes use a physically separate brake power cable and connector. The brakes are of a fail-safe design, engaged by internal springs and disengaged by the application of 24 Vdc power.

The motor cable must have a motor ground wire that connects one of the frame ground terminals on the amplifier to the frame ground pin on the motor connector. Tables 3-1 to 3-5 show the proper wire size and Figures 3-23 and 3-24 show the motor connector pin-out for each motor model. For noise sensitive applications a shielded motor power cable may be necessary. When used, the power cable shield should connect to the frame ground stud on the bottom of the amplifier and to the connector at the motor end. GE Fanuc’s standard motor power cables do **not** include a shield.

Connector Pin	Motor
1	Phase T
2	Phase S
Ground	Earth Case
4	Optional Brake -
5	Phase R
E	Optional Brake +

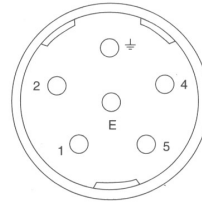

Figure 3-23. MTR-3T Series Motor/Brake Power Connections

Connector Pin	Motor
A	Phase T
B	Phase R
C	Phase S
D	Earth Case

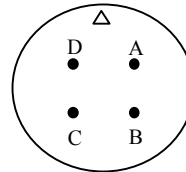

Figure 3-24. MTR-3N and MTR-3S Series Motor Power Connections

Connector Pin	Motor
A	Brake +
B	Brake -

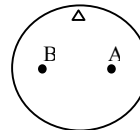

Figure 3-25. MTR-3N and MTR-3S Series Optional Brake Power Connections

### 3.6.6 MTR-Series Servo Motor Resolver Wiring

Resolver feedback cables as shown in Table 3-9 are available from GE Fanuc for the S2K Series resolver-based amplifiers used with MTR-Series motors. Plug the motor end of the resolver cable into the connector on the motor and the DB-type connector end of the cable into the DB-15 socket on the front of the amplifier labeled *Position Feedback*. The best system reliability is achieved when the encoder cable is returned in a separate conduit from that housing the motor power cable. The feedback cable should use 24-28 AWG twisted pair wire and **must** be shielded. The shields must be terminated to the isolated ground pins on the *Position Feedback* (DB-15) connector on the S2K amplifier as shown in Table 3-7. The maximum cable length for resolver feedback cables is 50 meters. See Section 3.6.9, “Connection Diagrams,” for additional wiring detail.

Table 3-7. Resolver Position Feedback Connections

Connect From S2K DB-15P...		Connect To...	
Position Feedback Connector Pin Number	Signal Name	MTR-3T Series Motor Connector	MTR-3N or MTR-3S Series Motor Connector
1	R1	5	E
2	R2	6	F
3	S1	1	D
4	S3	2	B
5	S2	4	C
6	S4	3	A
7	Therm	7	G
8	Therm	8	H
9	Shield	NC	NC
10	NC	NC	NC
11	Shield	NC	NC
12	NC	NC	NC
13	Shield	NC	NC
14	NC	NC	NC
15	Shield	NC	NC

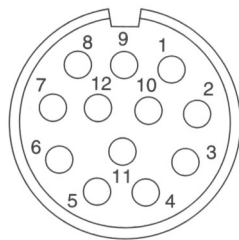

MTR-3T Series Motors

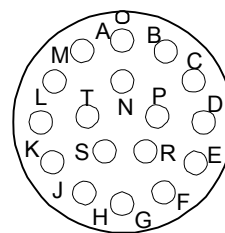

MTR-3N and MTR-3S Series Motors

Figure 3-26. MTR-Series Resolver Feedback Connections

### 3.6.7 Serial Communications Wiring

The S2K amplifiers include a 9-pin male D-Shell connector labeled *Serial Port* for RS-232 serial communications. This port allows you to connect a terminal emulator program or GE Fanuc's Motion Developer software in order to configure and tune the S2K amplifier for your application. GE Fanuc offers a 3 meter serial cable (IC800SKCS030) or you can make your own cable. Cable should be Belden 8723 shielded cable or equivalent. Pin-out for the serial cable is as follows:

S2K Connector Pin Number	Signal	PC Port Pin Number	Signal
1	No connection	1	No connection
2	Receive	2	Receive
3	Transmit	3	Transmit
4	Jumper to pin 7 on S2K connector	4	No connection
5	Ground	5	Ground/Shield
6	No connection	6	No connection
7	Jumper to pin 4 on S2K connector	7	No connection
8	No connection	8	No connection
9	No connection	9	No connection

Settings for the serial port are fixed at 9600 baud, 7 bits and odd parity. XON/XOFF flow control is used.

### 3.6.8 Auxiliary I/O Wiring

The Auxiliary I/O connector includes a number of diverse signals used to interface the S2K amplifier to your motion controller and machine. The functions available include:

- Analog Command Input (AI1)
- Torque Limit Analog Input (AI2)
- Analog Output (AO)
- +5 Vdc Output (for auxiliary encoder) (on the Pulse Input on SSD216 & SSD228 models)
- +12 Vdc Output (for Enable input)
- Enable Input
- OK Output
- Encoder Output
- Auxiliary Encoder Input (on the Pulse Input on SSD216, SSD228 & SSD420 models)

The Enable input and OK output may be wired for either sinking or sourcing operation. The operational voltage range is 12 to 24 volts DC. The OK output can sink or source 100 mA maximum. The wiring to the Auxiliary I/O connector should be of appropriate size and insulation quality for the application.

### SSD104, SSD107 and SSD407 Models

The Auxiliary I/O connector on these models is a standard 25-pin female D-shell connector and is wired according to the pin-out shown in Table 3-8 and the connection diagrams in section 3.6.9.

GE Fanuc offers several prefabricated connection options for the Auxiliary I/O signals. A breakout terminal board assembly (44A726268-001) and associated “plug-and play” interface cables (IC800SKCIxxx) make all of the signals available on screw terminals from a compact terminal block that can be panel or DIN-rail mounted. There are also flying lead cables (IC800SKCFLYxxx) that make all of the signals available on individual wires for direct connection into a user supplied terminal strip or the machine controller. See Table 3-9 for cable selection.

### SSD216, SSD228 and SSD420 Models

The Auxiliary I/O connector on these models is a standard screw terminal connector and is wired according to the pin-out shown in Table 3-8 and the connection diagrams in section 3.6.9. Because the connections are made to screw terminals, no prefabricated cable is offered for Auxiliary I/O connections for these models.

Detailed descriptions for each signal on the Auxiliary I/O connector are shown below.

**Table 3-8. Auxiliary I/O Connector Pin-out**

SSD104 SSD107 SSD407 Pin #	SSD216 SSD228 SSD420 Pin #	Signal Name	Description
1	1	AI1+	Positive for differential analog input 1 used for the $\pm 10$ Vdc command interface
2	3	AI2+	Positive for differential analog input 2 used as a $\pm 10$ Vdc torque limit input
3	6	AO	Positive for the general purpose analog output
4	Pulse Input	IN_A+	Positive for the A channel of the auxiliary encoder input
5	Pulse Input	IN_B+	Positive for the B channel of the auxiliary encoder input
6	Pulse Input	Tie	Used to bias the auxiliary encoder inputs when used in single-ended mode
7	19	+12 Vdc	12 Vdc regulated power output for use with Enable and OK signals (0.5 A max.)
8	8	Out_A+	Positive for the A channel of the encoder output
9	10	Out_B+	Positive for the B channel of the encoder output
10	12	Index +	Positive for the index (marker) channel of the auxiliary encoder output
11	14	Common	Signal common for internal 5 and 12 Vdc supplies. Not referenced to frame.
12	N/A	Enable -	Negative for the power output enable discrete input
13	N/A	OK -	Negative for the amplifier OK discrete output
14	2	AI1 -	Negative for differential analog input 1 used for the $\pm 10$ Vdc command interface
15	4	AI2 -	Negative for differential analog input 2 used as a $\pm 10$ Vdc torque limit input
16	5 & 7	Analog Common	Common reference for analog inputs and outputs
17	Pulse Input	IN_A-	Negative for the A channel of the auxiliary encoder input
18	Pulse Input	IN_B-	Negative for the B channel of the auxiliary encoder input
19	Pulse Input	+ 5 Vdc	5 Vdc regulated power output (0.25 A max. current) for auxiliary encoder power

SSD104 SSD107 SSD407  Pin #	SSD216 SSD228 SSD420  Pin #	Signal Name	Description
20	14 & 20	Common	Signal common for discrete inputs and outputs
21	9	Out_A -	Negative for the A channel of the encoder output
22	11	Out_B -	Negative for the B channel of the encoder output
23	13	Index -	Negative for the index (marker) channel of the auxiliary encoder output
24	15	Enable +	Positive for the power output enable discrete input
25	16	OK +	Positive for the amplifier OK discrete output
N/A	17	Input Common	Common side of the Enable discrete input optocoupler. Not referenced to any internal voltages or ground points.
N/A	18	Output Common	Common side of the OK SS relay output. Not referenced to any internal voltages or ground points.

### Command Input (Analog Input 1)

The differential command input is intended to be used as a  $\pm 10\text{Vdc}$  torque or velocity command interface to a host motion controller when the amplifier is configured for either velocity or torque (default) operating mode. The Motion Type (MT) parameter determines the amplifier operating mode. The Analog Input Deadband (AIB1) and Analog Input Offset (AIO1) parameters are used to configure the deadband and voltage offset for this input. See Chapter 5 for detailed descriptions of these parameters.

The gearing ratio parameters (GRN and GRD) can be used to scale the command voltage to represent a specific motor speed or torque at a given voltage input. The base scaling of the command input for a ratio of 1 (GRN/GRD = 1) for each operating mode is as follows:

Velocity Mode (MT=VEL):	1228.8 Motor RPM/Command Volt
Torque Mode (MT=TORQ):	10% Amplifier Peak Current/Command Volt

To enable the scaling, the *Gearing Enable* parameter must be set (GRE=1).

Use 20-28 AWG twisted-pair wire with an overall shield for this cable. For best noise immunity connect the shield to the low side of the differential command input on the sourcing (host) side of the cable. Also, as a common mode reference, tie the analog common pin on the Auxiliary I/O connector to the common reference for the command signal on the host controller. (See connection diagrams in Section 3.6.9). The internal schematic for the analog input circuit is shown below.

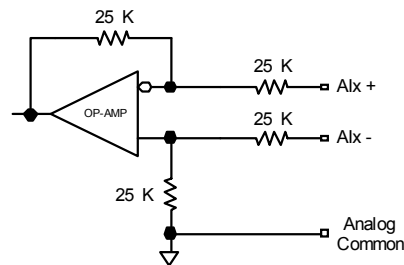

### Torque Limit Analog Input (Analog Input 2)

This differential input is intended to be used as a  $\pm 10\text{Vdc}$  torque limit reference input when the amplifier is configured for either velocity or torque (default) mode. The Motion Type (MT) parameter determines the amplifier operating mode. The S2K amplifiers can be configured to allow the torque limit setting to be changed on-the-fly using this analog input. When the Torque Limit Enable (TLE) parameter is set to 2, the **absolute value** of analog input 2 sets the torque (current) limit of the amplifier as follows:

$$10\text{V} = \text{Full continuous rated torque (current)}$$

If your application requires a fixed torque limit, you should use the TLC parameter rather than the torque limit analog input. The Analog Input Deadband (AIB2) and Analog Input Offset (AIO2) parameters are used to configure the input deadband and voltage offset for this input. See Chapter 5 for detailed descriptions of these parameters.

Use 20-28 AWG twisted-pair wire with an overall shield for this cable. For best noise immunity connect the shield to the low side of the differential command input on the sourcing (host) side of the cable. Also, as a common mode reference, tie the analog common pin on the Auxiliary I/O connector to the common reference for the command signal on the host controller. (See connection diagrams in Section 3.6.9.) The internal schematic for the analog input circuit is shown above.

## Analog Output (AO)

The hardware analog output is primarily used as a diagnostic output for various signals used in the tuning and debugging process. The *Analog Common* pin is used for the signal return. The Analog Output (AO) software parameter allows you to configure this output to represent one of the following signals:

- Actual velocity (AO = VLA)
- Actual output current (AO = CMD)
- Following error (AO = FE)

The output can also be forced to a specific voltage value by setting the AO parameter to the desired voltage from a PC terminal emulator or Motion Developer terminal window. This operation is useful during system start-up and tuning by using the analog output as a command source for either velocity or torque mode. By wiring the analog output directly into the command input (AI1) on the amplifier you can force discrete command settings to jog the axis and verify machine operation.

Use 20-28 AWG twisted-pair wire with an overall shield for this signal interface. For best noise immunity connect the shield to the *Analog Common* pin on the Auxiliary I/O connector. The internal schematic for the analog output circuit is shown below.

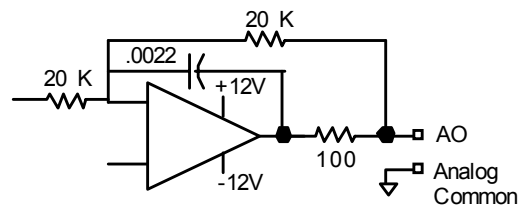

## Auxiliary Encoder Input (IN\_A, IN\_B)

The S2K amplifier includes an electronic gearing mode that allows the motor to follow a master encoder (follower) or pulse command source (stepper emulator). The Auxiliary Encoder Type (QTX) register configures this input for one of the following signal types:

- Pulse/Direction input
- CCW/CW pulse input
- Quadrature (encoder) input

By setting the Motion Type register to position mode (MT = POS) you configure the gearing mode, and the amplifier will follow pulses on the auxiliary encoder input based on the gearing ratio. This ratio is set using the Gearing Numerator (GRN) and Gearing Denominator (GRD) registers. The Gearing Enable (GRE) register is then used to enable or disable the gearing mode and the Gearing Bound (GRB) register sets the maximum velocity (pulses/second) that the electronic gearing mode can command. The auxiliary encoder input does not include an index (marker) input since it is used for simple pulse following and so there is no need for a master reference position. When the auxiliary encoder inputs are used with a single ended signal source, see the section titled “Tie” below.

Note that on the SSD216 and SSD228 models, the auxiliary encoder input and the +5Vdc output are located on the Pulse Input connector on the bottom of the amplifier. The internal schematic for the encoder input circuit is shown below.

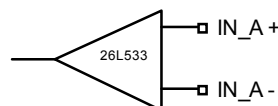

### Tie (For single ended encoder input)

The Tie point allows the auxiliary encoder inputs to be used as single-ended inputs. This terminal is internally connected to a 2.5 Vdc source through a 1 k $\Omega$  current limiting resistor. Typically, the Tie point is connected to the IN\_A- and IN\_B- input terminals to bias the line receiver. Note that on the SSD216 and SSD228 models, this terminal is located on the Pulse Input connector on the bottom of the amplifier. For single-ended open collector encoder signals, a 470  $\Omega$  pull-up resistor is required. The internal schematic for the tie terminal is shown below.

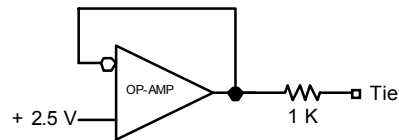

### Encoder Output (Out\_A, Out\_B, Index)

The S2K amplifier is typically used in applications controlling motor position where a host motion controller closes the position loop and interfaces to the amplifier using either an analog velocity or torque command. Since the S2K amplifier requires position feedback from the motor to properly commutate the currents, the motor position feedback must connect to the amplifier. The host controller also requires position feedback from the motor (unless a second feedback device is mounted to the load) to close the position loop. For S-Series motors the encoder output buffers the motor encoder input and makes it available as quadrature (A-channel, B-channel & index) signals to the motion controller. The S-Series motor encoder resolution is 2500 pulses per revolution, so the feedback to the host controller supports a maximum 10,000 quadrature counts/revolution. For MTR-Series motors the resolver-based S2K derives quadrature encoder signals from the resolver feedback with a maximum resolution of 1024 pulses per revolution (4096 quadrature counts per revolution). This maximum resolution can be scaled down to one of several predefined lower resolution values using the Encoder Output Type (EOT) register.

For best results use 20-28 AWG twisted-pair wires with individual shields on each wire pair and an overall shield. For best noise immunity connect the cable shield to one of the *common* inputs on the Auxiliary I/O connector. The typical internal schematic for each of the encoder output circuits is shown below.

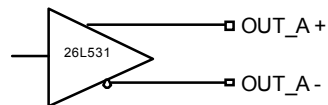

### Enable Input

The Enable discrete input allows the host controller to enable or disable the power output stage of the amplifier. The Enable input must be active to run the servo motor. The Enable input is also used to reset faults on the amplifier. When a fault occurs the Enable input must be cycled low to high to reset the faults. The current state of the Enable input can be queried using the Fault Code (FC) register in the terminal window. The Enable input should be connected as shown in the connection diagrams in Section 3.6.9. The internal schematic for the enable input circuit is shown below.

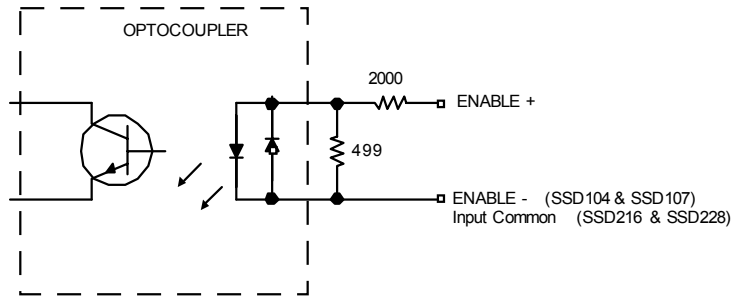

### OK Output

The OK discrete output allows the S2K to communicate status information to the host controller. The OK output is active when the amplifier is enabled and no faults are present. The S2K LED status register will display OK when this output is active. The internal schematic for the OK output circuit is shown below.

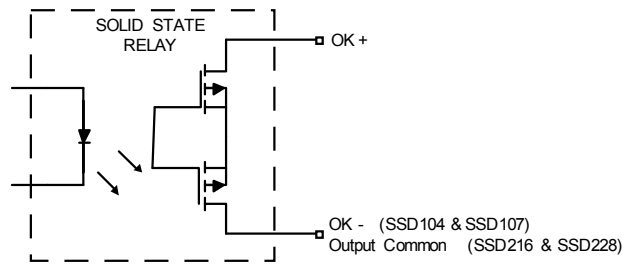

### 3.6.9 Connection Diagrams

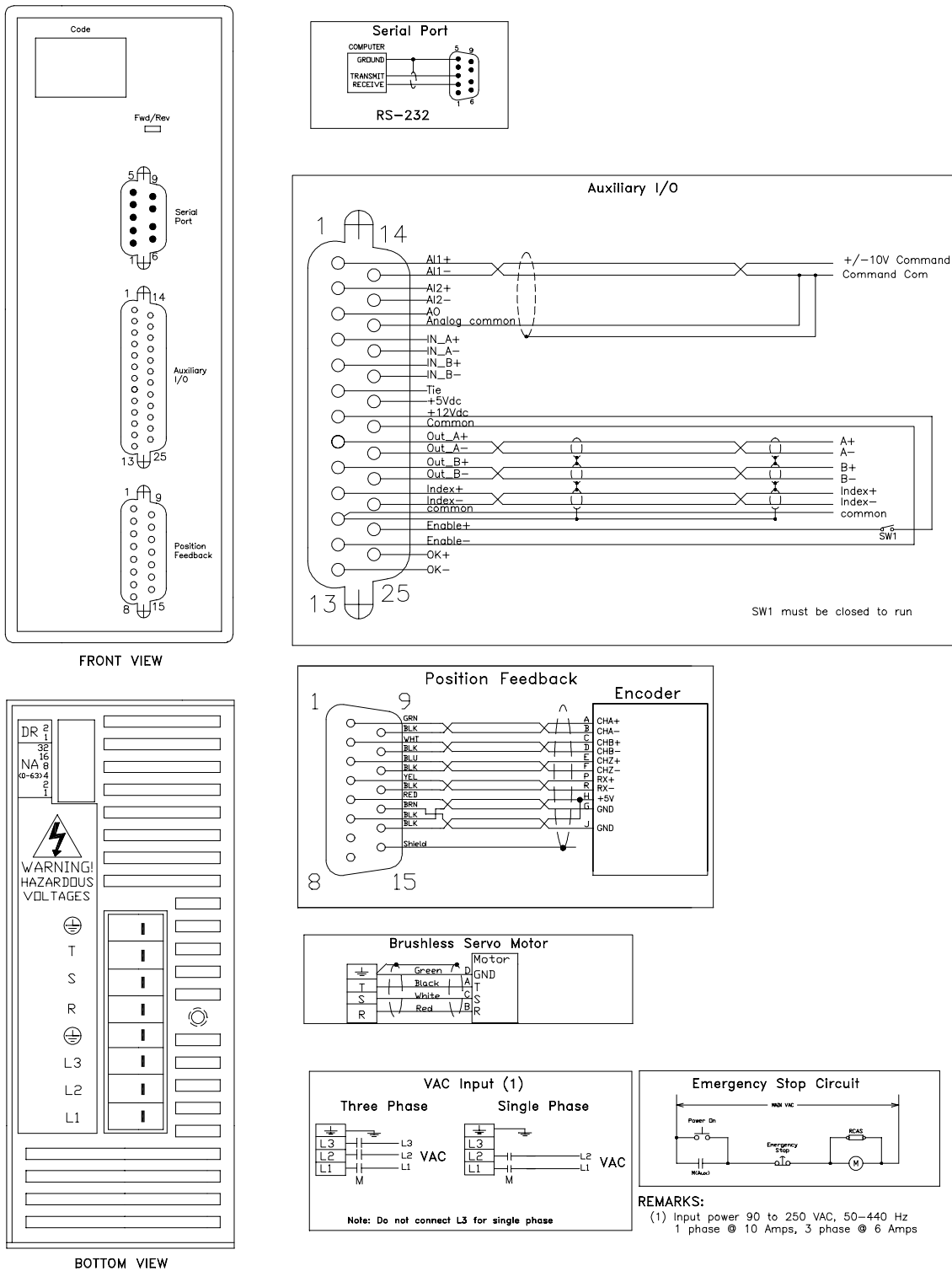
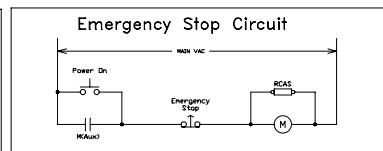
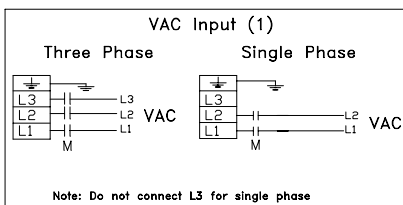
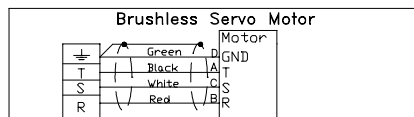
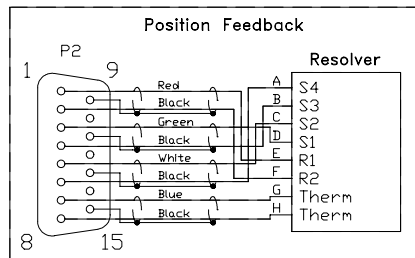
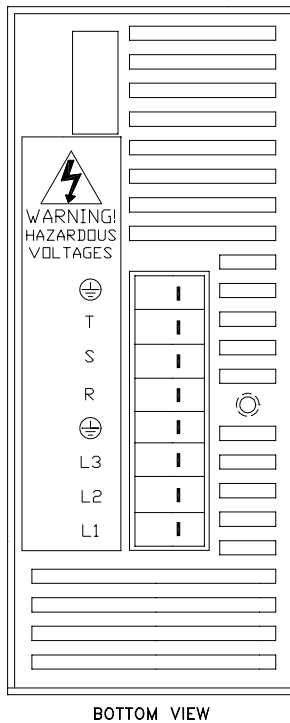
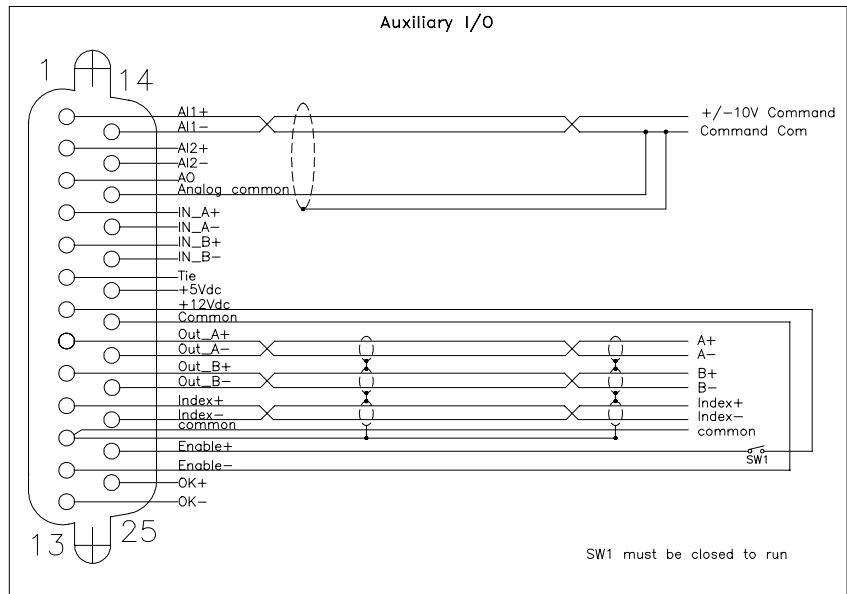
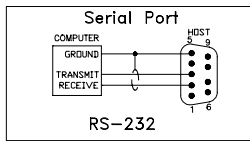
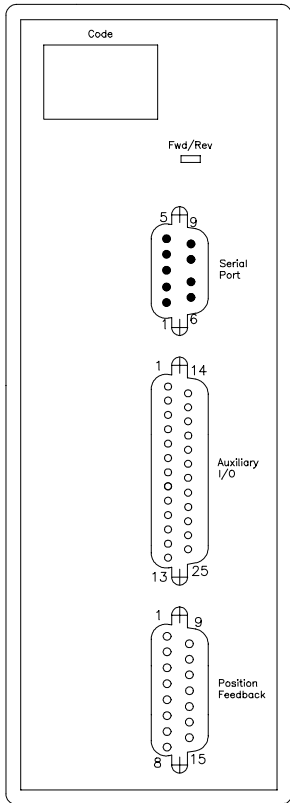

Figure 3-27. Connection Diagram for the 4.3 A 115/230 VAC Serial Encoder-Based Servo Amplifier (SSD104)



**REMARKS:**

(1) Input power 90 to 250 VAC, 50-440 Hz  
 1 phase @ 10 Amps, 3 phase @ 6 Amps

Figure 3-28. Connection Diagram for the 4.3 A 115/230 VAC Resolver-Based Servo Amplifier (SSD104R)

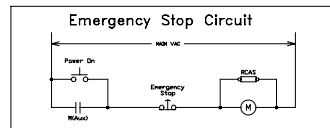
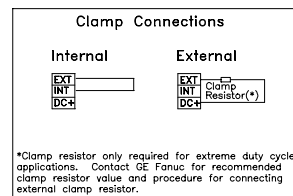
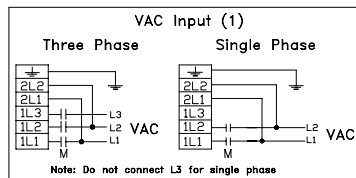
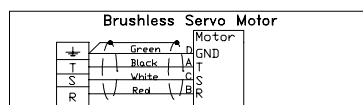
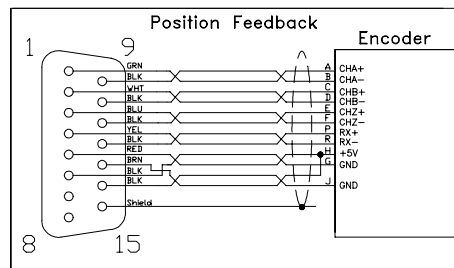
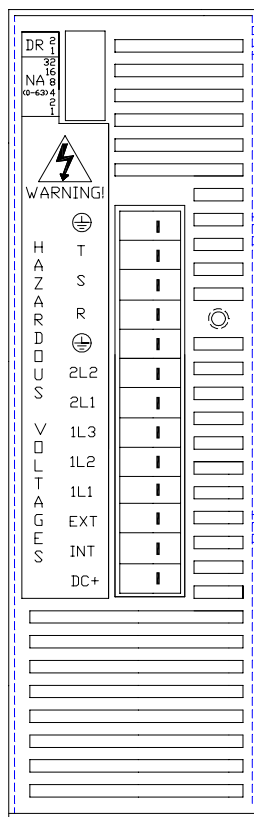
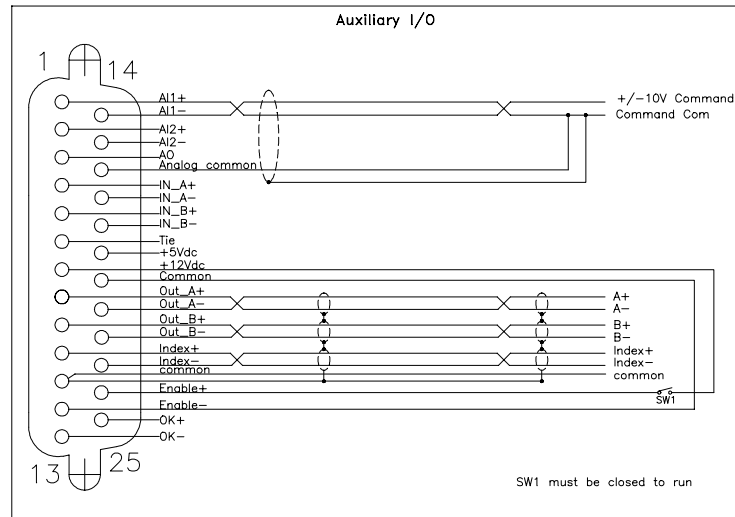
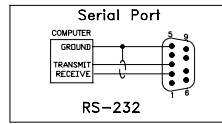
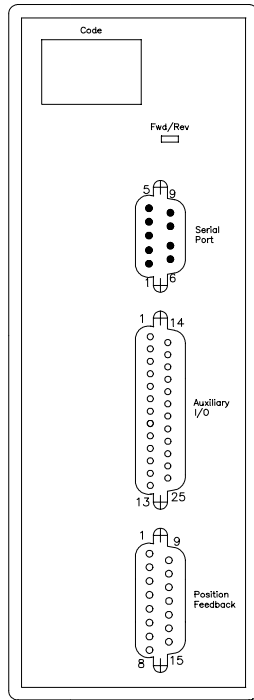

**REMARKS:**

(1) Input power 90 to 250 VAC, 50-440 Hz  
 1 phase @ 15 Amps, 3 phase @ 8 Amps

Figure 3-29. Connection Diagram for the 7.2A 115/230 VAC Serial Encoder-Based Servo Amplifier (SSD107)

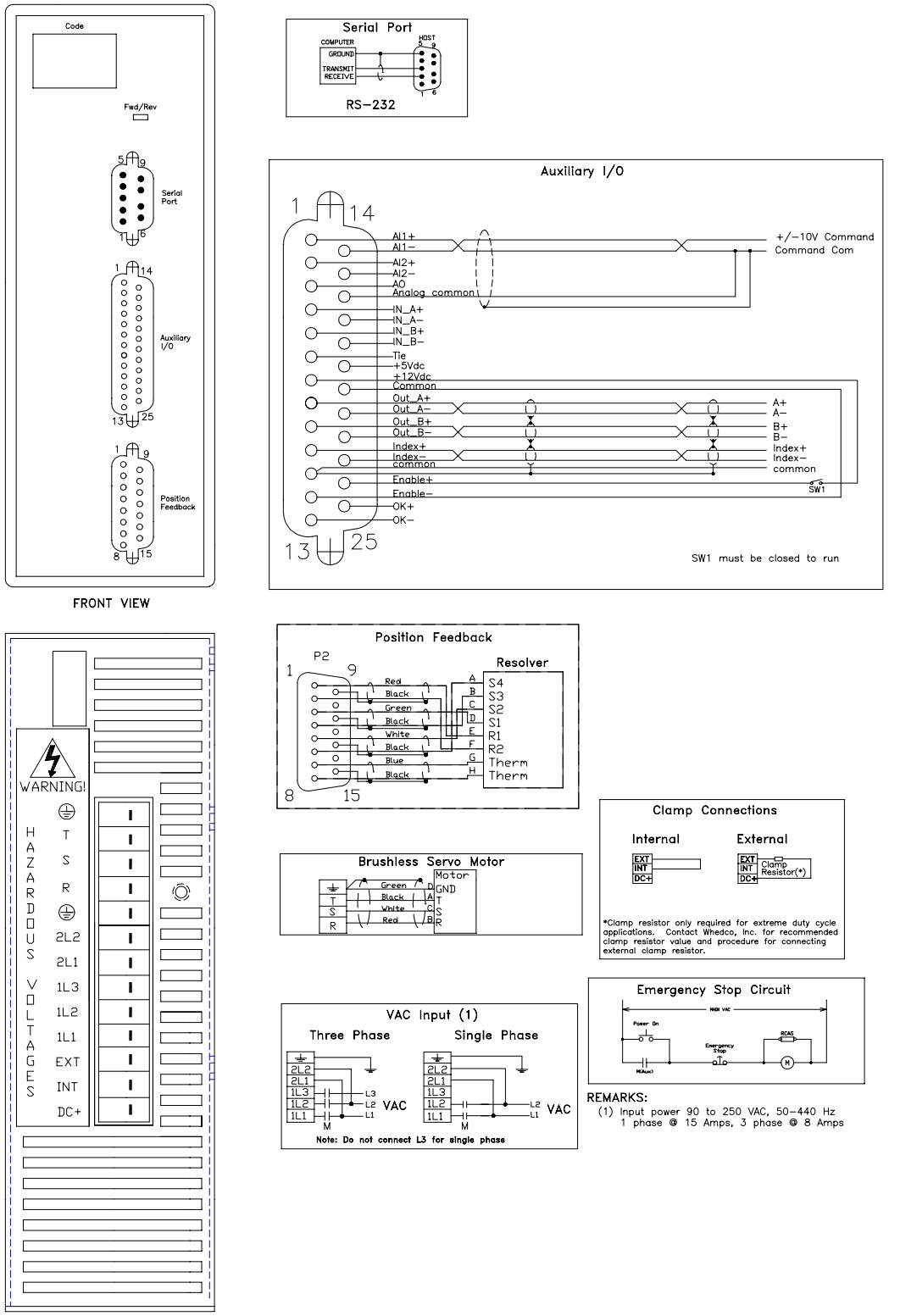

Figure 3-30. Connection Diagram for the 7.2A 115/230 VAC Resolver-Based Servo Amplifier (SSD107R)

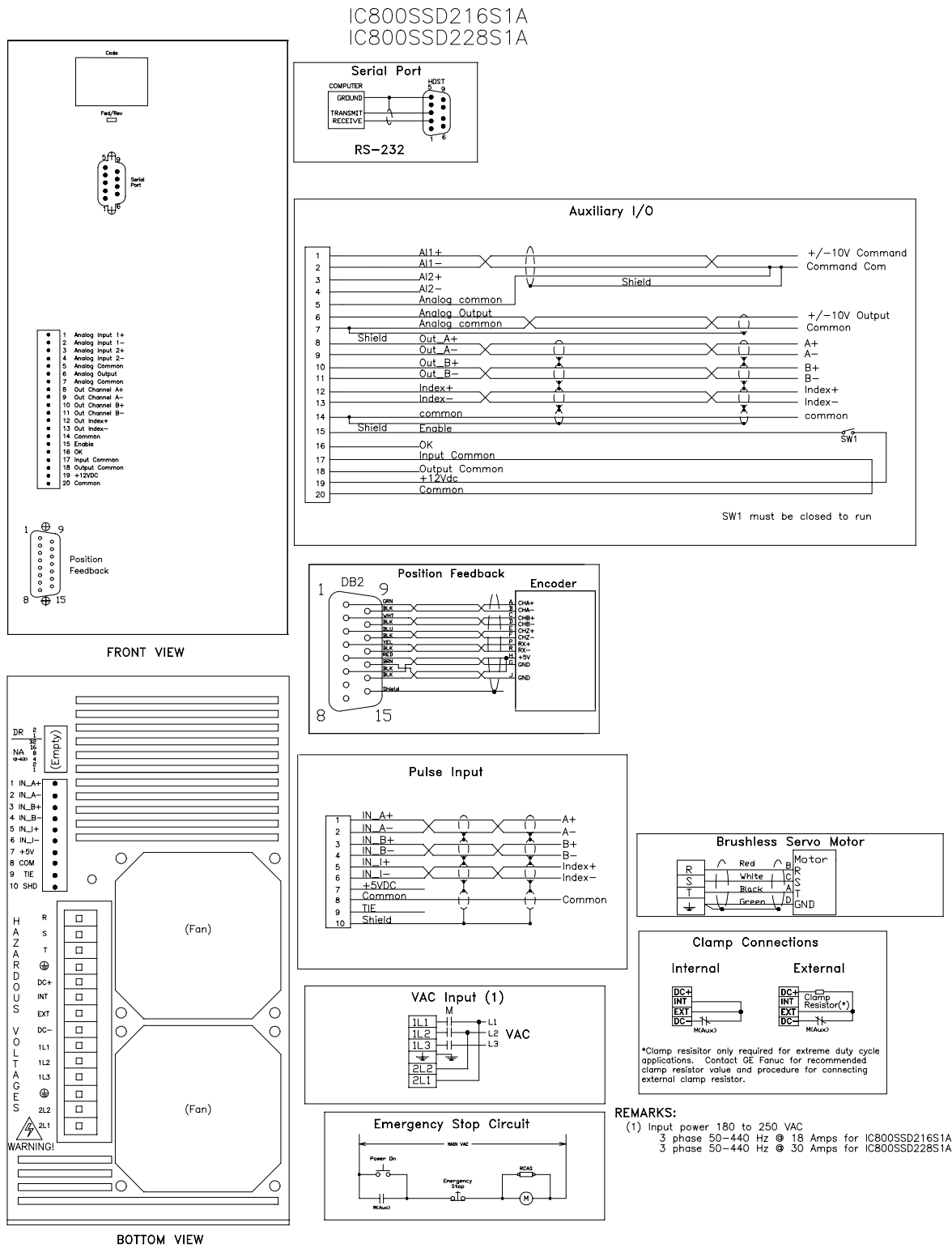

Figure 3-31. Connection Diagram for the 16 A & 28 A 230 VAC Serial Encoder-Based Servo Amplifiers (SSD216 & SSD228)

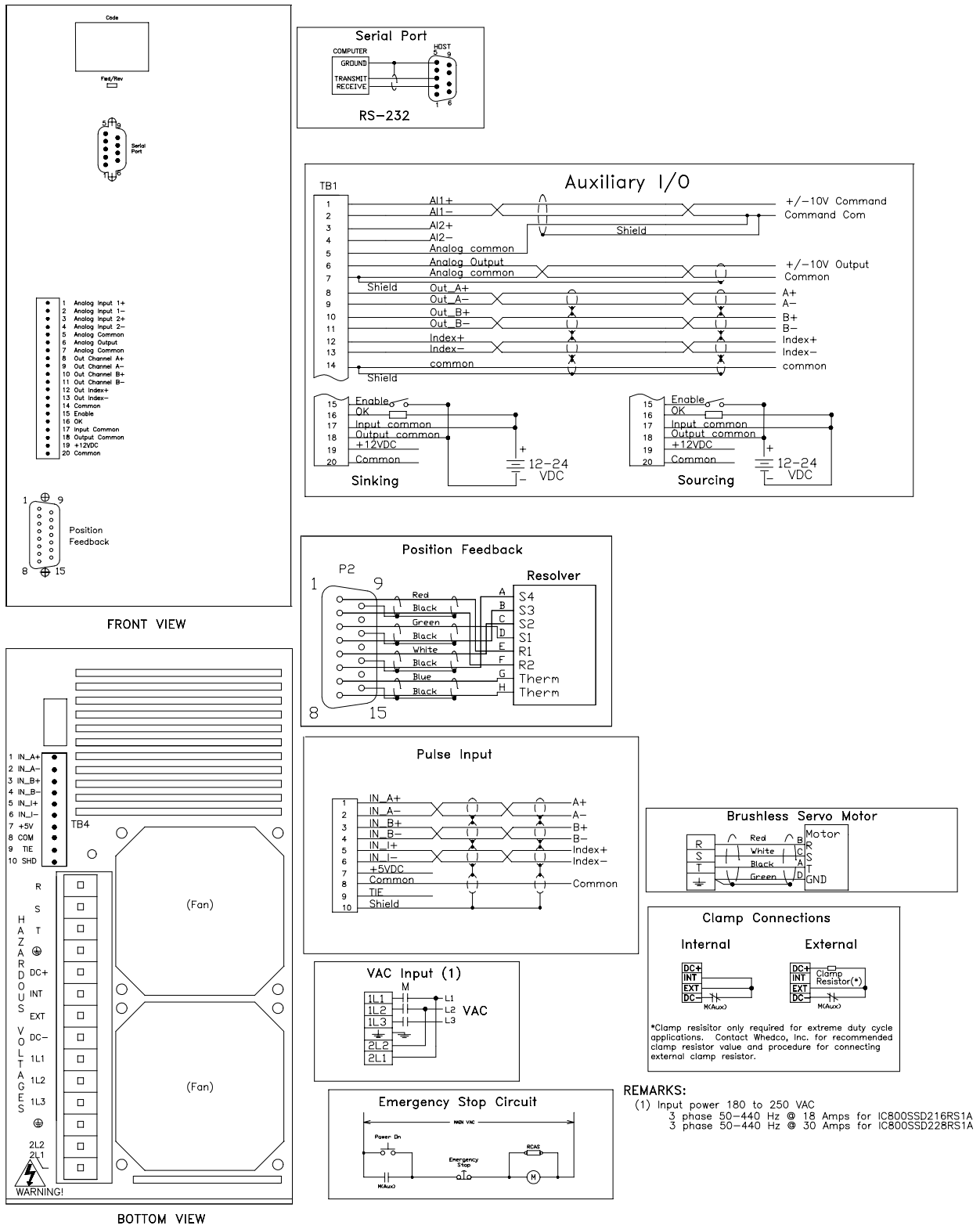

Figure 3-32. Connection Diagram for the 16 A & 28 A 230 VAC Resolver-Based Servo Amplifiers (SSD216R & SSD228R)

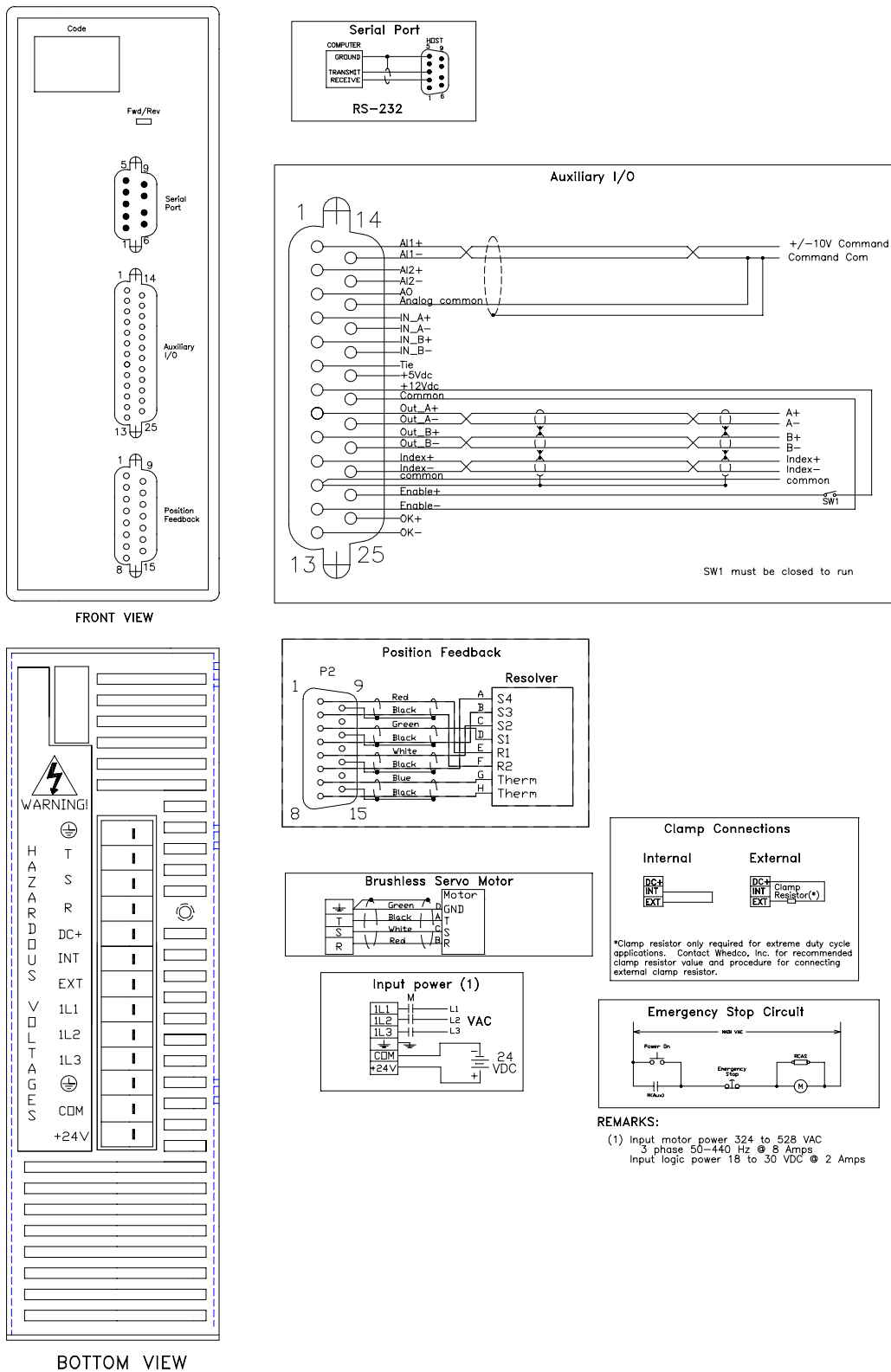

Figure 3-33. Connection Diagram for the 7.2A 460 VAC Resolver-Based Servo Amplifier (SSD407R)

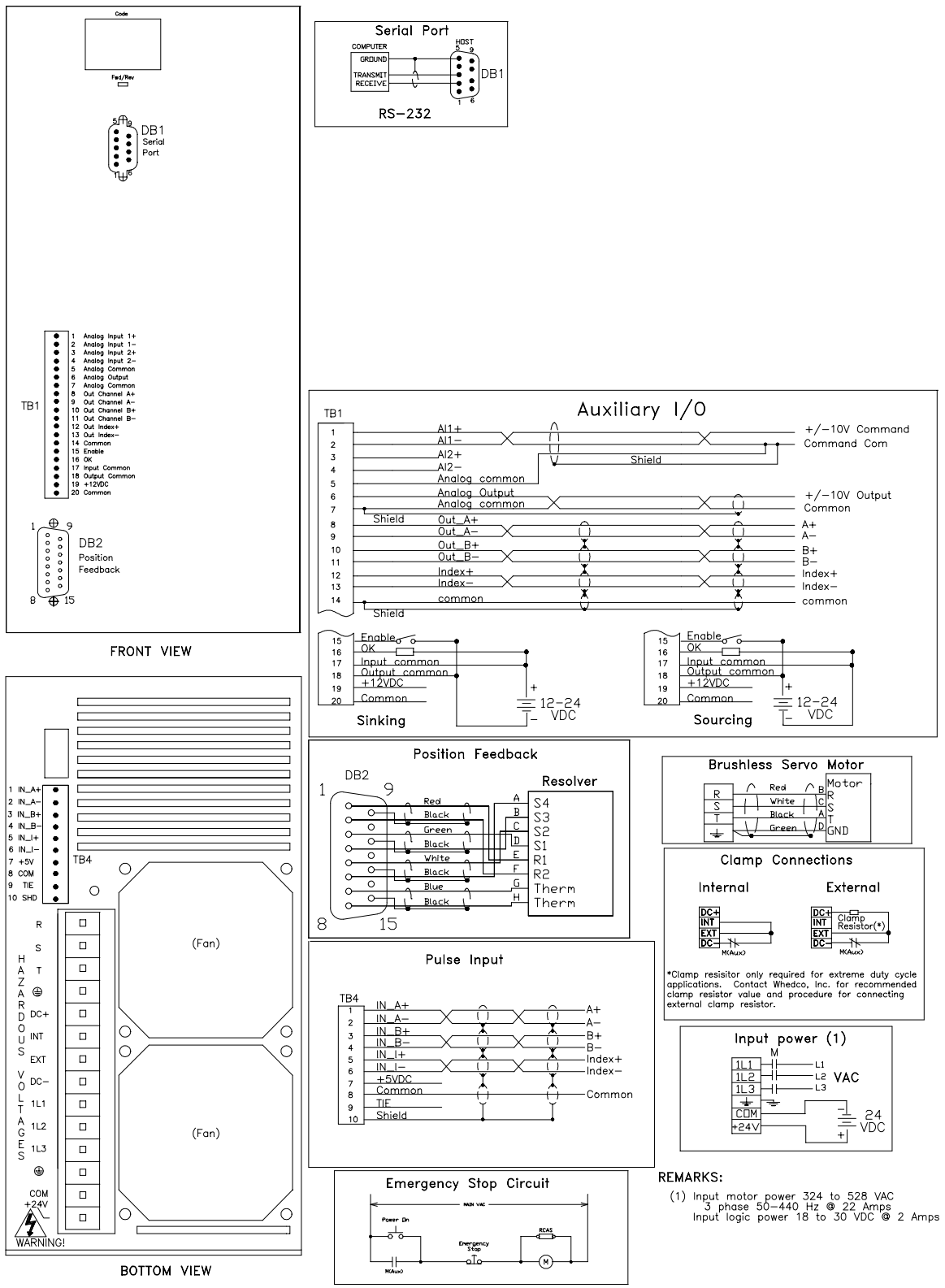

Figure 3-34. Connection Diagram for the 20A 460 VAC Resolver-Based Servo Amplifier (SSD420R)

### 3.6.10 Cables and Connector Mates

Cables in several lengths are available from GE Fanuc for motor to amplifier connections and various other amplifier functions. It is strongly recommended that you use the cables available from GE Fanuc as shown in Table 3-9. GE Fanuc does not ship mating connectors for the MTR-Series motors or S-Series motors along with the motor; however, Table 3-10 shows details for the S-Series motor connector kits that can be separately ordered from GE Fanuc.

**Note:** GE Fanuc cables and connectors shown are not rated for IP67 environments, or washdown applications. GE Fanuc cables are not designed for high flex or cable track applications.

**Table 3-9. Cables Available from GE Fanuc**

S2K Series Cable	GE Fanuc Catalog Number	Description
Aux. I/O Interface	IC800SKCI010	Interface Cable, S2K Auxiliary I/O to 44A726268-001 Terminal Board Assembly, 1 m
	IC800SKCI030	Interface Cable, S2K Auxiliary I/O to 44A726268-001 Terminal Board Assembly, 3 m
	IC800SKCFLY010	Interface Cable, S2K Auxiliary I/O connector to Flying Leads, 1 m
	IC800SKCFLY030	Interface Cable, S2K Auxiliary I/O connector to Flying Leads, 3 m
Serial	IC800SKCS030	S2K Serial Communication Cable for PC (Motion Developer) Interface, 3 m
S-Series Servo Motor Encoder	IC800SKCEZxxx	Encoder Cable, S2K to 30-750 W S-Series Motor, x xx=050 (5 m) or 100 (10 m)
	IC800SKCEVxxx	Encoder Cable, S2K to 1 kW-5 kW S-Series Motor, xxx=050 (5 m) or 100 (10 m)
S-Series Servo Motor Power	IC800SKCPZxxx	Power Cable, S2K to 30 - 750 W S-Series Motor, xxx=050 (5 m) or 100 (10 m)
	IC800SKCPVxxx	Power Cable, S2K to 1 kW-2.5 kW S-Series Motor, xxx=050 (5 m) or 100 (10 m)
	IC800SKCPVLxxx	Power Cable, S2K to 4.5 kW-5 kW S-Series Motor, xxx=050 (5 m) or 100 (10 m)
	IC800SKCBVxxx*	Power/Brake Cable, 1 kW-2.5 kW S-Series Motor with Brake, xxx=050 (5 m) or 100 (10 m)
	IC800SKCBVLxxx*	Power/Brake Cable, 4.5 kW-5 kW S-Series Motor with Brake, xxx=050 (5 m) or 100 (10 m)
S-Series Servo Motor Brake (30-750 W Motors Only)	IC800SLCBZ0xxx	Brake Cable, 30 - 750 W S-Series Motor with Brake, xxx=050 (5 m) or 100 (10 m)
MTR-Series Motor Resolver	CBL-3C-RD-xx	Resolver Cable, S2K to MTR-3N or MTR-3S Series Servo Motor, xx=10, 20 or 30 (feet)
	CBL-3T-RD-xx	Resolver Cable, S2K to MTR-3T Series Servo Motor, xx=10, 20 or 30 (feet)
MTR-Series Motor Power	CBL-34-MP-xx	Power Cable, S2K to MTR-3N Servo Motor, xx=10, 20 or 30 (feet)
	CBL-34-MP-xx	Power Cable, S2K to MTR-3S2x, 3S3x & MTR-3S43-H Servo Motor, xx=10, 20 or 30 (feet)
	CBL-38-MP-xx	Power Cable, S2K to MTR-3S8x Servo Motor, xx=10, 20 or 30 (feet)
	CBL-3C-MP-xx	Power Cable, S2K to MTR-3S43-G, 3S45, 3S46 & 3S6x-G Servo Motor, xx=10, 20 or 30
	CBL-3P-MP-xx	Power Cable, S2K to MTR-3S6x-H Servo Motor, xx=10, 20 or 30 (feet)
	CBL-3T-MP-xx	Power Cable, S2K to MTR-3T4x, 3T5x & 3T6x Servo Motor, xx=10, 20 or 30 (feet)
	CBL-T7-MP-xx	Power Cable, S2K to MTR-3T1x & 3T2x Servo Motor, xx=10, 20 or 30 (feet)
MTR-Series Motor Brake	CBL-3T-MB-xx	Power/Brake Cable, S2K to MTR-3T4x, 3T5x & 3T6x Servo Motor with Brake, xx=10, 20 or 30 (feet)
	CBL-T7-MB-xx	Power/Brake Cable, S2K to MTR-3T1x & 3T2x Series Servo Motor with Brake, xx=10, 20 or 30 (feet)
	CBL-30-BT-xx	Brake Cable, S2K to MTR-3N & 3S Series Servo Motor with Brake, xx=10, 20 or 30 (feet)

\*The 1kW-5kW S-Series servo motors incorporate the brake power and motor power into a single cable. When a brake is required this cable should be used in place of the motor power cable IC800SKCPVxxx or IC800SKCPVLxxx. The 30-750W S-Series servo motors require a separate cable (IC800SLCBZxxx) for motor brake power when the brake option is required.

Table 3-10. S-Series Servo Motor Connector Mates

Connector Kit	Connector Function	Qty	Connector Description	Connector Part Number	Manufacturer
IC800SLMCONKITZ 30 to 750 Watt S-Series Motors without Brake	Encoder	1	Socket	172163-1	AMP, Inc. or equivalent
		15	Contact	794058-3 or 770834-3	
	Power	1	Socket	172159-1	
		4	Contact	170366-1 or 170362-1	
IC800SLMCONKITZB 30 to 750 Watt S-Series Motors with Brake	Encoder	1	Socket	172163-1	AMP, Inc. or equivalent
		15	Contact	794058-3 or 770834-3	
	Power	1	Socket	172159-1	
		4	Contact	170366-1 or 170362-1	
	Brake	1	Socket	172157-1	
		2	Contact	170366-1 or 170362-1	
IC800SLMCONKITV 1000 to 2500 Watt S-Series Motors without Brake	Encoder	1	MS-Shell*	MS3106B20-29S	Amphenol or equivalent
		1	Cable Clamp	MS3057-12A (97-3057-1012)	
		1	Bushing	3420-12 (9779-513-12)	
	Power (No Brake)	1	MS-Shell*	MS3106B20-4S	
		1	Cable Clamp	MS3057-12A (97-3057-1012)	
		1	Bushing	3420-12 (9779-513-12)	
IC800SLMCONKITVB 1000 to 2500 Watt S-Series Motors with Brake	Encoder	1	MS-Shell*	MS3106B20-29S	Amphenol or equivalent
		1	Cable Clamp	MS3057-12A (97-3057-1012)	
		1	Bushing	3420-12 (9779-513-12)	
	Power & Brake	1	MS-Shell*	MS3106B20-18S	
		1	Cable Clamp	MS3057-12A (97-3057-1012)	
		1	Bushing	3420-12 (9779-513-12)	
IC800SLMCONKITVL 3500 to 5000 Watt S-Series Motors without Brake	Encoder	1	MS-Shell*	MS3106B20-29S	Amphenol or equivalent
		1	Cable Clamp	MS3057-12A (97-3057-1012)	
		1	Bushing	3420-12 (9779-513-12)	
	Power (No Brake)	1	MS-Shell*	MS3106B22-22S	
		1	Cable Clamp	MS3057-12A (97-3057-1012)	
		1	Bushing	3420-12 (9779-513-12)	
IC800SLMCONKITVLB 3500 to 5000 Watt S-Series Motors with Brake	Encoder	1	MS-Shell*	MS3106B20-29S	Amphenol or equivalent
		1	Cable Clamp	MS3057-12A (97-3057-1012)	
		1	Bushing	3420-12 (9779-513-12)	
	Power & Brake	1	MS-Shell*	MS3106B24-11S	
		1	Cable Clamp	MS3057-16A (97-3057-1016)	
		1	Bushing	3420-16 (9779-513-16)	

\* The connector shells shown for the 1-5 kW model servo motors are for straight mating connectors. For right angle connectors substitute MS3108 for MS3106 in the part number.

## 3.7 Wiring The Optional Motor Brake

The following figure shows a typical wiring example for the optional S-Series and MTR-Series servo motor holding brake. The brake must be energized using a 24 VDC power supply to release its hold on the motor. Chapter 2 contains motor brake specifications showing the current requirements for each model motor. GE Fanuc offers a 24 VDC, 5 amp DIN-rail mounted power supply (Part Number IC690PWR024) that may be used. If the brake control contact is rated for switching the inductive load of the Motor Brake Coil, the control relay (CR1) may not be required.

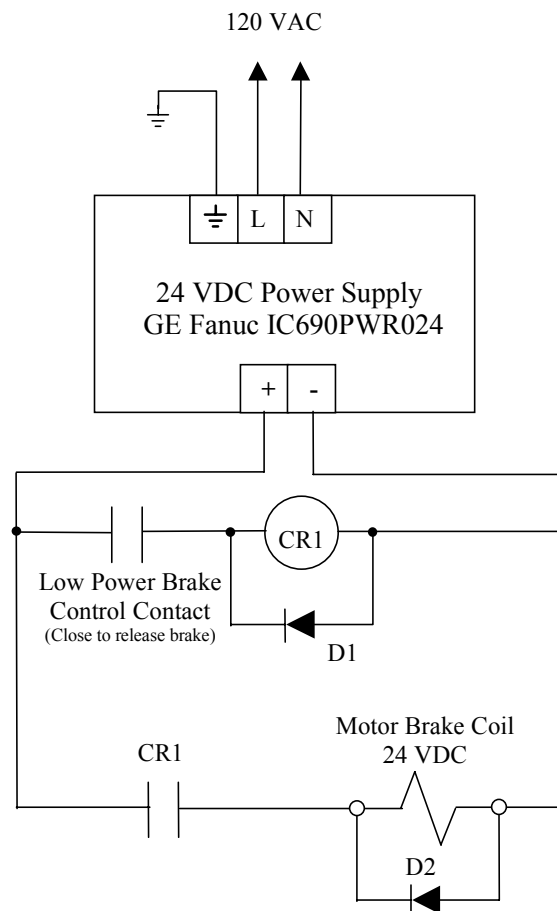

### Customer Supplied Components:

- CR1 – Control relay, Coil: 24 VDC/50mA or less,  
Contact: rated for 1Amp DC continuous and break
- D1 – Diode, 1A, 100 VDC, 1N4002 or equivalent
- D2 – Diode, 3A, 100 VDC, 1N5401 or equivalent

Figure 3-35. Typical Brake Wiring Diagram

## 3.8 Regenerative Discharge Resistor Selection and Wiring

Regenerative energy is normally created in applications with a high load inertia, high speed, vertical axes and/or frequent acceleration and deceleration. When decelerating a load, the stored kinetic energy of the load creates generator action in the motor causing energy to be returned to the servo amplifier. For light loads and low acceleration rates, the amplifier may be able to absorb and store this energy in the DC link filter capacitors or dissipate it in an internal regenerative resistor. Otherwise, an optional external regenerative discharge unit must be installed.

The S2K Series amplifiers include an internal regenerative discharge resistor that will control the regenerative energy in most applications. When an Over Voltage fault (LED Status Code OV) or an Excessive Clamp Duty Cycle fault (LED Status Code EC) occurs during motor deceleration, the cause is usually excessive regeneration and requires an optional external regenerative resistor kit. The SSD104 amplifier has no provisions for connecting an external resistor. As an alternative to adding an external resistor you can try a combination of the following actions:

- Reduce the deceleration rate and/or increase deceleration time
- Lower the top speed of the motor
- Reduce machine cycle rate
- Reduce load inertia connected to the motor
- Increase vertical axis counterbalance

GE Fanuc offers several different resistor kits (all kits include resistor mounting brackets) as shown in Table 3-11. Wiring between the resistor and the amplifier's power terminals is not included in the kit and is the user's responsibility. Connections to the resistor can be made by soldering, using a fast-on type terminal of appropriate size, or using a ring terminal bolted through the hole in the resistor terminal tab. See Figure 3-36.

### Caution

**Under normal operation the regenerative discharge resistor may become very hot. To prevent being burned, never touch the resistor. Mount the resistor well away from heat sensitive components or wiring to prevent damage. Also, the terminals of this resistor are at a high voltage potential. Either insulate the connections or provide adequate shielding to eliminate this shock hazard.**

**Table 3-11. Regenerative Discharge Resistor Kits**

GE Fanuc Regenerative Discharge Resistor Kits	Resistor Kit Specifications			
	Resistance	Continuous Power <sup>1</sup>	Peak Power for 230 VAC Models <sup>2</sup>	Peak Power for 460 VAC Models <sup>2</sup>
IC800SLR001	50 $\Omega$	100 W	3362 W	13612
IC800SLR002	100 $\Omega$	225 W	1681 W	6806
IC800SLR003	20 $\Omega$	300 W	8405 W	34031
IC800SLR004	15 $\Omega$	1000 W	11207 W	45375

1) Resistor continuous power ratings are at 25°C ambient temperature. Derate power linearly at 0.3% per °C above 25°C.

2) Peak power is based on an average discharge circuit turn-on voltage of 410 VDC for models rated 230 VAC and 825 VDC for models rated 460 VAC.

The resistor values included with the kits are average values for a variety of conditions. Smaller capacity (wattage) resistors may work in some applications and larger resistors may be required in others. The lower the resistance value, the faster the regenerative energy can be dissipated. Applications with large inertial loads, high speeds, and high deceleration rates regenerate more energy and may require a resistor with a lower resistance and/or larger capacity (wattage). As an alternative, when the capacity or resistance of the standard external regenerative resistor is insufficient for the application, reducing load inertia, maximum speed, deceleration rate, increasing vertical axis counterbalance or some combination of these measures can decrease the regenerative energy. See Section 3.8.1 for details on selecting the proper resistor based on application requirements.

The wiring between the amplifier and the regenerative resistor should be kept as short as possible (less than 20 inches or 50cm) to prevent possible damage to the switching transistor from voltage transients due to cable inductance. The regenerative resistor may become very hot during normal operation. Therefore, route all wiring away from the resistor so that the wiring does not touch the resistor and has a minimum clearance of 3 inches (76mm).

Connect one terminal of the resistor to the amplifier's "EXT" power terminal and the other resistor terminal to the "DC+" amplifier power terminal. See Figures 3-30 and 3-34.

**Note:** If you are not using an external resistor, a wire jumper must be connected between the power terminals "INT" and "EXT" as shown in the "Clamp Connections-External" section of Figures 3-30 and 3-34. If this jumper is not installed, the internal resistor is disabled and the amplifier may exhibit symptoms associated with excessive regeneration. This note does not apply to the SSD104 model amplifier.

When mounting the resistor, tighten the lock nut sufficiently to compress the lock washer. Although the lock nut should be tightened securely, avoid over-tightening so as not to strip the bolt threads.

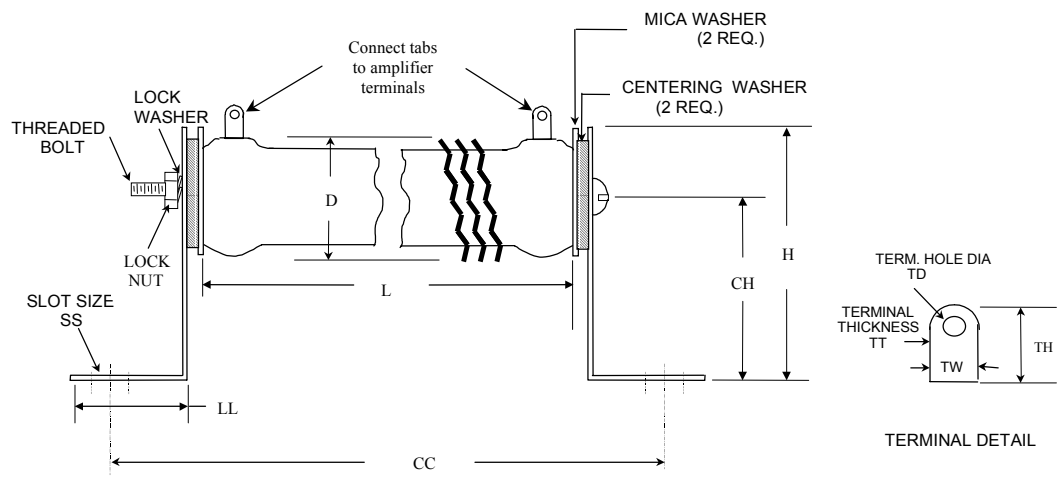

Part Number	Dimensions (in inches)										
	Resistor		Bracket					Terminal			
	L +/- .062	D Max.	H	CH	CC	LL	SS	TH	TW	TT	TD
IC800SLR001	6.50	.910	1.75	1.25	7.562	.750	.218 X.437	.562	.250	.020	.166
IC800SLR002	10.5	1.312	2.13	1.5	11.562	.875	.281 X.562	.625	.375	.020	.173
IC800SLR003	8.5	1.125	1.75	1.25	9.562	.750	.218 X.437	.625	.375	.020	.173
IC800SLR004	15	2.50	4.25	3.0	17.0	1.25	.281 X.562	.625	.500	.025	.188

Figure 3-36. Regenerative Discharge Resistor Mounting and Wiring Dimensions

### 3.8.1 Calculating Regenerative Power and Selecting a Resistor

Use the following calculation to determine the average regenerative power that will be released in your application. These calculations ignore any losses due to resistance in the motor armature and lead wire. Based on the calculations, select the appropriate regeneration resistor kit from Table 3-11. The continuous power rating of the selected resistor must **exceed** the average calculated regenerative power from the equation below:

$$\begin{array}{rclcl}
 \text{Average} & & \text{Rotational Energy} & & \text{Energy to be} & & \text{(only in vertical axis operation)} \\
 \text{Regenerative} & = & \text{to be Released} & - & \text{Consumed} & + & \text{Vertical Axis Energy to be} \\
 \text{Energy} & & \text{during} & & \text{Through Axis} & & \text{Released During Downward} \\
 \text{(Joules)} & & \text{Deceleration} & & \text{Friction} & & \text{Motion} \\
 & & \text{(STEP 1)} & & \text{(STEP 2)} & & \text{(STEP 3)}
 \end{array}$$

**STEP 1: Rotational Energy to be Released During Deceleration (E<sub>d</sub>)**

$$E_d = (6.19 \times 10^{-4}) \times (J_m + J_L) \times (\omega_i^2 - \omega_f^2) \quad \text{Joules}$$

Where:

- J<sub>m</sub> Motor rotor inertia (lb-in-s<sup>2</sup>)  
(See Motor Specification table in Chapter 2)
- J<sub>L</sub> Load inertia reflected to motor shaft (lb-in-s<sup>2</sup>)
- ω<sub>i</sub> Initial motor speed at the beginning of deceleration (RPM)
- ω<sub>f</sub> Final motor speed at the end of deceleration (RPM)

This step must be calculated for each deceleration in the motion profile and then the values summed to arrive at a total regenerated energy for this step. For multi-speed (compound) moves, the starting and ending velocity must be used for ω<sub>i</sub> and ω<sub>f</sub> for each deceleration segment.

**STEP 2: Energy to be Consumed Through Axis Friction (E<sub>f</sub>)**

$$E_f = (5.91 \times 10^{-3}) \times t_a \times (\omega_i - \omega_f) \times T_f \quad \text{Joules}$$

Where:

- ω<sub>i</sub> Initial motor speed at the beginning of deceleration (RPM)
- ω<sub>f</sub> Final motor speed at the end of deceleration (RPM)
- t<sub>a</sub> Deceleration time (Sec)
- T<sub>f</sub> Axis friction torque (as seen by the motor) (in-lb)

This step must be calculated for each deceleration in the motion profile and then the values summed to arrive at a total regenerated energy for this step. For multi-speed (compound) moves the starting and ending velocity must be used for ω<sub>i</sub> and ω<sub>f</sub> for each deceleration segment.

**STEP 3: Vertical Axis Energy to be Released During Downward Motion (E<sub>v</sub>)**

(This term applies only in vertical axis operation)

$$E_v = (1.182 \times 10^{-2}) \times T_h \times \omega_m \times t_d \text{ Joules}$$

where:

- T<sub>h</sub>    Upward supporting torque applied by the motor during downward rapid traverse to hold the load against gravity    (in-lb)
- t<sub>d</sub>    Time of downward motion    (Sec)
- ω<sub>m</sub>    Motor speed during downward rapid traverse    (RPM)

**STEP 4: Determine if an External Regenerative Discharge Resistor Is Required**

Determine the *Average Regenerative Energy* using the equation in the beginning of this section. To compare this to the regenerative capacity of the amplifier, you must first perform the following calculations:

- a) Account for the energy stored in the DC link filter capacitors:

Net Energy = Average Regenerative Energy – Capacitor Energy Storage (from Table 3-12)

- b) Convert the Net Energy to Average Regenerative Power using the equation below:

$$\text{Average Regenerative Power (Watts)} = \text{Net Regenerative Energy (Joules)} \times \frac{1}{T}$$

where:

T = Total profile cycle time (seconds)

If the *Average Regenerative Power* exceeds the *Maximum Continuous Power* indicated in Table 3-12 for the amplifier you are using, an external regenerative discharge resistor is required:

**Table 3-12. Amplifier Regenerative Discharge Ratings**

Amplifier Model	Rating	Capacitor Energy Storage *	Min. External Resistance	Internal Resistor Ratings	
				Resistance	Max. Continuous Power
SSD104	4.3 Amp, 115/230 VAC	17.5 Joules	N/A	50 Ω	39 Watts
SSD107	7.2 Amp, 115/230 VAC	34.9 Joules	50 Ω	50 Ω	24 Watts
SSD216	16 Amp, 230 VAC	69.8 Joules	25 Ω	25 Ω	95 Watts
SSD228	28 Amp, 230 VAC	104.7 Joules	12 Ω	12.5 Ω	189 Watts
SSD407	7.2 Amp, 460 VAC	84.9 Joules	50 Ω	50 Ω	48 Watts
SSD420	20 Amp, 460 VAC	255 Joules	25 Ω	25 Ω	193 Watts

\*Assumes nominal AC line voltage of 230 VAC. High line voltage will dramatically reduce the amount of regenerated energy the amplifier capacitors can absorb (for example, a 10% high line voltage will reduce the maximum regenerated energy to 43% of the values shown).

If the calculated value exceeds the storage capability of the amplifier, then an external regenerative resistor is required (see Step 5).

### STEP 5: Selecting a Regenerative Discharge Resistor Kit

If an external regenerative resistor kit is required it must meet the following criteria:

1. The resistance of the selected resistor must exceed the *Minimum External Resistance* value shown in Table 3-9 for your specific amplifier.
2. The value calculated for the *Average Regenerative Power* must be **less** than the *Continuous Power* rating shown in Table 3-8 for the selected resistor kit.

Contact GE Fanuc if you require assistance in selecting the appropriate value.

### STEP 6: Determine the Peak Power Requirements for the Resistor

The peak power determines the maximum rate at which the regenerated energy must be dissipated to prevent overvoltage faults on the amplifier. The peak power must be calculated for each deceleration period of the profile by dividing the regenerated energy for that period by the time over which the energy is released.

Peak Power = Regenerated Energy/ Regeneration Time

This value must be lower than the *Peak Power* rating for the resistor selected (see Table 3-11). If a non-standard resistor is substituted, its peak power can be calculated as follows:

$$230 \text{ VAC Models Peak Power} = 410^2 / R \quad \text{Watts}$$

$$460 \text{ VAC Models Peak Power} = 825^2 / R \quad \text{Watts}$$

where R is the resistance value in ohms for the selected resistor.

### Regeneration Application Example:

Assume a vertical axis using an SLM100 motor ( $J_m = 0.001491 \text{ lb-in-s}^2$ ) with a load inertia ( $J_L$ ) of  $0.0139 \text{ lb-in-s}^2$ . The SLM100 motor uses an SSD107 amplifier. The friction torque in the axis ( $T_f$ ) is 10 in-lb and the torque that is required to support the load against gravity ( $T_h$ ) is 15 in-lb. The axis requires the following compound velocity profile:

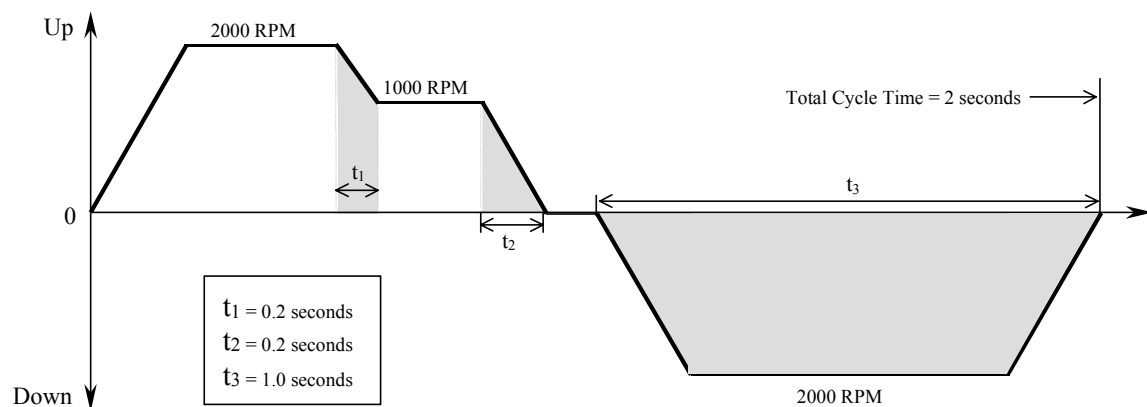

Since the example machine cycle involves a number of periods where regeneration occurs, the determination of the regenerated energy is more complicated. Regeneration occurs for each deceleration period when the axis is moving in the upward direction (against gravity) and during the period when the axis is moving in the downward direction. These areas are shaded in the profile shown above. The regeneration for each of these periods must be calculated as follows:

**STEP 1a:** Calculate the rotational energy during period  $t_1$ :

$$E_{d1} = (6.19 \times 10^{-4}) \times (0.001491 + 0.0139) \times (2000^2 - 1000^2) = 28.58 \text{ Joules}$$

**STEP 1b:** Calculate the rotational energy during period  $t_2$ :

$$E_{d2} = (6.19 \times 10^{-4}) \times (0.001491 + 0.0139) \times (1000^2 - 0^2) = 9.53 \text{ Joules}$$

**STEP 2a:** Calculate the energy absorbed by friction during period  $t_1$ :

$$E_{f1} = (5.91 \times 10^{-3}) \times 0.2 \text{ sec} \times (2000 \text{ RPM} - 1000 \text{ RPM}) \times 10 \text{ in-lb} = 11.82 \text{ Joules}$$

**STEP 2b:** Calculate the energy absorbed by friction during period  $t_2$ :

$$E_{f2} = (5.91 \times 10^{-3}) \times 0.2 \text{ sec} \times 1000 \text{ RPM} \times 10 \text{ in-lb} = 11.82 \text{ Joules}$$

**STEP 3:** Calculate the regenerative energy for downward motion during period  $t_3$ :

$$E_v = (1.182 \times 10^{-2}) \times 15 \text{ in-lb} \times 2000 \text{ RPM} \times 1 \text{ Sec} = 354.6 \text{ Joules}$$

**STEP 4:** Calculate the *Average Regenerative Energy* for the entire cycle ( $E_{avg}$ ):

$$E_{avg} = 28.58 + 9.53 - 11.82 - 11.82 + 354.6 = 369.1 \text{ Joules}$$

To determine if the SSD107 amplifier can absorb this amount of energy, first determine the net energy the regeneration resistors must dissipate. To find this Net Energy value, subtract the energy stored in the amplifiers bus filter capacitors as shown under the *Capacitor Energy Storage* heading in Table 3-12.

$$\text{Net Energy} = 369.1 \text{ Joules} - 41.1 \text{ Joules} = 328 \text{ Joules}$$

Next, we must convert this Net Energy to power so we can compare the result with the dissipation capability of the amplifier's internal regeneration resistor.

$$\text{Average Power} = \text{Net Energy} / \text{Total Cycle Time} = 328 / 2 \text{ Sec} = 164 \text{ Watts}$$

We now compare this result to the amplifier's Max. Continuous Power rating from Table 3-12. Since the 164 Watts required is more than the 25 watts allowed by the SSD107 amplifier, an external regenerative resistor **is** required.

**STEP 5:** Determine the proper external regeneration resistor size:

If we refer to the resistor selection criteria shown in Step 5 above, we must first select a resistor that has a resistance value larger than the *Min. External Resistance* for the SSD107 amplifier shown in Table 3-9. Therefore, our resistor must be at least 50  $\Omega$ . From the second criteria our calculated value of 164 Watts for the *Average Regenerative Power* must be **less** than the *Continuous Power* rating of the resistor we select.

From Table 3-11 we see that resistor kit IC800SLR002 has a resistance of 100 $\Omega$  and a continuous power rating of 225 Watts which meets both of the selection criteria.

**STEP 6:** Check the peak power ( $P_{pk}$ ) requirements for each regeneration period:

$$\text{For period } t_1: P_{pk1} = 28.58 \text{ Joules} / 0.2 \text{ seconds} = 142.9 \text{ Watts}$$

$$\text{For period } t_2: P_{pk2} = 9.53 \text{ Joules} / 0.2 \text{ seconds} = 47.65 \text{ Watts}$$

$$\text{For period } t_3: P_{pk3} = 369.1 \text{ Joules} / 1 \text{ second} = 369.1 \text{ Watts}$$

The largest of these values, 369.1 Watts, is still less than the 2880 Watt *Peak Power* rating of the IC800SLR001 resistor kit so this standard resistor can be used.

## 3.9 Dynamic Braking Contact and Operation

For amplifier models SSD216, SSD228 and SSD420 it is possible to configure a dynamic braking (DB) function that will use the internal regeneration resistor to dynamically brake the motor when power is removed from the amplifier. The DB function requires a normally closed auxiliary contact from the main AC line contact that feeds power to the amplifier. This contact (Maux) must be wired between the “EXT” and “INT” power terminals as shown in the section titled “Clamp Connections” on Figures 3-31, 3-32 and 3-34.

For the other controller models it is necessary to use an external dynamic brake circuit as shown in the diagram below. The resistor value should be approximately equal to the motor armature resistance.

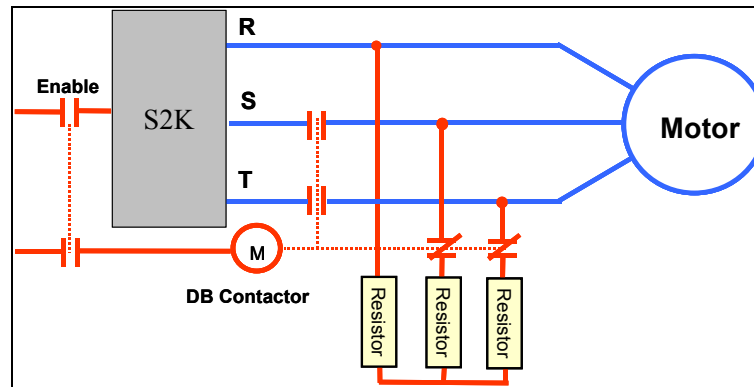

Figure 3-37. Typical External Dynamic Brake Circuit

# Chapter 4

## Getting Started

---

---

This chapter documents the process for completing a basic setup for an S2K amplifier for the various modes of operation. Various software parameters can be configured which allow you to configure the amplifier for your application requirements. Chapter 5 includes a detailed reference for the software commands and registers supported by the S2K Series amplifiers.

This chapter assumes that the amplifier power, motor power, and motor encoder have been wired correctly according to the guideline in Chapter 3, and that power is applied. The motor should not be connected to a load until the basic setup has been completed.

### 4.1 Establishing Communications

In order to configure the amplifier software setting, you must first establish communications with the amplifier using a VT100-compliant terminal emulation program. The Windows<sup>®</sup> Hyper Terminal or the Terminal window in GE Fanuc's Motion Developer software are two that will be discussed in this manual. When using a third party terminal program you must prefix each line with a node address between 0 and 9. This is not required when using the Motion Developer terminal window.

#### 4.1.1 Connect The Serial Cable

The first step is to connect the serial cable between the serial communication port on your PC and the amplifier's *Serial Port* connector. GE Fanuc offers a prefabricated cable (part number IC800SKCS020) or you can make your own (see Chapter 3 for wiring details). Tighten the screws to fasten the connector.

#### 4.1.2 Start The Terminal Emulation Software

The next step is to start the terminal emulation software you wish to use. The following sections will discuss using the Window's Hyper Terminal and Motion Developer.

---

<sup>®</sup> Windows is a registered trademark of Microsoft, Incorporated

### 4.1.2.1 Using Hyper Terminal

In the Windows Start menu, select the Hyper Terminal option or search for the file called Hypertrm.exe to open the terminal software. The main window looks like the screen below.

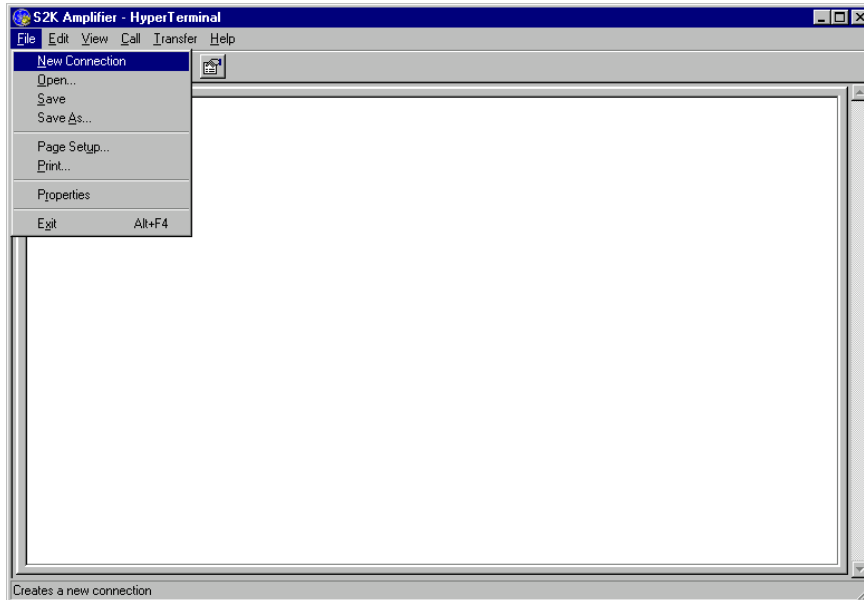

From the *File* menu, select *New Connection* and the *Connection Description* screen will be displayed.

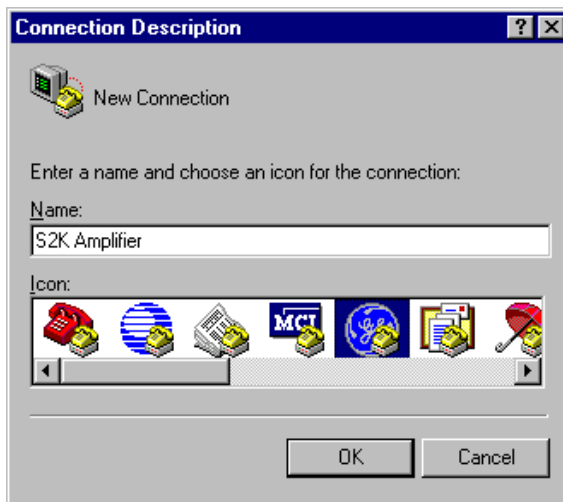

Select an icon from the scrolled list and enter a name for the connection (the example uses S2K Amplifier). Click the *OK* button.

The Phone Number screen should be displayed as shown below. On this screen, in the *Connect Using* list box, you must select the serial port associated with the physical port where you connected your serial cable to the amplifier. Our example uses the *Direct to Com 1* option. Click the *OK* button.



The COM1 Properties box will appear next. Configure the settings for the COM port as shown in the example below and then click OK.

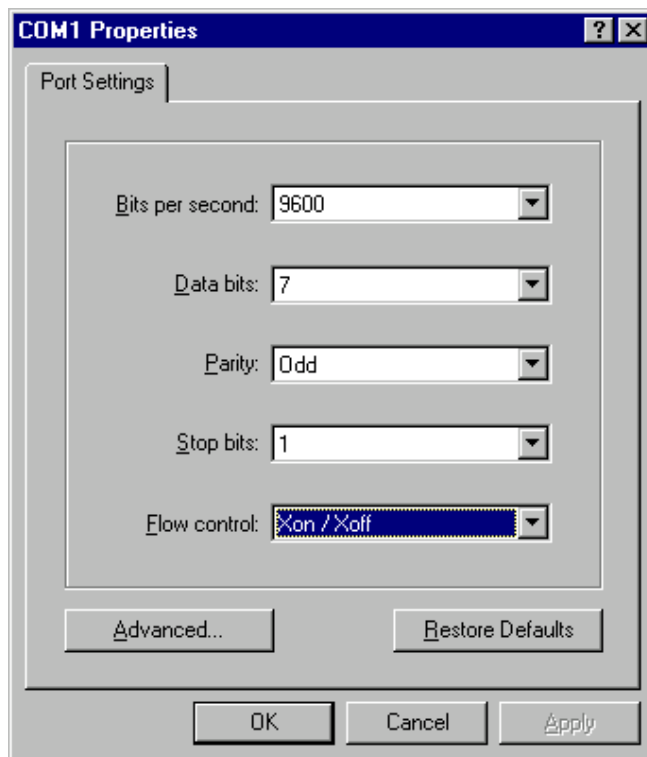

You will be returned to the main Hyper Terminal screen. You must now configure the properties of the connection by selecting Properties from the File menu as shown below:

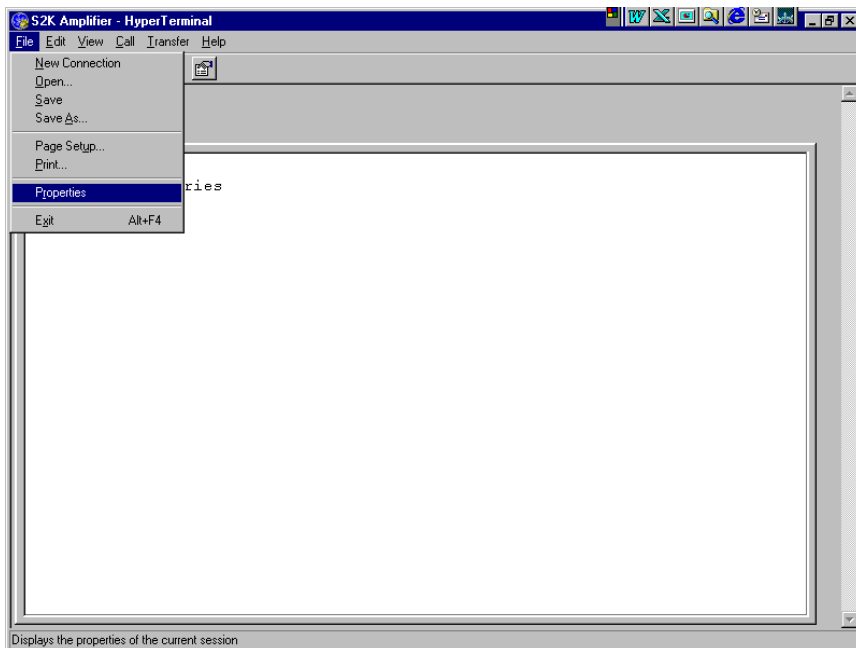

The Properties dialog box will be displayed as shown below. In the emulation list box, select VT100 and then click the OK button.

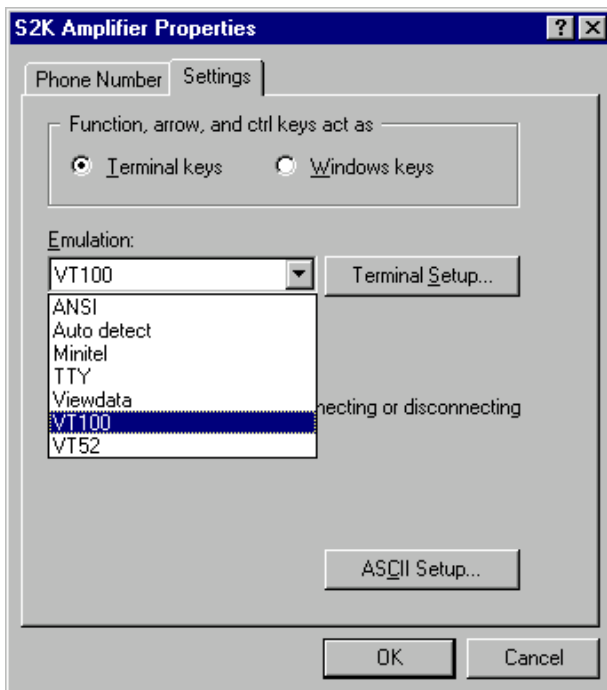

You are now in the main terminal window and should be properly connected to the amplifier. Press the Enter key on your keyboard several times and the "INVALID COMMAND" prompt should be displayed on the screen as shown below.

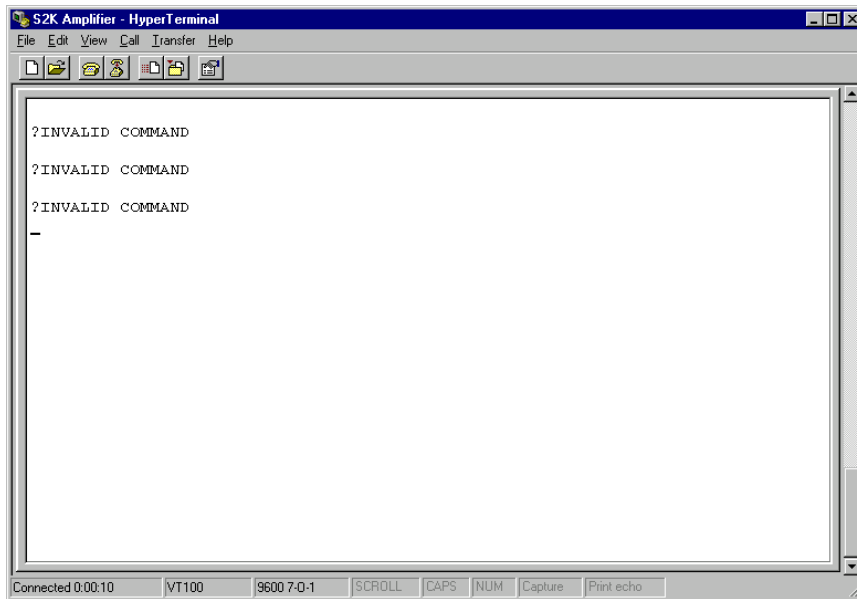

If this prompt does not appear, then you are not communicating with the amplifier. Make sure your serial cable is properly connected, the Hyper Terminal connection properties are correct, and AC power has been applied to the amplifier.

The INVALID COMMAND message is displayed because the S2K amplifier is expecting a node address as a prefix to the terminal command. Any digit between 0 and 9 will work and no space is required as a separator from the command text. In the terminal, type 1 and then press the <ENTER> key, and the “GE Fanuc S2K Series” prompt should be displayed.

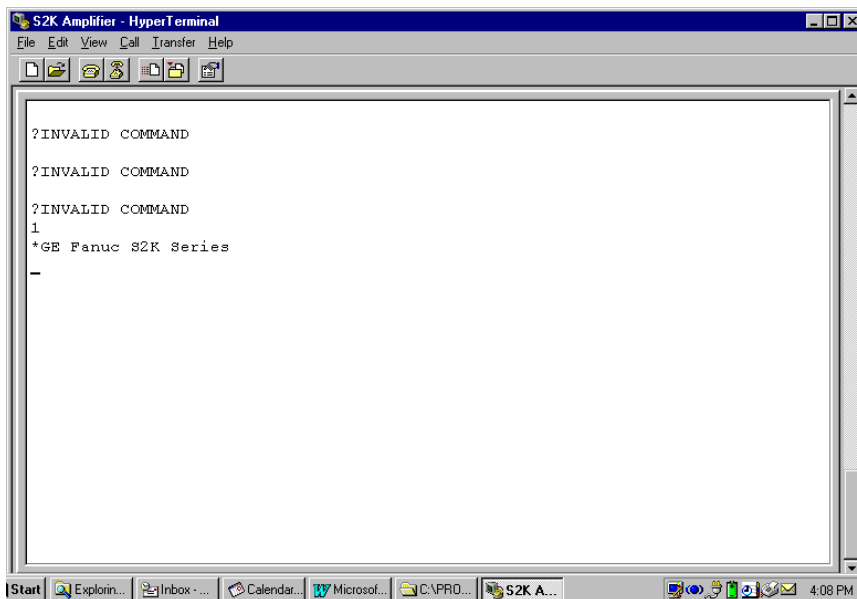

Next, try to query the contents of the Fault Code register (FC) using the query command (Q or ?). In the terminal window, type 1FC? and then press the <Enter> key. The Lost Enable and Power Failure messages should be displayed as shown below. This is normal since the Enable digital input is not yet connected and the power failure fault is present each time the amplifier is energized.

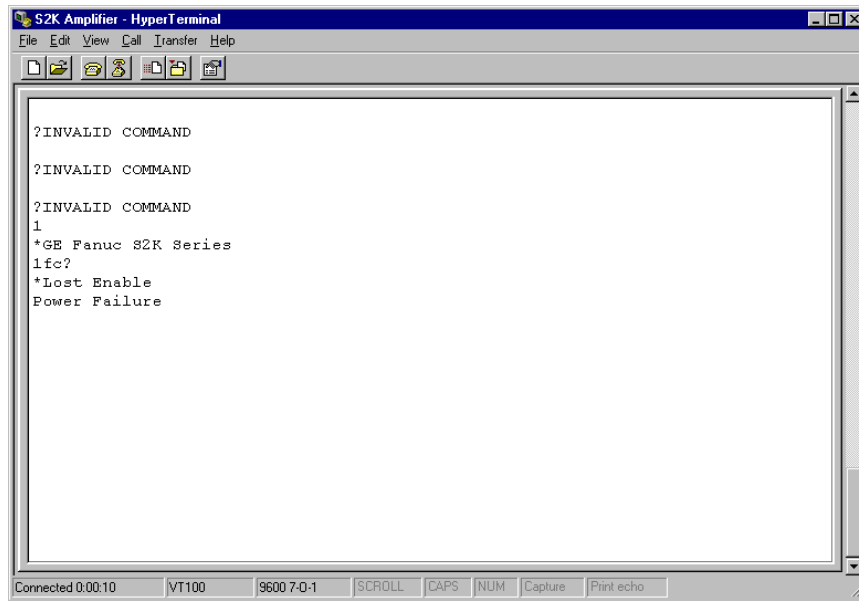

```
?INVALID COMMAND
?INVALID COMMAND
?INVALID COMMAND
1
*GE Fanuc S2K Series
1fc?
*Lost Enable
Power Failure
```

Congratulations, you have successfully established communications with the amplifier and are ready to move on to Configuring the Operating Mode.

### 4.1.2.2 Using Motion Developer

The Motion Developer software primarily supports the S2K Series motion controller models, but the terminal window also can be used to configure and troubleshoot the S2K amplifier models. Appendix B reviews the installation and registration for this software. If you have not yet installed the software, please refer to Appendix B before proceeding with this section.

### Software Introduction

Motion Developer software runs inside the GE Fanuc CIMPLICITY Machine Edition environment. Those using additional Machine Edition applications will appreciate the benefits and convenience of using this one common programming environment. For the S2K amplifier only models, the terminal window is the only feature required. Therefore, many of the optional windows are not used and can be turned off as described in this section.

## Setting up the Motion Developer Screen

The Motion screen shown below appears with most of the optional windows open.

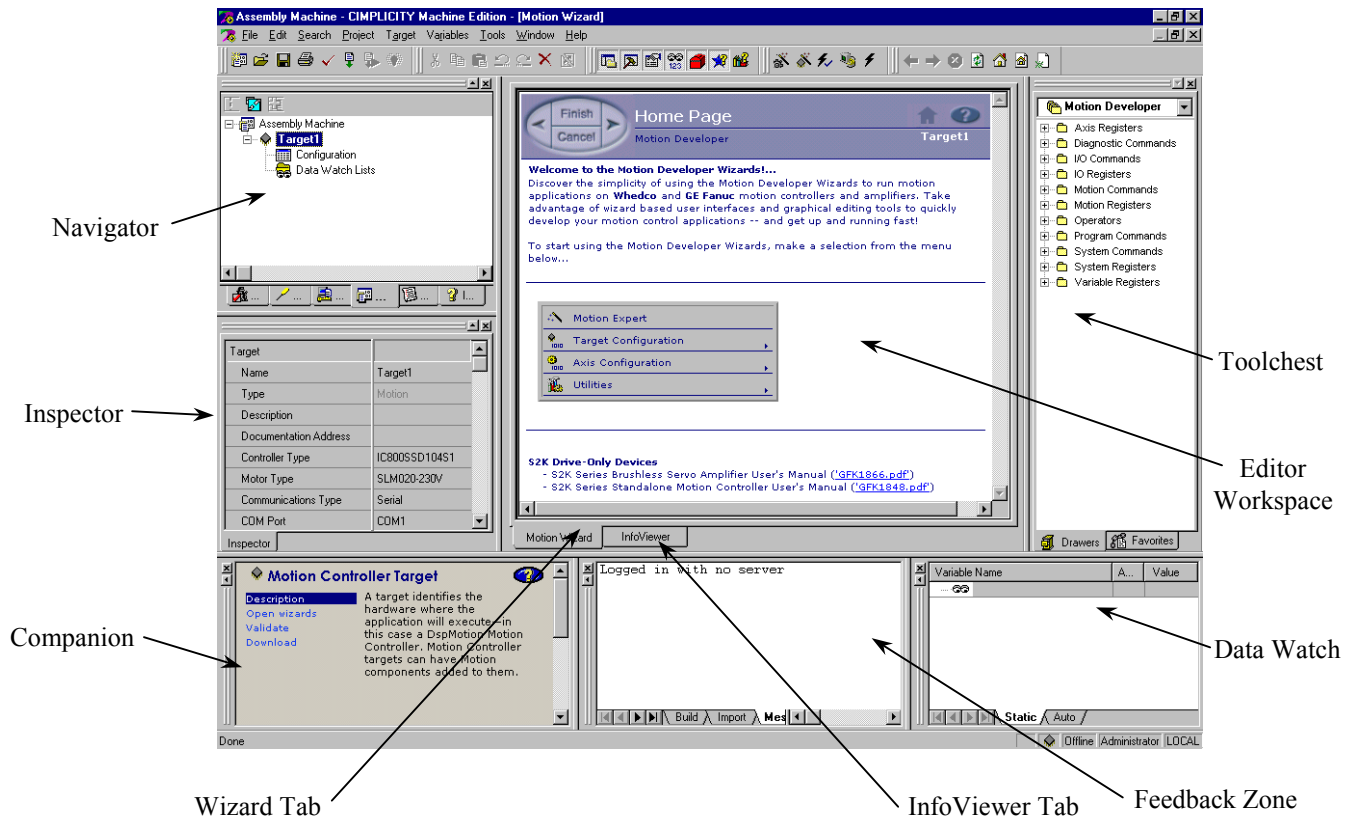

You will probably want to turn most of the individual windows off since they are not used for the S2K amplifier-only models. Keep only the Navigator and Inspector windows open.

To close the windows you do not want to display simply click the appropriate toolbar buttons or use the keyboard hot keys as shown below:

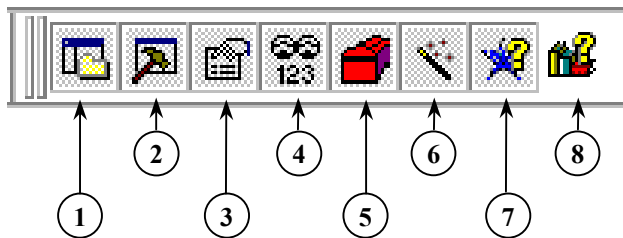

- |                               |                             |
|-------------------------------|-----------------------------|
| 1. Navigator (Shift + F4)     | 5. Toolchest (Shift + F9)   |
| 2. Feedback Zone (Shift + F6) | 6. Wizard (Shift + F10)     |
| 3. Inspector (Shift + F7)     | 7. Companion (Shift + F11)  |
| 4. Data Watch (Shift + F8)    | 8. InfoViewer (Shift + F12) |

To access the Motion Developer terminal window, you must first create a new project as follows.

## Creating a New Project

Click the Manager tab on the Navigator window. The Navigator window will display the Manager file structure.

Right-click *My Computer* and choose *New Project* from the drop-down menu. The “New Project” window will appear. See next figure.

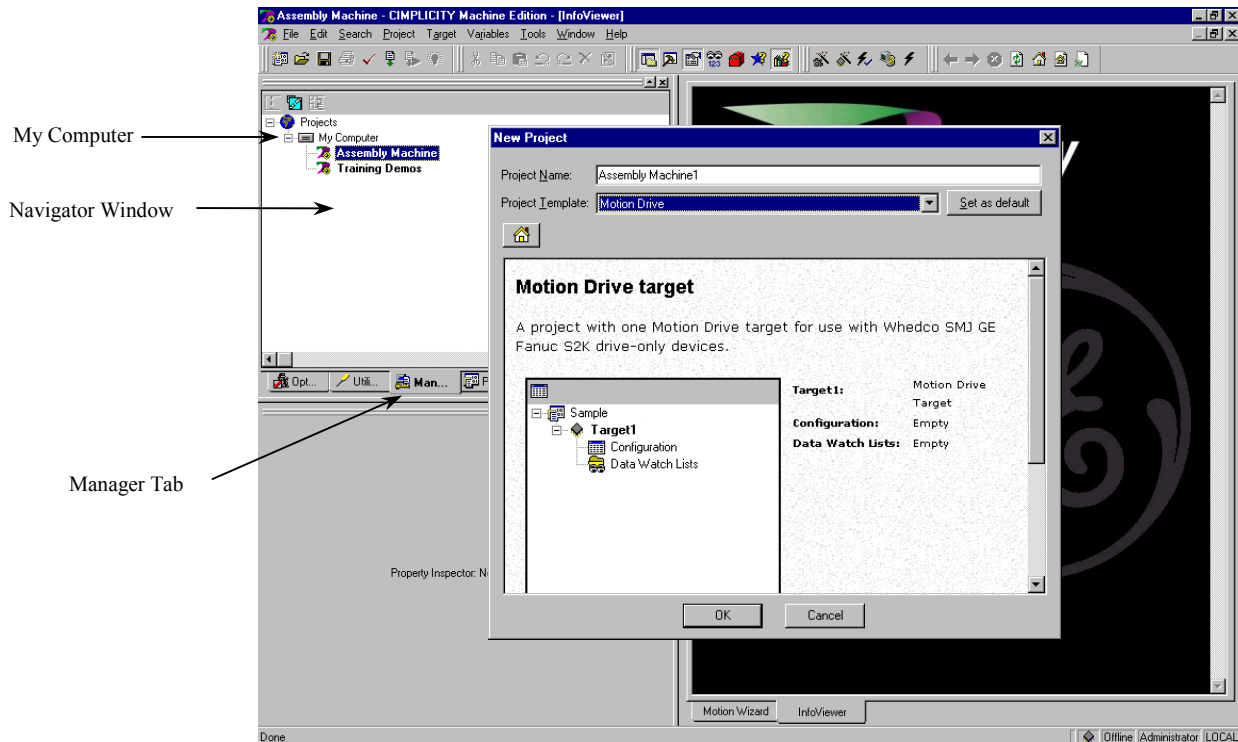

Enter the name of your project, then click the OK button. The “Motion Developer Wizards” window will appear, shown in the next figure. Do not click any of the options on this window. They apply only to the S2K controller models.

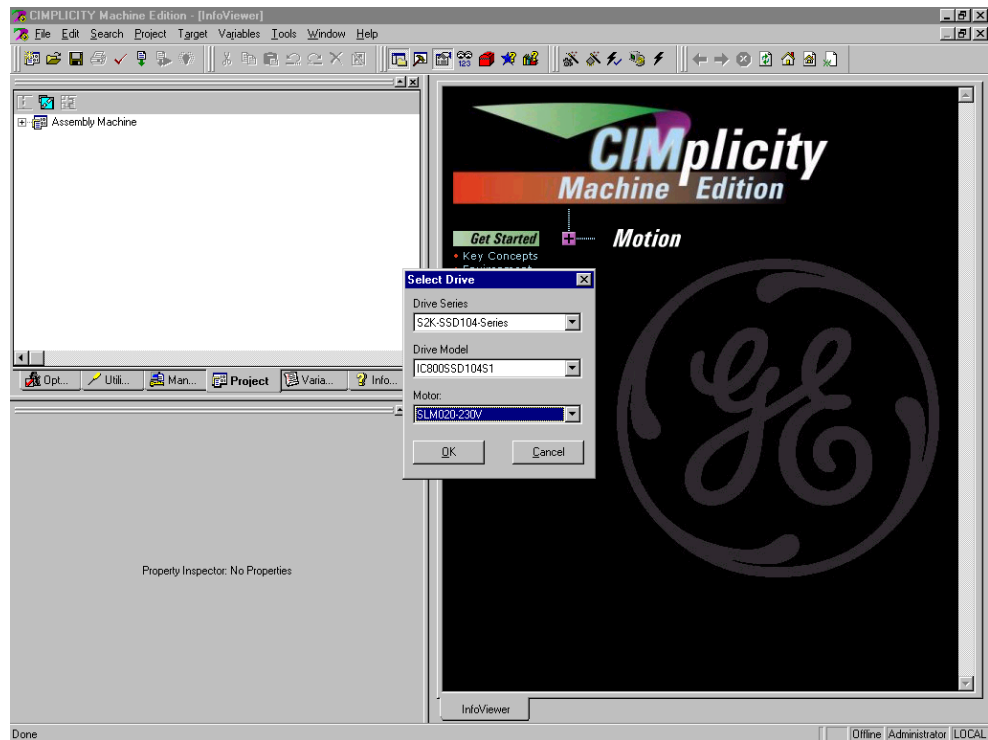

Next you must select your Drive Series, Drive Model and Motor from the pop-up dialog.

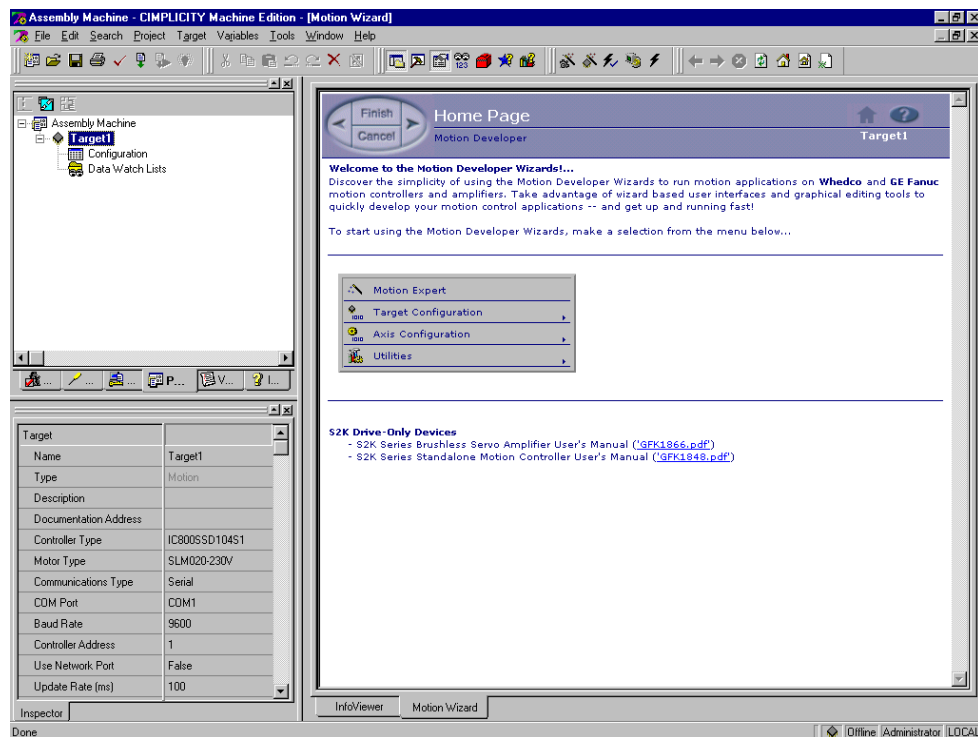

At this point the *Motion Toolbar* should be active and we can activate the terminal window or run the Motion Expert wizard.

## Turning the Motion Toolbar ON or OFF

The Motion toolbar provides access to the terminal window and should appear by default. If you do not see the Motion Toolbar, it can be turned on using the *Tools* option on the *Menu* bar:

**To turn the Motion toolbar on**, (1) click Tools on the Menu bar, (2) click Toolbars on the Tools menu, then (3) click Motion on the submenu.

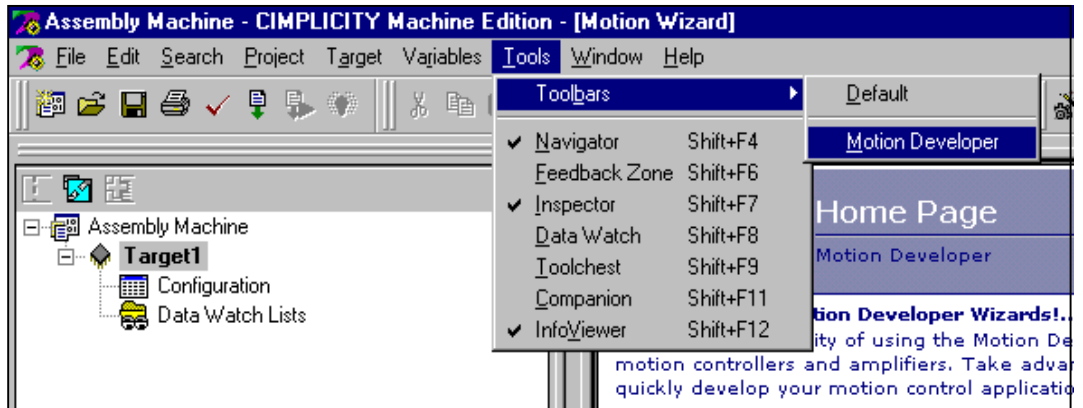

Once activated the Motion Toolbar appears as shown below:



↑ Terminal Window Button

Clicking the **Terminal Window Button** will cause the Terminal Window page to be displayed and the terminal communications settings will appear in the Inspector window as shown below.

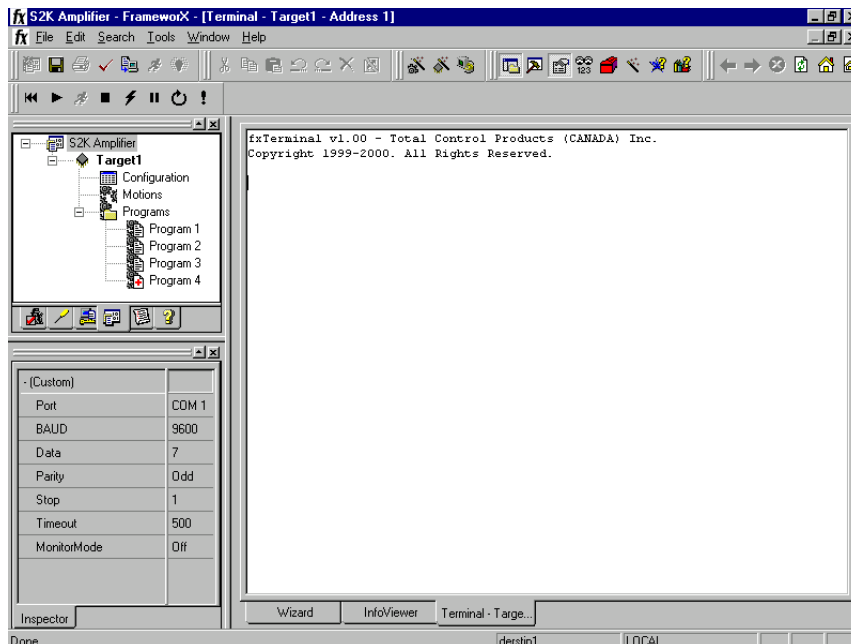

The default communication settings should be correct for the S2K amplifier and not require any changes. Make sure that the *Port* assignment agrees with the physical COM port to which you connected your serial cable. If you need to change the *Port* setting you must do the following:

- In the *Navigator*, right-click the Target1 entry and choose *Properties* from the shortcut menu.
- The Inspector window should now display the settings shown in the example below and you can select a new *Com Port* by clicking on the entry to display the drop-down list box.

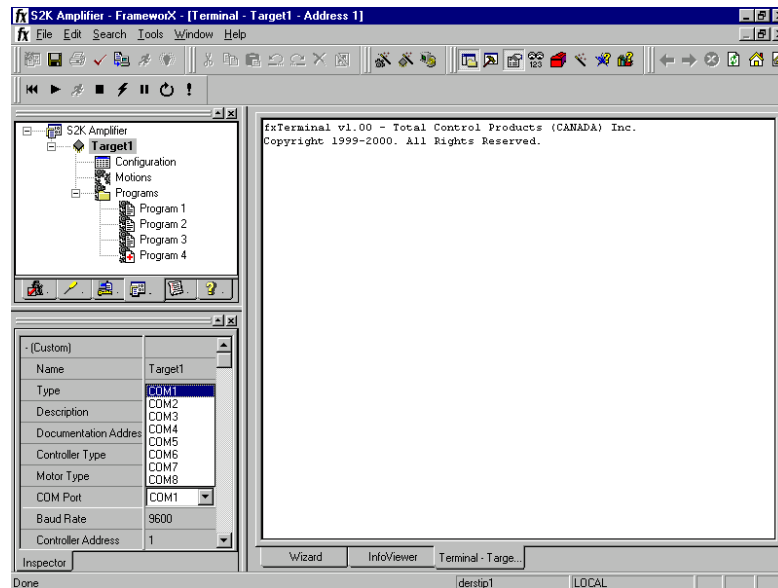

At this point, assuming your serial cable connections and port assignment are correct, you are ready to communicate with the amplifier.

Place the mouse cursor anywhere in the terminal window and click once to place the Windows focus on the terminal, and then press the Enter key on your keyboard several times. The “\*GE Fanuc S2K Series” prompt should eventually be displayed as shown below.

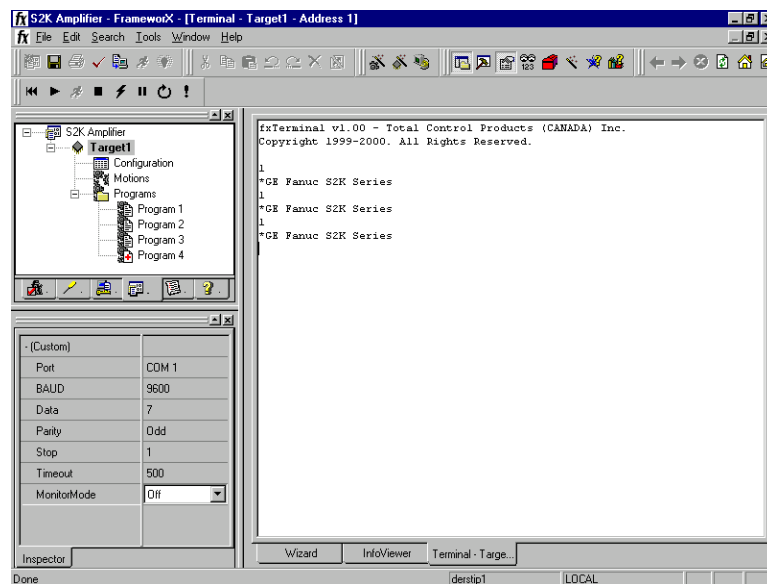

Next, try to query the contents of the Fault Code register (FC) using the query command (Q or ?). In the terminal window, type FC? and then the <Enter> key. The *Lost Enable* and *Power Failure* messages should be displayed as shown below. This is normal since the Enable digital input is not yet connected and the power failure fault is present each time the amplifier is energized.

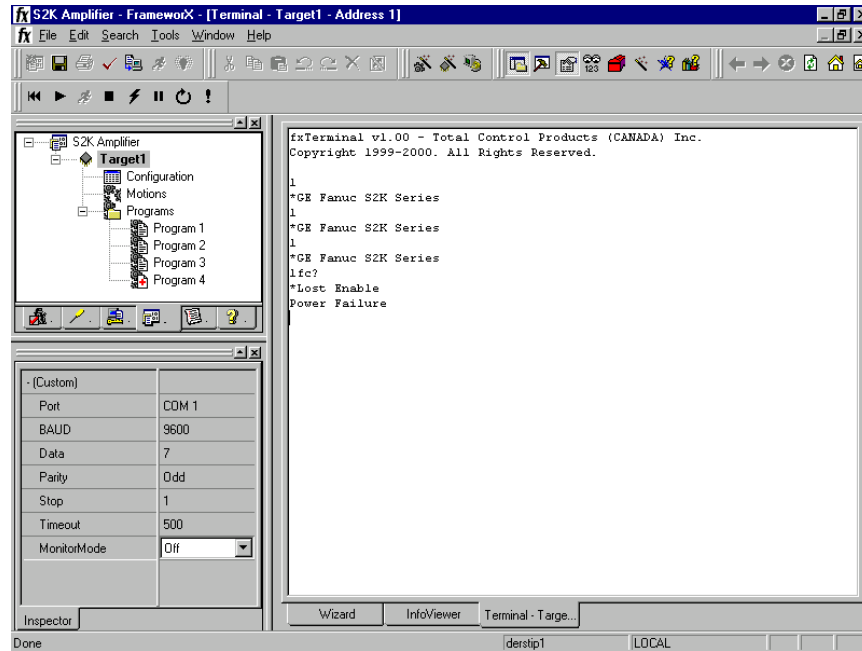

Congratulations, you have successfully established communications with the amplifier and are ready to move on to *Configuring the Operating Mode*.

## 4.2 Configuring The Operating Mode

The S2K series amplifiers can be configured for operation in any of the following modes:

- |                               |   |
|-------------------------------|---|
| Torque (current) control mode | In <i>torque mode</i> , the analog command input (AI1) tells the amplifier how much torque to generate as a function of the command input voltage. This mode requires an external controller to handle position control with the S2K amplifier. |
| Velocity control mode         | In velocity mode, the analog command input (AI1) tells the amplifier how much velocity to generate as a function of the command input voltage. This mode requires an external controller to handle position control with the S2K amplifier.     |
| Position (follower) mode      | Position mode makes use of the auxiliary encoder input (IN_A and IN_B) when using a pulse input from an external source such as a pulse generator card, a quadrature encoder, or a handwheel.   |

You must first decide which mode is appropriate for your application and then wire the Auxiliary I/O connections and configure the amplifier for that mode. The Motion Developer includes a Motion Expert wizard that will guide you through the various steps required to configure an S2K amplifier for each of the control modes. The following sections describe the configuration process for each operating mode.

### 4.2.1 Torque Mode Operation

Torque mode is the default mode in firmware for a new amplifier, and so the mode should not have to be changed. The Motion Developer Motion Expert wizard uses velocity mode as the default configuration. To verify the mode setting, do a query on the MT parameter by typing MT? <Enter> in the terminal window. The response should be “TORQ” as shown in the following screen.

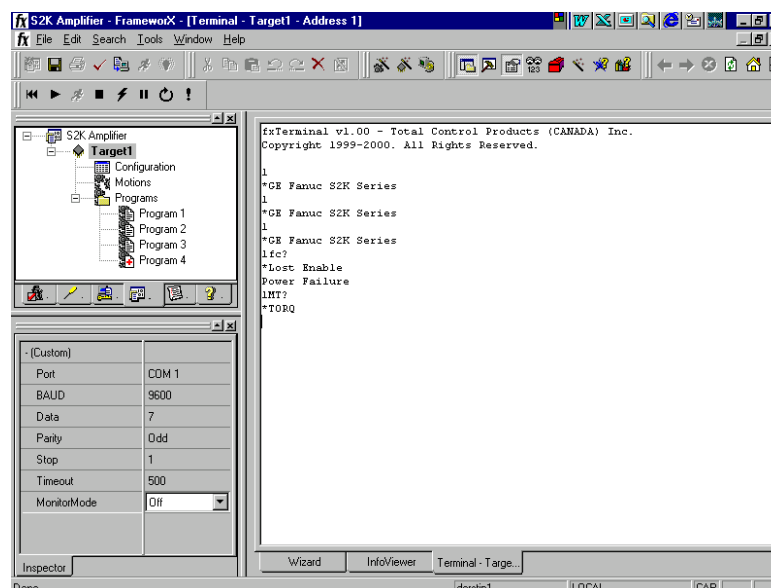

You can change the mode by typing “MT=” followed by the desired mode keyword.

In torque mode the differential command input is intended to be used as a  $\pm 10\text{Vdc}$  torque command interface to a host motion. The Analog Input Deadband (AIB1) and Analog Input Offset (AIO1) parameters are used to configure the deadband and voltage offset for this input if necessary for your application. See Chapter 5 for detailed descriptions of these parameters.

Usually, it is necessary to scale the analog torque command input based on the application requirements. In the S2K amplifier the gearing ratio parameters (GRN and GRD) can be used to scale the command to represent a specific motor torque at a given voltage input. The base scaling of the torque command input for the default ratio of 1 (GRN/GRD = 1) is as follows:

$$1 \text{ Volt Command} = 10\% \text{ Amplifier Peak Current}$$

The process for rescaling the torque command input is shown in the example below. Keep in mind that servo amplifiers control motor torque by regulating the current delivered to the motor. When we refer to torque scaling or limiting we are really scaling or limiting the current output from the amplifier. The constant of proportionality that relates these two factors is the *Torque Constant* of the motor. The motor specifications in Chapter 2 show the **nominal** value for each motor. The actual value can vary from this nominal value by as much as  $\pm 10\%$  from one motor to the next. It is important to understand these limits when trying to precisely control motor torque. Applications that require greater precision must use an in-line torque transducer and separate torque regulator.

There is an OK digital output available on the S2K amplifier that can be wired back to the host controller to indicate amplifier status. See Chapter 3 for more details on the Auxiliary I/O connections.

### 4.2.1.1 Example of Scaling The Torque Command Input

For our application we want to scale the torque command input so that 5 volts equals 84 in-lb peak torque on an SLM100 motor. The base scaling for the torque command input is 10% Amplifier Peak Current/Volt assuming a gearing ratio of 1. Therefore, we can calculate the required scaling ratio as follows:

The peak torque rating of motors shown in the specifications in Chapter 2 generally equates to the full peak current rating of the amplifier recommended for use with that motor (see Section 1.5 for valid motor/amplifier combinations). Therefore, the SLM100 motor peak rating of 84 in-lb would normally be produced at 100% of the SSD107 amplifier’s peak current rating. This means that percent peak current is the same as percent peak torque and we can use the two factors interchangeably. From the base scale factor we know that 100% peak current = 10 Volts and this is the same as 100% peak torque = 10 Volts. But we need to generate 100% current (torque) at 5 Volts. The following equation can be used to determine the correct scaling ratio:

$$\begin{aligned} \frac{GRN}{GRD} &= \frac{DesiredScaling(\%PeakTorque/Volt)}{BaseScaling(\%PeakTorque/Volt)} \\ &= \frac{100\%/5Volts}{10\%/Volt} = 2 \end{aligned}$$

Therefore, we need to set GRN=2 and GRD=1.

In order to enable the new command, scaling the *Gearing Enable* parameter must be set (GRE=1) in the terminal window.

## 4.2.2 Velocity Mode Operation

Since torque mode is the default for a new amplifier, the Motion Type parameter must be changed to enable velocity mode. The Motion Developer Motion Expert wizard can be used to change the mode or you can change the mode manually by typing “MT=VEL” in the terminal window. You can verify the mode setting by doing a query on the MT parameter by typing MT? <Enter> in the terminal window. The response should be “VEL” as shown below.

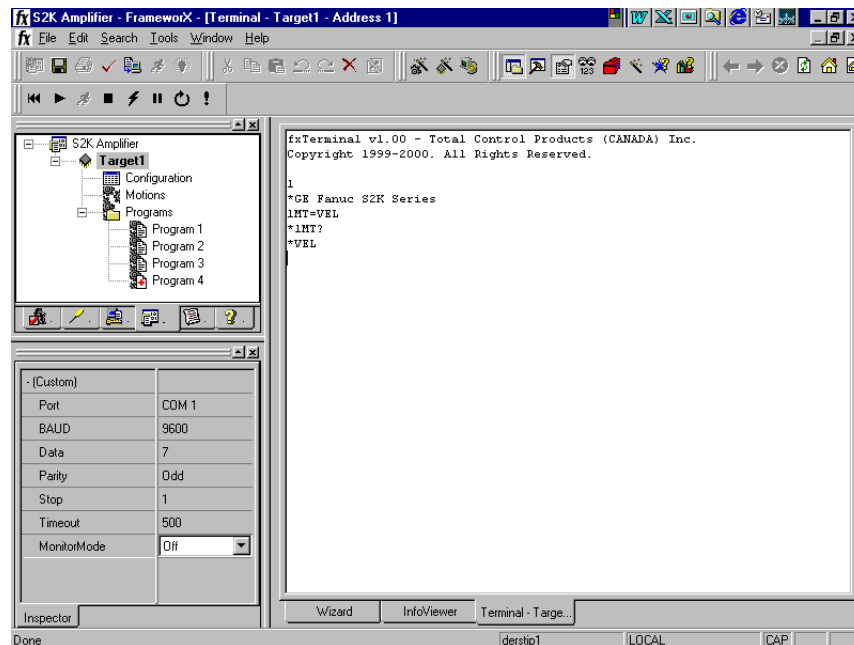

The differential command input is intended to be used as a  $\pm 10\text{Vdc}$  velocity command interface to a host motion controller. The Analog Input Deadband (AIB1) and Analog Input Offset (AIO1) parameters are used to configure the deadband and voltage offset for this input if necessary for your application. See Chapter 5 for detailed descriptions of these parameters.

Usually, it is necessary to scale the analog torque command input based on the application requirements. In the S2K amplifier the gearing ratio parameters (GRN and GRD) can be used to scale the command to represent a specific motor velocity at a given voltage input. The base scaling of the velocity command input for the default ratio of 1 (GRN/GRD = 1) is as follows:

$$1 \text{ Volt Command} = 1228.8 \text{ Motor RPM}$$

The Motion Developer Motion Expert wizard can be used to configure this scaling or you can set the parameters manually. The process for rescaling the velocity command input is shown in the example below.

There is an OK digital output available on the S2K amplifier that can be wired back to the host controller to indicate amplifier status. See Chapter 3 for more details on the Auxiliary I/O connections.

### 4.2.2.1 Example of Scaling The Velocity Command Input

For our application we want to scale the velocity command input so that 10 volts equals 3000 rpm on the motor. The base scaling for the velocity command input is 1228.8 RPM/Volt assuming the default gearing ratio of 1. Therefore, we can calculate the required ratio as follows:

$$\begin{aligned} \frac{GRN}{GRD} &= \frac{DesiredScaling(RPM / Volt)}{BaseScaling(RPM / Volt)} \\ &= \frac{300}{1228.8} = 0.2441406 \\ &= \frac{1000}{4096} \end{aligned}$$

Therefore, we need to set GRN=1000 and GRD=4096.

In order to enable the new velocity command scaling, the *Gearing Enable* parameter must be set (GRE=1) in the terminal window.

### 4.2.3 Position Mode Operation

The S2K amplifiers can operate in a position (pulse follower) mode, which allows them to be connected to stepper controllers such as the GE Fanuc OCS or to be used for simple fixed ratio following of a master encoder or other pulse source.

You can change to the position control mode using the Motion Developer Motion Expert wizards or by typing “MT=POS” in the terminal window. You can verify the mode setting by doing a query on the MT parameter by typing MT? <Enter> in the terminal window. The response should be “POS” as shown below.

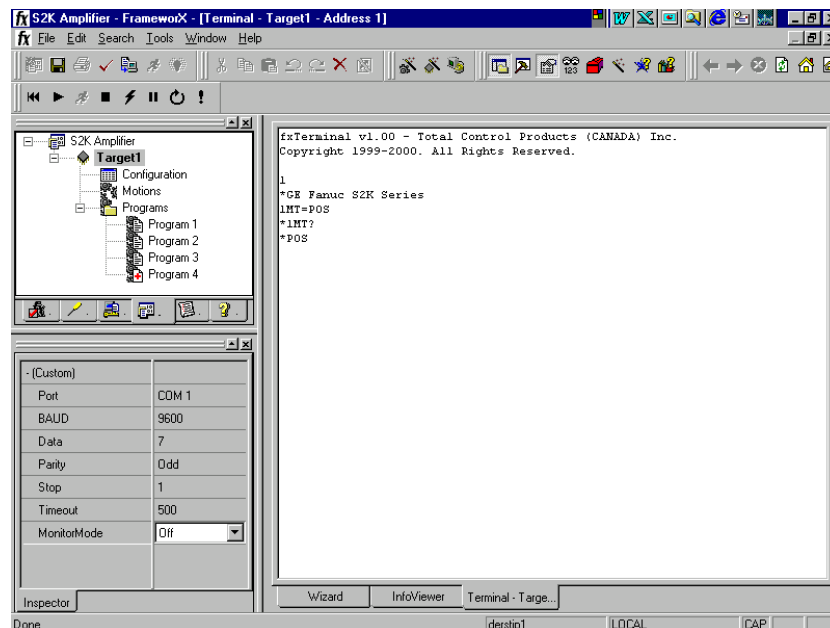

Next, you must configure the type of pulse input that will be used to control the amplifier. The Auxiliary Encoder Type (QTX) parameter is used to select the required pulse command signal type from the following options:

<b><i>Q4</i></b> ( <i>quadrature x4</i> )	Sets the input for two pulse waveforms in quadrature with a pulse multiplier of 4. Use this option for a master encoder interface.(Default)
<b><i>PD</i></b> ( <i>pulse/direction</i> )	Sets the input for a pulse input on channel A and a direction input on channel B.
<b><i>CW</i></b> ( <i>CW/CCW</i> )	Sets the input for a pulse input on channel A for CW motion and a pulse input on channel B for CCW motion.

To change the input type enter “QTX=” followed by one of the 2-letter options above and then press <Enter>.

Next, you must configure the pulse-scaling ratio that determines how far the motor will move for each input pulse. This ratio is set using the Gearing Numerator (GRN) and Gearing Denominator (GRD) registers. Together they form the scaling ratio as GRN/GRD and relate the input pulses to motor pulses as shown in the following formula:

$$\text{Motor Pulses} = \text{Gearing Input Pulses} * \text{GRN/GRD}$$

See the example below for more detail on how to determine the proper ratio.

The Gearing Enable register must then be set (GRE=1) to enable the gearing mode and the Gearing Bound (GRB) register sets a limit, if required, on the maximum velocity (pulses/second) that the electronic gearing mode can command. There is also a smoothing algorithm included in the S2K amplifier for electronic gearing applications that are too sensitive. The Gearing Filter Constant (GRF) parameter configures the level of filtering based on the application requirements. Finally, the Gearing Input Source Selection (GRI) parameter provides a way to run the motor at a fixed speed (jog) using an internal pulse generator, which runs at a fixed 2048 pulses/second. This function may be useful during machine start-up. See Chapter 5 for more detail on using these parameters.

Make sure your pulse source is properly connected to the Auxiliary I/O connector or Pulse Input connector (SSD216 and SSD228) on the amplifier as shown in Chapter 3 – *Auxiliary I/O Wiring*.

### 4.2.3.1 Examples of Scaling The Pulse Command Input

In this example we want to scale the amplifier so that a 1000 line auxiliary encoder will produce one motor revolution for each encoder revolution.

The GE Fanuc S-Series motors include 2500 line encoders which generate 10,000 quadrature pulses/motor revolution. The MTR-Series resolver-based motors generate 4096 pulses per motor revolution. So, for an application using a 1000 line auxiliary encoder (4000 quadrature pulses), we can determine the required ratio as follows:

#### **S-Series Motors:**

$$10,000 \text{ motor pulses/rev} * (\text{motor rev/encoder rev}) = (4000 \text{ gearing pulses/rev}) * \text{GRN/GRD}$$

Solving for the gearing ratio we have:

$$\text{GRN/GRD} = 10,000/4000$$

Therefore, by setting GRN = 10,000 and GRD = 4000 the motor will make one revolution for each revolution of the master encoder.

**MTR-Series Motors:**

$$4096 \text{ motor pulses/rev} * (\text{motor rev/encoder rev}) = (4000 \text{ gearing pulses/rev}) * \text{GRN/GRD}$$

Solving for the gearing ratio we have:

$$\text{GRN/GRD} = 4096/4000$$

Therefore, by setting GRN = 4096 and GRD = 4000 the motor will make one revolution for each revolution of the master encoder.

If instead, we wanted the motor to make  $\frac{1}{4}$  revolution for each encoder revolution, the following ratio would be required:

**S-Series Motors:**

$$10,000 \text{ motor pulses/rev} * (0.25 \text{ motor rev/encoder rev}) = (4000 \text{ gearing pulses/rev}) * \text{GRN/GRD}$$

Again, solving for the gearing ratio we have:

$$\text{GRN/GRD} = (10,000)(0.25)/4000 = 2500/4000$$

Therefore, by setting GRN = 2500 and GRD = 4000, the motor will make  $\frac{1}{4}$  revolution for each revolution of the master encoder.

**MTR-Series Motors:**

$$4096 \text{ motor pulses/rev} * (0.25 \text{ motor rev/encoder rev}) = (4000 \text{ gearing pulses/rev}) * \text{GRN/GRD}$$

Again, solving for the gearing ratio we have:

$$\text{GRN/GRD} = (4096)(0.25)/4000 = 1024/4000$$

Therefore, by setting GRN = 1024 and GRD = 4000, the motor will make  $\frac{1}{4}$  revolution for each revolution of the master encoder.

### 4.2.3.2 Configuring The Encoder Output

The S2K amplifier is equipped with a quadrature encoder output. The electrical specifications for this output are shown in Chapter 2.

The encoder output buffers either the motor feedback (resolver or encoder depending on the S2K model) or auxiliary encoder signals and makes them available as quadrature (A-Channel, B-Channel and Index) signals to another S2K controller or amplifier for electronic gearing or cam following or to a host controller for position feedback.

The S-Series motor encoder resolution is 2500 lines per revolution, so the encoder output supports a maximum resolution of 10,000 quadrature counts/revolution of the motor. MTR-Series motors use resolver feedback and when matched with a resolver-based S2K amplifier the maximum feedback resolution is 4096 counts/revolution of the motor.

The encoder output is a differential output source (see Section 2.1 for specifications) with user selectable source via the Encoder Output Type (EOT) parameter. The EOT parameter determines whether this output tracks the auxiliary encoder input or the motor feedback:

- **When EOT=0** (default) the encoder output buffers the **auxiliary encoder input** pulse-for-pulse. If the auxiliary input is a quadrature encoder the output will be quadrature. If the auxiliary input is CW/CCW pulses, the output will be in this same format.
- **When EOT is non-zero** the output tracks the **motor feedback** (up to the full resolution of 2500 or 1024 lines/rev based on feedback type), and the setting of the EOT register determines the output resolution. The allowed values for this resolution are 500, 625, 1000, 1250, 2000, and 2500 lines/revolution for encoder-based models and 250, 256, 500, 512, 1000, and 1024 lines/revolution for resolver-based models. The quadrature resolution would be four times greater than the EOT setting.

The marker pulse width is fixed at  $1/5000^{\text{th}}$  of the source encoder revolution (auxiliary encoder or motor feedback based on setting of EOT). This implies that the marker pulse output width will vary with encoder speed and the smallest width will occur at the highest speed. For example, if the source device is rotating at 1000 RPM or 16.667 rev/sec then the encoder takes 0.06 seconds per revolution. Therefore,  $1/5000^{\text{th}}$  of this value, or 12  $\mu\text{S}$ , represents the marker pulse width at that speed. The encoder output is connected on the Auxiliary I/O connector. Addition details can be found in Chapter 3 – *Auxiliary I/O Wiring-Encoder Output*.

## 4.3 Setting The Torque Limit

The S2K amplifiers include the ability to limit the continuous torque that the motor can deliver if required by the application. There are two methods of torque limiting that are selected using the Torque Limit Enable (TLE) command:

TLE = 1: Fixed limit based on the Torque Limit Command (TLC)

TLE = 2: Dynamic limit based on the voltage level on Analog Input 2 (AI2)

To select the desired method, type TLE = 1 or TLE = 2 in the terminal window followed by the <Enter> key. By default, the torque limit is disabled (TLE=0). Remember to set the value for the Torque Limit Command (TLC) if you select TLE=1. See Chapter 5 for more detail on using these parameters.

## 4.4 Setting Motor Direction

There are two parameter that can affect the direction the motor will rotate based on a particular polarity of the command input. The Direction (DIR) parameter is normally used for this purpose and defaults to Clockwise (CW). This means that for a positive command the motor will rotate in the clockwise direction viewing into the motor shaft. See the Direction (DIR) parameter in chapter 5 for a definition for a positive command based on the selected operating mode. To change the motor direction type DIR=CCW in the terminal window.

The Gearing Denominator (GRD) parameter can also be used to reverse the directional sense of the motor when the command scaling ratio is enabled (GRE=1). When GRD is set to a negative value the motor will rotate counterclockwise for a positive command input.

### Note

**When both DIR = CCW and GRD is negative the two factors cancel and the motor will rotate in the clockwise direction for a positive command input.**

The Fault Code register (FC) can be queried in the terminal window to examine the current state of the Direction parameter.

## 4.5 Enable Input

The S2K amplifier has an Enable discrete input that must be connected before the amplifier will run the motor. **The Enable input is also used to reset amplifier fault conditions.** Each time power is applied to the amplifier the Power Failure (PF) fault is activated and must be cleared by activating the Enable input **AFTER** power-up. Therefore the Enable input cannot be hardwired using a wire jumper. It must be connected to a logic output on the host controller.

Use the guidelines provided in Chapter 3, “Auxiliary I/O Wiring,” to wire your amplifier in either a sinking or sourcing configuration.

The Fault Code register (FC) can be queried in the terminal window to examine the current state of the enable input and the front panel LED display will show the LE fault code when the Enable input is inactive.

## 4.6 Configuration Parameters

The S2K amplifiers use various configuration and servo tuning parameters to optimize system performance. Some of these parameters are determined based on the specific motor you are using.

The first step in the configuration process is to identify your motor and amplifier combination from the part numbers shown in Table 1-1 and then configure the CURC, CURP and KL parameters using the Motion Developer Motion Expert wizard or terminal window.

For example, assume we are configuring an SDM100 with an SSD107 amplifier using Motion Developer. Type the following in the terminal window:

```
CURC=77 <Enter>
```

```
CURP=100 <Enter>
```

```
KL=10 <Enter>
```

The screen should appear similar to the example below:

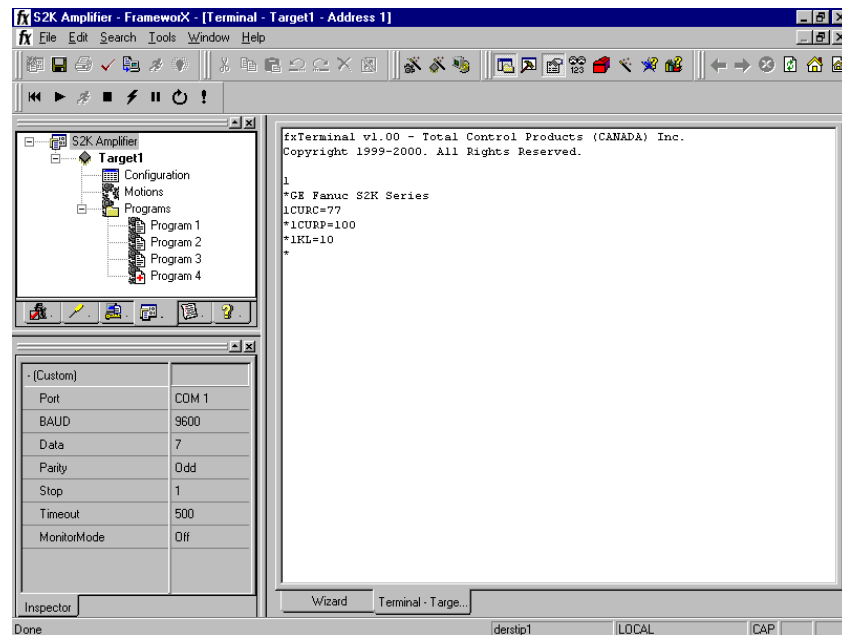

If your application requirements dictate limiting the peak torque of the motor to a value less than its full rating, you must set the CURP parameter to a lower value. Since the CURP values shown in Chapter 5 correspond to the full peak torque for each motor, you can use this value as a baseline from which to scale the required CURP value. For example, if you wanted to limit the SLM040 motor which has a peak torque rating of 33.6 in-lb (from S-Series Motor Specifications Table in Chapter 2) to a peak torque of 25 in-lb you can calculate the CURP value as follows:

1. Determine ratio of required peak torque to rated peak torque

$$\begin{aligned}
 \text{Ratio} &= (\text{required peak torque}/\text{rated peak torque}) \\
 &= (25 \text{ in-lb}/33.6 \text{ in-lb}) \\
 &= 0.744
 \end{aligned}$$

2. Determine the new CURP value

$$\text{CURP} = \text{Ratio} * (\text{Standard CURP from Chapter 5})$$

$$= 0.744 * (90\%)$$

$$= 66.9 \%$$

3. Enter the new CURP value in the terminal window by typing `CURP=66.9 <Enter>`.

You are now ready to tune the servo.

## 4.7 Tuning

If you have completed all of the previous sections and have verified your wiring connections you are now ready to run the motor and set the tuning parameters.

### Caution

**For the initial test we recommend that you disconnect the motor from any load in order to ensure that the system is under control before trying to move the machine.**

### 4.7.1 Using Autotuning

The S2K amplifiers support an autotuning function that attempts to determine the proper gain settings (KP, KD, KI and KT) by moving the motor a short distance. On robust machines with low backlash or lost motion and system resonances that are higher in the frequency range, the autotuning will typically work well. The motor peak torque to system inertia ratio ( $T_p/J$ ) must be greater than  $125 \text{ rad/sec}^2$  but less than  $125,000 \text{ rad/sec}^2$  for AUTOTUNE to work properly. See Chapter 5 for more detail on the AUTOTUNE command.

It may be necessary to optimize the settings manually if system performance dictates.

We will now use the autotuning function to set the first pass at the unloaded system gains. Servo tuning is dependent on the connected load and friction. It is recommended that you tune the system initially with no load connected to verify proper operation of the servo. Then, once the machine is operational and the normal running load is connected, it is necessary to repeat the tuning process.

### Warning

**When the AUTOTUNE function runs, it will automatically turn the motor shaft a few turns in each direction. You must insure that the motor shaft can be turned safely before starting the AUTOTUNE function. Also, you should have a way to stop the motor quickly, should it be required. All personnel working in the area should be alerted that the motor will be run, and any machinery or mechanism connected to the motor should be secured and in safe running condition. All safety equipment and guarding should be installed and functional. Failure to heed this warning could result in injury to personnel and damage to equipment.**

The Autotune function can be run from the Autotune wizard in Motion Developer or manually from the terminal window.

To initiate the Autotune function from the terminal window follow the procedure below:

1. Set the Enable input to false
2. Type AUTOTUNE <Enter> in the terminal window
3. Within 10 seconds activate the Enable input
4. When complete, autotune will disable the drive and display the Lost Enable (LE) fault code on the LED display. An asterisk will be displayed in the terminal window.
5. If AUTOTUNE fails an error message preceded by a question mark will be displayed in the terminal window.

## 4.7.2 Manually Setting the Tuning Parameters

The S2K amplifier uses several gain parameters to optimize the servo response for each application. Most of the gain settings are dependent on the torque/inertia ratio of the servo/machine system. The following gain settings can be manually adjusted using the terminal window.

*Proportional Gain (KP)*: constant gain applied to the following error

*Derivative Gain (KD)*: gain constant multiplied by the time derivative of the following error

*Integral Gain (KI)*: gain constant multiplied by the time integral of the following error

*Filter Time Constant (KT)*: eliminates dither

Chapter 5 provides more detail on each parameter, including a formula to calculate an appropriate starting value based on system data. You should use these values as a starting point or use the AUTOTUNE command to determine initial gain values.

To change a gain in the terminal window, simply type the parameter, for example  $KP=100$  followed by the Enter key. If desired, you can use the query command (? or Q) to determine the current or new value for each gain setting. The following procedure can be used to manually tune the servo:

1. Activate the Enable input to clear any faults and ready the drive for operation.
2. Apply a command from the host controller to run the motor at a slow speed using low acceleration and deceleration rates. While running, check for smooth, stable response.
3. Gradually increase the velocity and acceleration/deceleration rate while running the motor and check for smooth, stable response.
4. Continue to repeat the previous step, increasing velocity and acceleration/deceleration rate each time until you reach the desired final operating values. To decrease instability and to tune for optimum response, use the following guidelines to adjust the tuning parameters:
  - Increase KD until the motor makes an audible “whine,” and then reduce KD to 75 – 85% of this value.
  - Increase KI until the motor becomes unstable, and then reduce KI to 75 – 85% of this value.

# Chapter 5

## Software Reference

### 5.1 Software Overview

This chapter contains a comprehensive listing of all registers and commands for the S2K Series amplifiers. Commands are arranged in alphabetical order with symbolic commands listed first. The diagram below shows an example of the typical page layout for each command or register. There is also an alphabetical quick reference summary guide to make locating a particular command even easier.

<b>Analog Input</b>		Command Mnemonic
<b>Class:</b>	Input/Output Register	
<b>Syntax:</b>	<i>AIp1</i>	
<b>Parameters</b> <i>p1</i>	<i>allowed values</i> 1 or 2 (analog input number)	
<b>Range:</b> <i>units</i> <i>minimum</i> <i>maximum</i>	volts -10.000 10.000	Range of values for registers (not applicable to commands)
<b>Restrictions:</b>	Read only.	
<b>Use:</b>	Defines the value in volts of one of the two general-purpose hardware analog inputs.	
<b>Related Registers:</b>	AO	

Limits on use

Description and how to use the register or command

The Motion Developer terminal window or other VT100-compliant terminal emulator can be used to set or query the values of the amplifier registers as well as execute commands such as AUTOTUNE. To set a register value, simply type the register name followed by the equal sign and the desired value. Hitting the *Enter* key will load the new value into amplifier memory (examples: TLE=1, DIR=CW). To query the current value of a register, type the command followed by a question mark (examples: FC?, TLC?, GRN?) or the letter Q (FCQ, TLCQ, GRNQ) followed by pressing the *Enter* key.

## 5.2 Alphabetical Command and Register Guide

Reg/Cmd	Class	Description	Page
?	Diagnostic	reports value of register	3
AI	Input/Output	analog input	3
AIB	Input/Output	analog input deadband	4
AIO	Input/Output	analog input offset	4
AO	Input/Output	analog output	5
AUTOTUNE	System	automatically sets up tuning parameters	6
CLM	System	clears user memory; resets registers to defaults	7
CMD	Axis	command output	7
CMO	Axis	commutation angle offset	8
CMR	Axis	motor poles to resolver poles commutation ratio	9
CURC	Axis	continuous current limit	10
CURP	Axis	peak current limit	11
DIR	Axis	direction of motor	12
EOT	Axis	encoder output type	13
FC	System	fault code register	14
FE	Axis	following error	15
FEB	Axis	following error bound	15
FI	System	fault input	16
FR	Axis	feedback resolution	17
GRB	Motion	gearing bound	17
GRD	Motion	gearing denominator	18
GRE	Motion	gearing enable	20
GRF	Motion	gearing filter constant	20
GRI	Motion	Gearing input source selection	21
GRN	Motion	gearing numerator	22
IO	Input/Output	general I/O	24
KD	Axis	derivative control gain	25
KI	Axis	integral control gain	26
KL	Axis	motor inductance	27
KP	Axis	proportional control gain	28
KT	Axis	filter time constant	29
MOTORSET	System	automatically sets up motor constants	30
MT	Motion	motion type	31
Q	Diagnostic	reports value of register	31
QTX	Axis	auxiliary encoder type	32
REVISION	Diagnostic	reports firmware revision	32
SRA	System	axis status	33
STEP	Motion	step input	34
TLC	Axis	torque limit command	35
TLE	Axis	torque limit enable	36

## 5.3 Commands and Registers

### ?

#### Reports Value of Register

---

<b>Class:</b>	Diagnostic Command	
<b>Syntax:</b>	<i>pl?</i> (e.g., CURC? FC?)	
<b>Parameters:</b>	<i>allowed values</i>	<i>description</i>
<i>pl</i>	any register	register
<b>Use:</b>	This command is used in the terminal window to report the value of any register. It is identical to the Q command.	
<b>Related Commands:</b>	Q	

### AI

#### Analog Input

---

<b>Class:</b>	Input/Output Register	
<b>Syntax:</b>	<i>AIpl</i>	
<b>Parameters</b>	<i>allowed values</i>	
<i>pl</i>	1 or 2 (analog input number)	
<b>Range:</b>	<i>units</i>	volts
	<i>minimum</i>	-10.00
	<i>maximum</i>	10.00
<b>Restrictions:</b>	Read only.	
<b>Use:</b>	Reports the instantaneous value in volts of the two hardware analog inputs located on the Auxiliary I/O connector.	
<b>Examples:</b>	<i>AI1?</i>	(* report value of analog input one from the terminal window)
	<i>AI2?</i>	(* report value of analog input two from the terminal window)
<b>Related Registers:</b>	AO	

## AIB Analog Input Deadband

---

<b>Class:</b>	Input/Output Register
<b>Syntax:</b>	<i>AIBp1</i> (e.g., AIB1 AIB2)
<b>Parameters</b>	<i>allowed values</i>
<i>p1</i>	1 or 2 (analog input number)
<b>Range:</b>	
<i>units</i>	volts
<i>default</i>	0
<i>minimum</i>	0
<i>maximum</i>	10.00
<b>Use:</b>	Defines a range over which the analog input remains constant at zero volts. Deadband reduces hunting around the zero command level. When the analog input AI1 is less than or equal to AIB1, the analog input is set to 0. When the analog input AI2 is less than or equal to AIB2, the analog input is set to 0. The deadband resolution is in 10 mV increments.
<b>Examples:</b>	
AIB2=1.5	(* set analog input deadband for AI2 equal to 1.5 V)
AIB2?	(* report value of analog input deadband from the terminal window)
<b>Related Registers:</b>	AI, AIO

## AIO Analog Input Offset

---

<b>Class:</b>	Input/Output Register
<b>Syntax:</b>	<i>AIOp1</i> (e.g., AIO1 AIO2)
<b>Parameters</b>	<i>allowed values</i> <i>description</i>
<i>p1</i>	1 or 2                                      analog input number
<b>Range:</b>	
<i>units</i>	volts
<i>default</i>	0
<i>minimum</i>	-10.00
<i>maximum</i>	10.00
<b>Use:</b>	The analog input offset one, AIO1, is used to add a voltage offset to analog input one, AI1. Analog input offset two, AIO2, is used to add a voltage offset to analog input two, AI2. Often the analog command output from a host controller will generate a small voltage even at zero command. The offset should be adjusted to counteract this voltage to eliminate drift. If the host controller is closing a position loop, the controller should be run open loop, if possible, while making the offset adjustment. The offset resolution is in 10mV increments.
<b>Examples:</b>	
AIO1=2.5	(* set analog input offset for AI1 equal to 2.5 V)
AIO1?	(* report offset value of analog input 1 from Terminal window)
<b>Related Registers:</b>	AI

# AO

## Analog Output

<b>Class:</b>	Input/Output Register
<b>Syntax:</b>	AO
<b>Range:</b>	
<i>units</i>	volts
<i>default</i>	0
<i>allowed values</i>	-10.000 through 10.000 VLA (actual velocity of axis motor) CMD (instantaneous value of amplifier output current) FE (following error)
<b>Restrictions:</b>	FE valid only when amplifier is in position mode (MT=POS).
<b>Use:</b>	Defines the value in volts of the hardware analog output.
<b>Remarks:</b>	Setting the analog output to VLA, CMD, or FE enables the analog output to assume a value based on the following scaling:  VLA (10 Volts = 20 Krpm on the motor) CMD (10 Volts = maximum peak current rating of controller) FE (10 Volts = 128 pulses of following error)
<b>Examples:</b>	
AO=1.5	(* set analog output equal to 1.5 V)
AO=CMD	(* set analog output equal to current output)
AO?	(* report value of analog output from the terminal window)
<b>Related Registers:</b>	AI

## AUTOTUNE Automatically Sets Up Servo Tuning Constants

<b>Class:</b>	System Command
<b>Syntax:</b>	AUTOTUNE
<b>Restrictions:</b>	Valid only when amplifier is in position mode (MT=POS) or velocity mode (MT=VEL).
<b>Use:</b>	This command automatically sets up the control tuning constants, which are KD, KI, KP, and KT.
<b>Remarks:</b>	<p>This command can only be initiated when the amplifier is not enabled. Servo tuning is dependent on the connected load and friction. It is often necessary to tune the system initially with no load connected to verify proper operation of the servo. Then, once the machine is operational and the normal running load is connected, it is necessary to repeat the tuning process.</p> <p>For final tuning on the machine, the motor should be connected to the load when using this command. When executed, it causes the axis to move half a revolution in the forward direction. Be sure that the axis is free to move this far before executing this command.</p> <p>Use the following procedure:</p> <ol style="list-style-type: none"> <li>1. Ensure motor is connected to the load and free to move at least one revolution in each direction</li> <li>2. Set the Enable input to false</li> <li>3. Set Motion Type (MT) to POS or VEL</li> <li>4. Type AUTOTUNE &lt;Enter&gt; in the terminal window.</li> <li>5. Set Enable input true within 10 seconds</li> <li>6. When complete, AUTOTUNE will fault the drive on Lost Enable (LE).</li> </ol> <p>This command takes about two seconds to execute. When executed from the terminal window and the autotuning is finished, the controller will return either an asterisk (*) indicating successful completion or a question mark (?) followed by the appropriate error message. The possible error messages are as follows:</p> <ol style="list-style-type: none"> <li>1. TORQUE TO INERTIA RATIO TOO LOW — the torque to inertia ratio of the axis is less than 125 radians/sec<sup>2</sup>.</li> <li>2. TORQUE TO INERTIA RATIO TOO HIGH — the torque to inertia ratio of the axis is greater than 125,000 radians/sec<sup>2</sup>.</li> <li>3. TORQUE RESPONSE NON-LINEAR — autotuning won't work.</li> </ol> <p>If Autotune fails the controller gains must be set manually using the terminal.</p>
<b>Related Commands:</b>	MOTORSET
<b>Registers Used:</b>	KD, KI, KP, KT

---

# CLM

## Clears User Memory; Resets Registers to Defaults

---

<b>Class:</b>	System Command
<b>Syntax:</b>	CLM
<b>Use:</b>	This resets all registers to default values.
<b>Remarks:</b>	<ol style="list-style-type: none"><li>1. This command is irreversible; you cannot retrieve any registers that you have previously set after you execute this command.</li><li>2. This command is entered in the terminal window and will execute only when the amplifier is not enabled.</li></ol>

---

# CMD

## Command Output

---

<b>Class:</b>	Axis Register
<b>Syntax:</b>	CMD
<b>Range:</b>	
<i>units</i>	%
<i>minimum</i>	-20,000.0
<i>maximum</i>	20,000.0
<b>Restrictions:</b>	Read only.
<b>Use:</b>	The command output is used to control the current to the axis motor. It is a percentage of the controller continuous current setting, CURC.
<b>Example:</b>	CMD? (* report position command output from the terminal window)
<b>Related Registers:</b>	CURC

## CMO

### Commutation Angle Offset

<b>Class:</b>	Axis Register
<b>Syntax:</b>	CMO
<b>Range:</b>	
<i>units</i>	degrees
<i>default</i>	Encoder Feedback: -90.0 Resolver Feedback: 90.0
<i>minimum</i>	-180.0
<i>maximum</i>	180.0
<b>Use:</b>	<p>The commutation angle offset of the motor is determined by the motor selected for use with the amplifier. For GE Fanuc motors the correct value is:</p> <p>S-Series Motors: -90 MTR-3S Series Motors: -90 MTR-3N Series Motors: 90 MTR-3T Series Motors: 90</p> <p>If necessary, this value can be set automatically by the MOTORSET command. Only experienced users should make adjustments to this setting after consulting GE Fanuc for assistance.</p>
<b>Related Commands:</b>	CMR, MOTORSET

# CMR

## Motor Poles to Resolver Poles Commutation Ratio

<b>Class:</b>	Axis Register
<b>Syntax:</b>	CMR
<b>Range:</b>	
<i>units</i>	degrees
<i>default</i>	Encoder Feedback: 1 Resolver Feedback: 3
<i>minimum</i>	1
<i>maximum</i>	16
<b>Use:</b>	<p>The motor poles to resolver poles ratio is one of the commutation configuration constants required to run the motor. For motors with resolver feedback this ratio must be set to a value equal to the ratio of the number of motor poles to the number of poles for the feedback resolver. For GE Fanuc motors the correct value is:</p> <p>S-Series Motors: 1 MTR-3S Series Motors: 2 MTR-3N Series Motors: 3 MTR-3T Series Motors: 3</p> <p>If necessary, this value can be set automatically by the MOTORSET command. Only experienced users should make adjustments to this setting after consulting GE Fanuc for assistance.</p>
<b>Related Commands:</b>	CMO, MOTORSET

# CURC

## Continuous Current Limit

<b>Class:</b>	Axis Register
<b>Syntax:</b>	CURC
<b>Range:</b>	
<i>Units</i>	%
<i>default</i>	100.0
<i>minimum</i>	1.0
<i>maximum</i>	100.0
<b>Use:</b>	Limits the current that the drive will continuously supply to the motor. It is a percentage of the maximum continuous current rating of the amplifier.
<b>Remarks:</b>	<p>The Terminal window can be used to set CURC manually or the Motion Expert Wizard in Motion Developer will set CURC automatically when you select your GE Fanuc motor and amplifier model from the selection lists. The values for a specific motor can be calculated as follows:</p> $100\% \times (\text{motor cont. current rating} / \text{drive cont. current rating})$ <p>For example, when using an SDM100 motor with a continuous current rating of 5.6 Amp with an SSD107 amplifier rated 7.2 Amp continuous:</p> $\text{CURC} = 100\% \times (5.6 \text{ Amps} / 7.2 \text{ Amps}) = 77\%.$ <p><b>Do not use the CURC parameter as an application torque limit. For applications that require torque limiting to a value less than rated motor torque use the Torque Limit Current (TLC) command. The TLC setting will reduce the maximum continuous current the drive can output relative to the CURC setting. For example, if CURC is set to 55% on the SSD104 the continuous current output is limited to 2.37 amps (0.55 x 4.3 A). Now, if TLC is set to 50% the amplifier will be further limited to 1.18 amps continuous (0.5 x 2.37 A).</b></p>
<b>Related Registers:</b>	CURP, TLC

# CURP

## Peak Current Limit

<b>Class:</b>	Axis Register
<b>Syntax:</b>	CURP
<b>Range:</b>	
<i>units</i>	%
<i>default</i>	100.0
<i>minimum</i>	1.0
<i>maximum</i>	100.0
<b>Use:</b>	The peak current setting limits the peak value of the current that the drive will supply to the motor. It is a percentage of the maximum peak current rating of the drive.
<b>Remarks:</b>	<p>The terminal window can be used to set CURP manually or the Motion Expert Wizard in Motion Developer will set CURP automatically when you select your GE Fanuc motor and amplifier model from the selection lists. The values for a specific motor can be calculated as follows:</p> $100\% \times (\text{motor peak current rating} / \text{drive peak current rating})$ <p>For example, when using an SLM040 motor rated 7.75 amps peak with an SSD104 amplifier rated 8.6 Amp peak,</p> $\text{CURP} = 100\% \times (7.75 \text{ Amps} / 8.6 \text{ Amps}) = 90\%.$
<b>Related Registers:</b>	CURC

# DIR

## Direction of Motor

**Class:** Axis Register

**Syntax:** DIR

**Range:**  
*default* CW  
*allowed values* CW, CCW

**Use:** This register is used to define the direction of the motor. If DIR is set to CW, a positive command will cause the motor to rotate clockwise, facing the motor drive shaft. If DIR is set to CCW, a positive command will cause the motor to rotate counterclockwise, facing the motor drive shaft.

A positive command is defined based on the operating mode as follows:

**Velocity or Torque Mode (MT=TORQ or VEL)**

A positive voltage on the Command Input AI1+ terminal with respect to the AI1- terminal.

**Position Mode (MT=POS)**

The directional conventions stated above assume the pulse inputs conventions as described in the QTX parameter in Chapter 5 represent a positive command.

**NOTE: If the Gearing Numerator (GRN) parameter is negative, the directional conventions will be opposite of those stated above.**

The Axis Status Register (SRA) can be queried from the terminal window to determine the current direction of axis motion. The SRA does **NOT** indicate the current setting for the DIR register.

# EOT

## Encoder Output Type

<b>Class:</b>	Axis Register
<b>Type:</b>	Integer
<b>Syntax:</b>	EOT
<b>Range:</b>	lines per revolution
<i>units</i>	0
<i>default</i>	Encoder Feedback: 0; 500; 625; 1,000; 1,250; 2,000, 2,500
<i>allowed values</i>	Resolver Feedback: 0; 250; 256; 500; 512; 1,000; 1024
<b>Use:</b>	<p>This register sets the output type for the encoder output. When this register is set to zero, the encoder output buffers the auxiliary encoder input pulse for pulse. If the input is a quadrature encoder the output will be quadrature. If the input is CW/CCW pulses the output will be the same format. When the EOT register is non-zero, the encoder output tracks the motor feedback (encoder or resolver) at the resolution set by the EOT value. For encoder-based models the lines per revolution of the motor encoder is 2500 (10,000 counts/revolution) while for the resolver-based models the maximum resolution is 1024 lines per revolution (4096 counts/revolution). The encoder output can use the maximum resolution or divide down this resolution based on the allowed values shown above.</p> <p>The encoder output marker pulse width is fixed at 1/5000<sup>th</sup> of a revolution of the source encoder. This implies that the marker pulse output width will vary with encoder speed and the smallest width will occur at the highest speed. For example, if the source encoder is rotating at 1000 RPM or 16.667 rev/sec then the encoder takes 0.06 seconds per revolution. Therefore, 1/5000<sup>th</sup> of this value, or 12 <math>\mu</math>S, represents the marker pulse width at that speed.</p> <p>There is a 40 nanosecond delay between the encoder input and encoder output signals when EOT=0.</p>
<b>Examples:</b>	
EOT=0	(* encoder output uses the auxiliary encoder input)
EOT=1000	(* encoder output provides 1,000 lines per revolution of the motor)

# FC

## Fault Code

<b>Class:</b>	System Register
<b>Syntax:</b>	FC
<b>Restrictions:</b>	Read only
<b>Use:</b>	The fault code register is used to identify the type of fault that has occurred.
<b>Remarks:</b>	When the FC? command is executed in the terminal window the text message as shown in the table below will be displayed for any active fault codes. If more than one fault code is active, then multiple messages will be displayed. If no fault has occurred, the message given is <i>Controller functional</i> .

Bit	Message	Equivalent LED Display Code
0	Power Failure	PF
1	Reserved	-
2	Reserved	-
3	Lost Enable	LE
4	Reserved	-
5	Excessive Following Error	FE
6	Excessive Command Increment	EI
7	Reserved	-
8	Feedback Lost (Resolver feedback only)	FL
9	Motor Power Over-Voltage	OV
10	Motor Power Clamp Excessive Duty Cycle	EC
11	Reserved	-
12	Motor Over-Current Fault	OC
13	Motor Over-Temperature (Resolver feedback only)	MT
14	Driver Over-Temperature	DT
15	Reserved	-

**FE****Following Error**

<b>Class:</b>	Axis Register
<b>Syntax:</b>	FE
<b>Range:</b>	
<i>units</i>	pulses
<i>minimum</i>	0 pulses
<i>maximum</i>	16,000 pulses
<b>Use:</b>	<p>When the amplifier is configured for position mode, following error is the difference between the instantaneous value of the accumulated difference between the motor position (pulses) and the auxiliary encoder input pulses from the time the electronic gearing was enabled (GRE=1).</p> <p>When the amplifier is configured for velocity mode it is still possible to generate a following error fault. In this mode the amplifier is monitoring feedback pulses/second relative to the commanded position in time. With excessive load conditions, low loop gains, etc. the amplifier may fault on following error. Therefore, the Following Error Bound (FEB) must be increased or the load decreased.</p>
<b>Related Registers:</b>	FEB

**FEB****Following Error Bound**

<b>Class:</b>	Axis Register
<b>Syntax:</b>	FEB
<b>Range:</b>	
<i>units</i>	pulses
<i>defaults</i>	Encoder Feedback: 1,000 pulses Resolver Feedback: 400 pulses
<i>minimum</i>	0 pulses
<i>maximum</i>	16,000 pulses
<b>Use:</b>	<p>The following error bound is a limit set on the following error. If this limit is exceeded, the amplifier will fault and display the FE code on the LED display and in the fault code (FC) register.</p>
<b>Examples:</b>	
FEB=0.5	(* set following error bound)
FEB?	(* report value of following error bound)
<b>Related Registers:</b>	FE

**FI****Fault Input**

<b>Class:</b>	System Register
<b>Syntax:</b>	FI
<b>Restrictions:</b>	Read only.
<b>Use:</b>	The fault input register is used to identify what type of faults are currently active.
<b>Remarks:</b>	When the FI? command is executed from the terminal window, the fault input register value will be given as an English statement as shown in the message column in the table below. If no faults are active, the message given is <i>No fault input is active</i> .

<b>bit</b>	<b>message</b>
0	Feedback lost input active (resolver feedback only)
1	Motor power over-voltage input active
2	Motor power clamp input active
3	Reserved
4	Reserved
5	Motor over-temperature input active
6	Drive over-temperature input active
7–15	Reserved

# FR

## Feedback Resolution

<b>Class:</b>	Axis Register
<b>Syntax:</b>	FR
<b>Range:</b>	
<i>units</i>	pulses/revolution
<i>default</i>	Encoder Feedback: 10,000 Resolver Feedback: 4,096
<i>minimum</i>	500
<i>maximum</i>	1,000,000
<b>Use:</b>	The feedback resolution is defined as the number of feedback pulses per revolution of the motor. The GE Fanuc S-Series motors use a 2500 line encoder, which yields 10,000 quadrature pulses per motor revolution, so the default value should be used. GE Fanuc MTR-Series motors yield 4096 pulses per motor revolution. <b>This parameter must be set before executing the AUTOTUNE function.</b>
<b>Related Commands:</b>	AUTOTUNE

# GRB

## Gearing Bound

<b>Class:</b>	Motion Register
<b>Syntax:</b>	GRB
<b>Range:</b>	
<i>units</i>	pulses/sec
<i>default</i>	0 pulses/sec
<i>minimum</i>	0 pulses/sec
<i>maximum</i>	16,000,000 pulses/sec
<b>Use:</b>	This register sets a bound on the maximum motor pulses/second that the electronic gearing mode can command. If the auxiliary encoder pulse input rate times the GRN/GRD ratio results in a value greater than the bound, then the extra pulses are discarded. When the value of GRB is zero, there is no bound on the electronic gearing command.
<b>Related Registers:</b>	GRN, GRD

# GRD

## Gearing Denominator

**Class:** Motion Register

**Syntax:** GRD

**Range:**

<i>default</i>	1
<i>minimum</i>	1
<i>maximum</i>	10,000

**Use:** The gearing denominator is a parameter used to scale the command input to the amplifier. Typically used in electronic gearing it is defined as the denominator of the gearing ratio between the motor and the gearing input. However, this ratio can also be used to scale the analog command input (AI1) when the amplifier is set to velocity or torque mode. Ratios in the range of 0.0001 to 10,000 can be used. The gearing input is the source connected to the auxiliary encoder input and can be a pulse source or an encoder (see QTX register). The gearing ratio formula is shown below:

**Position mode (MT=POS)**

Motor pulses = gearing input pulses \* GRN/GRD

*Position Mode Example:* The GE Fanuc MTR-Series motors have 4096 pulses/revolution. So, for an application using a 1000 line auxiliary encoder (4000 quadrature pulses) and a gearing ratio of 4096/4000, the motor will make one revolution for each revolution of the master encoder.

$$\begin{aligned} \text{Motor pulses} &= (4000 \text{ gearing pulses/rev}) * 4096/4000 \\ &= 4096 \text{ pulses per auxiliary encoder rev.} \end{aligned}$$

**Torque or Velocity mode (MT=TORO or VEL)**

Command voltage = command voltage input \* (GRN/GRD)

*Velocity Mode Example:* For our application we want to scale the velocity command input so that 10 volts equals 3000 rpm on the motor. The base scaling for the velocity command input is 1228.8 RPM/Volt assuming a gearing ratio of 1. Therefore, we can calculate the required ratio as follows:

$$\begin{aligned} \frac{GRN}{GRD} &= \frac{\text{DesiredScaling}(RPM / Volt)}{\text{BaseScaling}(RPM / Volt)} \\ &= \frac{300}{1228.8} = 0.2441406 \\ &= \frac{1000}{4096} \end{aligned}$$

Therefore, we need to set GRN=1000 and GRD=4096.

*Torque Mode Example:* For our application we want to scale the torque command input so that 5 volts equals 84 in-lb peak torque on an SLM100 motor. The base scaling for the torque command input is 10% Amplifier Peak Current/Volt, assuming a gearing ratio of 1. Therefore, we can calculate the required scaling ratio as follows:

The peak torque rating of the S-Series motor shown in the specifications in Chapter 2 generally equates to the full peak current rating of the amplifier recommended for use with that motor. Therefore, the SLM100 motor peak rating of 84 in-lb would normally be produced at 100% of the SSD107 amplifier's peak current rating. This means that percent current is the same as percent torque, so we can use the two factors interchangeably. From the base scale factor we know that 100% peak current = 10 Volts and this is the same as 100% peak torque = 10 Volts. But we need to generate 100% current at 5 Volts. The following equation can be used to determine the correct scaling ratio:

$$\begin{aligned} \frac{GRN}{GRD} &= \frac{DesiredScaling(\%PeakTorque/Volt)}{BaseScaling(\%PeakTorque/Volt)} \\ &= \frac{100\%/5Volts}{10\%/Volt} = 2 \end{aligned}$$

Therefore, we need to set GRN=2 and GRD=1.

**Note: To change the direction the motor rotates relative to the gearing or analog command input, use a negative value for the GRD parameter or change the direction parameter (DIR) to the opposite value (CW if set to CCW or vice versa).**

***Related Registers:***

GRN, GRE, QTX, MT

## GRE

### Gearing Enable

<b>Class:</b>	Motion Register
<b>Syntax:</b>	GRE
<b>Range:</b>	
<i>default</i>	0
<i>allowed values</i>	0, 1
<b>Use:</b>	The gearing enable is used to enable the use of the GRN/GRD scaling ratio for either electronic gearing (if MT=POS) or for the analog command input AI1 (if MT=TORQ or VEL). If GRE is set to 1, electronic gearing or command scaling is enabled. If GRE is set to 0, it is disabled.
<b>Registers Used:</b>	GRD, GRI, GRN, GRB, GRF, MT

## GRF

### Gearing Filter Constant

<b>Class:</b>	Motion Register
<b>Syntax:</b>	GRF
<b>Range:</b>	
<i>default</i>	0
<i>minimum</i>	0
<i>maximum</i>	8
<b>Use:</b>	The gearing filter constant is used to filter (smooth) the electronic gearing command output. The amount of filtering increases by the value as a power of two from 0 (no filter) to 8 (a filter of 256 samples).
<b>Related Registers:</b>	GRB, GRN, GRD

# GRI

## Gearing Input Source Selection

<b>Class:</b>	Motion Register
<b>Syntax:</b>	GRI
<b>Range:</b>	
<i>default</i>	PSX
<i>allowed values</i>	FREQ 2048 pulses/sec PSX auxiliary encoder input
<b>Restrictions:</b>	Valid only in position mode (MT=POS)
<b>Use:</b>	<p>The gearing input is used when the electronic gearing mode is enabled (GRE=1) to define the command source for the gearing input. When set to PSX, the gearing function will follow pulses input on the auxiliary encoder input. When set to FREQ, the gearing function will follow a fixed frequency internal oscillator. This mode is useful for jogging the motor during start-up and system validation. By changing the gearing ratio (GRN/GRD) from the terminal window, you can vary the motor speed.</p> <p>In both cases the following rate of the axis motor is determined based on the selected source input rate multiplied by the gearing ratio as shown below:</p> <p>Motor pulses = gearing input pulses * GRN/GRD.</p>
<b><i>Related Registers:</i></b>	GRD, GRE, GRN, GRB

# GRN

## Gearing Numerator

<b>Class:</b>	Motion Register
<b>Syntax:</b>	GRN
<b>Range:</b>	
<i>default</i>	1
<i>minimum</i>	-10,000
<i>maximum</i>	10,000
<b>Use:</b>	The gearing numerator is a parameter used to scale the command input to the amplifier. Typically used in electronic gearing, it is defined as the numerator of the gearing ratio between the motor and the gearing input. However, this ratio can also be used to scale the analog command input (AII) when the amplifier is set to velocity or torque mode. Ratios in the range of 0.0001 to 10,000 can be used. The gearing input is the source connected to the auxiliary encoder input and can be a pulse source or an encoder (see QTX register). The gearing ratio formula is shown below:

### **Position mode (MT=POS)**

Motor pulses = gearing input pulses \* GRN/GRD

*Position Mode Example:* The GE Fanuc S-Series motors have 10,000 pulses/revolution. So, for an application using a 1000 line auxiliary encoder (4000 quadrature pulses) and a gearing ratio of 10,000/4000, the motor will make one revolution for each revolution of the master encoder.

$$\begin{aligned} \text{Motor pulses} &= (4000 \text{ gearing pulses/rev}) * 10,000/4000 \\ &= 10,000 \text{ pulses per auxiliary encoder rev.} \end{aligned}$$

### **Torque or Velocity mode (MT=TORQ or VEL)**

Command voltage = command voltage input \* (GRN/GRD)

*Velocity Mode Example:* For our application we want to scale the velocity command input so that 10 volts equals 3000 rpm on the motor. The base scaling for the velocity command input is 1228.8 RPM/Volt assuming a gearing ratio of 1. Therefore, we can calculate the required ratio as follows:

$$\begin{aligned} \frac{GRN}{GRD} &= \frac{\text{DesiredScaling}(RPM / Volt)}{\text{BaseScaling}(RPM / Volt)} \\ &= \frac{300}{1228.8} = 0.2441406 \\ &= \frac{1000}{4096} \end{aligned}$$

Therefore, we need to set GRN=1000 and GRD=4096.

*Torque Mode Example:* For our application we want to scale the torque command input so that 5 volts equals 84 in-lb peak torque on an SLM100 motor. The base scaling for the torque command input is 10% Amplifier Peak Current/Volt, assuming a gearing ratio of 1. Therefore, we can calculate the required scaling ratio as follows:

The peak torque rating of the S-Series motor shown in the specifications in Chapter 2 generally equates to the full peak current rating of the amplifier recommended for use with that motor. Therefore, the SLM100 motor peak rating of 84 in-lb would normally be produced at 100% of the SSD107 amplifier's peak current rating. This means that percent current is the same as percent torque, so we can use the two factors interchangeably. From the base scale factor we know that 100% peak current = 10 Volts and this is the same as 100% peak torque = 10 Volts. But we need to generate 100% current at 5 Volts. The following equation can be used to determine the correct scaling ratio:

$$\frac{GRN}{GRD} = \frac{DesiredScaling(\%PeakTorque/Volt)}{BaseScaling(\%PeakTorque/Volt)}$$

$$= \frac{100\%/5Volts}{10\%/Volt} = 2$$

Therefore, we need to set GRN=2 and GRD=1.

**Note: to change the direction the motor rotates relative to the gearing or analog command input, use a negative value for the GRD parameter or change the direction parameter (DIR) to the opposite value (CW if set to CCW or vice versa).**

***Related Registers:***

GRD, GRE, GRI, GRF, GRB

**IO****General I/O**

**Class:** Input/Output Register

**Syntax:** IO

**Restrictions:** Read only.

**Use:** The general I/O register is used to identify what inputs and outputs are active.

**Remarks:** When the IO? command is executed, the general I/O register will be given as an English statement that says what inputs or outputs, if any, are active. If none of the inputs or outputs are active, the message given is *No I/O is active*.

bit	message
0	Reserved
1	Reserved
2	Reserved
3	Reserved
4	Auxiliary channel A input active
5	Auxiliary channel B input active
6	Reserved
7	Marker input active
8	Reserved
9	Reserved
10	Reserved
11	Enable input active
12	Reserved
13	Reserved
14	Reserved
15	OK output active

**Related Registers:** DI, DO, CIE

**KD****Derivative Control Gain**

**Class:** Axis Register

**Syntax:** KD

**Range:**

*default*

Encoder Feedback: 200

Resolver Feedback: 500

*minimum*

0

*maximum*

8,000

**Use:**

The derivative control gain is used to multiply the time derivative of the following error to control the position of the motor. The equation for setting KD based on the torque to inertia ratio and the axis feedback resolution (FR) is:

$$KD = \frac{316,022,860}{FR} \times \frac{1}{\sqrt{\frac{\text{torque}}{\text{inertia}}}}$$

where torque is the continuous torque of the motor in in-lbs, and inertia is the system inertia in in-lb-sec<sup>2</sup>. This value along with the values of all the other tuning parameters can be set automatically by the AUTOTUNE command.

**Related Registers:**

FR, AUTOTUNE

# KI

## Integral Control Gain

**Class:** Axis Register

**Syntax:** KI

**Range:**

<i>default</i>	0
<i>minimum</i>	0
<i>maximum</i>	64,000

**Use:** The integral control gain is used to multiply the time integral of the following error to control the position of the axis. The equation for setting KI based on the torque to inertia ratio and the axis feedback resolution (FR) is:

$$KI = \frac{686,310}{FR} \times \sqrt{\frac{\text{torque}}{\text{inertia}}}$$

where torque is the continuous torque of the motor in in-lbs and inertia is the system inertia in in-lb-sec<sup>2</sup>. This value along with the values of all the other tuning parameters can be set automatically by the AUTOTUNE command.

**Related Registers:** FR

**Related Commands:** AUTOTUNE

## KL

## Motor Inductance

**Class:** Axis Register

**Syntax:** KL

**Range:**

*units* mH  
*default* 4 mH  
*minimum* 1 mH  
*maximum* 100 mH

**Use:** The motor inductance is used to tune the digital current controller to the attached motor. S2K drives are designed to operate with a minimum line-line inductance of 2 mH. This register should be set to the motor's **line-line** inductance in mH—use the following table for your KL values:

GE Fanuc Motor	KL Value	GE Fanuc Motor	KL Value	GE Fanuc Motor	KL Value
SLM003	5	MTR-3S32-G	23	MTR-3T42-G	26
SLM005	6	MTR-3S33-G	22	MTR-3T42-H	8
SLM010-115V	3	MTR-3S33-H	6	MTR-3T43-G	20
SLM010-230V	10	MTR-3S34-G	30	MTR-3T43-H	13
SLM020-115V	6	MTR-3S35-G	42	MTR-3T43-I	3
SLM020-230V	16	MTR-3S43-G	53	MTR-3T43-J	5
SLM040-115V	4	MTR-3S43-H	13	MTR-3T44-G	27
SLM040-230V	10	MTR-3S45-G	20	MTR-3T44-H	12
SLM070	6	MTR-3S45-H	5	MTR-3T44-I	4
SLM100	4	MTR-3S46-G	25	MTR-3T44-J	7
SDM100	10	MTR-3S46-H	6	MTR-3T45-G	33
SDM250	4	MTR-3S63-G	9	MTR-3T45-H	8
SLM250	2	MTR-3S63-H	2	MTR-3T45-I	4
SLM350	2	MTR-3S65-G	13	MTR-3T53-G	15
SLM500	1	MTR-3S65-H	3	MTR-3T53-H	7
SDM500	2	MTR-3S67-G	18	MTR-3T54-G	16
SGM450	4	MTR-3S67-H	4	MTR-3T54-H	7
MTR-3N21-G	14	MTR-3S84-G	3	MTR-3T55-G	20
MTR-3N21-H	4	MTR-3S86-G	3	MTR-3T55-H	8
MTR-3N22-H	5	MTR-3S88-G	4	MTR-3T55-I	2
MTR-3N24-G	9	MTR-3T11-G	7	MTR-3T57-G	13
MTR-3N31-H	10	MTR-3T12-G	4	MTR-3T57-H	3
MTR-3N32-G	18	MTR-3T13-G	2	MTR-3T65-G	20
MTR-3N32-H	4	MTR-3T21-G	10	MTR-3T66-G	24
MTR-3N33-G	22	MTR-3T22-G	7	MTR-3T66-H	6
MTR-3N33-H	4	MTR-3T23-G	10	MTR-3T67-G	7
MTR-3S22-G	21	MTR-3T24-H	7	MTR-3T69-G	10
MTR-3S23-G	26	MTR-3T24-I	4		

---

**KP****Proportional Control Gain**

---

**Class:** Axis Register

**Syntax:** KP

**Range:**  
*default* 10  
*minimum* 0  
*maximum* 8,000

**Use:** The proportional control gain is used to multiply the following error to control the position of the axis. The equation for setting KP based on the axis feedback resolution (FR) is:

$$KP = \frac{327,680}{FR}$$

Since FR is 10,000 for the S-Series motor encoders, KP should be set to 32. For MTR-Series motors FR=4096 and Kp should be set to 80. This value, along with the values of all the other tuning gains, can be set automatically by the AUTOTUNE command.

**Related Registers:** FR, AUTOTUNE

**KT****Filter Time Constant****Class:** Axis Register**Syntax:** KT**Range:***default*

Encoder Feedback: 3

Resolver Feedback: 1

*minimum*

0

*maximum*

5

**Use:**

The filter time constant is used to eliminate dither. Generally, the lower the bandwidth of a servo system, the higher the filter time constant should be. The equation for setting KT based on the torque to inertia ratio is:

**Encoder Feedback:**

$$KT = \left\lfloor \frac{280}{\sqrt{\frac{\text{torque}}{\text{inertia}}} + 0.5 \right\rfloor$$

**Resolver Feedback:**

$$KT = \left\lfloor \frac{120}{\sqrt{\frac{\text{torque}}{\text{inertia}}} + 0.5 \right\rfloor$$

where torque is the continuous torque of the motor in in-lbs, and inertia is the system inertia in in-lb-sec<sup>2</sup>. The brackets mean to take the integer part of the number only. This value along with the values of all the other control constants can be set automatically by the AUTOTUNE command.

**Related Commands:**

AUTOTUNE

---

## MOTORSET Automatically Sets Up Motor Constants

---

<b>Class:</b>	System Command
<b>Syntax:</b>	MOTORSET
<b>Use:</b>	This command automatically sets up the motor Commutation Angle Offset (CMO) and Motor Poles to Resolver Poles Commutation Ratio (CMR) parameters. These registers are set automatically when you select a GE Fanuc motor and S2K drive from the Motion Expert wizard in the Motion Developer software. Normally this command should only be executed to determine CMO and CMR for a non-GE Fanuc resolver-based motor or to confirm that a GE Fanuc motor is properly configured when troubleshooting a system.
<b>Remarks:</b>	<p>This command will execute only when the controller is faulted, the axis <i>Enable</i> input is true, and no programs or motion blocks are executing. <b>The motor must not be connected to a load when you use this command.</b></p> <p>To execute MOTORSET use the following procedure:</p> <ol style="list-style-type: none"><li>1. Ensure that the motor is <b>NOT</b> connected to the load</li><li>2. Set the Enable input to false</li><li>3. Type MOTORSET &lt;Enter&gt; in the terminal window</li><li>4. Set the Enable input true within 10 seconds</li><li>5. When complete, the drive will fault due to lost enable (LE)</li></ol> <p>When executed, it causes the motor rotor to line up with two locations of the stator vector. This command must be executed from the terminal window and takes from 2 to 30 seconds to execute; when finished, the controller or system will return either an asterisk (*) indicating successful completion, or a question mark and the following error message:</p> <p>SWITCH MOTOR LEADS — two motor leads should be switched.</p>
<b>Related Commands:</b>	AUTOTUNE
<b>Registers Used:</b>	CMO, CMR, CURC

**MT****Motion Type**

<b>Class:</b>	Motion Register
<b>Syntax:</b>	MT
<b>Range:</b> <i>default</i> <i>allowed values</i>	TORQ VEL (velocity mode) POS (position mode) TORQ (torque mode)
<b>Use:</b>	The motion type register is used to define the operating mode of the amplifier. In torque mode the amplifier uses the command analog input (A11) to control the amount of torque the motor will generate. In position mode the amplifier uses the auxiliary encoder input (IN_A and IN_B) to control the position of the motor shaft using electronic gearing (following). In velocity mode the analog command input (A11) is used to control the velocity of the motor.
<b>Examples:</b>	MT=VEL (* set motion type to velocity) MT? (* report motion type for the amplifier)

**Q****Reports Value of Register**

<b>Class:</b>	Diagnostic Command	
<b>Syntax:</b>	<i>pIQ</i> (e.g., SRAQ, FCQ)	
<b>Parameters:</b> <i>pI</i>	<i>allowed values</i> any register	<i>description</i> register
<b>Use:</b>	This command is used to report the value of any register. It works exactly the same as the “?” command.	
<b>Related Commands:</b>	?	

## QTX

### Auxiliary Encoder Type

<b>Class:</b>	Axis Register
<b>Syntax:</b>	QTX
<b>Range:</b>	Q4
<i>default</i>	Q4 (quadrature x4)
<i>allowed values</i>	PD (pulse/direction) CW (clockwise/counterclockwise)
<b>Use:</b>	This register is used to define the signal type for the auxiliary encoder input. The possibilities are listed below:
<i>Q4 (quadrature x4)</i>	Sets the input for two pulse waveforms in quadrature with a pulse multiplier of 4.
<i>PD (pulse/direction)</i>	Sets the input for a pulse input on channel A and a direction input on channel B.
<i>CW (CW/CCW)</i>	Sets the input for a pulse input on channel A for CW motion and a pulse input on channel B for CCW motion.
<b>Remarks:</b>	With DIR=CW the auxiliary encoder output will cause the motor to move in the clockwise direction (viewing into the shaft) when: <ol style="list-style-type: none"> <li>1) QTX=Q4 and channel A leads channel B</li> <li>2) QTX=PD and channel B+ &gt; channel B-</li> <li>3) QTX=CW and channel A has a pulse waveform and channel B does not.</li> </ol>

## REVISION

### Reports Firmware Revision

<b>Class:</b>	Diagnostic Command
<b>Syntax:</b>	REVISION
<b>Use:</b>	This command reports the revision of the amplifier firmware in the terminal window. The response looks similar to the following: <p style="margin-left: 40px;"><i>IC800SSD104S1A Revision 2.4 © 2000 Whedco, Inc.</i> <i>IC800SSD104RS1A Revision 2.4 © 2000 Whedco, Inc.</i></p>

# SRA

## Axis Status

<b>Class:</b>	System Register
<b>Syntax:</b>	SRA
<b>Restrictions:</b>	Read only
<b>Use:</b>	The axis status register is used to determine the status of the axis.
<b>Remarks:</b>	When the SRA? command is executed from the terminal window the text message as shown in the table below will be displayed for any active conditions.

Bit	Message
0	Axis moving
1	Gearing enabled
2	Reserved
3	Reserved
4	Reserved
5	Reserved
6	Reserved
7	Axis direction forward
8	Reserved
9	Axis at torque limit
10	Reserved
11	Reserved
12	Reserved
13	AXIS FAULT
14	Reserved
15	Reserved

## STEP

---

### Step Input

---

<b>Class:</b>	Motion Command	
<b>Syntax:</b>	STEP <i>p1</i> (e.g., STEP100)	
<b>Parameters:</b> <i>p1</i>	<i>allowed values</i> -16,000 through 16,000	<i>description</i> number of pulses
<b>Use:</b>	This command applies a step command input to the amplifier. This command can be useful when tuning the amplifier response to a step input.	
<b>Remarks:</b>	The step input cannot be larger than the following error bound, FEB or a following error fault will occur when the command is executed.	
<b>Related Registers:</b>	FEB	

# TLC

## Torque Limit Command

<b>Class:</b>	Axis Register
<b>Syntax:</b>	TLC
<b>Range:</b>	
<i>units</i>	%
<i>default</i>	100.0
<i>minimum</i>	1.0
<i>maximum</i>	100.0
<b>Use:</b>	<p>This command sets the torque (current) limit as a percentage of the amplifier's continuous current setting, CURC.</p> <p>For example, if CURC is set to 55% and TLC is set to 100% on the SSD104 amplifier, the amplifiers maximum current output is limited to 2.37 amps (0.55 x 4.3 A). Now, if TLC is reduced to 50%, the amplifier will be further limited to 1.18 amps continuous (0.5 x 2.37 A). TLC can only scale torque to values between 0 – 100% of the motors continuous torque rating.</p>
<b>Remarks:</b>	<p>The torque limit is enabled by the TLE command.</p> <p><b>NOTE: Servo motors translate current from the amplifier into torque at the motor's shaft based on a winding factor called the <i>Torque Constant</i>. Because there are manufacturing variations from motor to motor (even of the same part number), this conversion factor can vary as much as <math>\pm 10\%</math> from the nominal values shown in Chapter 2 – Motor Specifications. For an application requiring torque limiting better than this tolerance, an in-line torque transducer is required.</b></p> <p>The Axis Status Register (SRA) can be queried from the terminal window to determine if the axis is at the torque limit.</p>
<b>Related Registers:</b>	TLE, CURC

# TLE

## Torque Limit Enable

**Class:** Axis Register

**Syntax:** TLE

**Range:**  
*default* 0  
*allowed values* 0, 1, 2

**Use:** This command is used to enable the torque limit. If TLE is set to 1, then the torque limit is enabled and the amplifier current will be restricted based on the set value for the Torque Limit Command (TLC). If TLE is set to 0, the torque limit is disabled. When TLE = 2 the torque limit is set by the absolute value of analog input 2 (AI2) with a scale factor as follows:

$$10V \text{ on AI2} = \text{Amplifier } \underline{\text{Full}} \text{ Continuous Current Rating}$$

The word Full implies any limit imposed by the CURC parameter is NOT used by the analog torque limit input.

The Axis Status Register (SRA) can be queried from the terminal window to determine if gearing is enabled.

**Registers Used:** TLC, AI

# Chapter 6

## Diagnostics

### 6.1 LED Display Status Codes

The S2K Series drives are equipped with a two-digit LED status display on the front panel. The drive will display all active codes in a round robin fashion. The status register will display OK when there are no faults and the drive is in an operational mode.

**Table 6-1. LED Display Status Codes**

Display Code	Status	Description
OK	okay	Drive enabled, CPUs and operating system functional
CC	faulted	Motor power clamp over current
DT	faulted	Drive over temperature
EC	faulted	Motor power clamp excessive duty cycle
EI	faulted	Excessive command increment
FL	faulted	Feedback lost
FE	faulted	Excess following error
LE	faulted	Lost enable
MT	faulted	Motor over temperature (resolver feedback only)
OC	faulted	Motor over current
OV	Faulted	Motor over voltage
PF	faulted	Power failure (occurs each time the amplifier is energized)
.	Ok/faulted	Flashing decimal indicates serial communication is occurring

For example, if the drive is faulted due to FE and LE, the unit will alternately display FE, LE... FE, LE... etc.

Faults are reset using the Enable input. When a fault occurs, the Enable input must make a logic low to logic high transition to clear the faults.

## 6.2 Status Register Messages

The S2K amplifiers have the following status registers that can provide valuable information on the current state of system resources:

- Fault Code (FC) Register
- Axis Status Register (SRA)

The contents of any status register can be queried using either the terminal window in the Motion Developer software or other VT100-compliant terminal emulation program such as Windows Hyper Terminal. The following tables show the contents of each status register. Also, see Chapter 5 for descriptions of the register commands.

### 6.2.1 Fault Code Register (FC)

Bit	System Fault Code Message	Possible Cause(s)	Possible Solution(s)
All Bits Set To Zero	Amplifier Functional	The amplifier is not faulted and is enabled.	Continue with normal operation
0	Power Failure	A power failure has occurred. This fault always occurs when the system is powered-up.	Cycle the enable input from low to high to reset the fault condition.
1	Reserved		
2	Reserved		
3	Lost Enable	The enable discrete input was deactivated.	Reactivate the enable input.
4	Reserved		
5	Excessive Following Error	The axis Following Error (FE) was greater than the Following Error Bound (FEB) limit. This error can occur regardless of the amplifier operating mode configured by the Motion Type (MT) parameter.	Make sure that the tuning parameters are set up properly. Make sure that the motor encoder feedback wiring is correct. Make sure that the motor has sufficient torque for the commanded motion profiles.
6	Excessive Command Increment	The program simultaneously executed too many motions.	Make sure that the program does not execute too many motions simultaneously.
7	Reserved		
8	Reserved		
9	Motor Power Over-Voltage	The amplifier DC bus voltage was greater than 475 Vdc.	The regeneration circuit did not function correctly. Make sure that the wiring is correct. If applicable, an external regeneration resistor may be required
10	Motor Power Clamp Excessive Duty Cycle	The internal regeneration circuit was operated past its continuous rating: SSD104 & SSD107: 25 Watt SSD216 & SSD228: 50 Watt	Reduce deceleration rate, maximum velocity or connected load inertia. If applicable, add an external regeneration resistor with greater capacity. Make sure that the resistor value is at least 50 ohms.
11	Reserved		

Bit	System Fault Code Message	Possible Cause(s)	Possible Solution(s)
12	Motor Over-Current Fault	The external regeneration clamp resistor is shorted (SSD216 or SSD228 models only) or the amplifier was putting out excessive current through the motor leads.	Make sure the resistor leads are not shorted. Check the wiring of the motor leads. Make sure that the motor leads are not shorted.
13	Reserved		
14	Drive Over-Temperature	The temperature of the amplifier heat sink was greater than 80°C.	Check the amplifier for adequate air flow and proper clearance around heat sink. Check enclosure for excessive ambient temperature. Additional cabinet cooling or amplifier fan cooling may be required.
15	Reserved		

## 6.2.2 Fault Input Register (FI)

Bit	Fault Input Message	Possible Solution(s)
All Bits Set To Zero	No fault input active	There are no currently active fault inputs.
0	Feedback lost input active (resolver feedback only)	The motor feedback for resolver-based models has been lost due to broken wires, connections, a failed resolver or resolver receiving circuit
1	Motor power over-voltage input active	The controller DC bus voltage is greater than 475 Vdc for drives rated 115/230 or 230 VAC. For models rated 460 VAC this input is active when the DC bus voltage exceeds 855 Vdc.
2	Motor power clamp input active	The internal regeneration circuit is on.
3	Reserved	
4	Reserved	
5	Motor over-temperature input active	The motor thermal protector is an open circuit The S2K is designed for use with normally-closed motor thermal switches or positive-temperature-coefficient (PTC) thermistor devices. If PTC device is used it should exhibit a resistance less than 1,000 ohms at acceptable motor operating temperatures and greater than 10,000 ohms at temperatures that exceed the motors thermal rating. All GE Fanuc MTR-Series motors include a PTC thermistor that should be connected to the appropriate terminals on the <i>Position Feedback</i> connector.
6	Drive over-temperature input active	The temperature of the controller heat sink is greater than 80° C.
7 - 15	Reserved	

### 6.2.3 General I/O Register (IO)

Bit	General I/O Message	Description
All Bits Set To Zero	No I/O is active	None of the I/O in this table is active.
0	Reserved	
1	Reserved	
2	Reserved	
3	Reserved	
4	Auxiliary channel A input active	Channel A of the auxiliary encoder is active.
5	Auxiliary channel B input active	Channel B of the auxiliary encoder is active.
6	Reserved	
7	Marker input active	The index input of the motor encoder is active.
8	Reserved	
9	Reserved	
10	Reserved	
11	Enable input active	The enable input is active.
12	Reserved	
13	Reserved	
14	Reserved	
15	OK output active	The OK output is active.

## 6.2.4 Axis Status Register (SRA)

Bit	Axis Status Message	Description
0	Reserved	
1	Gearing enabled	Electronic gearing is enabled (GRE=1).
2	Reserved	
3	Reserved	
4	Reserved	
5	Reserved	
6	Reserved	
7	Axis direction forward	The axis is moving or has last moved in the forward direction. When this bit is set to zero the axis is moving or has last moved in the reverse direction.
8	Reserved	
9	Axis at torque limit	The Torque Limit Enable (TLE) parameter is enabled and the axis is at the torque limit set by the Torque Limit Current (TLC) parameter.
10	Reserved	
11	Reserved	
12	Reserved	
13	AXIS FAULT	A fault specific to the axis has occurred.
14	Reserved	
15	Reserved	

## 6.3 Query Registers for Current Data (Q, ?)

The query commands (Q or ?) for the terminal window displays the current state of almost any parameter while the amplifier is operating. The value displayed is a one-time “snapshot” for that instant in time. To view the value again the query command must be executed again. For example:

\*FC?                   (query the Fault Code register)

\* Lost enable        -terminal window displays the lost enable error message

## 6.4 Troubleshooting Flow Chart

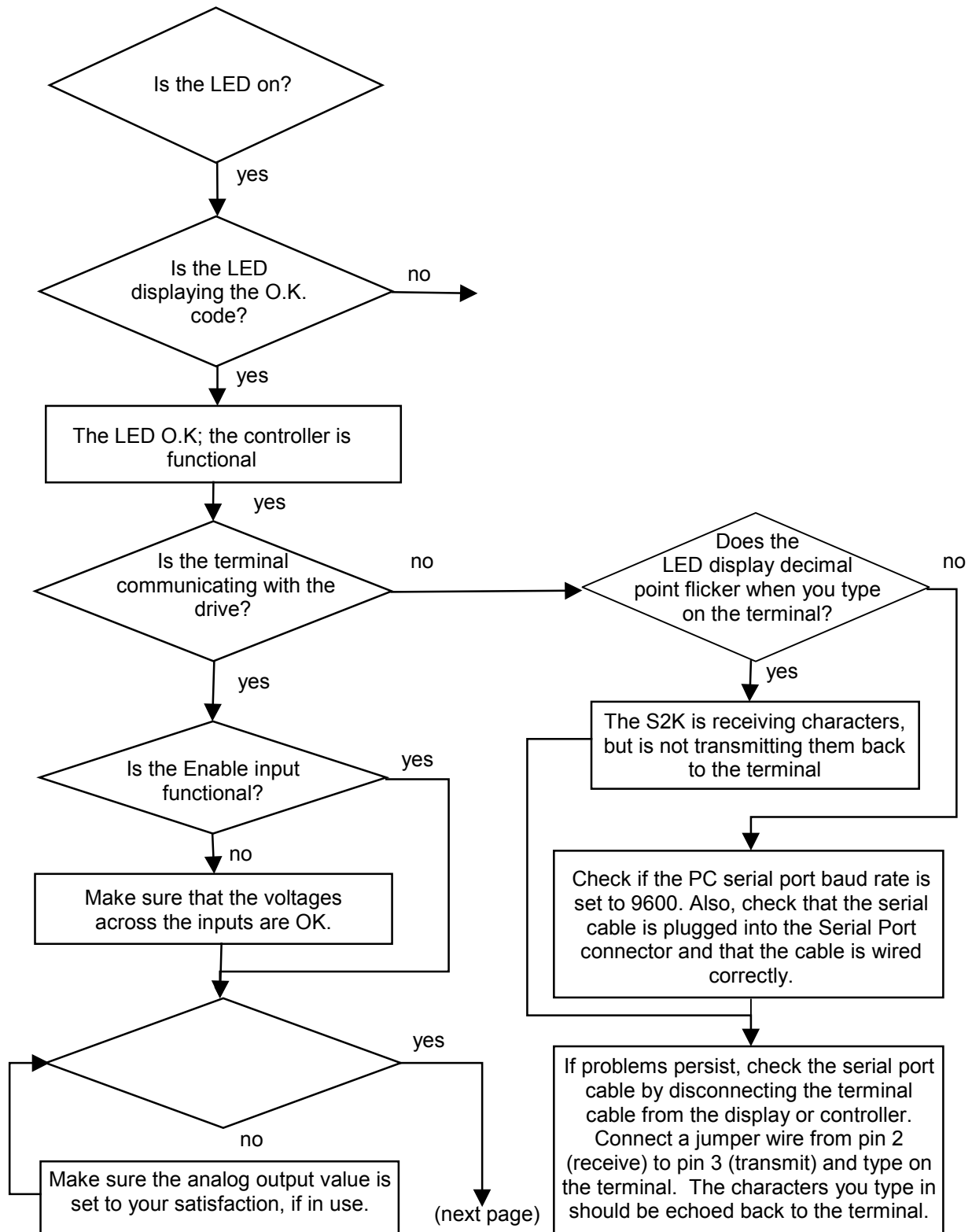

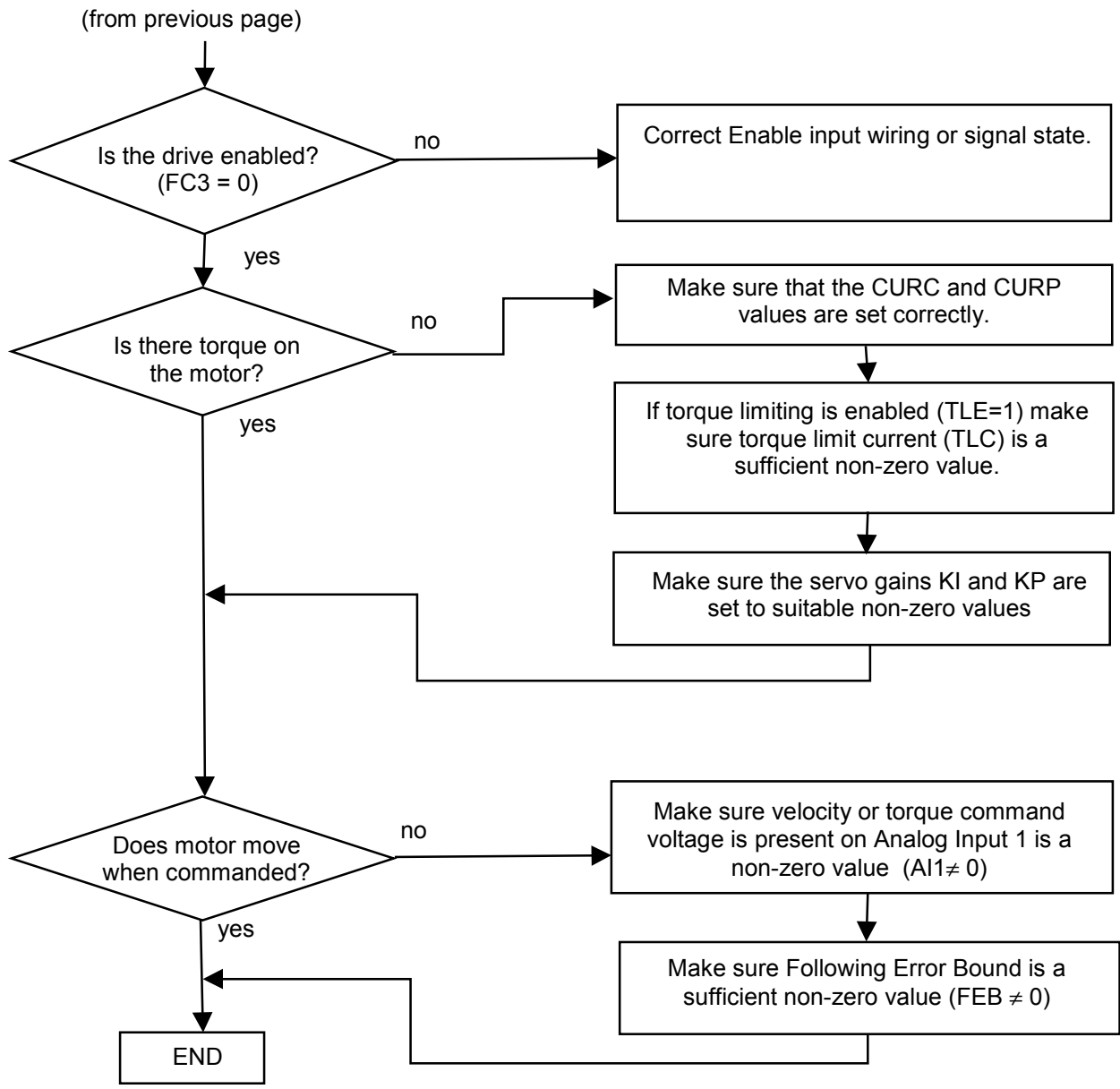

Appendix

A

Tables and Formulas

**Standard ASCII (American Standard Code for Information Interchange) Codes**

Char.	Dec.	Hex.	Char.	Dec.	Hex.	Char.	Dec.	Hex.
NUL	0	00	+	43	2B	V	86	56
SOH	1	01	,	44	2C	W	87	57
STX	2	02	-	45	2D	X	88	58
ETX	3	03	.	46	2E	Y	89	59
EOT	4	04	/	47	2F	Z	90	5A
ENQ	5	05	0	48	30	[	91	5B
ACK	6	06	1	49	31	\	92	5C
BEL	7	07	2	50	32	]	93	5D
BS	8	08	3	51	33	^	94	5E
HT	9	09	4	52	34	~	95	5F
LF	10	0A	5	53	35	`	96	60
VT	11	0B	6	54	36	a	97	61
FF	12	0C	7	55	37	b	98	62
CR	13	0D	8	56	38	c	99	63
SO	14	0E	9	57	39	d	100	64
SI	15	0F	:	58	3A	e	101	65
DLE	16	10	;	59	3B	f	102	66
DC1	17	11	<	60	3C	g	103	67
DC2	18	12	=	61	3D	h	104	68
DC3	19	13	>	62	3E	i	105	69
DC4	20	14	?	63	3F	j	106	6A
NAK	21	15	@	64	40	k	107	6B
SYN	22	16	A	65	41	l	108	6C
ETB	23	17	B	66	42	m	109	6D
CAN	24	18	C	67	43	n	110	6E
EM	25	19	D	68	44	o	111	6F
SUB	26	1A	E	69	45	p	112	70
ESC	27	1B	F	70	46	q	113	71
FS	28	1C	G	71	47	r	114	72
GS	29	1D	H	72	48	s	115	73
RS	30	1E	I	73	49	t	116	74
US	31	1F	J	74	4A	u	117	75
SP	32	20	K	75	4B	v	118	76
!	33	21	L	76	4C	w	119	77
”	34	22	M	77	4D	x	120	78
#	35	23	N	78	4E	y	121	79
\$	36	24	O	79	4F	z	122	7A
%	37	25	P	80	50	{	123	7B
&	38	26	Q	81	51		124	7C
'	39	27	R	82	52	}	125	7D
(	40	28	S	83	53	~	126	7E
)	41	29	T	84	54	“	127	7F
*	42	2A	U	85	55			

## AWG to Metric Wire Size Conversion

Since there is not an exact correspondence between American AWG wire sizes and metric sizes, the metric values in the following table are close approximations. If you need greater precision, contact your wire supplier.

AWG to Metric Wire Size Conversion	
AWG Size	Metric Cross Section in square millimeters (mm <sup>2</sup> )
1	42.4
2	33.6
4	21.2
6	13.2
8	8.37
10	5.26
12	3.31
14	2.08
16	1.31
18	0.82
20	0.52
22	0.32
24	0.21
26	0.13
28	0.081
30	0.051

# Temperature Conversion

## Formulas

$$^{\circ}\text{C} = 5/9(^{\circ}\text{F} - 32)$$

$$^{\circ}\text{F} = (9/5 \times ^{\circ}\text{C}) + 32$$

## Table

Celsius to Fahrenheit Conversion (to nearest degree)					
Degrees Celsius	Degrees Fahrenheit	Degrees Celsius	Degrees Fahrenheit	Degrees Celsius	Degrees Fahrenheit
-50	-58	50	122	145	293
-45	-49	55	131	150	302
-40	-40	60	140	155	311
-30	-22	65	149	160	320
-25	-13	70	158	165	329
-20	-4	75	167	170	338
-15	5	80	176	175	347
-10	14	85	185	180	356
-5	23	90	194	185	365
0	32	95	203	190	374
5	41	100	212	195	383
10	50	105	221	200	392
15	59	110	230	205	401
20	68	115	239	210	410
25	77	120	248	215	419
30	86	125	257	220	428
35	95	130	266	225	437
40	104	135	275	230	446
45	113	140	284	235	455

## Miscellaneous Equivalents

1 ounce (weight) =	28.35 grams
1 pound (weight) =	453.6 grams
1 pound (weight) =	16 ounces
1 pound (force) =	4.448 newtons
1 short ton (weight)=	907.2 kilograms
1 short ton (weight)=	2,000 pounds
1 horsepower (power)=	550 foot-pounds per second
1 horsepower (power) =	746 watts of electrical power
1 kilowatt (power) =	1.341 horsepower
1 kilowatt-hour (energy or work) =	3,412.142 Btu
1 kilowatt-hour (energy or work) =	1,000 watts/hr.
1 watt (power) =	3.412 Btu/hr.
1 watt (power) =	1 joule/sec.
1 joule/sec. (power) =	1 watt
1 joule (energy)=	1 newton-meter
1 Btu =	0.293 watt
1 Btu =	778.2 foot-pounds
1 Btu =	252 gram-calories
1 Btu (energy)=	1055 joules
1 newton-meter (torque or work) =	0.7376 pound-feet
1 newton-meter (torque or work) =	8.851 pound-inches
1 pound-foot (torque or work) =	1.3558 newton-meters
1 pound-inch (torque or work) =	0.113 newton-meters
1 ounce-inch (torque or work) =	72 gram-centimeters
1 degree (angular) =	0.0175 radians
1 minute (angular) =	0.01667 degrees
1 radian (angular) =	57.3 degrees
1 quadrant (angular) =	90 degrees

## Fraction-Decimal-Metric Equivalents

Fraction (Inch)	Decimal (Inch)	Metric (mm)
1/64	0.01562	0.397
1/32	0.03125	0.794
3/64	0.04688	1.191
1/16	0.06250	1.588
5/64	0.07812	1.984
3/32	0.09375	2.381
7/64	0.10938	2.778
1/8	0.12500	3.175
9/64	0.14062	3.572
5/32	0.15625	3.969
11/64	0.17188	4.366
3/16	0.18750	4.763
13/64	0.20312	5.159
7/32	0.21875	5.556
15/64	0.23438	5.953
1/4	0.25000	6.350
17/64	0.26562	6.747
9/32	0.28125	7.144
19/64	0.29688	7.541
5/16	0.31250	7.938
21/64	0.32812	8.334
11/32	0.34375	8.731
23/64	0.35938	9.128
3/8	0.37500	9.525
25/64	0.39062	9.922
13/32	0.40625	10.319
27/64	0.42188	10.716
7/16	0.43750	11.113
29/64	0.45312	11.509
15/32	0.46875	11.906
31/64	0.48438	12.303
1/2	0.50000	12.700

Fraction (Inch)	Decimal (Inch)	Metric (mm)
33/64	0.51562	13.097
17/32	0.53125	13.494
35/64	0.54688	13.891
9/16	0.56250	14.288
37/64	0.57812	14.684
19/32	0.59375	15.081
39/64	0.60938	15.478
5/8	0.62500	15.875
41/64	0.64062	16.272
21/32	0.65625	16.669
43/64	0.67188	17.066
11/16	0.68750	17.463
45/64	0.70312	17.859
23/32	0.71875	18.256
47/64	0.73438	18.653
3/4	0.75000	19.050
49/64	0.76562	19.447
25/32	0.78125	19.844
51/64	0.79688	20.241
13/16	0.81250	20.638
53/64	0.82812	21.034
27/32	0.84375	21.431
55/64	0.85938	21.828
7/8	0.87500	22.225
57/64	0.89062	22.622
29/32	0.90625	23.019
59/64	0.92188	23.416
15/16	0.93750	23.813
61/64	0.95312	24.209
31/32	0.96875	24.606
63/64	0.98438	25.003
1	1.00000	25.400

## English and Metric Equivalents

This section is based upon information published on the World Wide Web by the U.S. government's National Institute of Standards and Technology (NIST). For further information, visit their web site at [www.nist.gov](http://www.nist.gov).

Units of Length (Underlined Figures are Exact)						
Units	Inches	Feet	Yards	Millimeters	Centimeters	Meters
1 inch =	<u>1</u>	0.083 333	0.027 777	<u>25.4</u>	<u>2.54</u>	<u>0.025 4</u>
1 foot =	<u>12</u>	<u>1</u>	0.333 333	<u>304.8</u>	<u>30.48</u>	<u>0.304 8</u>
1 yard =	<u>36</u>	<u>3</u>	<u>1</u>	<u>914.4</u>	<u>91.44</u>	<u>0.914 4</u>
1 mile =	<u>63,360</u>	<u>5,280</u>	<u>1,760</u>	<u>1,609,344</u>	<u>160,934.4</u>	<u>1,609.344</u>
1 mm =	0.0393 700	0.003 280 8	0.001 093 6	<u>1</u>	<u>1</u>	<u>.001</u>
1 cm =	0.393 700 8	0.032 808	0.010 936	<u>10</u>	<u>1</u>	<u>0.01</u>
1 meter =	39.370 08	3.280 840	1.093 613	<u>1000</u>	<u>100</u>	<u>1</u>

Units of Area (Underlined Figures are Exact)					
Units	Square Inches	Square Feet	Square Yards	Square Centimeters	Square Meters
1 square inch =	<u>1</u>	0.006944	0.000 771 604 9	<u>6.451 6</u>	<u>0.000 645 16</u>
1 square foot =	<u>144</u>	<u>1</u>	0.111111	<u>929.030 4</u>	<u>0.092 903 04</u>
1 square yard =	<u>1296</u>	<u>9</u>	<u>1</u>	<u>8,361.273 6</u>	<u>0.836 127 36</u>
1 square mile =	<u>4,014,489,600</u>	<u>27,878,400</u>	<u>3,097,600</u>	<u>25,899,881,103.36</u>	<u>2,589,988.110 336</u>
1 square centimeter =	0.155 000 3	0.001 076 391	0.0001195990	<u>1</u>	<u>0.0001</u>
1 square meter =	1,550.003	10.763 91	1.195 990	<u>10,000</u>	<u>1</u>

Units of Volume (Underlined Figures are Exact)			
Units	Cubic Inches	Cubic Feet	Cubic Yards
1 cubic inch =	<u>1</u>	0.000 578 703 7	0.000 021 433 47
1 cubic foot =	<u>1,728</u>	<u>1</u>	0.037 037 04
1 cubic yard =	<u>46,656</u>	<u>27</u>	<u>1</u>
1 cubic centimeter =	0.061 023 74	0.000 035 314 67	0.000 001 307 951
1 cubic decimeter =	61.023 74	0.035 314 67	0.001 307 951
1 cubic meter	61,023.74	35.314 67	1.307 951

Units of Volume (Underlined Figures are Exact)			
Units	Milliliters (Cubic Centimeters)	Liters (Cubic Decimeters)	Cubic Meters
1 cubic Inch =	<u>16.387 064</u>	<u>0.016 387 064</u>	<u>0.000 016 387 064</u>
1 cubic foot =	<u>28,316.846 592</u>	<u>28.316 846 592</u>	<u>0.028 316 846 592</u>
1 cubic yard =	<u>764,554.857 984</u>	<u>764.554 857 984</u>	<u>0.764 554 857 984</u>
1 cubic centimeter =	<u>1</u>	<u>0.001</u>	<u>0.000 001</u>
1 cubic decimeter =	<u>1,000</u>	<u>1</u>	<u>0.001</u>
1 cubic meter =	<u>1,000,000</u>	<u>1,000</u>	<u>1</u>

## **B.1 Installing Motion Developer**

### **B.1.1 Computer System Requirements**

The following describes the minimum requirements to install and run Motion Developer software. (Catalog Number BC646MODEV)

#### **Hardware**

- 200 MHz Pentium-based workstation
- 64 MB RAM
- 200 MB free hard disk space
- CD ROM drive or access to one via parallel port or network
- 800 by 600 resolution, 256 color display and video adapter

#### **Software**

- Windows ® NT operating system version 4.0 with service pack 4 or later
- Windows 98, Windows ME, Windows 2000 & Windows XP operating system

### **B.1.2 Installation**

#### **To Install Motion Developer from a CD:**

1. Shut down all other application programs.
2. Insert the CD into your CD-ROM drive. Windows will automatically start the setup program. If the setup program does not automatically start, use the Windows Start/Run utility. Run the **setup.exe** file in the root directory of the CD.
3. Click Install CIMPPLICITY Machine Edition to start the install process.
4. Follow the instructions as they appear on the screen.

## B.2 Product Authorization

Before you can use Motion Developer, you must authorize the software with a program called Product Authorization. If you don't authorize the software, you will only be able to use it for a four-day trial period. This procedure will only take a few moments and will allow you to take advantage of any product support for which you qualify. You will need to contact us by telephone, fax, or email as part of the authorization process.

### B.2.1 To Authorize Motion Developer:

Have your serial number(s) ready. The serial numbers can be found on the License Key sheet that came with your product.

1. Run the Product Authorization utility from the Start menu/Programs/CIMPLICITY Machine Edition/Product Authorization. The Product Authorization dialog box appears.
2. Click Software, and then click Add.
3. You can authorize the software by means of the Internet, email, phone, fax, or disk (disk is used if transferring authorization from another computer). Make your selection, then click Next.
4. Under Mandatory, fill in the fields. If you are authorizing by fax, fill in the fields under Optional. Click Next.
5. You will be prompted for a key code. You can request your key code through the following means:
  - Phone.** Our phone number is listed on the screen.
  - Fax.** Click Print FAX and fax the Product Authorization Request to us (our fax number will be on the print out). We will then fax you back with your new key code(s).
  - Internet.** Go to [www.gefanuc.com](http://www.gefanuc.com), select the Support link, then choose the Software Registration link on the Support page.

Product Authorization is complete once you type in the new key code and it has been accepted. Depending on the product you've purchased, you may need to run the Product Authorization program a number of times.

### B.2.2 To Move the Authorization to Another Computer

You can only run the software on the computer on which the Product Authorization was installed. If you want to develop your projects on a different computer, you will need to complete the following steps to move the authorization from one computer to another.

1. Install CIMPLICITY Motion Developer on the computer to which the authorization will be moved.
2. Run the Product Authorization program from the Start menu/Programs/CIMPLICITY Machine Edition/Product Authorization. The Product Authorization dialog box appears.
3. Click Software. There is a site code on the top right hand side of the screen. Write down this site code carefully. This has to be accurate in order for the move to work. You will need it (Target Site Code) when you move the authorized software from the source computer.
4. Click Add. The Product Authorization wizard appears.

- 
5. Click Authorize by disk. At this point, you need to go to the source computer that has the authorized software, and move the authorization to a disk.
  6. From the source computer, run the Product Authorization program and click Software.
  7. Click Move, and then click OK. Enter the target site code that you wrote down from Step 3 and click Next. Verify that the site code is correct and click OK.
  8. Insert a blank formatted floppy disk into the floppy drive and click Next. The authorization code will be moved to the disk and a dialog box should appear telling you it was successful. Click OK.
  9. Go back to the computer to which you are moving the authorization and insert the floppy disk. (The screen that is asking for an authorization disk should be displayed.) Click Next.
  10. Click Finish. A screen should appear telling you the move was successful. Click OK. The authorization has now been moved to the new computer.

## B.3 Technical Support for Motion Developer Software

Support is available to registered Motion Developer users at no charge for one year. The SAFE Gold renewal (SA646MODEV) can be purchased from your local GE Fanuc distributor after the first year. If problems arise that can't be solved using the information in this guide or the online Help system, contact us by telephone, fax, or mail.

### Contact Choices

You have several contact choices if you need help with your GE Fanuc products:

- **Fax.** Send a message via the Technical Support Fax number at (780) 420 - 2049
- **Internet.** Use the address [www.gefanuc.com](http://www.gefanuc.com) to reach the GE Fanuc home page, then click the Support link to reach the main Support page. The Support pages allow you to look up technical information, download useful files, register software, or send a question to our support experts.
- **Telephone.** Call 1-800 GEFANUC (1-800 433-2682)
- **e-mail.** Address your message to [support@gefanuc.com](mailto:support@gefanuc.com)

### For Most Efficient Service

**Motion Developer Software Help.** When contacting us about a Motion Developer software problem, include the information listed below in your fax or message. If telephoning, call from a telephone near your computer and have your Motion Developer software running, if practical, and have the following information available to help us assist you as quickly as possible:

- The GE Fanuc software product name, serial number, and version number.
- The brand and model of computer system hardware (computer, monitor, etc).
- Computer operating system and version number.
- The steps you performed prior to the problem occurrence.

**S2K Motor and Controller Help.** When contacting us about an S2K hardware problem, include the information listed below in your fax or message. If telephoning, call from a telephone near your installation, if practical, and have the following information available to help us assist you as quickly as possible:

- The S2K model and serial number for controller and motor
- The circumstances leading up to the problem occurrence.

# Appendix C

## Interfacing With GE Fanuc APM or DSM Series Motion Controllers

### C.1 Wiring the S2K Amplifier to the APM300 Motion Controller

The APM300 series motion controller modules for the Series90-30 PLC are available in a 1-axis (IC693APU301) or 2-axis (IC693APU302) model. Connections are made through a 24-pin, male high-density connectors for each axis. The pin-out for the amplifier connections for each axis of the 2-axis model are the same. In order to connect the SSD104, SSD107 or SSD407 model S2K amplifiers to the APM module, an intermediate terminal block (part number 44A726268-001) is used. A 3-meter cable (IC693CBL311) connects the terminal block to the APM module as shown in Figure C-1 below.

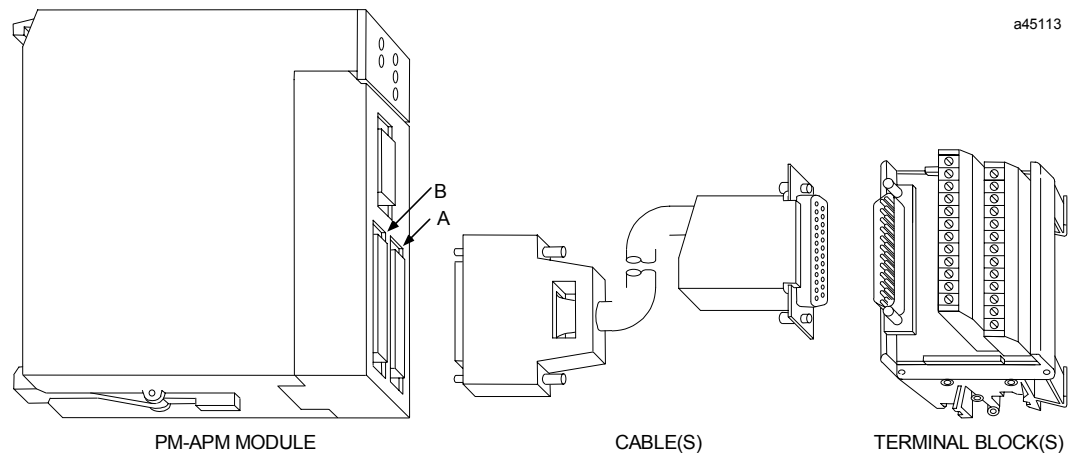

**Figure C-1. APM300 Terminal Block and Cable Connections**

Connections between the terminal block and the SSD104, SSD107 or SSD407 model S2K amplifier are made using a flying lead cable that plugs into the 25-pin D-shell Auxiliary on the amplifier. For the SSD216, SSD228 or SSD420 model amplifiers the Auxiliary I/O connections are available on screw terminals. Although GE Fanuc does not offer a prefabricated cable to directly make these connections a connector kit for the APM faceplate connectors (IC693ACC316) is available so that you can make your own cable. As an alternative, the optional terminal block assembly described above can also be used for the larger S2K amplifiers but you still need to

supply the wiring between the S2K Auxiliary I/O connector and terminal block screw terminals. Figure C-2 below shows the typical wiring between the APM terminal block and the S2K amplifier. For complete wiring details for the APM modules please refer to the APM User's Manuals, publication GFK-0781 for follower mode, or GFK-0840 for standard mode.

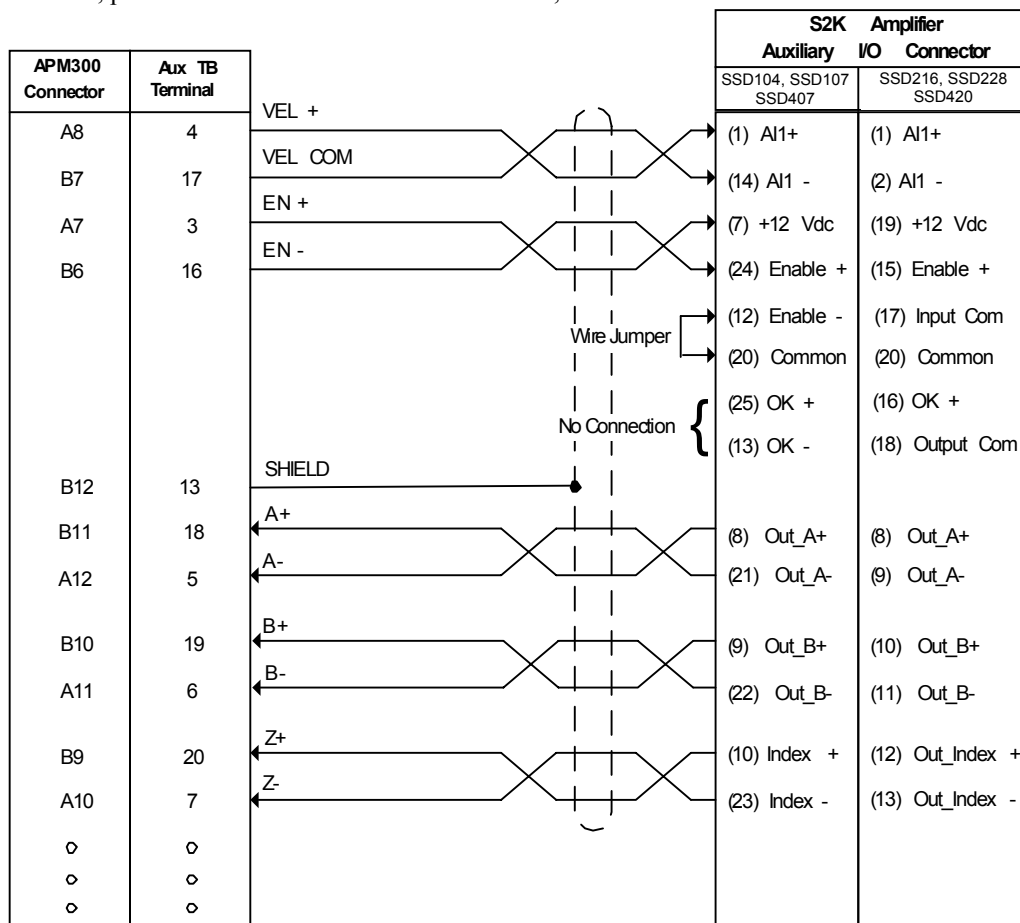
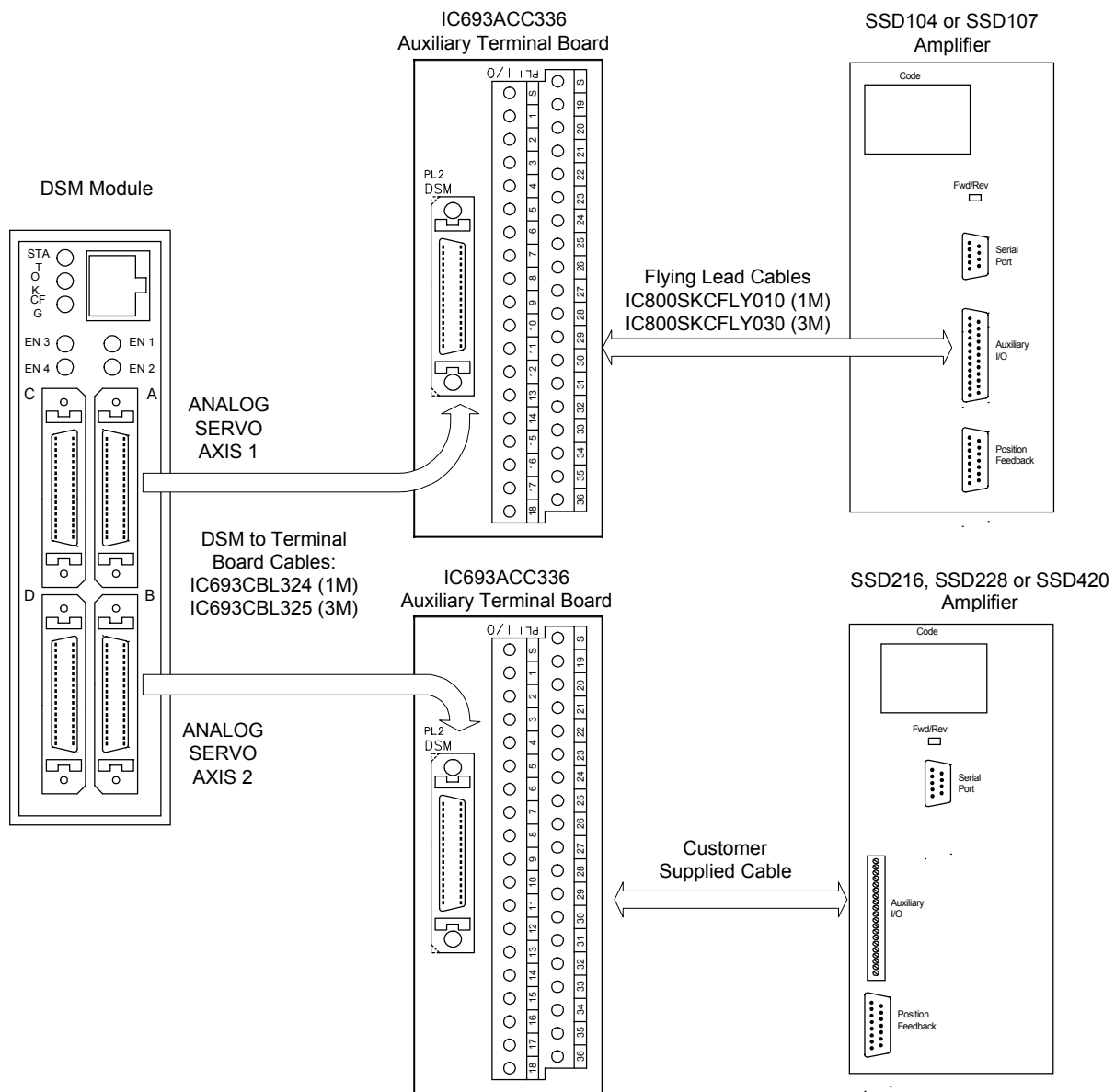

Figure C-2. APM300 to S2K Amplifier Connections Using Terminal Block 44A726268-001

## C.2 Wiring the S2K Amplifier to a DSM Motion Controller

The GE Fanuc IC693DSM302 motion controller module for the Series90™ -30 PLC can be configured to control one or two analog servos axes using a standard ± 10 Vdc command interface. The IC693DSM314 module can control up to four analog servo axes. When using the S2K amplifier with one of the DSM modules, an intermediate terminal board is required to facilitate the connections. The Auxiliary Terminal Board (part number IC693ACC336) can be either panel or DIN-rail mounted (see Section C.2.2 for conversion instructions) and includes screw terminals for connecting the S2K amplifier and any field wiring to the DSM. See the DSM302 User's Manual, GFK-1464, or DSM314 manual, GFK-1742, for more details on wiring the controller.

The figure below illustrates the Auxiliary Terminal board and cables associated with the DSM300 interface. Only two axes are shown for clarity.



Note: The DSM314 supports axis-3 and axis-4 connections on the C and D faceplate connectors using an identical wiring interface

**Figure C-3. DSM Terminal Boards and Cables for S2K Amplifier Interface**

## C.2.1 Auxiliary Terminal Board Description and Mounting Dimensions

The IC693ACC336 Auxiliary Terminal Board used to connect the DSM contains one 36 pin connector, labeled **DSM**. A cable, IC693CBL324 (1 meter) or IC693CBL325 (3 meters), connects the **DSM** connector (PL2) to the DSM module faceplate.

Thirty-eight screw terminals are provided on the Auxiliary Terminal Board for connections to the S2K amplifier and user devices. These screw terminals have the same pin labels as the 36 pin DSM faceplate connector.

**Caution**

**The maximum voltage that should be applied to I/O terminals 16-18 and 34-36 is 30 VDC. The maximum voltage for any other input terminal is 5 VDC.**

**Six 130V MOVs are installed between selected I/O points and the shield (frame ground) for noise suppression. The I/O terminal points so connected are 16, 17, 18, 34, 35, and 36.**

**The I/O terminals support a wire gauge of 14-28 AWG. Maximum screw torque that may be applied is 5 inch-pounds.**

Two of the screw terminals are labeled **S** for **Shield**. A short earth ground wire should be connected from one of the **S** terminals directly to a panel earth ground. The cable shields for any shielded cables from user devices should connect to either of the **S** terminals.

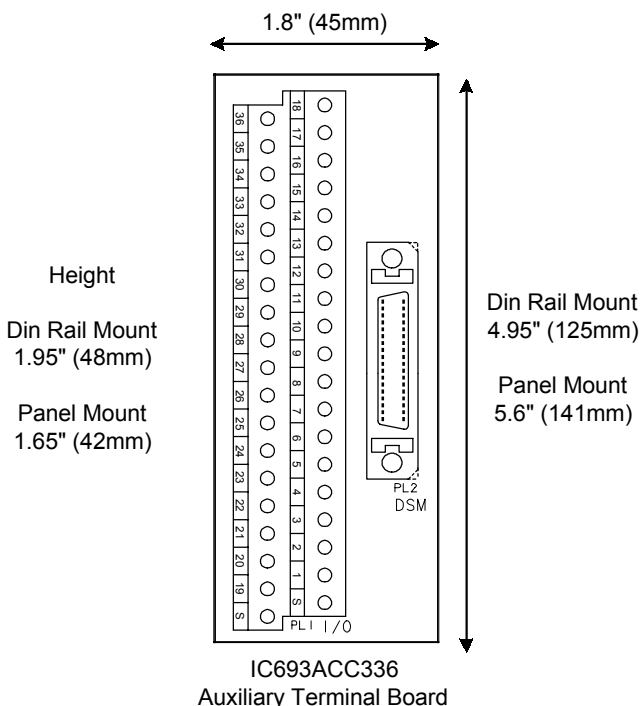

**Figure C-4. Auxiliary Terminal Board with Mounting Dimensions**

## C.2.2 Converting the Terminal Board From DIN-Rail to Panel Mounting

The following parts are used in either the DIN-rail or Panel mount assembly options. The auxiliary terminal board is shipped configured for DIN-rail mounting. The instructions in this section guide you in converting the board to its panel mounting optional configuration.

The following table and drawings describe the various plastic parts which make up the auxiliary terminal board assembly and show a side view of the board configured for DIN-rail mounting.

**Table C-1. Auxiliary Terminal Board Components**

Phoenix Contact Part Number	Description	Quantity
UM45 Profil 105.25	PCB Carrier	1
UM 45-SEFE with 2 screws	Side element with Foot	2
UMK 45-SES with 2 screws*	Side Element	2
UMK-BF*	Mounting Ear	2

\* Parts shipped with auxiliary terminal board for optional panel mounting.

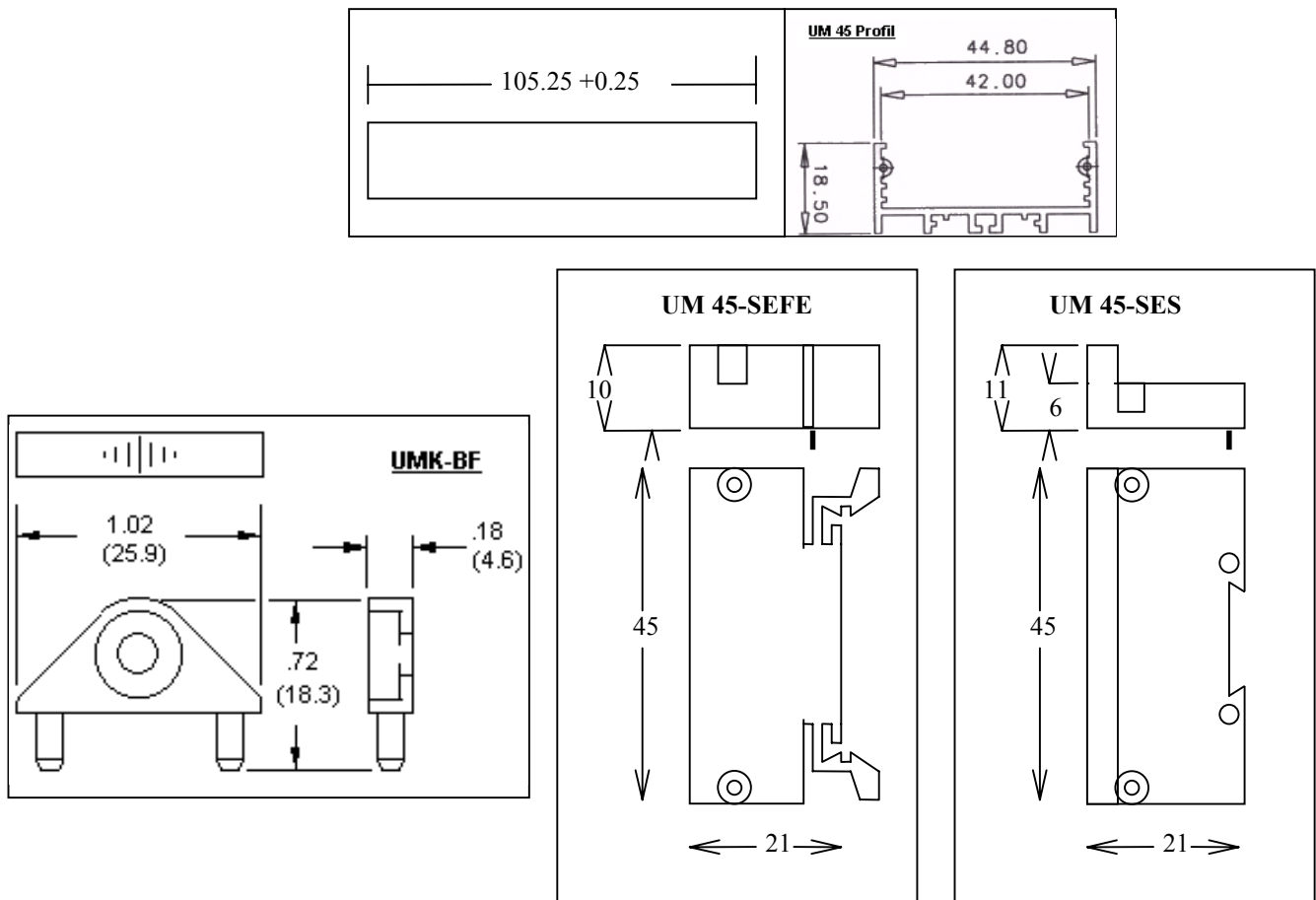

**Figure C-5. Auxiliary Terminal Board Assembly Drawings**

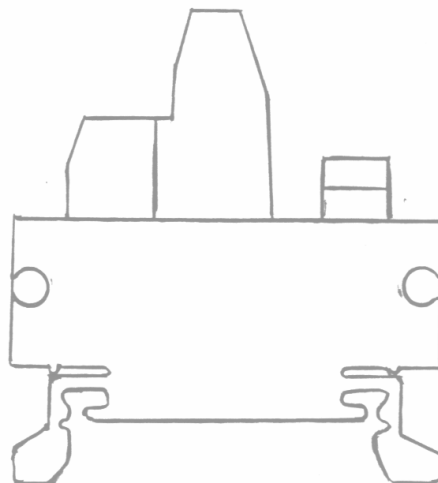

**Figure C-6. Auxiliary Terminal Board Assembly Side View**

The following procedure should be used to convert the auxiliary terminal board to its panel mounting form. Remember to save all removed parts for possible later conversion back to DIN-rail mounting.

1. Using a small bladed Phillips screwdriver, carefully remove the two screws holding one UM-45 SEFE side element with foot to the UM 45 Profil PCB carrier. Save this part for possible future use in converting the terminal board back to its DIN-rail mounting configuration.
2. Attach one UMK 45-SES side element to the PCB carrier in place of the side removed in step 1 above, again using the two screws. Be careful to not over tighten the screws.
3. Insert one UMK-BF mounting ear into the appropriate two holes in the side element. Note that the mounting ear has a recessed hole for later inserting a (user supplied) mounting screw. The recessed hole should face upwards to accommodate the mounting screw.
4. Repeat steps 1-3 above for the other side of the terminal board.

### C.2.3 Auxiliary Terminal Block Pin Assignments

Table C-2 identifies all circuits and pin assignments for the DSM Analog Servo Axes. The items in bold text are signals that specifically connect the DSM to the S2K amplifier. *The shaded areas indicate signals that are unused and not available for user connections.*

**Table C-2. Terminal Block Pin Assignments for DSM300 Analog Servo Axes**

Circuit Type	Circuit Function	DSM Analog Axis Signal Name	DSM Faceplate Connector Pin	Aux Term Board Terminal
Single Ended Or Differential 5V Inputs	Encoder Chan A (+)	IN1P_x	1	1
	Encoder Chan A (-)	IN1M_x	19	19
	Encoder Chan B (+)	IN2P_x	2	2
	Encoder Chan B (-)	IN2M_x	20	20
	Encoder Marker (+) Encoder Marker (-)	IN3P_x IN3M_x	3 21	3 21
5V Power	5v Encoder Power	P5V_x	4	4
0V	0V	0V_x	22,23	22,23
Single ended 5V input	Servo Ready Input	IN4_x	5	5
Single Ended 5V Inputs /Outputs	Strobe 1 Input	IO5_x	9	9
	Strobe 2 Input	IO6_x	10	10
	Not Used	IO7_x	11	11
	Not Used	IO8_x	12	12
0V	0v	0V_x	27-30	27-30
24v Optically Isolated Inputs	Overtravel (+)	IN9_x	16	16
	Overtravel (-)	IN10_x	34	34
	Home Switch	IN11_x	17	17
24v Input Common	24v Input Common	INCOM_x	35	35
24 v, 125 ma DC SSR Output	PLC 24v Output (+)	OUT1P_x	18	18
	PLC 24v Output (-)	OUT1M_x	36	36
Differential 5V Outputs	Not Used	OUT2P_x	13	13
	Not Used	OUT2M_x	31	31
	PLC 5v Output (+)	OUT3P_x	14	14
	PLC 5v Output (-)	OUT3M_x	32	32
24v, 30 ma SSR Output	Servo Enable (+)	ENBL1_x	15	15
	Servo Enable (-)	ENBL2_x	33	33
Differential +/- 10v Analog Inputs	PLC Analog In (+)	AIN1P_x	7	7
	PLC Analog In (-)	AIN1M_x	25	25
	PLC Analog In (+)	AIN2P_x	8	8
	PLC Analog In (-)	AIN2M_x	26	26
+/- 10v Analog Out	Servo Vel Cmd (+)	AOUT_x	6	6
Analog Out com	Servo Vel Cmd Com	ACOM_x	24	24
Cable Shield	Cable Shield	SHIELD_x		S

Figures C-7 and C-8 show typical connections between the DSM module and the S2K amplifier for each analog servo axis. Since the position feedback from the servo motor must be connected to the S2K amplifier to ensure proper commutation, the signals from the S2K amplifier encoder output are connected to the terminal board. This provides position feedback to close the loop so the DSM module can control the position of the motor.

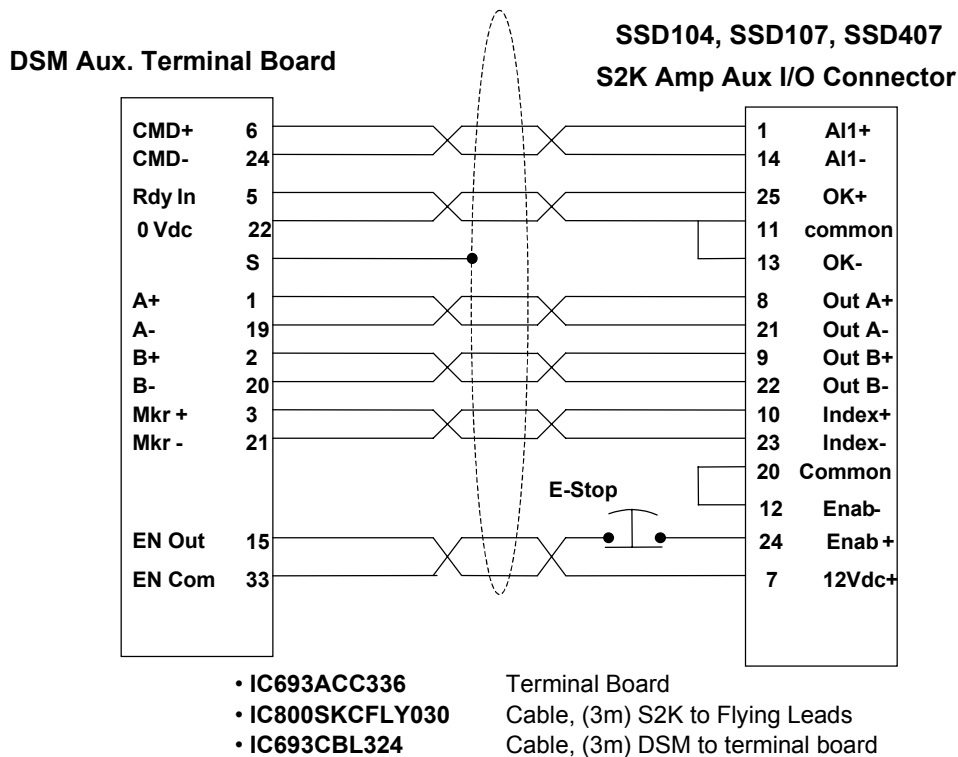

Figure C-7. DSM Analog Interface to SSD104, SSD107, and SSD407 Amplifier (With external Enable)

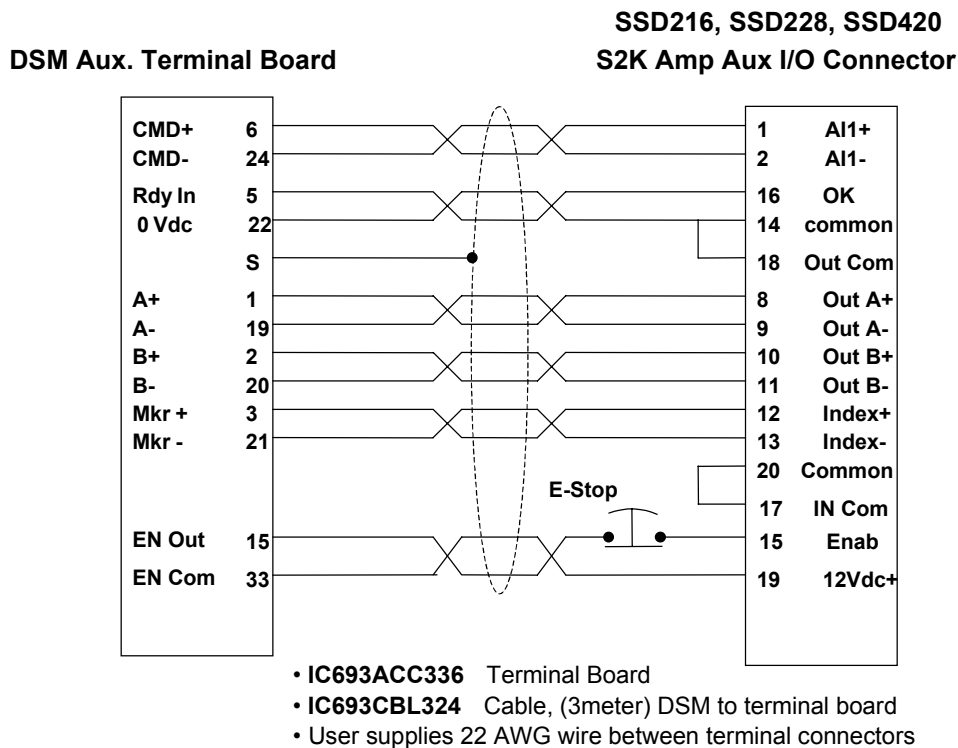

Figure C-8. DSM Analog Interface to SSD216, SSD228, and SSD420 Amplifier (With external Enable)

**?**

?, 5-3

**A**

AC Supply, 2-2  
 Agency approvals, 1-7  
 AI, 5-3  
 AIB, 5-4  
 AIO, 5-4  
 Altitude, 2-2, 3-2  
 Ambient temperature, 2-2, 3-1  
   motor derating, 2-15  
 Amplifier  
   Installation, 3-2  
 Analog input  
   command input description, 3-33, 4-14, 4-15  
   deadband adjustment, 5-4  
   offset, 5-4  
   scaling, 3-33, 4-14, 4-15  
   software register, 5-3  
   specifications, 2-3  
   torque limit input description, 3-33  
 Analog output, 3-34, 5-5  
   specifications, 2-3  
 AO, 3-34, 5-5  
 APM300, connection to, C-1  
 ASCII codes, A-1  
 Atmosphere, 3-1  
 Authorization  
   Motion Developer, B-2  
 AUTOTUNE, 4-23, 5-6  
   CURC, 5-6  
   FR, 5-6  
   KD, 5-6  
   KI, 5-6  
   KP, 5-6  
   KT, 5-6  
 Auxiliary encoder  
   input type selection, 5-32  
   using single ended inputs, 3-35  
 Auxiliary Terminal Board  
   Assembly Drawings, C-5  
   description and mounting dimensions, C-4  
 Axis Status Register, 5-33

**B**

Baud rates, 2-3  
 Brake  
   cables, 3-45  
   power supply, 2-16, 3-47  
   wiring diagram, 3-47

**C**

Cables, 3-45  
   APM terminal block interface, C-1  
 CE agency approvals, 1-7  
 Clear user memory, 5-7  
 CLM, 5-7  
 CMD, 5-7  
 CMO, 5-8  
 CMR, 5-9  
 Command  
   input scaling, 3-33, 4-14, 4-15  
   step input, 5-34  
 Command input, 3-33, 4-14, 4-15  
 Command output, 5-7  
 Communications  
   establishing with amplifier, 4-1  
   serial, specifications, 2-3  
 Commutation angle offset, 5-8  
 Commutation poles ratio, 5-9  
 Compatibility  
   motor and amplifier combinations, 1-5  
 Computer requirements  
   for Motion Developer, B-1  
 Configuration parameters, 4-21  
 Connection diagrams  
   SSD104 model, 3-37  
   SSD216 & SSD228 models, 3-44  
   to APM motion controller, C-2  
   to DSM motion controller, C-7  
 Connections  
   motor brake, 3-26, 3-27  
   motor encoder, 3-25, 3-28  
   motor power, 3-26, 3-27  
   S2K amplifier to APM300, C-1  
   S2K amplifier to DSM300, C-2  
   serial port, 3-30  
 Connector mates, 3-45  
 Conversion table  
   English to Metric, A-4  
 CUL/CUR agency approvals, 1-7  
 CURC, 5-10  
 CURC, 4-21  
 CURP, 5-11  
 CURP, 4-21  
 Current  
   amplifier ratings, 2-2  
   continuous limit, 5-10  
   peak limit, 5-11

**D**

Deadband adjustment  
   analog input, 5-4  
 Derating  
   motor, due to ambient temperature, 2-15  
 Derivative control gain, 5-25

Diagnostics  
  axis status register, 5-33  
  fault code register, 5-14  
  fault input register, 5-16, 6-4  
  general I/O register, 5-24

Digital input  
  enable, 3-36  
  specifications, 2-3  
  wiring, 3-30

Digital output  
  OK signal, 3-36  
  specifications, 2-3  
  wiring, 3-30

DIR, 5-12

Direction of motor, 4-20, 5-12

Dither  
  eliminate using filter time constant, 5-29

DSM300, wiring to, C-2

DT fault code, 5-14

Dynamic brake function, 3-55

## E

EC fault code, 5-14

EI fault code, 5-14

Electrical specifications, 2-1

Enable  
  digital input, 3-36  
  reset faults using, 3-36, 4-20, 6-1  
  torque limit, 5-36

Encoder  
  auxiliary encoder input specifications, 2-4  
  auxiliary input type, 5-32  
  cables, 3-45  
  encoder output specifications, 2-4  
  motor encoder input specifications, 2-4  
  motor feedback specifications, 2-4

Encoder output, 3-35, 4-18  
  functional description, 4-18  
  marker pulse width, 4-19, 5-13  
  type assignment (EOT), 5-13

Environmental specifications, 3-1  
  amplifier, 2-2

EOT, 5-13  
  selecting encoder output, 4-18

Equivalent units  
  English and Metric, A-6  
  fraction, decimal, mm, A-5

## F

Fault code register, 5-14

Fault input register, 6-4

Faults  
  resetting, 3-36, 4-20, 6-1

FC, 5-14

FE, 5-15

FE fault code, 5-14

FEB, 5-15

Feedback  
  specifications, 2-4

Feedback resolution, 5-17

FI, 5-16, 6-4

Filter time constant, 5-29

Firmware  
  view revision number, 5-32

FL fault code, 5-14

Following error, 5-15

Following error bound, 5-15

FR, 5-17

Frequency  
  ac supply, 2-2  
  PWM output, 2-2

Fuses  
  branch circuit, 2-2  
  logic supply, 2-2

## G

Gain  
  manual adjustment, 4-24  
  setting parameters, 4-23

Gearing  
  bound, 5-17  
  enable register, 5-20  
  filter constant, 5-20  
  input source selection, 5-21  
  ratio used to scale analog command input, 3-33, 4-14, 4-15  
  ratio, numerator register, 5-18, 5-22

General IO register, 5-24

GRB, 3-34, 4-17, 5-17

GRD, 3-34, 4-17, 5-18

GRE, 3-33, 3-34, 4-14, 4-16, 4-17, 5-20

GRF, 5-20

GRI, 5-21

GRN, 3-34, 4-17, 5-22

Ground fault breaker, 3-3

## H

Hardware resources, 2-1

Humidity, 2-2, 3-2

Hyper Terminal  
  using to configure amplifier, 4-2

## I

Input current, 2-2

Installation  
  Amplifier, 3-2

Location, 3-2  
 Motion Developer, B-1  
 motor, 3-3  
 Integral control gain, 5-26  
 IO register, 5-24  
 Isolation transformer, 2-2

## K

KD, 4-24, 5-25  
 KI, 4-24, 5-26  
 KL, 4-21, 5-27  
 KP, 4-24, 5-28  
 KT, 5-29  
 KT, 4-24

## L

LE fault code, 5-14  
 Limits  
   continuous current, 5-10  
   continuous torque, 5-35  
   peak current, 5-11  
 Location, 3-2  
 Logic power supply, 2-2

## M

Marker pulse width  
   encoder output, 4-19  
 Memory  
   clear user, 5-7  
 Motion  
   using to configure the amplifier, 4-6  
 Motion Developer  
   authorization, B-2  
   computer requirements, B-1  
   creating a new project, 4-8  
   Installation, B-1  
   motion toolbar, 4-10  
   setting up screen, 4-7  
   technical support, B-4  
 Motion type, 5-31  
 Motor  
   brake overview, 2-16  
   brake wiring, 3-47  
   brakes, 2-16  
   cables, 3-45  
   derating due to ambient temperature, 2-15  
   direction setting, 4-20, 5-12  
   inductance register, 5-27  
   installation, 3-3  
   mounting, 2-17  
   performance curves, 2-12  
   sealing, 2-16  
 MOTORSET, 5-30

Mounting  
   Amplifier. *See* Installation, Amplifier  
   motor, 2-17. *See* Installation, motor  
 MT, 5-31  
 MT fault code, 5-14

## O

OC fault code, 5-14  
 Offset  
   add to analog input, 5-4  
 OK output, 3-36  
 Operating mode, 5-31  
   configuring, 4-13  
 Operating temperature, 2-2  
 Output  
   amplifier OK, 3-36  
   analog, 5-5  
 OV fault code, 5-14

## P

Parity, serial port, 2-3  
 Part numbers, 1-2  
   amplifier, 1-3  
   motor, 1-3  
   regenerative resistor kits, 1-4  
   terminal block assemblies, 1-4  
 Performance curves, 2-12  
   servo motors, 2-12  
 PF fault code, 5-14  
 Pin assignments  
   DSM300 auxiliary terminal block, C-6  
   IC800SKCS030 serial cable, 3-30  
 Position command  
   scaling the input, 4-17  
 Position mode  
   configuring, 4-13  
   operation, 4-16  
 Proportional control gain, 5-28

## Q

Q, 5-31  
 QTX, 3-34, 5-32  
 Query command, 5-3, 5-31  
 Query machine parameters  
   real-time values, 6-6

## R

Regenerative discharge  
   application example, 3-53  
   calculating power, 3-51  
   resistor sizing, 3-51

Regenerative resistor  
  part numbers, 1-4  
  selection, 3-48  
  wiring, 3-48

Register  
  query value of, 5-31

Reset  
  faults, 3-36, 4-20, 6-1

Resolver  
  specifications, 2-4

REVISION, 5-32

**S**

Scaling  
  position command input, 4-17  
  torque command input, 4-14  
  velocity command input, 4-16

Sealing, motor, 2-16

Serial communications  
  cable, 3-45, 4-1  
  establishing with amplifier, 4-1  
  specifications, 2-3

Serial number  
  Motion Developer, B-2

Servo motor  
  performance curves, 2-12

Shaft Seal, 2-16

Software  
  Hyper Terminal, 4-2  
  Motion Developer, 4-6  
  terminal emulation, 4-1

Specifications  
  amplifier power, 2-2  
  analog inputs, 2-3  
  analog outputs, 2-3  
  auxiliary encoder input, 2-4  
  digital inputs, 2-3  
  digital outputs, 2-3  
  electrical, 2-1  
  encoder output, 2-4  
  environmental, 3-1  
  environmental, amplifier, 2-2  
  motor encoder input, 2-4  
  motor resolver input, 2-4  
  serial communications, 2-3

Speed/torque curves  
  servo motors, 2-12

Speed/Torque curves, 2-12

SRA, 5-33

STEP, 5-34

Step input, 5-34

Storage, 1-2

System components, 1-5

System overview, 1-1

## T

Tables and formulas  
  appendix, A-1

Technical support  
  Motion Developer, B-4

Temperature conversion  
  formulas and table, A-3

Terminal block assemblies  
  part numbers, 1-4

Terminal board assemblies  
  components, C-5  
  converting from DIN rail to panel mounting, C-5  
  S2K to APM300, C-1  
  S2K to DSM300, C-4

Terminal window  
  emulation software, 4-1  
  Motion Developer toolbar button, 4-10

Tie terminal, 3-35

TLC, 5-35

TLE, 4-20, 5-36

Toolbars, Motion Developer  
  Motion, 4-10

Torque command  
  scaling the input, 4-14

Torque derating, 2-15

Torque limit  
  enable, 5-36  
  setting, 4-20, 5-35

Torque limit input, 3-33

Torque mode  
  configuring, 4-13  
  operation, 4-13

Transformer, 2-2

Troubleshooting flowchart, 6-7

Tuning, 4-23  
  autotune, 4-23, 5-6  
  derivative gain register, 5-25  
  filter time constant, 5-29  
  integral gain register, 5-26  
  manual gain adjustment, 4-24  
  motor inductance register, 5-27  
  proportional gain register, 5-28

## U

UL/UR agency approvals, 1-7

Unpacking, 1-2

## V

Velocity command  
  scaling the input, 4-16

Velocity mode  
  configuring, 4-13  
  operation, 4-15  
Ventilation, 3-2

## **W**

Wire size  
  English to Metric, A-2  
Wiring  
  AC supply, 3-22  
  analog output, 3-34  
  auxiliary encoder input, 3-34  
  auxiliary I/O, 3-30  
  command input (AI1), 3-33, 4-14  
  dynamic brake function, 3-55  
  enable input, 3-36  
  encoder output, 3-35, 4-18  
  grounding, 3-22  
  motor brake, 3-26, 3-27  
  motor encoder feedback, 3-25, 3-28  
  motor power, 3-22, 3-26, 3-27  
  OK output, 3-36  
  S2K amplifier to APM300, C-1  
  S2K amplifier to DSM300, C-2  
  serial port, 3-30  
  torque limit input (AI2), 3-33