

IC600BF842
New In Stock!
GE Fanuc

<http://www.pdfsupply.com/automation/ge-fanuc/ge-series-six-6/IC600BF842>

Ge Series Six 6
1-919-535-3180

In Stock! -10Vdc to +10Vdc Analog Input Module (8 channels)
IC600B IC600BF

www.pdfsupply.com

Email: sales@pdfsupply.com

GEK-83525E

81pc76

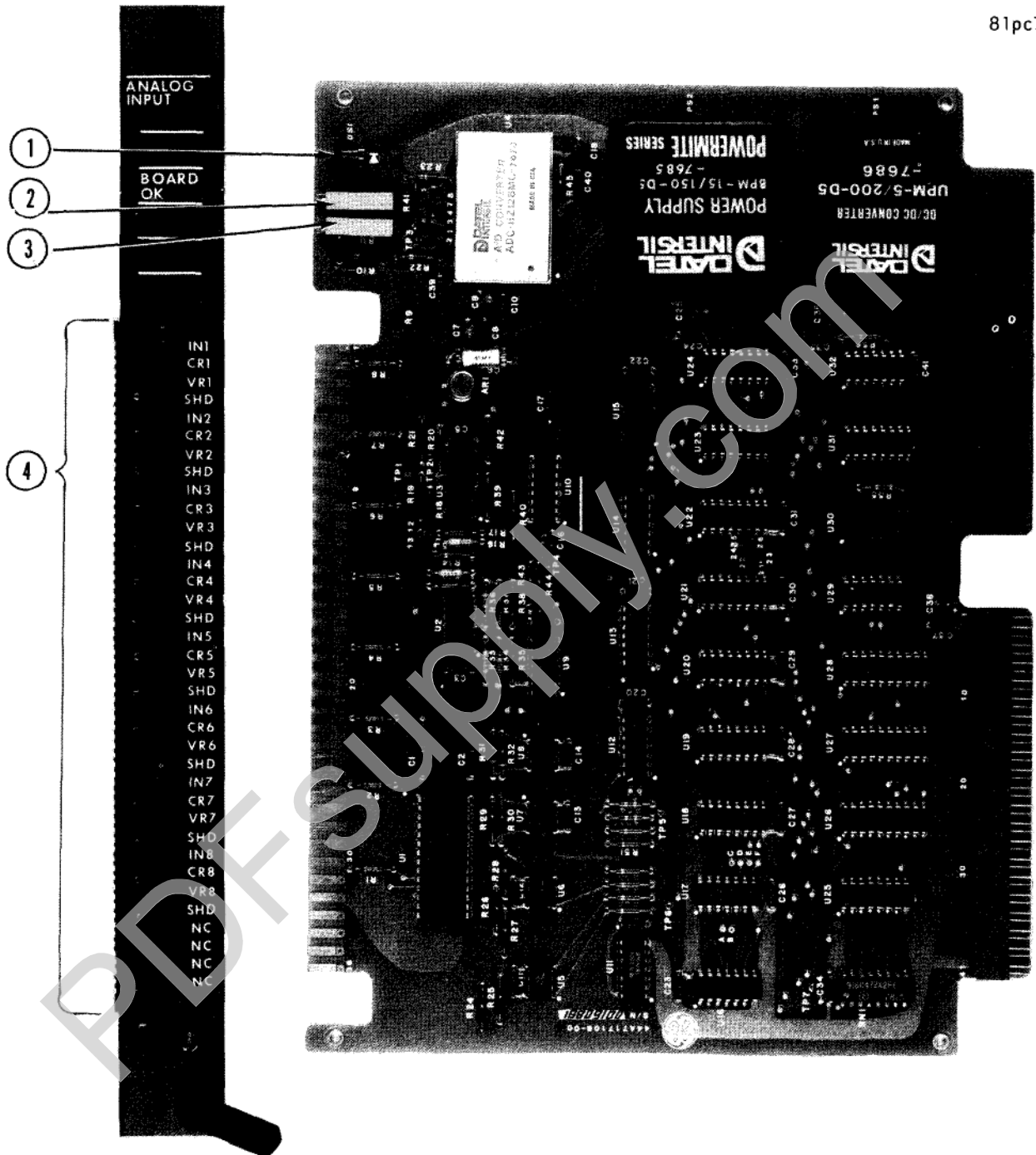

Figure 1. User Items

- | | |
|---|--|
| <p>1. BOARD OK Light:
The LED is OFF if there is an A/D converter malfunction, an I/O-rack power supply problem, or the CPU is in the Stop or the Run Disabled mode. It is also Off if the module has not been read since one of these conditions existed, or since power has been applied.</p> | <p>2. R12: Offset Potentiometer, (All Channels)
3. R11: Gain Potentiometer, (All Channels)
4. User Connector Block</p> |
|---|--|

Installation

The Analog Input module can be installed in an I/O rack, a Model 60 CPU rack, or a Series Six Plus CPU rack. Before installing the Analog Input module, the dual-in-line-package (DIP) switches immediately behind the card slot on the rack backplane should be set to reserve a group of 32 consecutive bits in the appropriate Input Status Table of the CPU. For specific DIP switch settings, see below.

Use the extraction/insertion tool furnished with the CPU to remove or install the circuit board. With the board in place in the rack, the edge connector on the faceplate should be slipped over the circuit board so that proper contact is made, then secure the faceplate to the rack using the thumbscrews at the top and bottom. Both the Input terminal (IN) and the Return terminal of any unused input channels should be connected to the shield terminal.

Input Number	Dip Switch Position				
	7	6	5	4	3
1 - 32					
33 - 64					X
65 - 96				X	
97 - 128				X	X
129 - 160			X		
161 - 192			X		X
193 - 224			X	X	
225 - 256			X	X	X
257 - 288		X			
289 - 320		X			X
321 - 352		X		X	

Input Number	Dip Switch Position				
	7	6	5	4	3
353 - 384		X		X	X
395 - 416		X	X		
417 - 448		X	X		X
449 - 480		X	X	X	
481 - 512		X	X	X	X
513 - 544	X				
545 - 576	X				X
577 - 608	X			X	
609 - 640	X			X	X
641 - 672	X		X		
673 - 704	X		X		X

Input Number	Dip Switch Position				
	7	6	5	4	3
705 - 736	X		X	X	
737 - 768	X		X	X	X
769 - 800	X	X			
801 - 832	X	X			X
833 - 864	X	X		X	
865 - 896	X	X		X	X
897 - 928	X	X	X		
929 - 960	X	X	X		X
961 - 992	X	X	X	X	
993 - 1024	X	X	X	X	X

(NOT USED)

X = Switch in OPEN Position (Depressed to the Left)

Switches No. 1 and 2 should be in CLOSED Position

Notes

A group of 32 consecutive I/O points are required to be selected for this module to communicate to and from the Input Table. Each of the eight input channels will utilize these same 32 I/O points. Each time a total I/O scan is executed, one of the input channels of this module will be scanned, converted, and sent to the Input Table. The next time a total I/O scan is executed the channel number is incremented by one and the next channel is scanned, converted, and sent to the Input Table on the same 32 consecutive I/O points. This process is repeated each time a total I/O scan is executed until all of the input channels are converted and sent to the Input Table. At this time the process repeats, one per total I/O scan, until all the

channels are scanned. It is the responsibility of the user to program a store in a register of these data bits during the solution cycle and use the registers for reference inputs as the Input Table will reflect only one input channel at a time and the register will contain all eight channels.

Using the CPU extended functions, the user can elect to read repeatedly the same channel or scan up to all eight channels in sequence at a much faster rate than the normal I/O scan rate. This is accomplished by programming a "DO I/O" function during the normal user program. Refer to the Application Guide Manual, GEK-25365, for more detailed instructions.

GEK-83525E

Electrical Installation

The Analog Input modules can be driven and wired to in many ways. A symbolic Analog Input module circuit is shown in Figure 2. For typical user input connections when using a 0 to 10V or -10 to +10V analog signal transmitter refer to Figure 3.

When using a +1 to +5V, 4 to 20 ma, or 10 to 50 ma analog signal transmitter refer to Figure 4 for typical user input connections. For other types of analog transmitters such as Type 2, Type 3, or Type 4, refer to Instrument Society of America Standard, ISA-S50.1, for guidance. A Type 2 transmitter is shown for reference only in Figure 5.

70tmp21

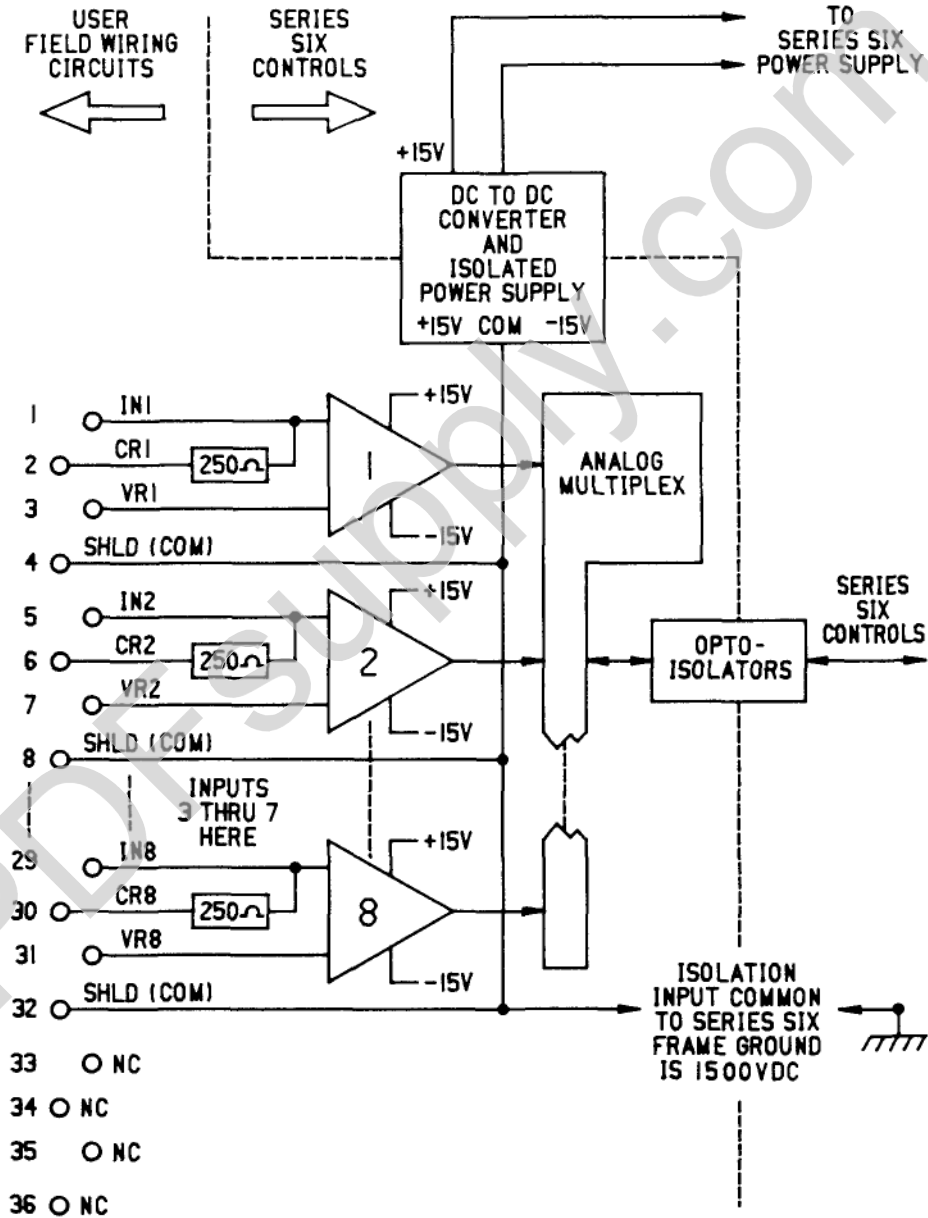

Figure 2. Symbolic Analog Input Module Circuit

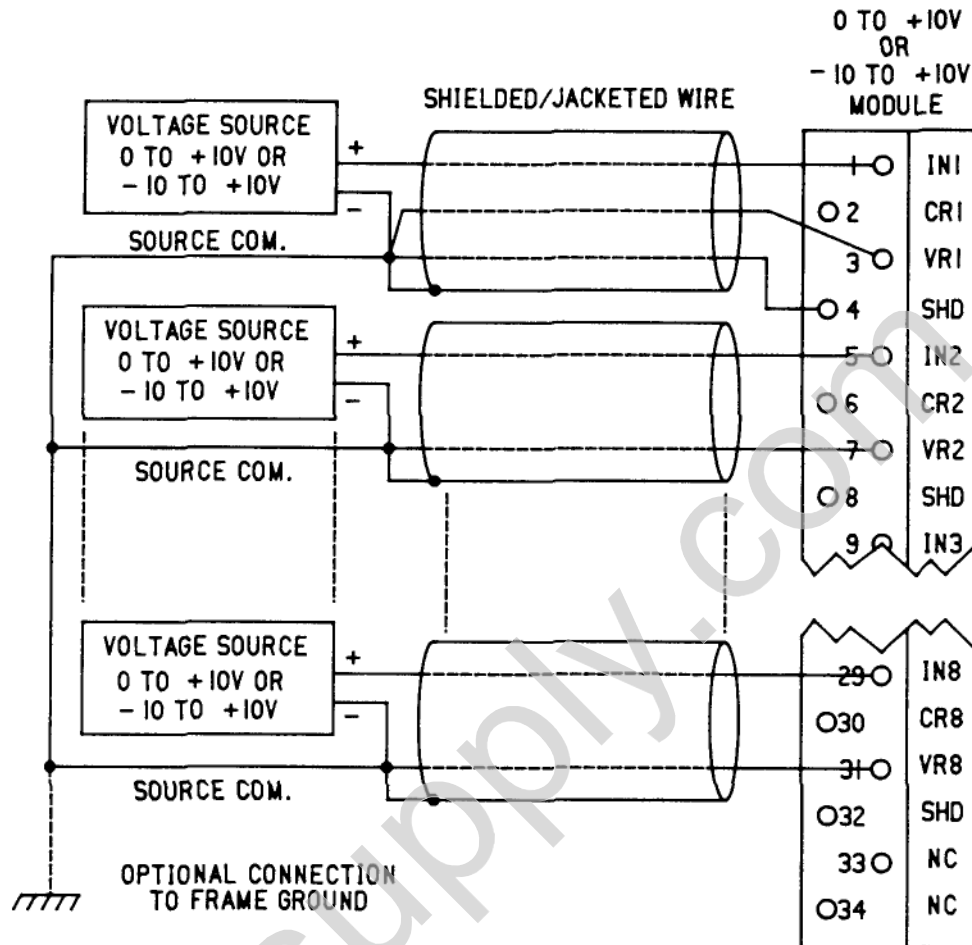

Figure 3. Typical User Input Connections (0 to +10 V or -10 to +10 V)

CAUTION

The signal lines (such as wires that connect to an IN- or VR- terminal) must be no more than $\pm 11V$ from the common (SHD) terminal at any time or damage may result to the module.

Notes

For an unbalanced source, the ground shield should be connected to the source common or ground as shown in the connection for input 2 above. If all of the source inputs to this module come from the same location and are referenced to the same common, a connection is made as shown in Input 1 to the SHD/common input to the module.

If the inputs to any one analog input module come from multiple sources, care must be taken to connect each of the source common points together and then

connect to the Analog Input module at only one terminal, such as Terminal 4 above. This will eliminate multiple grounding or ground loops which can cause false input data.

All terminals marked SHD/common are internally connected together with 1500 V DC isolation to chassis. An optional way to connect the shields is to connect only one end and connect all shields at the module. Source commons should all be connected together and connected back to the module at only one place such as Input 1 above.

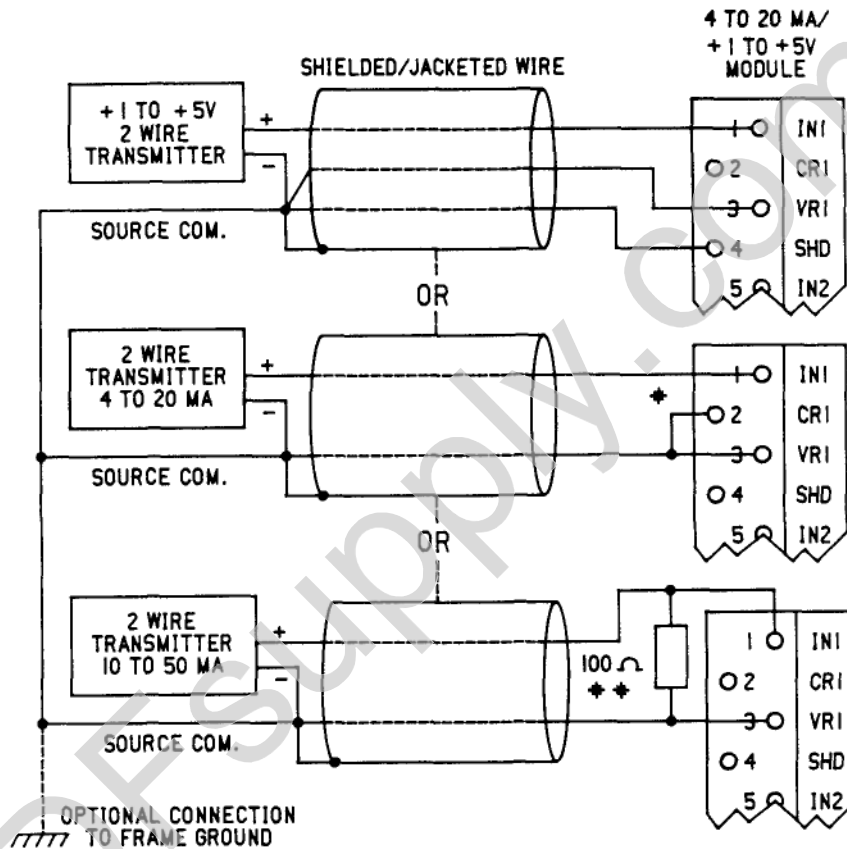

Figure 4. Typical User Input Connections (4 to 20 mA)

Notes

Reference the notes shown pertaining to Figure 3. These same notes apply to Figure 4, plus the following:

- * 250 Ω shunt resistor provided internally (by GE Fanuc - NA) for 4 to 20 ma input use only.

** User may connect a 100 Ω shunt resistor if input is 10 to 50 ma.

Reference Figure 5 for a typical Type 2 current transmitter wiring hookup.

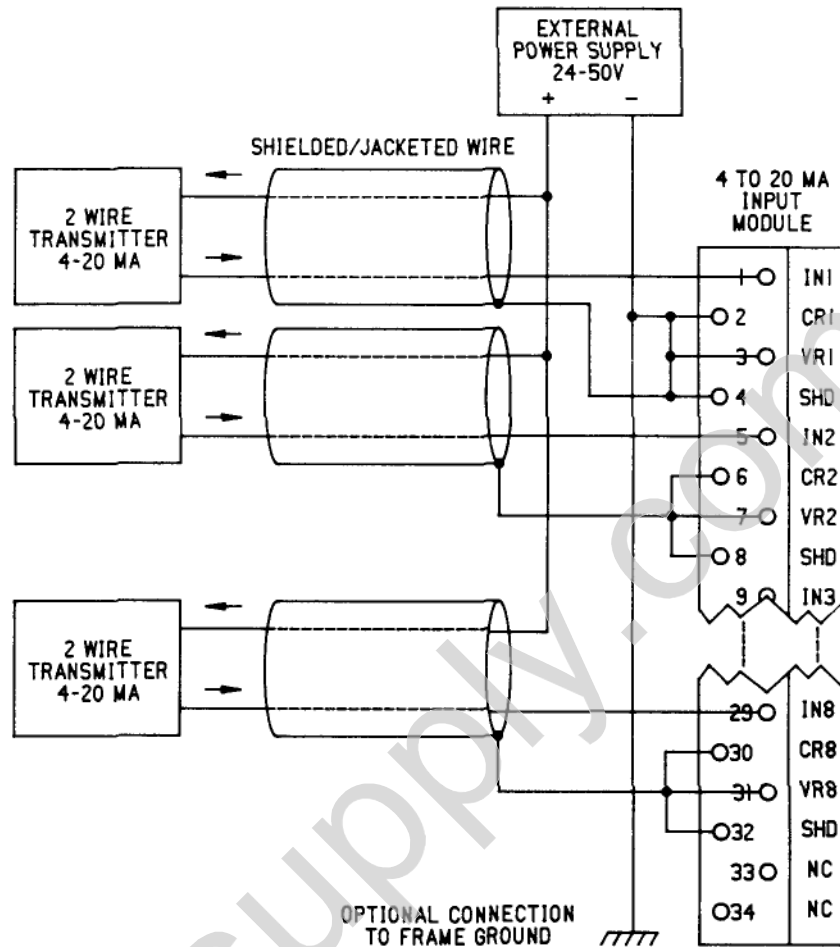

Figure 5. Typical Wiring for Type 2 Transmitters Requiring an External Power Supply (4 to 20 mA)

Notes

This configuration represents only one of many possible wiring hookups to the 4 to 20 ma input module and is shown for reference only. Using the symbolic Analog Input module circuit Figure 2, this Figure (5), and the Instrument Society of America Standard

ISA-S50.1 publication most wiring hookups will be readily apparent.

The signal lines (such as inputs to IN-, CR-, or VR-terminals) must be no more than 11 volts from the common (SHD) terminal at any time or damage may result to the module.

Digital Data Format

Bit 1 corresponds to the lowest input number in the group of 32 inputs reserved for the module; Bit 32 corresponds to the highest input number in this group.

Bits 1-8: Channel Number: 8-bit binary number giving the number of the channel (1 to 8) being read. It consists of three significant bits (bits 1-3) and five zeroes (bits 4-8).

Bits 9-16: Status Byte:

Bit 13: Board OK: High if both +5 V and +15 V power-supply levels are OK; LOW otherwise.

Bit 14: Underrange: HIGH if input level is at or below the low end of the module range; LOW otherwise.

Calibration Procedure

Required equipment:

Voltmeter - 5 digit
 (Voltage Source - Resolution to 0.1 MV)
 Calibration Connector (IC600MA508A)

Calibration of the Analog Input module should be performed every 90 days. For maximum accuracy the board should be calibrated at the normal ambient temperature which occurs in operation.

1. SET UP: Loosen the thumbscrews and remove the faceplate, taking care not to disturb the field wiring. Take the calibration connector, voltage source, and the voltmeter wired as shown in Figure 6 and connect it to the module in place of the faceplate. Program the CPU to move the converted digital data from this channel to a convenient register location, where its value can be observed using the Program Development Terminal (PDT). This can be done by using the following program:

```

      IWWWW      IXXXX      IYYYY      IZZZZ      RAAAA
+ - - / - - + - - / - - + - - / - - + I/O      TO REG +      ( )
  
```

where:

IWWWW: Lowest of the 32 consecutive input numbers used by this Analog Input module.

IXXXX: Next input number: XXXX = WWWW + 1

IYYYY: Next input number: YYYYY = WWWW + 2

IZZZZ: Input number corresponding to the LSB of digital input data: ZZZZ = WWWW + 16.

RAAAA: Register to display digital input data.

2. LOW END: Set the voltage source as close as possible to the value shown in Table 3. Adjust R12 (Refer to Figure 1) until the digital output agrees with the value in Table 3. There will be a slight delay for the register output value to update to reflect an adjustment as eight (8) I/O total scans may be required to read and convert the data for channel 1.
3. HIGH END: Set the voltage source as close as possible to the value in Table 3. Adjust R11 (Refer to Figure 1) until the digital output matches the value in Table 3.
4. FINE ADJUSTMENT: Repeat steps No. 2 and No. 3 until the module is in calibration at both ends of its range simultaneously.

Table 4. Module Calibration

MODULE	LOW END		HIGH END	
	Source Voltage	Digital Output*	Source Voltage	Digital Output*
0 to +10 V	+0.0024 V	00001	+9.9951 V	OFFE
+1 to + 5 V (4 to 20 mA)	+1.0010 V	00001	+4.9980 V	OFFE
-10 to +10 V	-9.9951 V	F801	+9.9902 V	07FE

*In Hexadecimal Format

Module Reconfiguration

The Analog Input module can be reconfigured to function in any of three input ranges: 0 to +10V, -10

to +10V or 4 to 20 mA (1 to +5V). The user should note that all eight input channels, on any given module, provide a common input range.

INPUT RANGE	JUMPER POSITIONS
0 to +10v (unipolar)	1-2, 7-10, 8-9, 6-11, 13-14, 21-22, 24-25
-10V to +10V (bipolar)	1-3, 4-7, 8-9, 6-11, 13-14, 22-23, 25-26
4 to 20 mA (+1V to 5V)	1-2, 3-4, 5-6, 7-8, 12-13, 21-22, 24-25

Table 5. Ordering Information

Module	Circuit Board & Faceplate	Faceplate
0 to +10 v	IC600BF841	IC600FP841
-10 to +10 v	IC600BF842	IC600FP841
4 to 20 mA (+1 to +5 V)	IC600BF843	IC600FP843

Calibration Connector IC600MM08

The UL symbol on the nameplate means the product is listed by Underwriters Laboratories Inc. (UL Standard No. 508, Industrial Control Equipment, subsection Electronic Power Conversion Equipment.)

For further information, contact your local GE Fanuc sales office.

NOTE

The Analog Input module will function properly only when used with Series Six Plus CPUs and Models 60, 600 and 6000 CPUs with the following serial numbers:

Model 60 CPU: C188 -8135 -0130, and higher.

Model 600 CPU: C188 -8138 -0100, and higher.

Model 6000 CPU: C188 -8138 -6000, and higher.

If your CPU has a serial number lower than that listed, contact the PLC Product Service Specialist at (804)978 -5624 for assistance.