

IC600BF904
New In Stock!
GE Fanuc

<http://www.pdfsupply.com/automation/ge-fanuc/ge-series-six-6/IC600BF904>

Ge Series Six 6
1-919-535-3180

In Stock! 115Vac Output Module (8 points) IC600B IC600BF

www.pdfsupply.com

Email: sales@pdfsupply.com

- ① Terminal Cover
- ② User Terminal Block:
Accepts connections from user output devices and the AC power source(s). See the "Installation" section of this Data Sheet.
- ③ Circuit-Board Terminal Block:
Mates with the user terminal block.
- ④ Output Lights: 1 through 8
Off: Corresponding output is in the ON state.
Off: Corresponding output is in the OFF state.
- ⑤ BF (Blown Fuse) Lights
On: The fuse for corresponding output is open (blown).
Off: The fuse for corresponding output is OK.
- ⑥ Output-Circuit Fuses (3 A normal blow).

FIGURE 2. USER ITEMS (Part 2 of 2)

INSTALLATION

The AC Output modules can be installed in an I/O rack or the I/O rack section of the Model 60 Central Processor Unit (CPU). Follow these steps:

1. Set the Dual-In-Line Package (DIP) switches directly behind the card slot on the rack backplane to establish the correct correspondence between the input terminals on this module and a group of eight consecutive input numbers in the user program. For further information on I/O DIP switch settings, refer to the Installation section of the Series Six Installation and Maintenance Manual (GEK-25361).
2. Use the extraction/insertion tool furnished with the Series Six CPU to insert (or remove) this module in the card slot.
3. Guide the faceplate over the circuit board so that the terminals near the bottom of each are mated; secure the faceplate to the rack using the thumb-screws at the top and bottom.
4. Refer to Figure 3. Connect one side of the user circuit to the appropriate input terminal (1 through 8). Circuits connected to inputs 1 through 4 must have their opposite sides connected to either of the N1 terminals. Likewise, circuit connected to inputs 5 through 8 must have their opposite sides connected to either of the N2 terminals.

In reference to Figure 3, note that wires connected to the N1 terminals are at the same potential, as are wires connected to the N2 terminals.

Each input terminal can accommodate one No. 12 AWG wire or two No. 14 AWG wires.

5. Guide the terminal cover onto the top of the terminal block, then slide it downward over the terminals.

A markable area is provided on the plastic lens beside each Light-Emitting Diode (LED) for noting the function or source of each input. The faceplates are color coded:

Yellow:	115 Vac
Red:	230 Vac

WARNING

Voltages from user field devices may be present on the faceplate terminals, even if the power supply in the I/O rack is off. Care should be taken when handling the faceplate of this module or any wires connected to it.

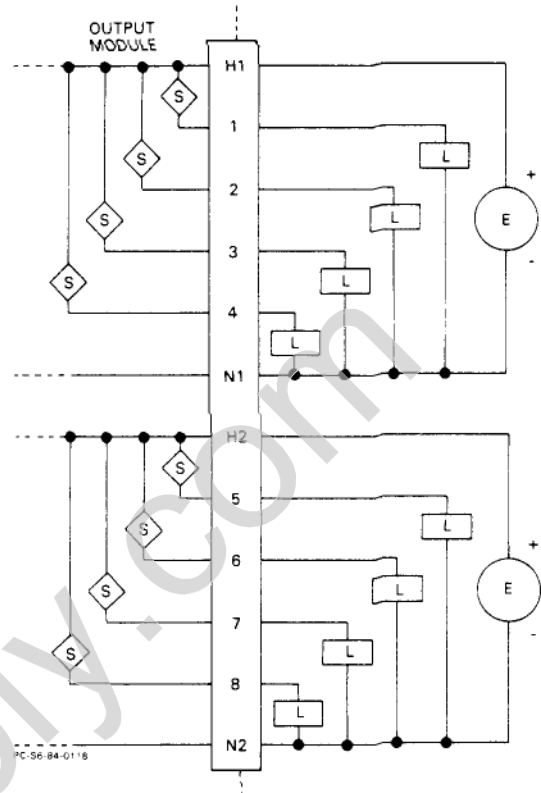

FIGURE 3. TYPICAL USER OUTPUT CONNECTIONS

ORDERING INFORMATION

Module	Circuit Board and Faceplate	Circuit Board	Faceplate
115 Vac	IC600BF904B	IC600YB904B	IC600FP904B
230 Vac	IC600BF905B	IC600YB905B	IC600FP905B

CATALOG NUMBER REVISION SUFFIX

The equipment listed above having the catalog numbers shown and the same equipment having a higher alpha suffix is designed for listing by UL for use as auxiliary control devices. The equipment is a direct replacement for equipment having the same catalog number but a lower alpha suffix.



This symbol on the nameplate means the product is listed by Underwriters Laboratories Inc. (UL Standard No. 508, Industrial Control Equipment, subsection Electronic Power Conversion Equipment.)

For further information, contact your local GE Fanuc sales office.

GE Fanuc Automation North America, Inc., Charlottesville, Virginia