

IC600BF943
New In Stock!
GE Fanuc

<http://www.pdfsupply.com/automation/ge-fanuc/ge-series-six-6/IC600BF943>

Ge Series Six 6
1-919-535-3180

In Stock! 4-20mA Analog Output Module (4 channels) IC600B
IC600BF

www.pdfsupply.com

Email: sales@pdfsupply.com

- Dimensions:

Circuit Board: 8.15 x 11.0 x 1.20 (inches)
208 x 280 x 31 (mm)

Faceplate: 12.46 x 1.175 (inches)
317 x 30 (mm)

- Operating Temperature: 0° to 60°C (at the outside of the rack)
- Storage Temperature: -20° to +80°C
- Humidity: 5% - 95% (non-condensing)
- Noise (Current Loop): < 1 uA rms, DC to 10 kHz
- Total Output Drift @ 0 Volts Out: < 10 ppm of Full Scale per °C, Typical
< 30 ppm of Full Scale per °C, Maximum
- Total Output Drift @ Full Scale: < 20 ppm* of Full Scale per °C, Typical
* ppm = parts per million
Example: 10 ppm = 10 ÷ 1 million = .001%.
- Power Requirements: 5V DC, 1.5 A, Supplied by I/O-rack power supply.
- Optional Power Requirements: User supplied (4 to 20 mA modules only)
+23V to +42.4V regulated.
The current requirements and power supply must be adequate for the devices being driven by the Output module. Reference: ISA specification ISA-S50.1.
- Output Current (voltage range modules): ± 5 mA
- All outputs will sustain continuous short circuit.
- Output Load Capacitance: 750 pF maximum
- Cross Talk: Offset of channel change from plus Full Scale to minus (-) Full Scale is < 0.005%
- Accuracy: Resolution 12 Binary Bits (1 part in 4096)
Linearity ± 0.012% of Full Scale

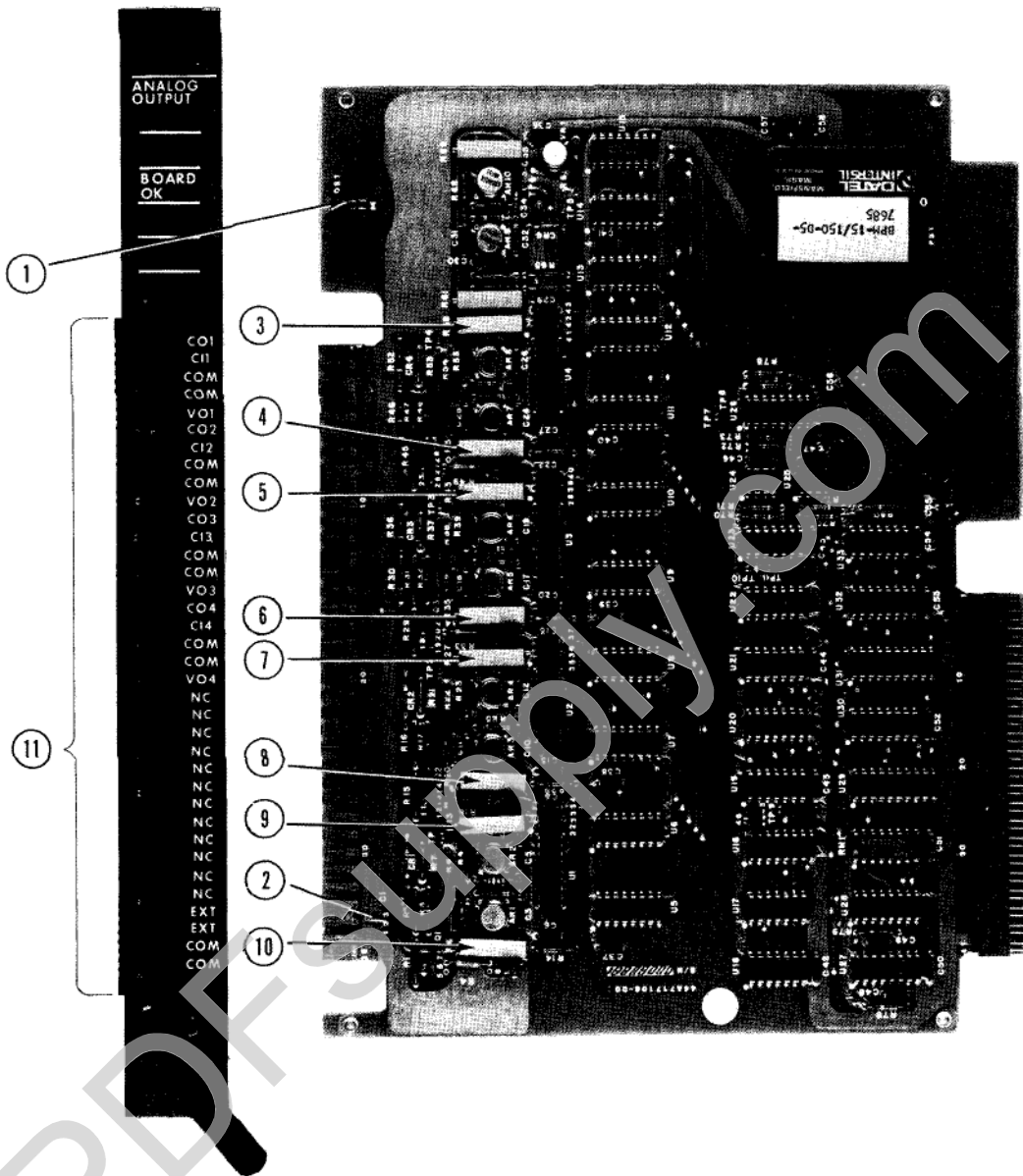

- ① BOARD OK Light:
The LED is OFF if there is a board malfunction, an I/O-rack power supply problem, or the CPU is in the Stop or the Run Disabled mode. It is also Off if the module has not been accessed since one of these conditions existed, or since power has been applied.
- ② Jumper to Select Internal Loop Supply/Common External Source.
- ③ R59: Gain Potentiometer, Channel No. 1
- ④ R51: Offset Potentiometer, Channel No. 1

- ⑤ R43: Gain Potentiometer, Channel No. 2
- ⑥ R35: Offset Potentiometer, Channel No. 2
- ⑦ R27: Gain Potentiometer, Channel No. 3
- ⑧ R20: Offset Potentiometer, Channel No. 3
- ⑨ R13: Gain Potentiometer, Channel No. 4
- ⑩ R6: Offset Potentiometer, Channel No. 4
- ⑪ User Connector Block

FIGURE 2. USER ITEMS

INSTALLATION

The Analog Output modules can be installed in an I/O rack or in a Model 60 CPU rack. Before installing the Analog Output module, the dual-in-line-package (DIP) switches immediately behind the card slot on the rack backplane should be set to reserve a group of 16 consecutive bits in the appropriate Output Status Table of the CPU. For specific DIP switch settings, refer to Figure 3.

Use the extraction/insertion tool furnished with the CPU to remove or install the circuit board. With the board in place in the rack, the edge connector on the faceplate should be slipped over the circuit board so that proper contact is made. Then, secure the faceplate to the rack using the thumbscrews at the top and bottom.

OUTPUT NUMBER	DIP SWITCH POSITION					OUTPUT NUMBER	DIP SWITCH POSITION					OUTPUT NUMBER	DIP SWITCH POSITION					
	7	6	5	4	3		2	7	6	5	4		3	2	7	6	5	4
1- 16							353-368	X	X	X	X		705-720	X	X	X	X	
17- 32					X		369-385	X	X	X	X	X	721-736	X	X	X	X	X
33- 48				X			385-400	X	X				737-752	X	X	X	X	
49- 64				X	X		401-416	X	X		X		753-768	X	X	X	X	X
65- 80			X				417-432	X	X	X			769-784	X	X			
81- 96		X	X				433-448	X	X	X	X		785-800	X	X			X
97-112		X	X				449-464	X	X	X			801-816	X	X			X
113-128			X	X	X		465-480	X	X	X	X		817-832	X	X		X	X
129-144		X					481-496	X	X	X	X		833-848	X	X	X		
145-160		X		X			497-512	X	X	X	X	X	849-864	X	X	X	X	
161-176		X	X				513-528	X					865-880	X	X	X	X	
177-192		X	X	X			529-544	X			X		881-896	X	X	X	X	X
193-208		X	X				545-560	X		X			897-912	X	X	X		
209-224		X	X	X			561-576	X	X	X			913-928	X	X	X		X
225-240		X	X	X			577-592	X		X			929-944	X	X	X	X	
241-256		X	X	X	X		593-608	X	X	X	X		945-960	X	X	X	X	X
257-272		X					609-624	X		X	X		961-976	X	X	X	X	
273-288		X		X			625-640	X		X	X	X	977-992	X	X	X	X	X
289-304		X	X				641-656	X	X				993-1008	X	X	X	X	X
305-320		X	X	X			657-672	X	X		X		1009-1024	X	X	X	X	X
321-336		X	X	X	X		673-688	X	X	X			(NOT USED)					
337-352		X	X	X	X		689-704	X	X	X	X							

X = Switch in OPEN Position (Depressed to the Left)
 Switches No. 1 and No. 2 should be in CLOSED Position

FIGURE 3. DIP SWITCH SETTINGS

NOTES

1. A group of 16 consecutive I/O points are required for this module to communicate with the Output Status Table. Each of the four output channels in this module uses these same 16 I/O points for the loading of data. Each of the output channels has its own memory contained within the module. All channels being used will have a constant output whether it is updated every scan or every 10 scans. Each time a total I/O scan is executed the output programmed by the user logic program will be updated. Refer to the Programming Manual, GEK-25362, for more detailed instructions.
2. Using the CPU Extended Functions, the user can elect to output repeatedly the same channel or

scan up to all four channels in sequence at a much faster rate than the normal I/O scan rate or output up to all four channels in sequence at a much faster rate than the normal I/O scan rate. This is accomplished by programming a "DO I/O" function or functions during the normal user program. Refer to the Application Guide, GEK-25365, for more detailed instructions.

3. It is the responsibility of the user to program a store in a register of the data that has been or is going to be output to the various output channels. These registers will be the data used in the logic program as the output table will have data about only one of the output channels in it.

ELECTRICAL INSTALLATION

The Analog Output modules can be used and wired to in many different ways. A symbolic Analog Output circuit is shown in Figure 4. Typical user output connections when using a 0 to +10V or -10V to +10V Analog Signal receiver refer to Figure 5.

For the 4 to 20 mA Analog Output module, the channels can be connected for internal or external common source operation depending on the setting of the circuit board jumper. Alternatively, any one or more individual channels can be connected with its own external source.

Be aware that all common (COMM) terminals are connected together inside the module. To minimize capacitive loading of the the outputs, twisted-pair cables should be used for output connections wherever possible.

Refer to Figure 6 for typical user output connections. For other types of Analog receivers refer to Instrument Society of America Standard ISA-S50.1 for guidance.

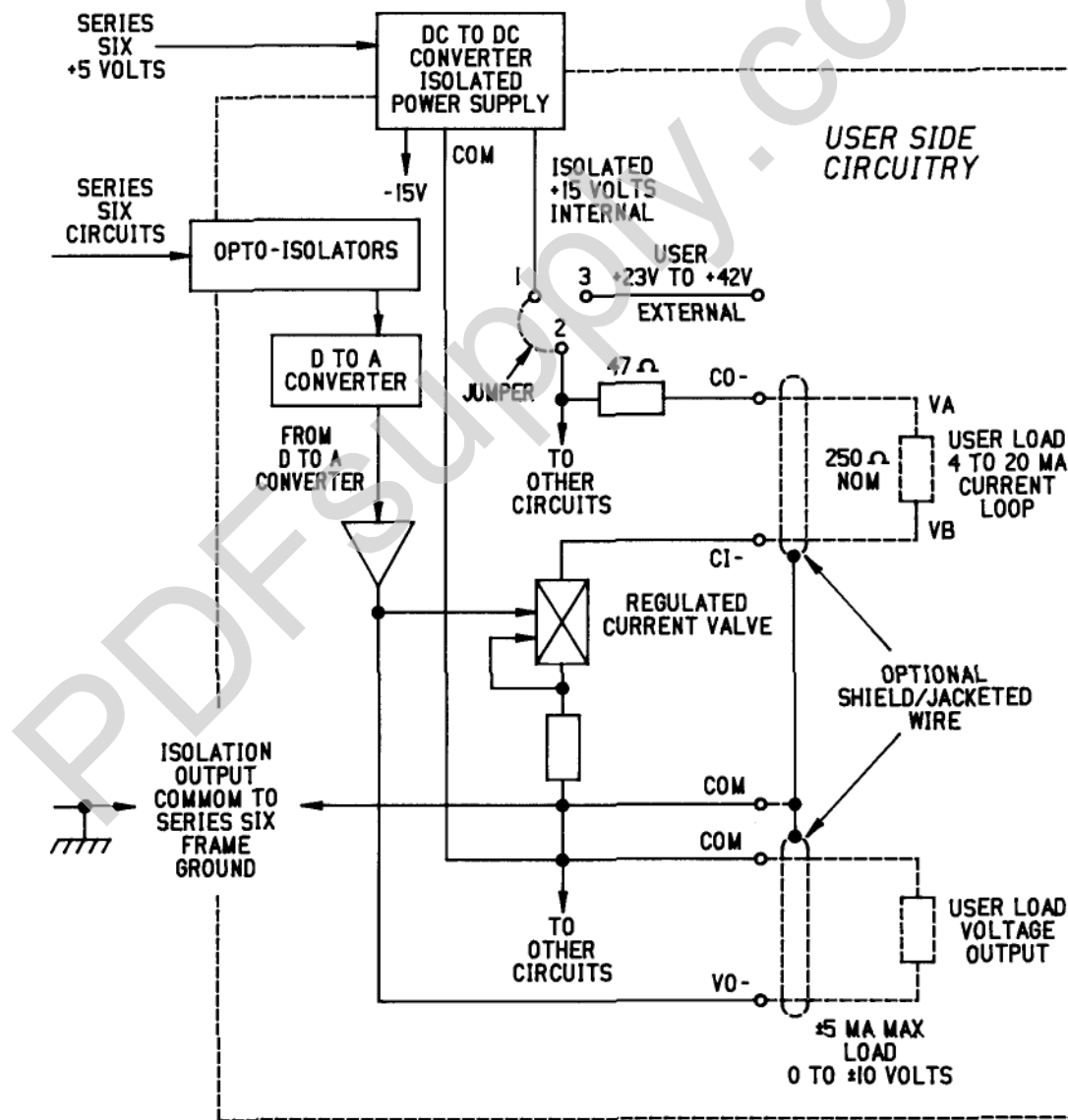

FIGURE 4. SYMBOLIC ANALOG OUTPUT MODULE CIRCUITRY

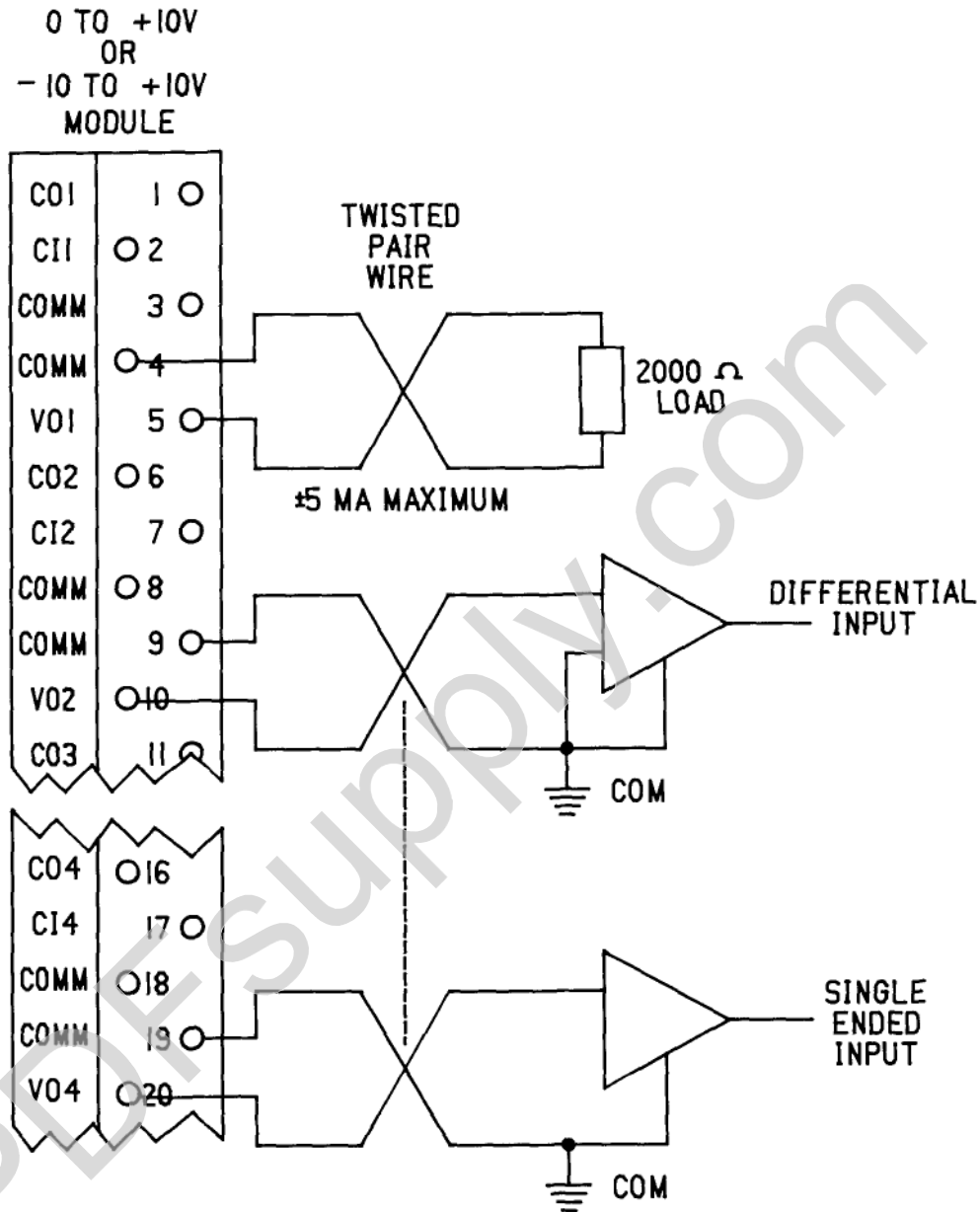

FIGURE 5. TYPICAL VOLTAGE OUTPUT CONNECTIONS

NOTES

1. Maximum Loading is ± 5 mA for full voltage output.
2. All four outputs on this module are single ended and must be referred to the same user side common which is isolated from Series Six ground.
3. All COMM terminals are connected together internally to the module.
4. If multiple destinations are connected to the same output module their reference points (common) must be connected together and be at the same voltage.
5. Twisted-pair cable should be used whenever possible. Twisted pair and shield is preferred.

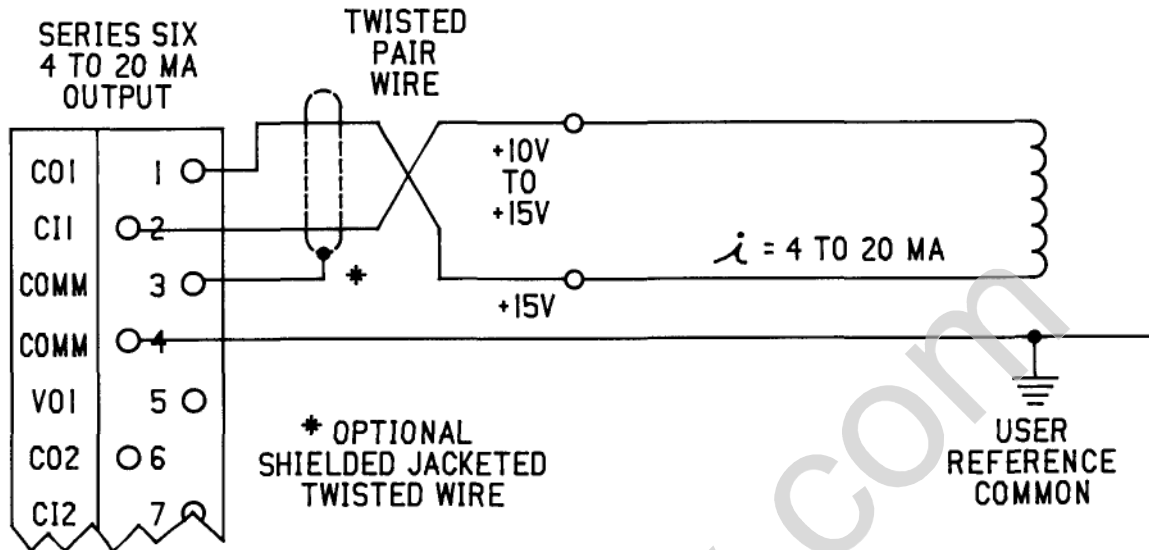

FIGURE 6A. SYMBOLIC FLOATING USER INPUT CIRCUIT
 SERIES SIX - 4 to 20 mA OUTPUT MODULE INTERNAL LOOP POWER SUPPLY

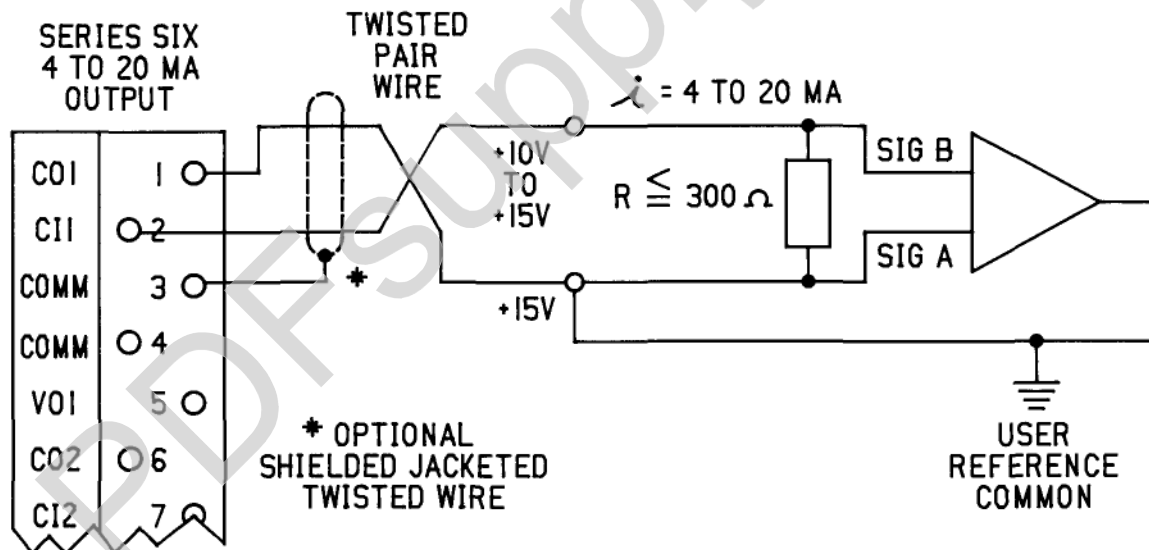

FIGURE 6B. SYMBOLIC NON-FLOATING USER INPUT CIRCUIT OR
 SERIES SIX ANALOG INPUT MODULE

NOTES

1. If damage can be caused to user input circuitry when Signal A or Signal B are more than 10V above user common then user common must be connected as shown in Figure 6B to the Series Six +15V point. Because of this connection user common should never be connected to Series Six common.
2. The loading of the 4 to 20 mA module should be in accordance with ISA-S50.1 Transmitter Standard Class 2L when the module is using the internal loop power supply as shown.

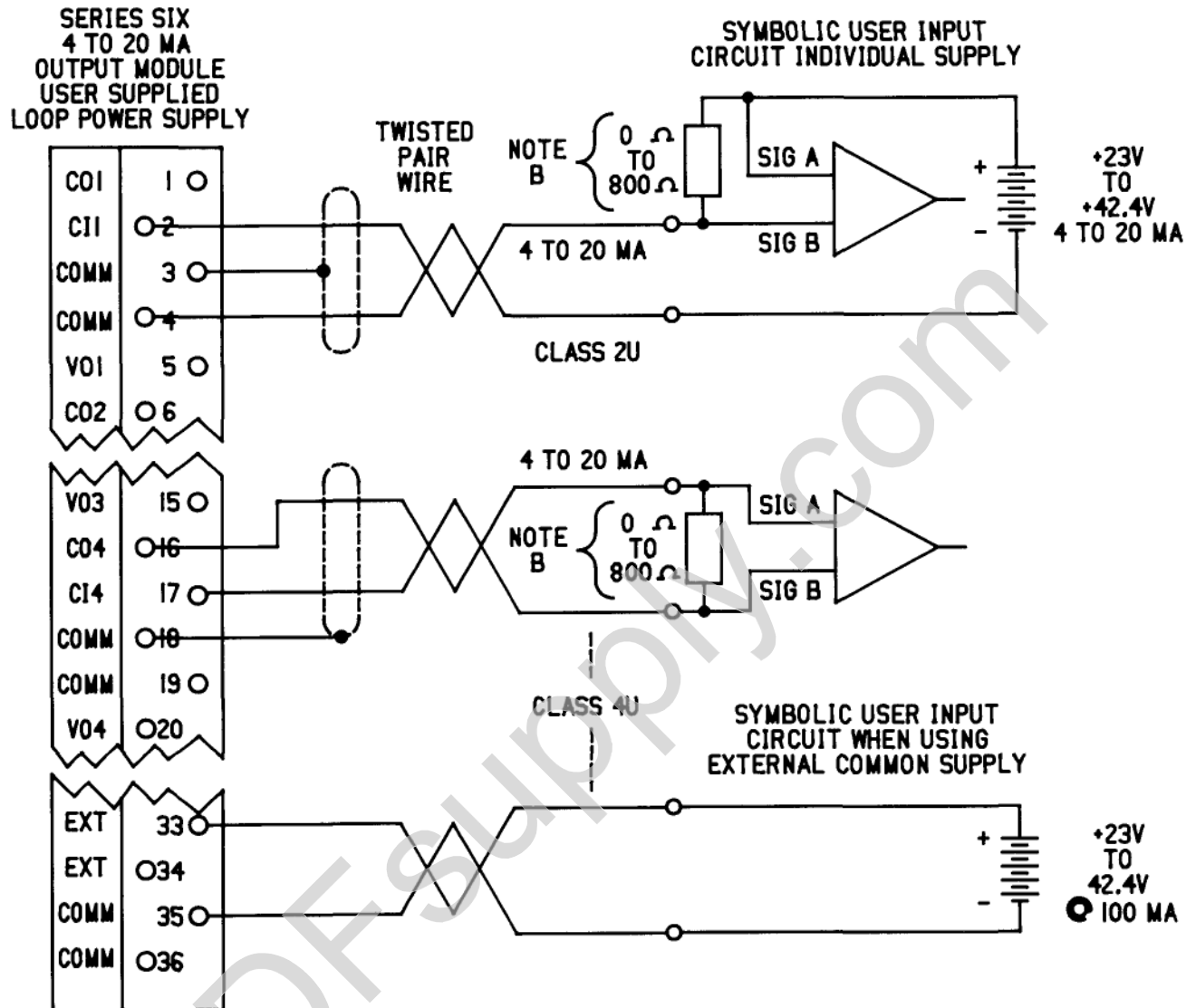

FIGURE 7. TYPICAL OUTPUT CONNECTIONS FOR 4 TO 20 mA OUTPUT USING EXTERNAL POWER SUPPLY

NOTES

4 TO 20 mA CURRENT OUTPUT TO FLOATING USER INPUTS ONLY

- A. If damage could be caused to user input circuits because Signal A and Signal B inputs are from +23V to 42V above common (depending on the external supply), then the user must select other truly floating input receivers that can withstand this voltage differential.
- B. The loading of the 4 to 20 mA module when using an external power supply should be in accordance with ISA-S50.1 Transmitter Class 2U or 4U data. This module is in compliance with or exceeds this specification.
- C. Individual external supplies or common external supplies may be used on the same output module if the commons of the two supplies are at the same potential and may be connected together.
- D. All points marked "COMM" on the output module are tied together internally. Caution must be used when connecting user commons to the same output module.

DIGITAL DATA FORMAT

Bit 1 corresponds to the lowest output number in the group of 16 outputs reserved for the module; Bit 16 corresponds to the highest output number in this group.

Bits 1-8: Data: Eight least significant of the twelve bits of data. Bit 1 is the least significant bit (LSB).

Bits 13-14: Channel Number: 2-bit binary number which determines the number of the channel (1 to 4) being accessed. Bit 14 is the MSB.

Bits 9-12: Data: Four most significant of the twelve bits of data. Bit 12 is the most significant bit. For the bipolar (-10 V to +10 V) module, Bit 12 functions as a sign bit.

Bits 15-16: Not used: (May be in either a HIGH or LOW state.)

The twelve bits of data should be in straight binary form for positive output values, or in 2's-complement form for negative values. For the Bipolar (-10 V to +10 V) module, bit no. 12 functions as a sign bit.

OUTPUT STATUS TABLE DISPLAY

Two consecutive I/O addresses are required to write all 16 bits of information associated with each channel. A single channel is normally accessed during each sweep. The channel number is determined by the CPU, under control of the user program.

CHANNEL NO.	CHANNEL NUMBER CODE		DATA													
	16	15	14	13	12	11	10	9	8	7	6	5	4	3	2	1
1	U	U	C	C	D	D	D	D	D	D	D	D	D	D	D	D
2	N	N	H	H	A	A	A	A	A	A	A	A	A	A	A	A
3	U	U	A	A	T	T	T	T	T	T	T	T	T	T	T	T
4	S	S	N	N	A	A	A	A	A	A	A	A	A	A	A	A
	E	E	N	N												
	D	D	E	E	B	B	B	B	B	B	B	B	B	B	B	B
			L	L	I	I	I	I	I	I	I	I	I	I	I	I
					T	T	T	T	T	T	T	T	T	T	T	T
1			0	0												
2			0	1	M											L
3			1	0	S											S
4			1	1	B											B
					*											

* For Bipolar bit No. 12 functions as Sign bit.

CALIBRATION PROCEDURE

Required equipment: Voltmeter - 5 digit
 250 ohm Precision Resistor
 Calibration Connector (IC600MA508A)
 Small screwdriver with approximately 3 inch insulated shaft.

Calibration of the Analog Output module should be performed every 90 days. For maximum accuracy the module should be calibrated at the normal ambient temperature which occurs in operation.

1. SET UP:

Loosen the thumbscrews, remove the faceplate, taking care that the field wiring is not disturbed. Place the calibration connector on the front edge of the module. For the 0 to + 10 V or the -10 V to + 10 V module connect a Digital Voltmeter (DVM) between the terminals of the calibration connector as listed in the "V" column for the first channel in Table 2. For the 4 to 20 mA module, connect a 250 ohm precision resistor in parallel with the DVM, using the terminal numbers in the "I" column of Table 2. Be sure that the circuit-module jumper is set for the internal loop supply.

Display the Output Status Table on the screen of the Program Development Terminal (PDT), with the cursor on the lowest output number assigned to this module by the DIP switches. Shift the display to hex format, obtaining a display of four hexadecimal digits corresponding to the 16 Output Status bits used by this module.

2. LOW END:

Using the PDT keyboard, enter the four hex digits shown in the LOW END column of the Calibration Table into the Output Status Table. Note that the first digit assigns the channel number (1 to 4). Adjust the Offset Pot (Refer to Figure 2) for this channel until the DVM reads the voltage shown in Table 3.

3. HIGH END:

Using the PDT keyboard, enter the four hex digits shown in the HIGH END column of Table 3 into the Output Status Table. Adjust the Gain Pot (Refer to Figure 2) for this channel until the DVM reads the voltage shown in Table 3 .

4. FINE ADJUST:

Repeat steps No.2 and No.3 until no further change in either pot setting is required.

5. OTHER CHANNELS:

Change the connections according to Table 2, and repeat steps No.2, No.3, and No.4 for channels 2, 3 and 4.

TABLE 2. CHANNEL ADJUSTMENT

	TERMINALS		CHANNEL NUMBER (*X)	OFFSET POT	GAIN POT
	V	I			
First Channel	5,4	1,2	1	R51	R59
Second Channel	10, 9	6, 7	2	R35	R43
Third Channel	15,14	11,12	3	R20	R27
Fourth Channel	20,19	16,17	4	R 6	R13

TABLE 3. MODULE CALIBRATION

MODULE	LOW END		HIGH END	
	Digital Input	Output Voltage	Digital Input	Output Voltage
0 to +10V	*X000	0.0000 v	*XFFF	9.9976 V
-10 to +10to	*X800	-10.0000 v	*X7FF	9.9951 v
4 to 20mA	*X000	1.0000 v	'XFFF	4.9990 v
*X = Channel number minus one in hexadecimal format. See channel number code under bits 13 and 14 of "Output Status Table Display" sheet 9.				

OUTPUT RANGE SELECTION

Each channel on the module can be set independently for an output range of 0 to + 10 V, -10 to + 10 V, or 4 to 20 mA, by configuring the on board jumpers in the positions indicated in Table 4.

Note that whenever the range of a channel is changed, the channel should be recalibrated.

TABLE 4. JUMPERS ON MODULE

OUTPUT RANGE	FIRST CHANNEL	SECOND CHANNEL	THIRD CHANNEL	FOURTH CHANNEL
0to +10v	30-31 27-28 41-42	23-24 20-21 38-39	16-17 13-14 35-36	9-10 6-7 32-33
-10 to +10v	29-30 25-27 42-43	22-23 18-20 39-40	15-16 11-13 36-37	8-9 4-6 33-34
4to20mA	30-31 26-27 41-42	23-24 19-20 38-39	16-17 12-13 35-36	9-10 5-6 32-33
4 to 20 mA output range only: For Common External Source, connect 2-3 For Internal Loop Supply, connect 1-2				

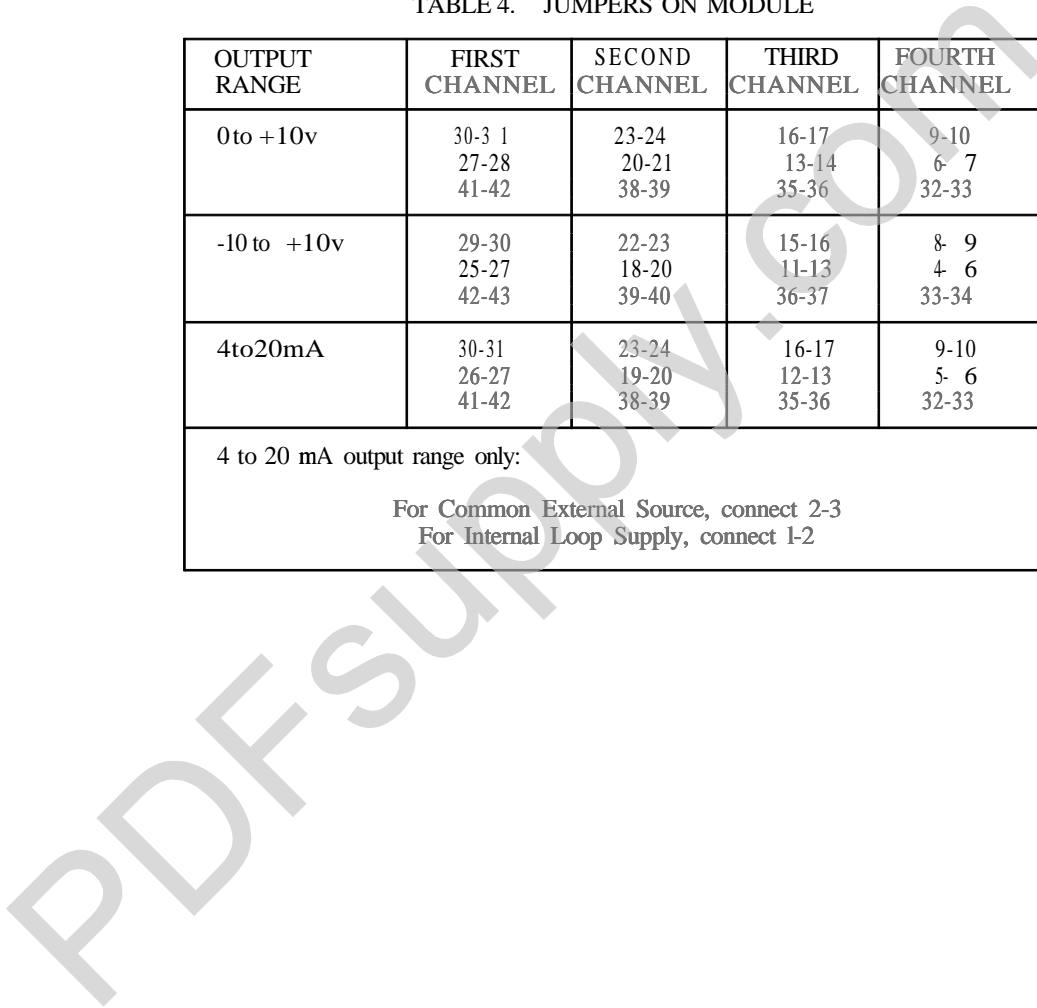

ORDERING INFORMATION

(For Local and Remote I/O applications)

<u>Module</u>	<u>Circuit Board & Faceplate</u>	<u>Circuit Board</u>	<u>Faceplate</u>
0 to +10v	IC600BF941B	IC600YB941B	IC600FP941 A
-10 to +10v	IC600BF942B	IC600YB942B	IC600FP941A
4 to 20mA	IC600BF943B	IC600YB943B	IC600FP941A
<u>Calibration Connector</u>			
IC600MA508A			

CATALOG NUMBER REVISION SUFFIX

The equipment listed above having the catalog numbers shown and the same equipment having a higher alpha suffix is designed for listing by UL for use as auxiliary control devices. The equipment is a direct replacement for equipment having the same catalog number but a lower alpha suffix.

The UL symbol on the nameplate means the product is listed by Underwriters Laboratories Inc. (UL Standard No. 508, Industrial Control Equipment, subsection Electronic Power Conversion Equipment.)

For further information, contact your local GE Fanuc sales office.

NOTE

The Analog Output module will function properly only when used with CPUs with the following serial numbers:

Model 60 CPU: C186-81350130, and higher.

Model 600 CPU: C188-8138-0100, and higher.

Model 6000 CPU: C188-8138-6000, and higher.

If your CPU has a serial number lower than that listed, contact the PC Product Service Specialist at (804) -978-5624 for assistance.

GE FANUC AUTOMATION NORTH AMERICA, INC., CHARLOTTESVILLE, VIRGINIA