

**IC600PM507**  
**New In Stock!**  
**GE Fanuc**

<http://www.pdfsupply.com/automation/ge-fanuc/ge-series-six-6/IC600PM507>

**Ge Series Six 6**  
**1-919-535-3180**

In Stock! Redundant Processor Unit Main Power Supply, 115-  
230Vac IC600P IC600PM

[www.pdfsupply.com](http://www.pdfsupply.com)

**Email:** [sales@pdfsupply.com](mailto:sales@pdfsupply.com)

GEK-84861B

### Installation

The RPU is designed to operate either with a single power supply module, or with two power supply modules. The removal and replacement guidelines of a power supply module in a dual supply system also apply to a single supply system.

When two power supply modules are used, the system offers power supply redundancy in such a way that:

- If both supply modules are functioning normally, one module has the load and the other is on standby.
- If one power supply module fails, the other either continues to carry the load or automatically assumes it without affecting the normal operation of the RPU system.
- A power supply module should be able to be removed or installed while the RPU system is up and running without interrupting the normal operation of the RPU system.
- However, because there may be live voltages on a power supply module, even after the switch to that module is turned off, the following removal and replacement guidelines should be observed.

#### Power Supply Module Replacement (RPU running)

1. Switch RUN/HOLD switch to HOLD.
2. Remove power to failed power supply by disconnecting AC source.

3. Disconnect wiring to AC and alarm terminals.
4. Remove partition faceplate between power supplies.
5. Release quarter-turn fasteners and slide power supply out to expose connectors located behind faceplate.
6. Disconnect the 4 wires from the supply chassis and 2 connectors from the monitor circuit board.
7. Remove the failed power supply.
8. Reverse the above procedure to install the replacement module.
9. After the replacement power module has been installed apply power to module and verify that the POWER-ON LED is on.
10. Switch RUN/HOLD switch to RUN.

**CAUTION**

Care should be taken to avoid shorting components or leads on the module being replaced. The free-hanging connectors from this module should also be handled or positioned in such a way that they are not brought into contact with conductive surfaces.

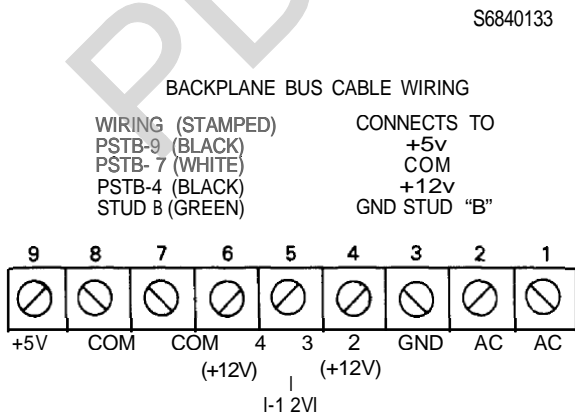

Figure 2. Power Supply Terminal Block

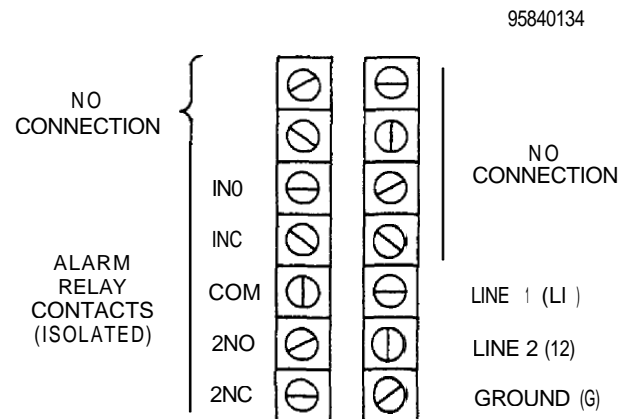

Figure 3. Front Panel Terminal Block

**CAUTION**

The alarm contacts consist of two sets of Form C contacts. The terminals marked 1 NO and 1 NC are associated with Alarm Type No. 1; the terminals marked 2 NO and 2 NC with Alarm Type No. 2. Incorrectly wiring these alarms may cause damage to your equipment (see the RPU Manual, GEK-25366, for further information on Alarm Nos. 1 and 2.)

The user devices connected to each set of alarm terminals on this module should present a resistive load drawing no more than one ampere (1A) of current at no greater than 115 Vac/28 Vdc. Failing to observe this caution may result in damage to the module.

**NOTE**

During normal operation, the alarm relays are energized. During an alarm condition, when the relay becomes de-energized, the contacts marked 1 NO and 2 NO open, and those marked 1 NC and 2NC close.

**NOTE**

The two keystrokes (Run/Hold, Pwr/Auto/CPU2) depend on the Main Power Supply for their circuits. If the Main Power Supply fails, the RPU firmware will behave as though the Run/Hold keyswitch has been switched to Hold, even if an Auxiliary Power Supply is present.

**Table 3. Ordering Information**

DESCRIPTION	CATALOG NUMBER
95-260Vac Main Power Supply	IC600PM507
24 Vdc Main Power Supply	IC600PM543

The UL symbol on the nameplate means the product is listed by Underwriters Laboratories Inc. (UL Standard No. 508, Industrial Control Equipment, subsection Electronic Power Conversion Equipment.)

For further information, contact your local GE Fanuc sales representative.