

IC600YB944
New In Stock!
GE Fanuc

<http://www.pdfsupply.com/automation/ge-fanuc/ge-series-six-6/IC600YB944>

Ge Series Six 6
1-919-535-3180

In Stock! 12K ASCII/Basic I/O Module IC600Y IC600YB

www.pdfsupply.com

Email: sales@pdfsupply.com

GEK-90758A

Table I. FEATURES AND BENEFITS

FEATURES	BENEFITS
GE/BASIC	An interpretive extended BASIC language which makes programming easy and flexible.
Full function floating point math.	Used in solving complex mathematical algorithms.
Dual communication ports.	Permits simultaneous and independent communications between the module and two external devices.
12K or 28K bytes of user memory, battery-backed.	Fully user addressable for storage of user program. Requires no CPU memory.
Special commands for CPU interface.	Easy, controlled access to all CPU input, output, and Register data.
Interrupts/Timers	16 software interrupts from CPU or internal timers or events.
8-character variable names.	Permits user recognizable variable names.
Status indicators.	Used for module diagnostics and to indicate serial data flow in/out.
Interfaces to STR-LINK IIA and III devices.	Enables programs to be easily stored, retrieved and verified.
Internal time/date.	Facilities report generation and time/date dependent activities.

Module Specifications	
Space Requirements:	One Series Six I/O slot in either a Model 60 CPU rack or a High-Capacity I/O rack
Power Requirements:	+ 5 Vdc, + 12 Vdc (Supplied by rack power supply) 5 Vdc -20 unit loads
Storage Temperature:	0 to 70°C
Operating Temperature:	0 to 60°C
Humidity:	5% - 95% (non-condensing)
Altitude:	Up to 10,000 feet (3,000 meters) above sea level (operating)
Isolation:	(Port to Port and either Port to Series Six common). Transient: 1500 Vac, 50/60 Hzs for 1 minute maximum, non repetitive. Continuous: 240 Vdc or RMS ac, 50/60 Hzs.
Noise & Transient Immunity:	Meets following specifications Showering arcs per NEMA ICS 2,230.40 Surges per ANSI C37.90.9 5 W R.F. transmitter 27-450 Mhz
RS-232C/RS-422 Cable Specifications	
≡≡ Length, Maximum:	50 feet (15 meters) for RS-232C 4000 feet 11.2 Km) for RS-422
≡≡ Overall Shield Recommended	
≡≡ 24 AWG Minimum	
≡≡ Mating connector to Port 1 or Port 2 is a D-Subminiature Type. Cannon DB25P (Solder Pot) with DB11096B-3 Hood or Equivalent. (Standard RS-232C male connector.)	
≡≡ RS-422 Cable Selection	
The following cables provide acceptable operation at data rates up to 19.2K BPS and up to 4000 feet:	
Belden	9184
Belden	9302
NEC	222P 1 SLCBT
At shorter distances, almost any twisted pair or shielded twisted pair will work. It should be noted that RS-422 requires that the transmitter and receiver ground be within a few volts of each other or damage to the transmitter and receiver may result.	
It is also noted that the twisted pairs should be matched so that both transmit signals make up one twisted pair and both receive signals make up the other twisted pair. If this is ignored, then cross-talk can result from the mismatching which will affect the performance of the communication system.	

FIGURE 1. SPECIFICATIONS

GEK-90758A

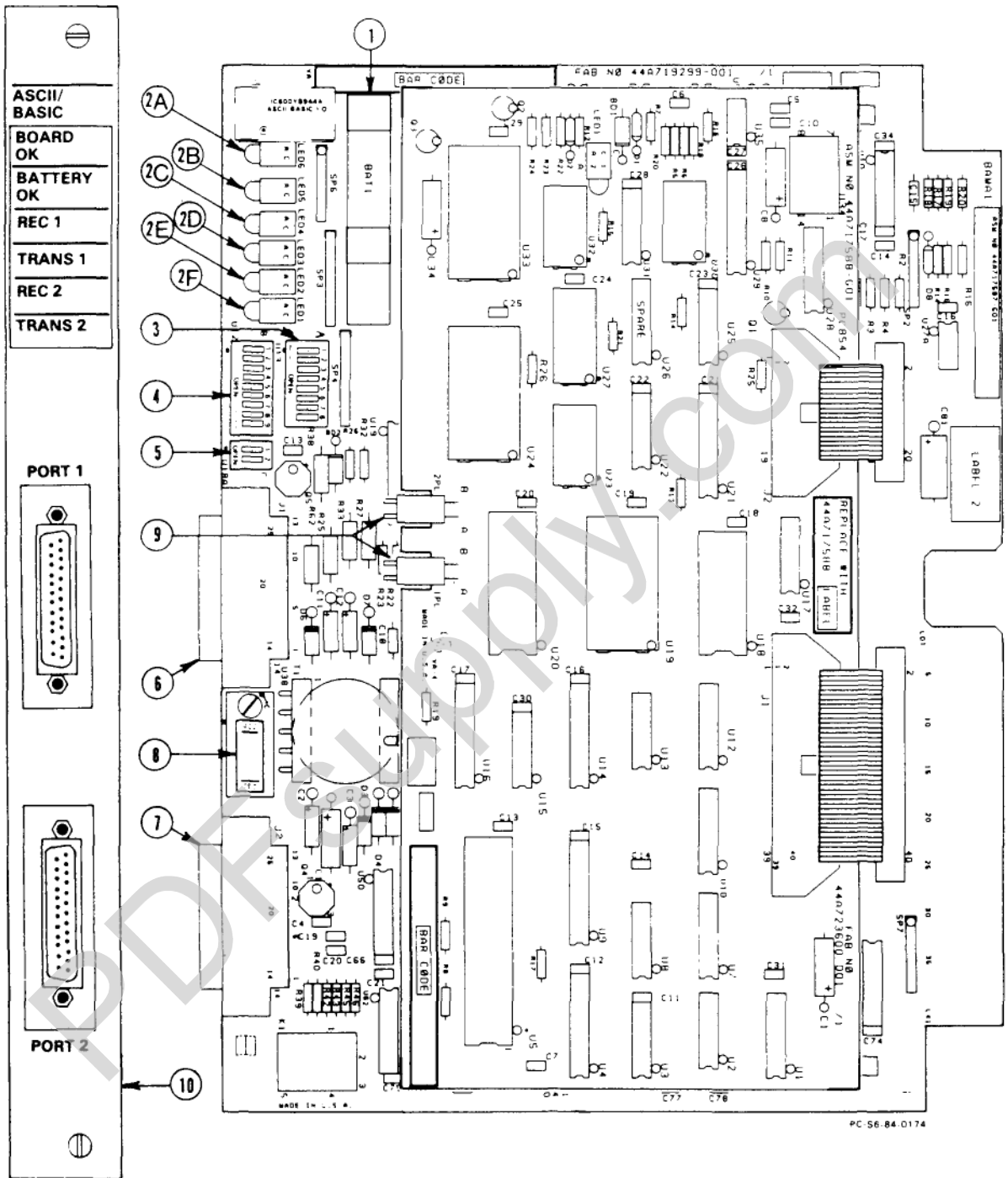

FIGURE 2. USER ITEMS (Part 1 of 2)

- ① Lithium-Manganese Dioxide Battery
- ② LED Status Indicators (see below)
- ③ Bank A DIP Switches
- ④ Bank B DIP Switches
- ⑤ Bank C DIP Switches
- ⑥ J1 Connector: 25-pin D-type female connector (Programming Port 1).
- ⑦ J2 Connector: 25-pin D-type female connector (Communications Port 2).
- ⑧ J2 Communication selection DIP package: RS-232 or RS-422 configuration read from top of imprinted label.
- ⑨ Battery connectors
- ⑩ Faceplate

LED	DESCRIPTION
(2A) BOARD OK	ON: Board has passed self-diagnostics and is operating properly. OFF: Indicates a failure.
(2B) BATTERY OK	ON: Lithium battery voltage within limits. FLASHING: Battery performance marginal, replace battery. OFF: Lithium battery will not maintain user memory program in RAM.
(2C) REC 1	ON: Serial data present at receiver 1 input. OFF: Receiver 1 input inactive.
(2D) TRANS 1	ON: Serial data present at transmitter 1 output. OFF: Transmitter 1 output inactive.
(2E) REC 2	ON: Serial data present at receiver 2 input. OFF: Receiver 2 input inactive.
(2F) TRANS 2	ON: Serial data present at transmitter 2 output. OFF: Transmitter 2 output inactive.

FIGURE 2. USER ITEMS (Part 2 of 2)

GEK-90758A

INSTALLATION

The ASCII/BASIC module must be installed in a Series Six High-Capacity I/O rack or in a Model 60 CPU rack. Being an intelligent device, the ASCII/BASIC module can function independently of the CPU. As such, if communications with the CPU are not required, the module may be located in a High Capacity I/O rack in a remote I/O subsystem. Before installing the module, set the Dual-In-Line Package (DIP) switches adjacent to the card slot on the rack backplane to establish which group of eight consecutive input and output points in the CPU I/O tables will be used by the module being installed. For further information on I/O DIP switch settings, refer to Figure 3 and Table 2.

Set the DIP switch banks A,B and C (user items 3,4 and 5 on Figure 2) on the module to the required configurations (see Figures 5a, 5b and 5c). Verify the position of the configuration hybrid DIP package located between J1 and 52, it is user item 4 on Figure 2. It is marked "232" on one end and "422" on the other and is mounted on a socket. A small screwdriver is needed to turn the screw which releases the configuration hybrid DIP package from the

socket. Position the package so as to provide either RS-232 or RS-422 communications on the lower port (Port 2). The selected communications mode may be read off the surface of the package. The mode selected will appear right-side up.

Use the extraction/insertion tool furnished with the Series Six rack to remove or install the module.

Guide the faceplate over the circuit board so that the proper contact is made. Then secure the faceplate to the rack using the thumbscrews at the top and the bottom. Power may now be applied to the module and terminals or other external ASCII devices may be connected to Port 1 and/or Port 2. The pinout definitions for Port 1 and Port 2 are defined in Table 3.

There are many devices to which this module can be connected and numerous ways to wire up these connections. A few of the more common wiring connections are shown in Figures 4(a)-(d).

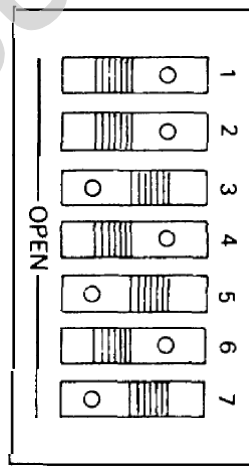

PC-S6-83-0126

FIGURE 3. TYPICAL I/O BACKPLANE DIP SWITCH

TABLE 2. DIP SWITCH SETTINGS FOR I/O POINT SELECTION FOR THE ASCII/BASIC MODULE

DPREQ REGISTER CONTENTS DECIMAL (HEX)	I/O POINT	DIP SWITCH POSITION							DPREQ REGISTER CONTENTS DECIMAL (HEX)	I/O POINT	DIP SWITCH POSITION						
		7	6	5	4	3	2	1			7	6	5	4	3	2	1
1001 (03E9)	1- 8								1505 (05E1)	505- 512		X	X	X	X	X	X
1009 (03F1)	9- 16							X	1513 (05E9)	513- 520	X						
1017 (03F9)	17- 24						X		1521 (05F1)	521- 528	X						X
1025 (0401)	25- 32						X	X	1529 (05F9)	529- 536	X						X
1033 (0409)	33- 40					X			1537 (0601)	537- 544	X						X
1041 (0411)	41- 48					X		X	1545 (0609)	545- 552	X				X		
1049 (0419)	49- 56					X	X		1553 (0611)	553- 560	X				X		X
1057 (0421)	57- 64					X	X	X	1561 (0619)	561- 568	X				X	X	
1065 (0429)	65- 72				X				1569 (0621)	569- 576	X			X	X	X	
1073 (0431)	73- 80				X			X	1577 (0629)	577- 584	X			X			
1081 (0439)	81- 88				X		X		1585 (0631)	585- 592	X			X			X
1089 (0441)	89- 96				X		X	X	1593 (0639)	593- 600	X			X			X
1097 (0449)	97- 104				X	X			1601 (0641)	601- 608	X			X	X	X	X
1105 (0451)	105- 112				X	X	X		1609 (0649)	609- 616	X			X	X	X	
1113 (0459)	113- 120				X	X	X		1617 (0651)	617- 624	X			X	X	X	X
1121 (0461)	121- 128				X	X	X	X	1625 (0659)	625- 632	X			X	X	X	X
1129 (0469)	129- 136			X					1633 (0661)	633- 640	X			X	X	X	X
1137 (0471)	137- 144			X				X	1641 (0669)	641- 648	X	X					
1145 (0479)	145- 152			X			X		1649 (0671)	649- 656	X	X					X
1153 (0481)	153- 160			X			X	X	1657 (0679)	657- 664	X	X					X
1161 (0489)	161- 168			X		X			1665 (0681)	665- 672	X	X					X
1169 (0491)	169- 176			X	X	X	X		1673 (0689)	673- 680	X	X	X				X
1177 (0499)	177- 184			X	X	X	X		1681 (0691)	681- 688	X	X	X				X
1185 (04A1)	185- 192			X	X	X	X	X	1689 (0699)	689- 696	X	X	X	X			X
1193 (04A9)	193- 200			X	X				1697 (06A1)	697- 704	X	X	X	X	X		X
1201 (04B1)	201- 208			X	X		X		1705 (06A9)	705- 712	X	X	X	X			X
1209 (04B9)	209- 216			X	X	X	X		1713 (06B1)	713- 720	X	X	X				X
1217 (04C1)	217- 224			X	X	X	X	X	1721 (06B9)	721- 728	X	X	X	X			X
1225 (04C9)	225- 232			X	X	X			1729 (06C1)	729- 736	X	X	X	X			X
1233 (04D1)	233- 240			X	X	X	X	X	1737 (06C9)	737- 744	X	X	X	X			X
1241 (04D9)	241- 248			X	X	X	X	X	1745 (06D1)	745- 752	X	X	X	X			X
1249 (04E1)	249- 256			X	X	X	X	X	1753 (06D9)	753- 760	X	X	X	X	X		X
1257 (04E9)	257- 264			X					1761 (06E1)	761- 768	X	X	X	X	X	X	X
1265 (04F1)	265- 272			X				X	1769 (06E9)	769- 776	X	X					
1273 (04F9)	273- 280			X			X		1777 (06F1)	777- 784	X	X					X
1281 (0501)	281- 288			X			X	X	1785 (06F9)	785- 792	X	X					X
1289 (0509)	289- 296			X		X			1783 (0701)	793- 800	X	X					X
1297 (0511)	297- 304			X		X	X		1801 (0709)	801- 808	X	X			X		X
1305 (0519)	305- 312			X	X	X	X		1809 (0711)	809- 816	X	X	X				X
1313 (0521)	313- 320			X	X	X	X	X	1817 (0719)	817- 824	X	X			X	X	X
1321 (0529)	321- 328			X	X				1825 (0721)	825- 832	X	X			X	X	X
1329 (0531)	329- 336			X	X		X		1833 (0729)	833- 840	X	X	X				
1337 (0539)	337- 344			X	X	X	X		1841 (0731)	841- 848	X	X	X				X
1345 (0541)	345- 352			X	X	X	X	X	1849 (0739)	849- 856	X	X	X	X			X
1353 (0549)	353- 360			X	X	X			1857 (0741)	857- 864	X	X	X	X			X
1361 (0551)	361- 368			X	X	X	X		1865 (0749)	865- 872	X	X	X	X			
1369 (0559)	369- 376			X	X	X	X	X	1873 (0751)	873- 880	X	X	X	X	X		X
1377 (0561)	377- 384			X	X	X	X	X	1881 (0759)	881- 888	X	X	X	X	X	X	X
1385 (0569)	385- 392			X	X				1889 (0761)	889- 896	X	X	X	X	X	X	X
1393 (0571)	393- 400			X	X		X		1897 (0769)	897- 904	X	X	X				
1401 (0579)	401- 408			X	X		X		1905 (0771)	905- 912	X	X	X				X
1409 (0581)	409- 416			X	X		X	X	1913 (0779)	913- 920	X	X	X				X
1417 (0589)	417- 424			X	X	X			1921 (0781)	921- 928	X	X	X				X
1425 (0591)	425- 432			X	X	X	X		1929 (0789)	929- 936	X	X	X	X			
1433 (0599)	433- 440			X	X	X	X	X	1937 (0791)	937- 944	X	X	X	X	X		X
1441 (05A1)	441- 448			X	X	X	X	X	1945 (0799)	945- 952	X	X	X	X	X	X	X
1449 (05A9)	449- 456			X	X	X			1953 (07A1)	953- 960	X	X	X	X	X	X	X
1457 (05B1)	457- 464			X	X	X		X	1961 (07A9)	961- 968	X	X	X	X			
1465 (05B9)	465- 472			X	X	X	X		1969 (07B1)	969- 976	X	X	X	X	X		X
1473 (05C1)	473- 480			X	X	X	X	X	1977 (07B9)	977- 984	X	X	X	X	X	X	X
1481 (05C9)	481- 488			X	X	X	X		1985 (07C1)	985- 992	X	X	X	X	X	X	X
1489 (05D1)	489- 496			X	X	X	X	X	1993 (07C9)	993- 1000	X	X	X	X	X	X	X
1497 (05D9)	497- 504			X	X	X	X	X									

* For programming use only: add 1000 to I/O points.

X = Switch in OPEN Position (Depressed to the Left).

GEK-90758A

TABLE 3. ASCII/BASIC MODULE PORT CONNECTOR PINOUTS

PIN	PROGRAMMING PORT (J1)	COMMUNICATIONS PORT (J2)
1	NC	NC
2	Data Out RS-232	Data Out RS-232
3	Data In RS-232	Data In RS-232
4	NC	RTS or Tx Clock Out (RS-232)
5	NC	CTS or Rx Clock In (RS-232)
6	NC	NC
7	Ground	Ground
8*	Data Out(+) I Loop	CD or Tx Clock In (RS-232)
9	Ground	Ground
10#	Data Out(+) RS-422	Data Out(+) RS-422
11	Data In (+) RS-422	Data In (+) RS-422
12	I Src(+) Rx	CTS(+) or Rx Clock In(+) (RS-422)
13*	I Src(+) Tx	CD (+) or Tx Clock In(+) (RS-422)
14	NC	Output Relay -Normally Closed
15+	RS-232 JMP 1	Output Relay -Normally Open
16+	RS-232 JMP 2	Output Relay -Common
17	Term. Rx RS-422	Terminate Rx RS-422
18	Data In(+) I Loop	Terminate CTS RS-422
19	Data In(-) I Loop	Terminate CD RS-422
20	NC	NC
21	Data Out(-) I Loop	NC
22#	Data Out(-) RS-422	Data Out(-) RS-422
23	Data In (-) RS-422	Data In (-) RS-422
24	I Src(-) Rx	CTS(-) or Rx Clock In(-) (RS-422)
25*	I Src(-) Tx	CD (-) or Tx Clock In(-) (RS-422)

* CD = Carrier Detect (or RLSD = Receive Line Signal Detect).

+ Optional connection for Port 1 only, as switch in DIP bank C can be set to make this connection.

RS-422 transmit signals for the communications port are tri-stated for multi-drop links when the transmitter is active.

The dual-purpose pins have no function until they are determined by the user's software.

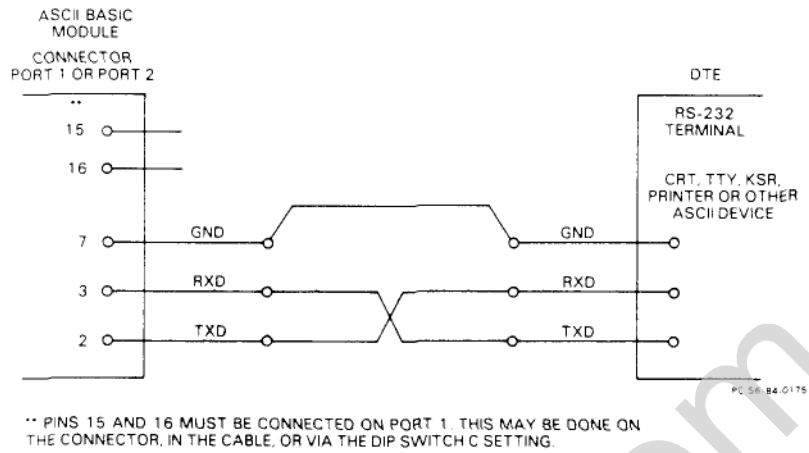

FIGURE 4(a). ASYNCHRONOUS RS-232 POINT-TO-POINT

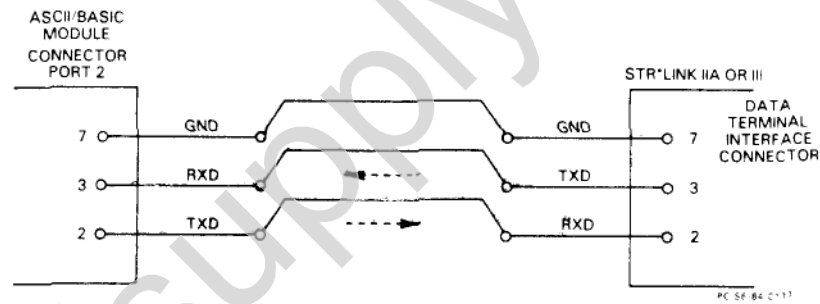

FIGURE 4(b). STR*-LINK CABLE

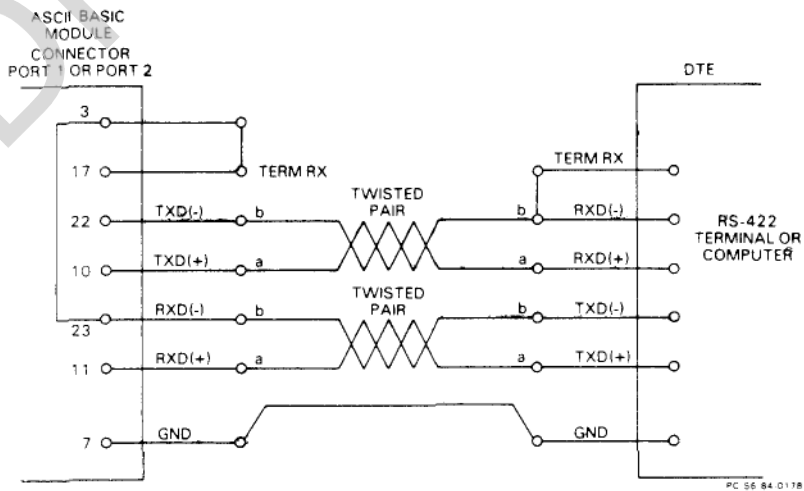
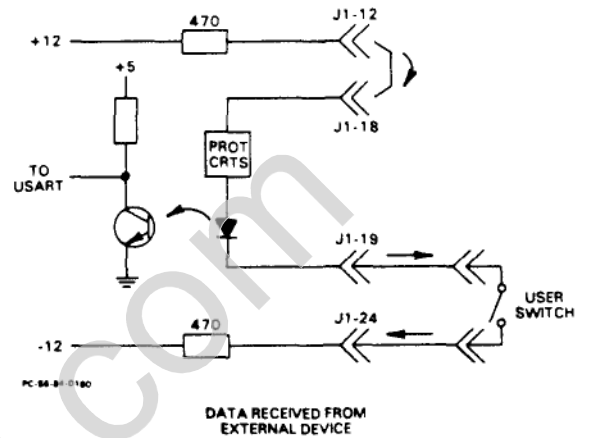
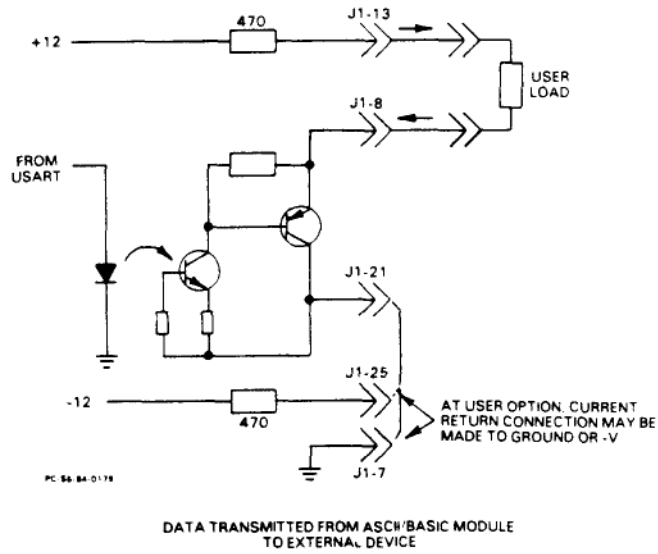

FIGURE 4(c). ASYNCHRONOUS RS-422 POINT-TO-POINT

*Trademark of Electronic Processors Inc.
Ref. PC-S6-84-0175
PC-S6-84-0177
PC-S6-84-0178

GEK-90758A



ACTIVE CURRENT LOOP

FIGURE 4(d). CURRENT LOOP POINT-TO-POINT (Part 1 of 2)

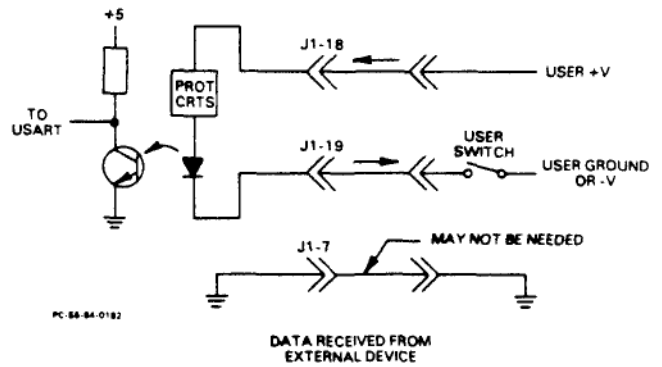
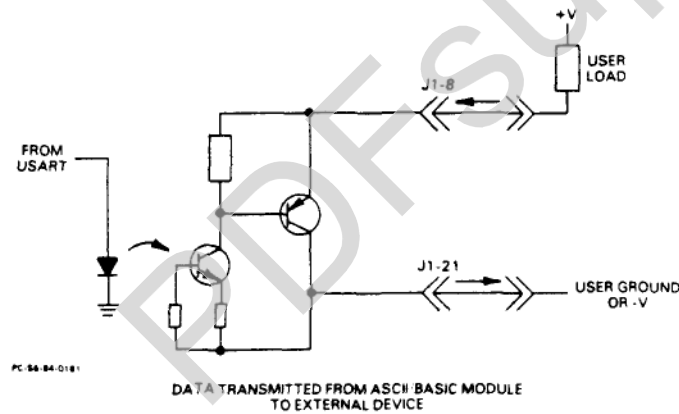

PASSIVE CURRENT LOOP

FIGURE 4(d). CURRENT LOOP POINT-TO-POINT (Part 2 of 2)

Ref. PC-S6-84-0179
 PC-S6-84-0180
 PC-S6-84-0181
 PC-S6-84-0182

Configuration

The settings of the DIP switches which configure Port 1 and perform other miscellaneous set up functions are:

TABLE 4 (a). BANK A DIP SWITCHES

1	2	3	
closed	closed	closed	BANK A Switch (Data Rate Selection)
*open	*open	*open	19.2K BPS
closed	open	open	9600 BPS
open	closed	open	4800 BPS
closed	closed	open	2400 BPS
open	open	closed	1200 BPS
closed	open	closed	600 BPS
open	closed	closed	300 BPS
			110 BPS
4	5	6	
*open	*open	*open	BANK A Switch (Framing and Parity Selection)
closed	open	open	7 data bits, parity bit - even
open	closed	open	7 data bits, no parity bit
closed	closed	open	7 data bits, parity bit - odd
open	open	closed	8 data bits, eighth bit = 1, no parity bit
closed	open	closed	8 data bits, parity bit - even
open	closed	closed	8 data bits, eighth bit = 0, no parity bit
closed	closed	closed	8 data bits, parity bit - odd
			8 data bits, no parity bit
7	8		
*open	*open		BANK A Switch (Full and Half-Duplex and type of echo)
closed	open		Half duplex, send echo
open	closed		Reserved
closed	closed		Half duplex, no echo
			Full duplex, no echo

* Indicates the factory-set default position.

GEK-90758A

TABLE 4 (b). BANK B DIP SWITCHES

1	BANK B Switch *open RS-232-C/RS-422 selected for Port No.1 closed 20 mA Current Loop selected for Port No. 1
2	BANK B Switch *open 1 stop bit to be used on Port No. 1 closed 2 stop bits to be used on Port No. 1
3	BANK B Switch *open Port No. 1 MARK/SPACE invert disabled closed Port No. 1 MARK/SPACE invert enabled
4	BANK B Switch *open Port No. 1 BS/DEL editing enabled closed Port No. 1 BS/DEL editing disabled
5	BANK B Switch *open Port No. 1 Xon/Xoff flow control disabled closed Port No. 1 Xon/Xoff flow control enabled
6	BANK B Switch *open Program Mode Enabled closed Program Protected
8	BANK B Switch *open Execute operational software closed Execute factory test software
9	BANK B Switch *open ASCII/BASIC Module is enabled. (operations resume in PROGRAM mode) closed ASCII/BASIC Module is reset.

* Indicates the factory-set default position.

TABLE 4 (c). BANK C DIP SWITCH

1	<p>BANK C Switch</p> <p>open Disconnects Pins 15, 16 for Port 1 RS-422</p> <p>*closed Connects Pins 15 and 16 for Port 1 RS-232-C operation (use external jumper if desired across pins 15-16)</p>
---	--

* Indicates the factory-set default position.

Options available for Port 2 setup by user's BASIC program include:

- RS232 or RS422
- Any data rate between 75 and 19200 BPS
- 5 thru 8 data bits per character
- 1 or 2 stop bits
- Even, odd, or no parity
- Interactive editing enabled/disabled
- Internal or external clock or clock derived from data stream
- No encoding or NRZI encoding

SERIAL DATA FORMAT

Asynchronous Data Character Format:

START ---- DATA BITS ---- PARITY BIT ---- STOP BIT
 BIT (UP TO 8) (OPTIONAL) (1 OR 2)

GEK-90758A

ASCII/BASIC MODULE - SERIES SIX INTERFACE

The eight input points in the Series Six CPU which correspond to the address of an ASCII/BASIC module are used to provide the CPU with the status of the module.

The eight output points at this address may be used by the CPU logic to control the ASCII/BASIC module.

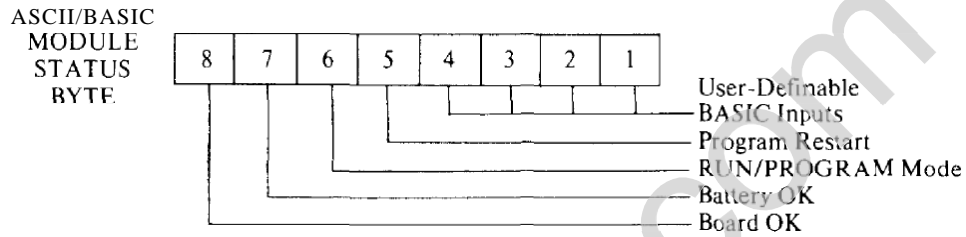

FIGURE 5(a). MODULE STATUS DATA IN SERIES SIX INPUT TABLE

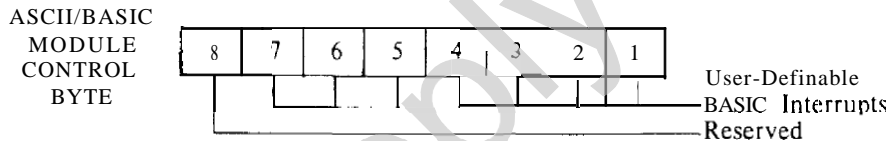

FIGURE 5(b). MODULE CONTROL DATA IN SERIES SIX OUTPUT TABLE

MODULE CHECKOUT USING **V104** CPU SOFTWARE

1. Connect terminal to be used for programming and checking out this module to Port 1.
2. Set ASCII/BASIC module address switches for the desired I/O address.
3. Configure Port 1 DIP switches as required for terminal connected in step 1.
4. Bank B switches 6-9 should be open.
5. Bank B switch 6 must be open (program not protected position) and the CPU Memory Protect/Write Enable keyswitch must be in the Write Enable position to allow a program to be entered into the ASCII/BASIC module.

Program the Series Six CPU with the following ladder diagram for the checkout:



In this program, an ASCII/BASIC module will be serviced if output Oxxxx is on. The content of Rnnnn (note: this is shown as Hexadecimal number HHHH) must lie between + 1001 and + 2000 decimal. The contents of this register will correspond to the first I/O point address of the ASCII/BASIC module plus 1000 decimal. Example: If the ASCII/BASIC module address switches are set for I/O points 1-8, then HHHH should be 03E9 (decimal value is 1001).

If the ASCII/BASIC module is serviced without fault, the output Oyyyy will remain off. If a fault occurs while the Module is being serviced, Oyyyy will turn on.

7. If a "*" prompt character appears on the programming terminal connected in step 1 above, BASIC programs may be entered into the ASCII/BASIC module and the programs may be edited from the terminal. If the "*" character is not present, the programming mode may be entered by sending Control/C to Port 1.
8. Enter the following BASIC program via the programming terminal to check data transfer between the ASCII/BASIC module and the Series Six CPU:

```

10 CLEAR
20 REGNO% = 2: ! use any free register in the Series Six.
30 SDATA% = X'AA55': ! use this as data pattern.
40 SETW REG REGNO%,1,SDATA%,0,RETF%: ! send contents of SDATA% to Reg 2.
50 1% = DELAY%(20): ! allow plenty of time for write transfer.
60 IF RETF% > 0 THEN 80: ! success, if RETF% is greater than zero.
70 PRINT "WINDOW FAILURE : ASCII/BASIC MODULE TO CPU":STOP
80 SETR REG REGNO%,1,RDATA%,0,RETF1%: ! read back Reg 2 into RDATA%.
90 1% = DELAY%(20): ! allow plenty of time for read transfer.
100 IF RETF1% > 0 THEN 120: ! success, if RETF1% is greater than zero.
110 PRINT "WINDOW FAILURE : CPU TO ASCII/BASIC MODULE":STOP
120 PRINT "DATA TRANSFER BETWEEN CPU AND ASCII/BASIC MODULE IS OK"
130 END
  
```

9. Enter the RUN command into the terminal to execute the program listed above.
10. Upon completion of the above program, you will receive one of the following messages on the programming terminal:
 - a. If OK - "DATA TRANSFER BETWEEN CPU AND ASCII/BASIC MODULE IS OK"
 - b. If data was not successfully sent from the CPU to the ASCII/BASIC Module . . . -"WINDOW FAILURE : CPU TO ASCII/BASIC MODULE"
 - c. If data was not successfully sent from the ASCII/BASIC MODULE TO THE CPU- . . -"WINDOW FAILURE : ASCII/BASIC MODULE TO CPU"
 - d. An error message- -refer to the ASCII/BASIC Module programming reference manual (GEK-25398).
11. Correct any errors found and run program again until data transfer is OK.

GEK-90758A

BASIC SUMMARY

The following tables show the operators, format control characters, functions and types of statements which are available in BASIC.

For more detail refer to the ASCII/BASIC Module Manual, GEK 25398.

TABLE 5. OPERATORS

Arithmetic	Relational	Logical
-	=	NOT
^	>	AND
*	>=	OR
/	<	XOR
+	<=	
-	<>	
	=&	
String		Assignment
&		=
+		

TABLE 6. FORMAT CONTROL CHARACTERS

SYMBOL	CHARACTER FUNCTION
Z	Zero Suppression
9	Digit Position, including zero
.	Decimal Point
,	Insertion Character
+	Signum Printed (+ or -)
-	Minus Only Printed
CR	CR Printed for Minus
B	Blank Insertion
\$	Floating Dollar
*	Asterisk Check Protect

TABLE 7. FUNCTIONS

Arithmetic		
ABS (X)	LOG (X)	ATN (X)
INT(X)	EXP (X)	COS(X)
SGN (X)	SQR(X)	SIN(X)
MOD (M%,N%)	RND	TAN (X)
String and Data		
ADD% (X)	ASC% (A\$)	AS2% (A\$)
CHR\$(X)	CH2\$(X)	FLL\$(X,A\$)
IND% (A\$,B\$)	LEN% (X\$)	SPC\$(X)
STR\$(N)	TAB(X)	VAL(X\$)
	@ (R% C%)	
System		
ERN%	ERL%	SPR%
ISR% (N%)	INKEY\$(A%)	INLEN% (A%)
SETTIME% (A\$)	TIME\$	TIMER% (I%,X%)
SETDATE% (A\$)	DATE\$	DELAY% (I%)
INTR% (A%,B%,C%)		STATUS%(A%,B%,C%)
User		
	FNAs(v,...)	
Conversion		
SSDP# (A%(1))		EXTP%(A# ,A%(1))

TABLE 8 STATEMENTS

CLEAR	Assignment
COPYW A%,B%,C%	LET v=e or v=e
SETW TYPE B%,C%,D%,E%,F%	COPYL A%, B%,C%
SETPW TYPE B%,C%,F%	SETR TYPE B%,C%,D%,E%,F%
	RANDOMIZE
REM remarks	Definition
DEF FNAs(v,...)	!remarks
SUBR name(v,...)	DIM v(x,y),...
OPTION	STRUC (v,P%,e1 ,e2)
	Edit
RENUM n,i	n\a\b
n	nl,n2
	Program Control
END	STOP
GOTO n	ON e GO TO n,...
GO SUB n	RETURN
ON e GOSUB n,...	RETURN n
CALL name(e,...)	RETURN FROM
CALL ASM(e,...)	
IF e THEN n	IF e THEN n1 ELSE n2
IF e THEN s	IF e THEN s1 ELSE s2
FOR v=e1 TOe2	NEXT v
FORv=e1TOe2STEPe3	
FOR...WHILE	
FOR...UNTIL	
	Input/Output
DATA c1,c2,...	READ v1,v2,...[ONERR n]
RESTORE	RESTORE n
INPUT v1,v2,... [ONERR n]	PRINT e1,e2,... [ONERR n]
INPUT1 v1,v2,... [ONERR n1]	PRINT1 e1,e2,... [ONERR n]
INPUT2 v1,v2,...[ONERR n1]	PRINT2 e1,e2,... [ONERR n]
PEEK (1%)	POKE I%,A%
DIN (1%)	DOUT I%,A%
	System Control
RUN	RUN < ESC >
CONT	PAUSE
NEW 'name'	NAME 'name'
LIST	LIST n,
LIST n	LIST n1,n2
LIST 1	LIST1 n,
LIST1 n	LIST1 n1,n2
LIST2	LIST2 n,
LIST2 n	LIST2 n1 ,n2
SAVE 'name/dev'	VERIFY 'name/dev'
LOAD 'name/dev'	SETPR2 A%,B%,C%,D%,E%,F%,G%,H%,I%

ORDERING INFORMATION

<u>Circuit Board and Faceplate</u>	<u>Circuit Board</u>	<u>Faceplate</u>
12K Version IC600BF944A	IC600YB944A	IC600FP944A
28K Version IC600BF949		

CATALOG NUMBER REVISION SUFFIX

The equipment listed above having the catalog numbers shown and the same equipment having a higher alpha suffix is designed for listing by UL for use as auxiliary control devices. The equipment is a direct replacement for equipment having the same catalog number but a lower alpha suffix.

- Ⓢ The UL symbol on the nameplate means the product is listed by Underwriters Laboratories Inc. (UL Standard No, 508, Industrial Control Equipment, subsection Electronic Power Conversion Equipment.)

For further information, contact your local GE Fanuc sales office.