

IC600YR550
New In Stock!
GE Fanuc

<http://www.pdfsupply.com/automation/ge-fanuc/ge-series-six-6/IC600YR550>

Ge Series Six 6
1-919-535-3180

In Stock! Input Output Rack Old Version IC600Y IC600YR

www.pdfsupply.com

Email: sales@pdfsupply.com

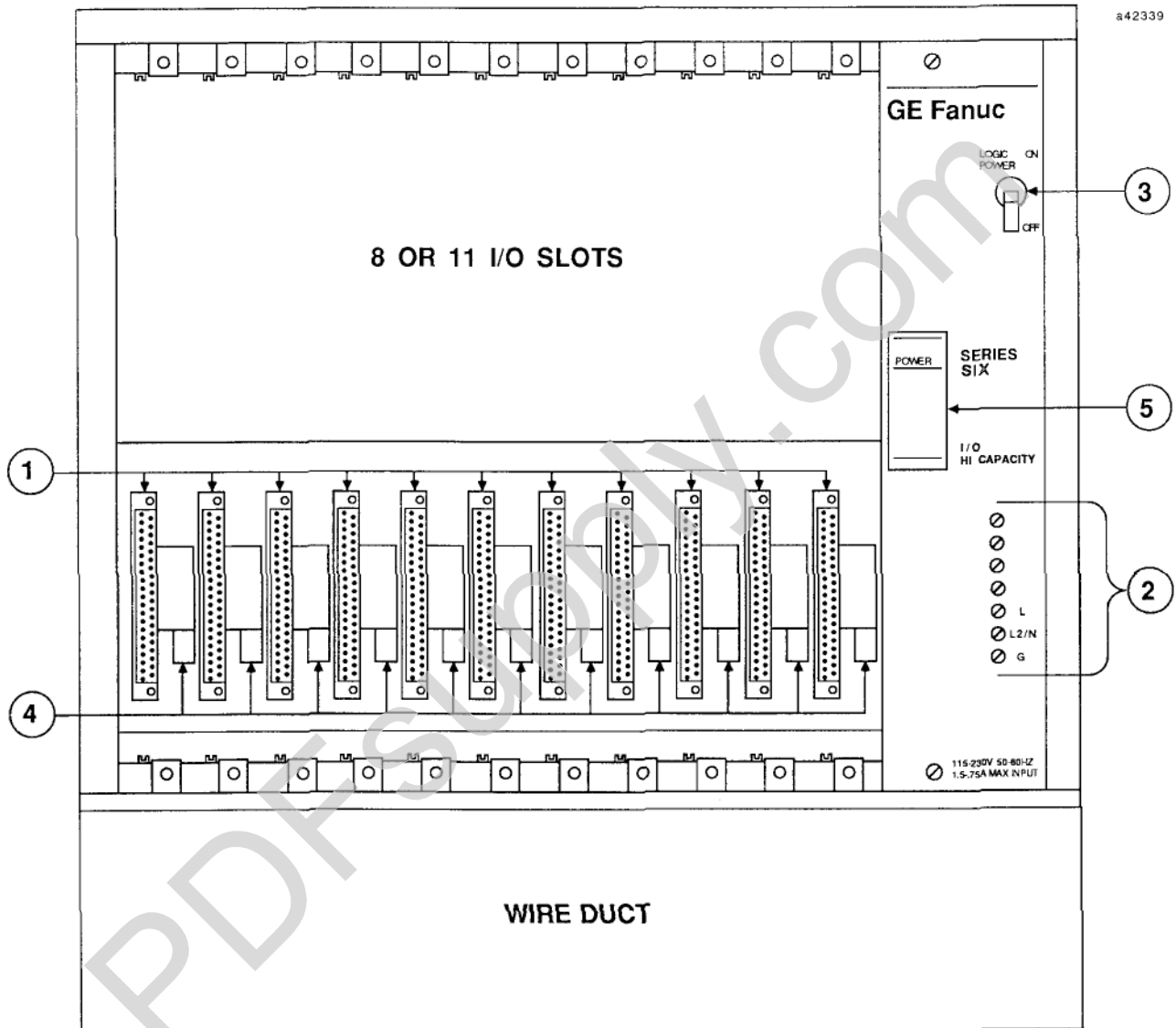

1. 41P-PIN BACKPLANE CONNECTOR MATES WITH CONNECTOR ON A PLUG-IN MODULE.
2. POWER-SUPPLY FRONT-PANEL TERMINAL BLOCK. SEE "INSTALLATION" SECTION AND FIGURE 3 OF THIS DATA SHEET.
3. LOGIC-POWER SWITCH

4. DIP SWITCHES TO SET I/O MODULE ADDRESS
5. POWER LIGHT
 - A. ON: THE DC VOLTAGE OUTPUT OF THE POWER SUPPLY IS WITHIN TOLERANCE
 - B. OFF: DC VOLTAGE IS OUT OF TOLERANCE

Figure 1. USER ITEMS

GFK-0148A

Installation

The following procedures summarize the proper installation of the I/O rack. Further details on each step can be found in the Series Six Plus Users Manual GEK-96602.

1. The I/O rack can be rack-mounted or panel-mounted. The location and orientation of the mounting brackets depends on the mount. Refer to Figure 3.

WARNING

Extreme care should be taken when making connections to the terminal block . . . High voltage AC or DC may be present.

2. Refer to Figure 3. Connect a power cord capable of carrying the current drawn by the power supply to the terminal block on the front panel. Safety ground and signal ground connections must be made as described in the Series Six Plus Users Manual. Ensure that the input voltage jumper is positioned correctly and secured (Standard I/O rack only). After the connections have been made, mount the protective cover over the terminal block with the screws provided; make sure that the wires are routed through the opening in the cover.

3. Install an I/O Receiver module (or Remote I/O Receiver) in the card slot at the extreme left in the rack if this is the first rack in a Remote station.
4. Any combination of Input, Output, I/O Transmitter **and/or** Remote I/O Driver modules can be installed in the other card slots in the rack, after the DIP switches (Figure 4) for each have been set to the appropriate address as indicated in Figure 5. Note that an optional wiring trough is available to facilitate field-wiring to the various modules.

NOTE

If the POWER LED does not light at power-up, or intermittent errors occur in the course of operation, the current-rating of the I/O rack could be exceeded. Refer to Table 2 to determine the total current requirements within a rack.

NOTE

See outline drawings on pages 5-8.

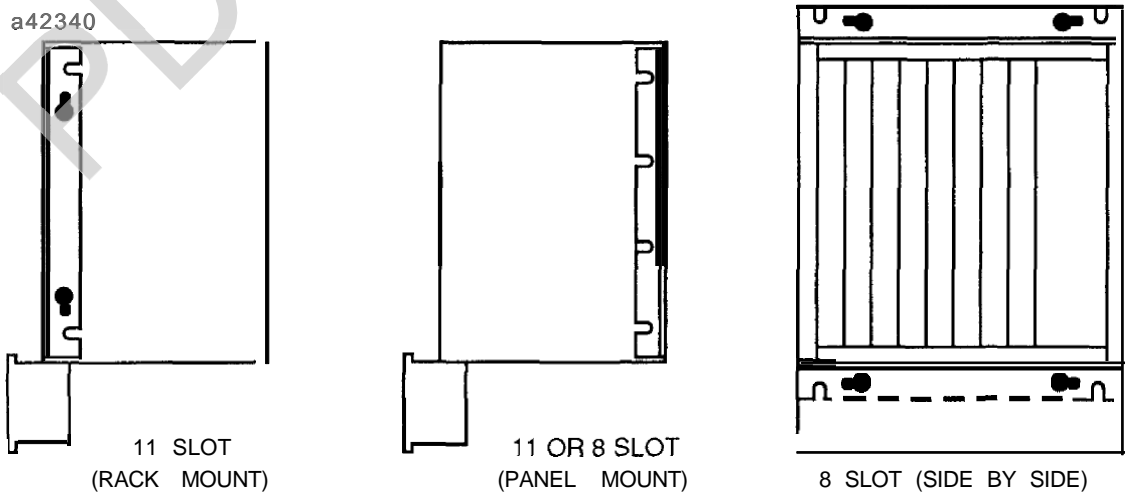

Figure 2. USE OF MOUNTING BRACKETS

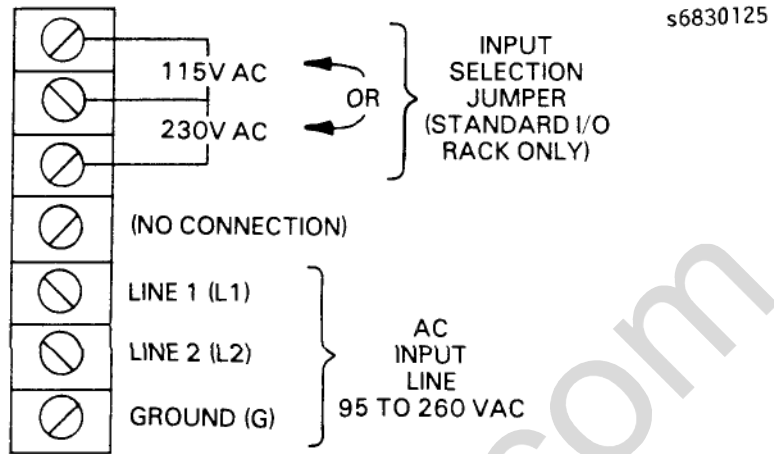

Figure 3. I/O RACK FRONT-PANEL TERMINAL BLOCK

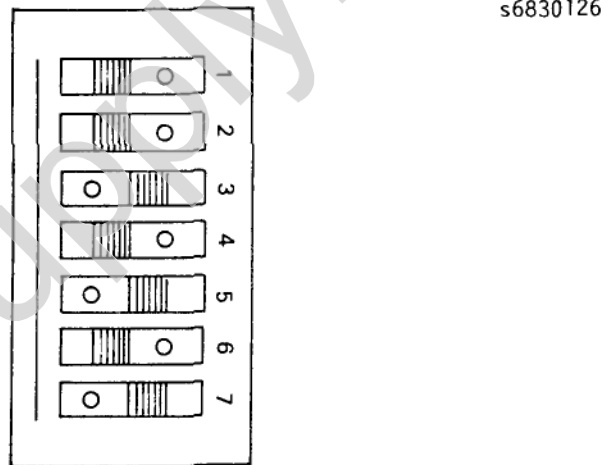
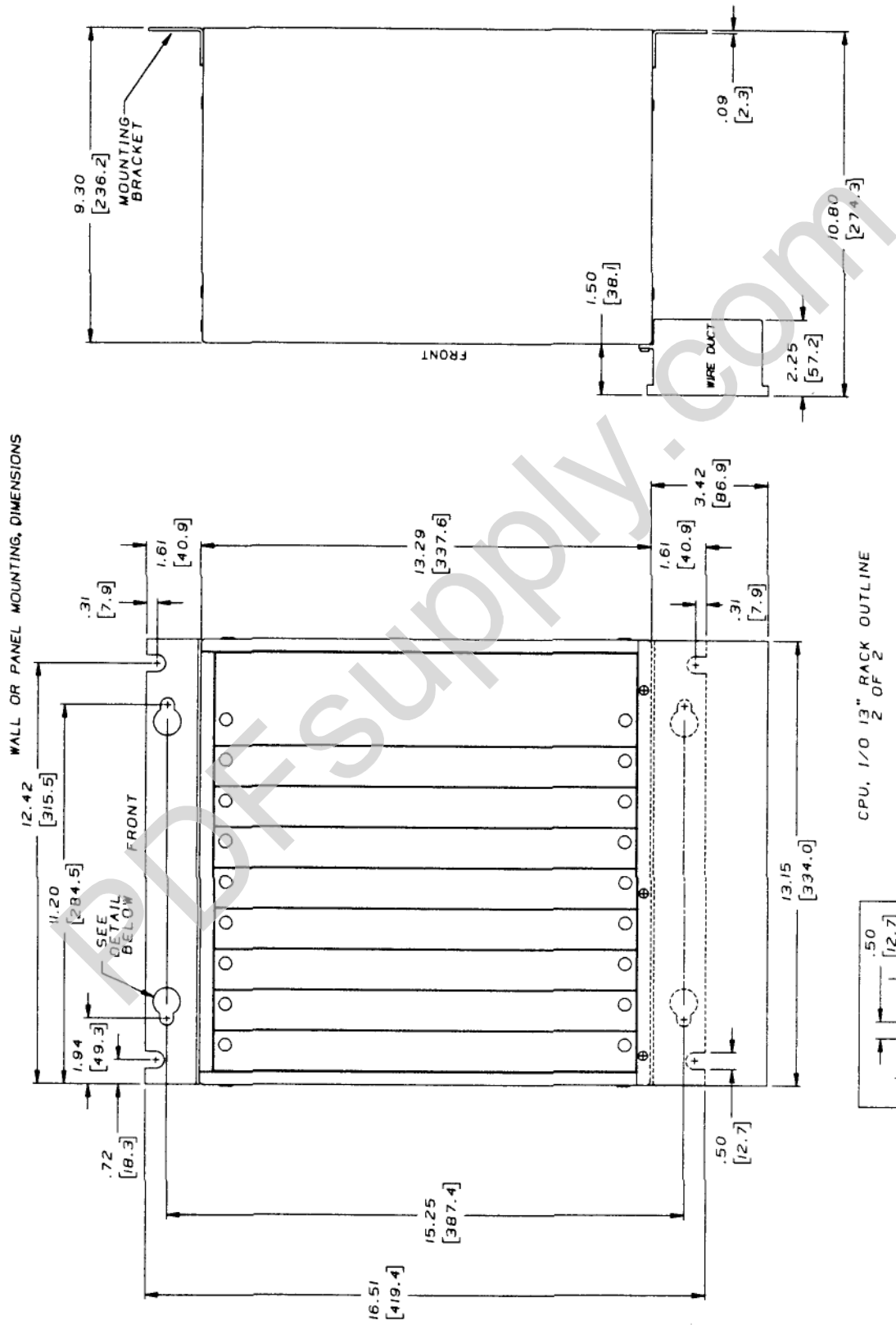
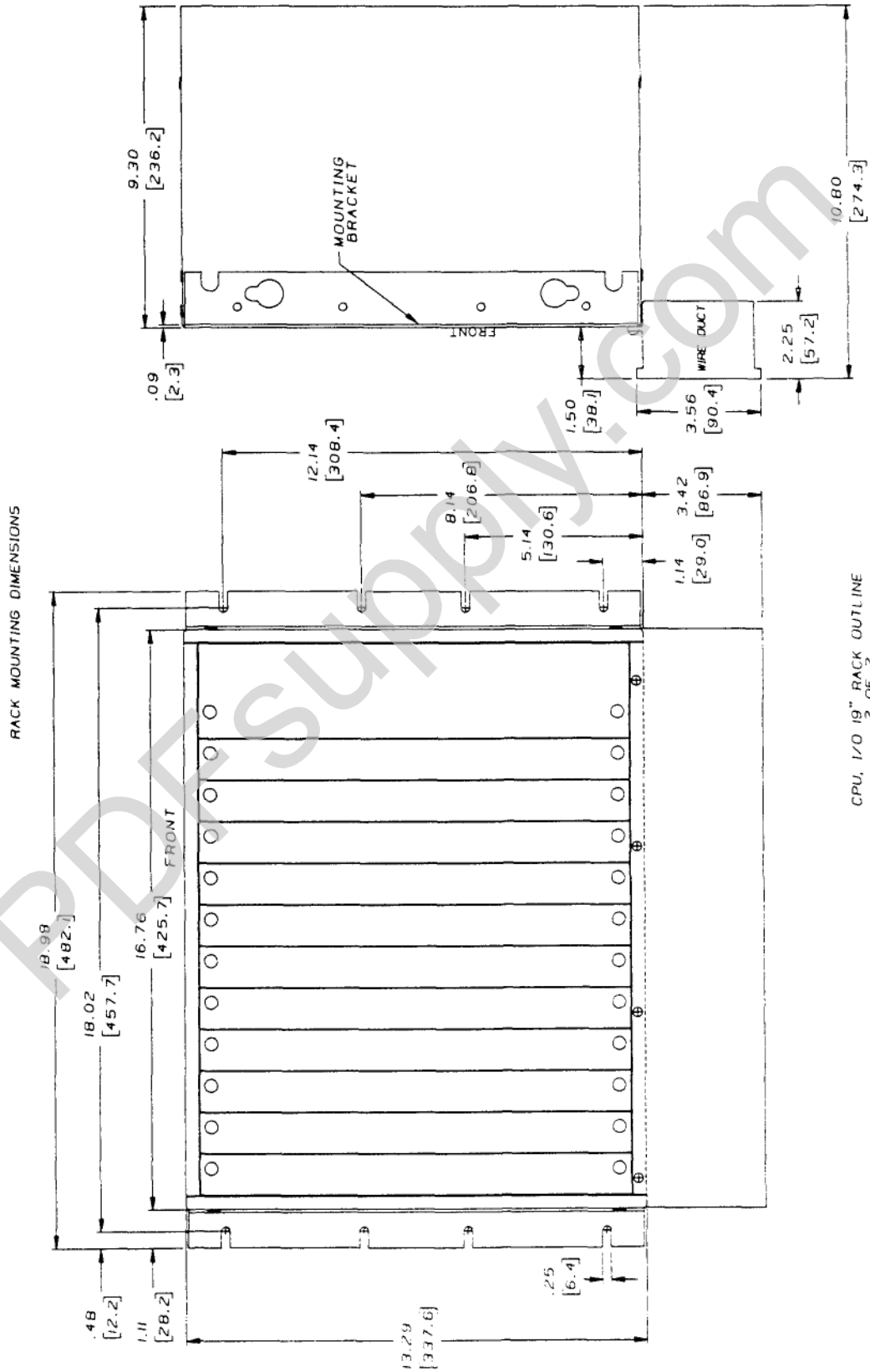

Figure 4. DIP SWITCH

a43011



a43009



GFK-0148A

I/O POINT	DIP SWITCH POSITION					I/O POINT	DIP SWITCH POSITION					I/O POINT	DIP SWITCH POSITION								
	7	6	5	4	3		2	1	7	6	5		4	3	2	1	7	6	5	4	3
1- 8							337-344	X	X	X			673-680	X	X	X					
9- 16						X	345-352	X	X	X	X		681-688	X	X	X	X				X
17- 24					X		353-360	X	X	X			689-696	X	X	X	X				X
25- 32					X	X	361-368	X	X	X	X		697-704	X	X	X	X	X			X
33- 40				X			369-376	X	X	X	X		705-712	X	X	X					
41- 48				X	X		377-384	X	X	X	X	X	713-720	X	X	X					X
49- 56				X	X		385-392	X	X				721-728	X	X	X	X				X
57- 64				X	X	X	393-400	X	X			X	729-736	X	X	X	X	X			X
65- 72				X			401-408	X	X		X		737-744	X	X	X	X				X
73- 80				X		X	409-416	X	X		X	X	745-752	X	X	X	X				X
81- 88				X	X		417-424	X	X	X			753-760	X	X	X	X	X			X
89- 96				X	X	X	425-432	X	X	X	X		761-768	X	X	X	X	X	X		X
97-104				X	X		433-440	X	X	X	X		769-776	X	X						X
105-106				X	X	X	441-448	X	X	X	X	X	777-784	X	X						X
113-120				X	X	X	449-456	X	X	X			785-792	X	X						X
121-128				X	X	X	457-464	X	X	X	X		793-800	X	X						X
129-136				X			465-472	X	X	X	X		801-808	X	X						X
137-144				X		X	473-480	X	X	X	X	X	809-816	X	X						X
145-152				X		X	481-488	X	X	X	X		817-824	X	X						X
153-160				X	X	X	489-496	X	X	X	X	X	825-832	X	X						X
161-168				X	X		497-504	X	X	X	X	X	833-840	X	X	X					X
169-176				X	X	X	505-512	X	X	X	X	X	841-848	X	X	X					X
177-184				X	X	X	513-520	X					849-856	X	X	X					X
185-192				X	X	X	521-528	X				X	857-864	X	X	X	X				X
193-200				X	X		529-536	X			X		865-872	X	X	X	X				X
201-208				X	X		537-544	X			X	X	873-880	X	X	X	X				X
209-216				X	X		545-552	X			X		881-888	X	X	X	X	X			X
217-224				X	X	X	553-560	X			X	X	889-896	X	X	X	X	X			X
225-232				X	X	X	561-568	X			X	X	897-904	X	X	X					X
233-240				X	X	X	569-576	X			X	X	905-912	X	X	X					X
241-248				X	X	X	577-584	X			X		913-920	X	X	X					X
249-256				X	X	X	585-592	X			X		921-928	X	X	X					X
257-264				X			593-600	X			X		929-936	X	X	X	X				X
265-272				X		X	601-608	X			X	X	937-944	X	X	X	X				X
273-280				X		X	609-616	X			X	X	945-952	X	X	X	X				X
281-288				X		X	617-624	X			X	X	953-960	X	X	X	X	X			X
289-296				X		X	625-632	X			X	X	961-968	X	X	X	X				X
297-304				X		X	633-640	X			X	X	969-976	X	X	X	X				X
305-312				X		X	641-648	X			X		977-984	X	X	X	X				X
313-320				X		X	649-656	X			X		985-992	X	X	X	X	X			X
321-328				X		X	657-664	X			X		993-1000	X	X	X	X	X			X
329-336				X		X	665-672	X			X	X									

PC-58-83-0127

X = Switch in OPEN Position (Depressed to the Left).

Figure 5. DIP SWITCH SETTINGS FOR I/O POINT SELECTION FOR EIGHT-CIRCUIT MODULES

Table 2. SUMMARY OF UNITS OF LOAD FOR I/O MODULES

CATALOG NUMBER	MODULE DESCRIPTION	UNITS OF LOAD (1)		
		+5 v	+12 v	-12 v
LC600BF800	I/O Receiver	9		
[C600BF801	Remote I/O Receiver	42	10	10(2)
IC600BF802	24 to 48 V dc Input	2		
IC600BF804	115 V ac/dc Input	2		
[C600BF805	230 V ac/dc Input	2		
IC600BF806	12 V ac/dc Input	2	1	
IC600BF808	Interrupt Input	3		
IC600BF810	115 V ac/dc Isolated Input	2		
IC600BF813	Type 3 Thermocouple Input	29		
IC600BF814	Type K+ thermocouple Input	29		
tC600BF815	Type S Thermocouple Input	29	B	
IC600BF816	Type T Thermocouple Input	29	-	
IC600BF817	Type B Thermocouple Input	29		
tC600BF818	Type E Thermocouple Input	29		
IC600BF819	Type R Thermocouple Input	29		
IC600BF827	High Speed Counter	19		
IC600BF830	Advanced I/O Receiver	12		
IC600BF831	High Density Input	4		
IC600BF841	0 to 10 V dc Analog Input	29		
IC600BF842	+10 V dc Analog Input	29		
IC600BF843	4 to 20 mA analog Input	29		
IC600BF900	I/O Transmitter	34		
IC600BF901	Remote I/O Driver	38	10	10(2)
IC600BF902	24 V dc Sink Output	7		
IC600BF903	48 V dc Sink Output	7		
IC600BF904	115 V ac Output	9		
IC600BF905	230 V ac Output	9		
IC600BF906	12 V dc Sink Output	7		
IC600BF907	12 V dc Source Output	7		
IC600BF908	24 V dc Source Output	7		
IC600BF909	48 V dc Source Output	7		
IC600BF910	115 V ac Isolated Output	8		
IC600BF912	230 V ac Isolated Output	8		
IC600BF914	Reed Relay Output	13		
IC600BF915	Axis Positioning Module, Type 1	42	7	3
IC600BF917	Axis Positioning Module, Type 2	42	11	6
IC600BF921	5 v TTL output	3		
IC600BF923	10 to 50 V dc Sink Output	3		
IC600BF924	120 V dc Output	5	1	
IC600BF929	10 to 50 V dc Source Output	3		
IC600BF930	115 V ac Protected Output	8		
IC600BF941	0 to 10 V dc Analog Output	29		
IC600BF942	+10 V dc Analog Output	29		
IC600BF943	4 to 20 mA Analog Output	29		
IC600BF944	ASCII Basic Module (12 K)	20	12	
IC600BF949	ASCII Basic Module (28 K)	20	12	

GFK-0148A

Table 2. SUMMARY OF UNITS OF LOAD FOR I/O MODULES - Continued

CATALOG NUMBER	MODULE DESCRIPTION	UNITS OF LOAD (1)		
		+5 v	+12 v	-12 v
IC600BF946	Loop Management Module	20	12	
IC600BF947	I/O Link Local	20	12	
IC600BF948	I/O CCM	20	12	
IC600BF950	I/O CCM4	20	12	
IC600AEL000	LAN Interface Controller Board	20	2	1
IC600AEMO 10	LAN Interface Modem Board	17	16	2
IC600CBB902	Genius Bus Controller (with Diagnostics)	20	2	.
IC600CBB 903	Genius Bus Controller (without Diagnostics)	20	2	¶

Table 3. SPECIFICATIONS

Dimensions (19", 11 slots):

Rack-Mount

19.0(W) x 13.4(H) x 9.3(D) inches (483 x 340 x 236 millimeters)

Panel Mount

20.0(W) x 13.4(H) x 9.3(D) inches (508 x 340 x 236 millimeters)

Dimensions (13", 8 slots):

Rack-Mount

16.0(W) x 13.4(H) x 9.3(D) inches 406 x 340 x 236 millimeters)

Panel Mount (Brackets on sides)

16.0(W) x 4(H) x 9.3(D) inches (406 x 340 x 236 millimeters)

Panel Mount (Brackets On Top and bottom, Side by Side Mount)

13.25(W) x 16.15(H) x 9.3(D) inches (340 x 410 x 236 millimeters)

Weight (Empty)

30 pow-ids (15kg)

Power Supply Input

High Capacity: 90-260 Vac
Standard: 95-130 Vac
190-240 Vac
80 VA (maximum)

Noise Immunity

Meets requirements of NEMA ICS2-230 and ANSI C37.90A.

Power Requirements

Three power supplies are available:
1. 95-260 V ac 47-63 Hz 250VA Max.
2. 20-32 V dc 180 watts Max.
3. 100-150 V dc 200 watts Max.

Allowable Power Interruptions

33 ms minimum at 115 Vac line. (AC supply)
10 ms minimum at 20 Vdc (24 Vdc supply)
4 ms minimum at 100 Vdc (125 Vdc supply)

Power-Supply Output

High Capacity: +5 Vdc, 16.5 A max.
+12Vdc, 1.5 A max.
-12 Vdc, 1.0 A max.

Module Capacity

Standard: +5 Vdc, 6.1 A max.
Seven or ten addressable card slots, plus one non-addressable slot for an I/O Receiver or Advanced I/O Receiver module.

Operating Temperature

0° to 60°C (32° to 140°F) (outside of the rack)

Storage Temperature

-20°C to +80°C (-4° to 158°F)

Humidity

5% to 95% (non-condensing)

Table 4. ORDERING INFORMATION

DESCRIPTION	CATALOG NUMBER
8-slot, 90-260 Vac High Capacity	IC600YR550L
8-slot, 24 Vdc	IC600YR554K
8-slot, 125 Vdc	IC600YR555K
8-slot, 115/230 Vac, Standard	IC600YR55 1K
1 1-slot, 90-260 Vac, High Capacity	IC600YR560K
11 -slot, 24 Vdc	IC600YR564K
N-slot, 125 Vdc	IC600YR565K
11-slot, 115/230 Vac, Standard	IC600YR561.K



This symbol on the nameplate means the product is Listed by Underwriters Laboratories Inc. (UL Standard No. 508, Industrial Control Equipment, subsection electronic power Conversion Equipment.)

For ordering information regarding all Series Six Plus PLC products, contact your local GE Fanuc sales office.