

IC670ALG630
New In Stock!
GE Fanuc

<http://www.pdfsupply.com/automation/ge-fanuc/field-control/IC670ALG630>

Field Control
1-919-535-3180

In Stock! Thermocouple, 8 Channel IC670A IC670AL IC670ALG

www.pdfsupply.com

Email: sales@pdfsupply.com

Module Operation

The Thermocouple Input Module accepts eight inputs from thermocouples and converts the input level of each to a digital value. The module supports a variety of thermocouple types, as listed in the Module Specifications section.

Each input can be configured to report data as millivolt or temperature (tenths of degrees Celsius or Fahrenheit) measurements.

When thermocouples are measured, the module can be configured to monitor the thermocouple junction temperature and correct the input value for cold junction.

On command from the module's internal microprocessor, the solid-state, optically-coupled multiplexer circuitry provides the present analog value of a specified input to the analog-to-digital converter. The converter turns the analog voltage into a binary (15 bits plus a sign bit) value representing tenths (1/10) of degrees Celsius or Fahrenheit. The result is read by the module's microprocessor. The microprocessor determines if the input is over or under its configured range, or if an open thermocouple condition exists.

When the module is configured to measure millivolts instead of inputs from thermocouples, the result of the analog-to-digital conversion is a value reported in hundredths (1/100) of millivolts.

A Bus Interface Module handles the exchange of all I/O data for the modules in the I/O Station over the communications bus.

The illustration below represents the main functional operations of the Thermocouple module.

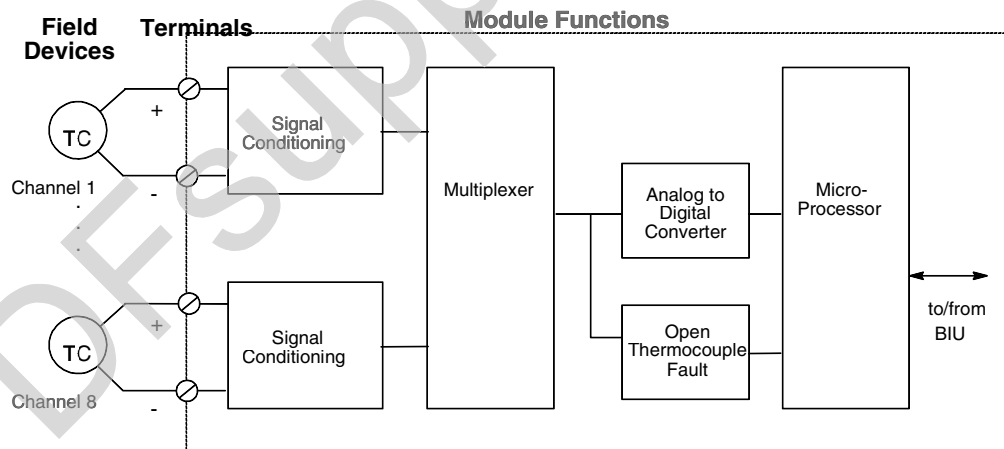

Calibration

The module automatically performs A/D calibration at powerup. Automatic calibration is then repeated every minute to compensate for changes in the ambient temperature. New calibration values are filtered into the current calibration values.

Host Interface

The Thermocouple Input module uses the following data types:

- 8 words of analog input data.
- 8 words of analog output data. This data is written to the module by the Bus Interface Unit (BIU). It contains the Reference Junction Compensation value, which is a 16-bit temperature value in degrees C. Use of this data is optional; it is needed only when Remote Compensation is configured for one or more channels on the module.
- 48 bits of discrete inputs for module and channel status data (use of this data is optional).
- 16 bits of discrete outputs for fault-clearing commands to the module (also optional).

The module exchanges data with a Bus Interface Unit in the same manner as other types of I/O modules—it provides all its input data and status bits when requested by the BIU, and receives fault-clearing commands from the BIU via its assigned output bits. Note that the BIU can be configured not to send status data over the network.

The module can also be configured for “Group” data transfer with the BIU or with other intelligent devices in the same Field Control station. Group data transfer, and the steps for configuring it, are described in the *Bus Interface Unit User's Manual*.

Compatibility

This module must be used with a Bus Interface Unit revision 2.0 or later.

Thermocouple Limits

The table below lists millivolt and temperature limits for applicable thermocouple types.

TC Type	Low mV Limit	High mV Limit	Low Temperature Limit ((C)	High Temperature Limit (C)
J	-8.0960	57.9420	-210.00	1000.00
K	-5.8910	54.8069	-200.00	1370.00
T	-5.6030	20.2520	-200.00	390.00
E	-8.8240	76.3580	-200.00	1000.00
S	-0.1940	18.5040	-40.00	1750.00
R	-0.1880	20.8780	-40.00	1750.00
B	0.03300	13.8140	100.00	1820.00
N	-0.57480	47.5019	-22.222	1300.00
G	-0.00600	38.5639	4.444	2315.55
C	0.23400	37.0660	-17.7777	2315.55
D	-0.16300	39.5060	-17.7777	2315.55
Platinel II	0.0000	52.25	0.00	1300.00

Module Configuration Overview

Like other Field Control modules, the Thermocouple Input module is usually configured from the Bus Interface Unit, using a compatible hand-held programmer. The module will also accept configuration data from the bus when used in a system that supports such configuration. The table below summarizes configuration choices and defaults.

The module will power up with the default configuration settings. These defaults may be changed as appropriate for the application. For configuration instructions, refer to the *Bus Interface Unit User's Manual*.

Module Parameter	Description	Default	Choices
Analog Input Data Length	Word length of the module's analog input data in the BIU's analog input (AI) table.	8	1 to 8
Analog Input Data Reference	Starting offset for the module's analog input data in the BIU's analog input (AI) table.		user selectable
Analog Output Data Length	Word length of the module's optional Reference Compensation data in the BIU's analog output (AQ) table.	8	0 or 8
Analog Output Data Reference	Starting offset for the module's optional Reference Compensation data in the BIU's analog output (AQ) table.		user selectable
Discrete Input Data Length	Bit length of the module's optional status data in the BIU's discrete input (I) data table.	48	0 or 48
Discrete Input Data Reference	Starting offset for the module's optional status data in the BIU's discrete input (I) data table.		user selectable
Discrete Output Data Length	Bit length of the module's optional fault-clearing commands in the BIU's discrete output (Q) table.	16	0 or 16
Discrete Output Data Reference	Starting offset for the module's optional fault-clearing commands in the BIU's discrete output (Q) table.		user selectable
Line Frequency	Specifies the line frequency. The module uses this data to control the sampling rate.	60 Hz	50 Hz, 60 Hz
Suppress Open Thermocouple	Determines whether or not the module will suppress Open Thermocouple diagnostics on the input data.	No	Yes, No
Channel Active	Specifies if the channel should return data and alarms. If a channel is "inactive" space is still allocated for it.	Active	Inactive (off) Active (on)
Engineering Units	Specifies how the module will report input values	Millivolts	Millivolts, 1/10 degrees-C, 1/10 degrees F
Thermocouple Type	The type of thermocouple present on each channel.	None	None, J, K, T, E, S, R, B, N, G, C, D, Platinel II
Range	For millivolt inputs only, the range for each channel in millivolts.	625	19.53, 39.06, 78.125, 156.25, 312.5, 625.
R J Type	Specifies how or whether the channel will perform Cold Junction compensation.	Local	Local, Remote, Fixed, None
Alarm Low	The low alarm limit for the channel, in engineering units.	-200	-32,768 to +32,767
Alarm High	The high alarm limit for the channel, in engineering units.	800	-32,768 to +32,767
Reference Junction Value	Specifies a reference value if Fixed RJ Type has been configured.	0	
Offset	Specifies optional amount to be added to compensated and linearized input value when a Conversion Type in degrees has been configured.	0	

Module Features

Channel Active

Each channel can be configured as either active or inactive. If a channel is inactive, it is still sampled from the A/D. The filtering, scaling, calibration, and alarm checks are omitted for that channel, and a value of 0 is returned to the BIU. The reference parameter for the analog input data returns the byte length and is independent of the number of active channels.

If a channel is active, and the configured analog input data length is not long enough to accommodate the data for a particular channel, the data for that channel is still processed, since the response to a group command may be used to transmit that channel's data to the BIU.

Low Alarm Limit and High Alarm Limit

Each input channel can have a low alarm limit and a high alarm limit. If an input reaches one of its limits, the module reports the actual value and sends the appropriate diagnostic bit in the BIU's discrete input (I) table. Alarms do not stop the process or change the value of the input. Alarm limits can be set anywhere over the dynamic range of the signal. The range for each is -32,768 to +32,767. The high alarm limit must be greater than the low alarm limit. If alarm reporting is not wanted, alarm limits can be set beyond the dynamic range of the signal so they will never be activated.

Cold Junction Compensation

The Thermocouple module provides four methods of Cold Junction Compensation.

- **No Cold Junction Compensation:** This is used for millivolt inputs or if cold junction is maintained at 0 degrees C.
- **Remote Cold Junction Compensation:** With this option, cold junction is measured externally and provided to the module by the BIU, using its %AQ output references. Regardless of which channel or channels use remote compensation, the compensation value must appear in the first analog output entry. This one value is used for all remotely-compensated thermocouples attached to the module. The value is in hundredths of a degree.
- **Fixed Cold Junction Compensation:** This option uses a fixed compensation value which is provided as part of the module configuration.
- **Local Cold Junction Compensation:** The best way to provide local compensation is with a Thermocouple Terminal Block. (IC670CHS004), which has two built-in thermistors. It shields thermocouple connections from module heat.

If local compensation is selected and a Thermocouple Terminal Block is not used, separate thermistors must be installed directly at the I/O Terminal Block, using the Thermistor (+) and Thermistor (-) terminals. The thermistor must be BetaTHERM part # 8.5K3A4 (or equivalent) from BetaTHERM Corp., 910 Turnpike Rd., Shrewsbury MA, 01545 (ph: 508 842-0516, FAX: 508 842-0748) **Note:** If local compensation is selected but a Thermocouple Terminal Block or local thermistors are not used, erroneous temperatures may be reported.

Range Selection

The module can be configured for any of six different millivolt ranges (+/-): 19.5mV, 39mV, 78.125mV, 156.25mV, 312.5mV, and 625mV. All but the last provide input readings in hundredths of millivolts. For the 625mV range, inputs are in tenths of millivolts.

Module Specifications

Module Characteristics	
Number of Channels	8 Each channel is individually configurable.
Thermocouple types	J, K, T, E, S R, B, N, G, C, D, Platinel II
Spans (+/-)	19.5mV, 39mV, 78.125mV, 156.25mV, 312.5mV, 625mV
Converter resolution	15 bits + sign
Cold junction compensation	If used, reference junction temperature either measured at thermocouple termination using a precision thermistor, or supplied by system, or by fixed configuration value.
Cold junction temperature error	+/-0.25 degree Celsius (local measurement). To reduce temperature transients, thermocouple terminations should not be installed in the same cabinet as high heat-dissipation assemblies.
Conformity error	+/-0.3 degree Celsius, +/-0.5 degree Fahrenheit.
Operating temperature range	0 to 55 degrees Celsius ambient.
Accuracy, at 25 deg. C on voltage measurement	+/-0.1% of reading, +/-0.05% of span for J, K, T, and E thermocouple types
Temperature sensitivity (0deg. to 60 deg.C)	+/-0.004% of reading, +/-1.5µV per deg. Celsius referred to input
Normal mode rejection	60dB, at 50/60 Hz, 100% span
Common mode rejection	120 dB at 50/60Hz, 100 ohm imbalance
Common mode voltage	250 Vrms (350 VDC or peak AC)
Maximum voltage between channels	250 VAC
Isolation:	
User input to logic, user input to frame ground.	1500 VAC for 1 minute, 250 VAC continuous.
Channel to Channel	250 VAC continuous.
Current drawn from BIU power supply	195 mA maximum
Normal mode voltage	100% overrange DC or peak AC operational 28 VDC or peak AC maximum
Scan time	60 Hz: approximately 60 milliseconds per point 50 Hz: approximately 70 milliseconds per point.
Fault detection	Open Thermocouple, over/under range, and high/low alarm

Keying Locations

Optional keying locations for the Thermocouple module are:

Keying Locations									
A	B	C	D	E	F	G	H	J	K
x			x				x	x	

Installation Instructions

Thermocouples can be wired directly to the I/O Terminal Block on which the Thermocouple module is installed, or wired to an optional Thermocouple Terminal Block (IC670CHS004).

If a Thermocouple Terminal Block is used, installing the Thermocouple Module itself on an I/O Terminal Block with Wire to Board Connectors provides the simplest connection between terminal blocks. However, the module can be installed on any Field Control I/O Terminal Block. Terminal assignments for each type of Field Control I/O Terminal Block are shown below. Note that if a thermistor is connected locally to the I/O Terminal Block on which the module is installed, to achieve "local" cold junction compensation, the thermistor must be electronically identical to the thermistor in the Thermocouple Terminal Block.

The Terminal Block with box terminals has 25 terminals for each module. Each terminal accommodates one AWG #14 (avg 2.1mm² cross section) to AWG #22 (avg 0.36mm² cross section) wire, or two wires up to AWG #18 (avg. 0.86mm² cross section). When an external jumper is used, wire capacity is reduced from AWG #14 (2.10mm²) to AWG #16 (1.32mm²).

The I/O Terminal Block with barrier terminals has 18 terminals per module. Each terminal can accommodate one or two wires up to AWG #14 (avg 2.1mm² cross section).

The I/O Terminal Block with Connectors has one 20-pin male connector per module.

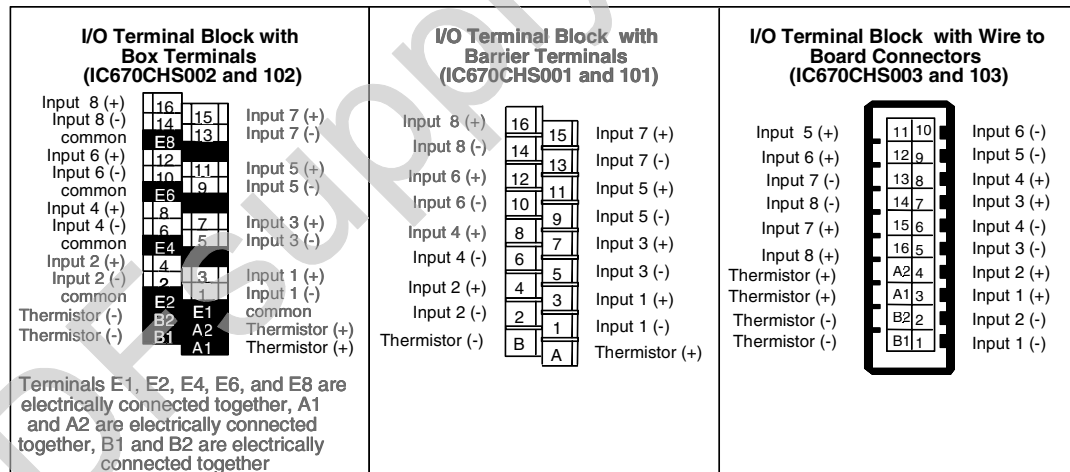

Note: When connecting a thermistor to an I/O terminal block, it is important to be sure that no other connection is made to the thermistor terminals.

Using an Optional Thermocouple Terminal Block

The Thermocouple Terminal Block (IC670CHS004), which has two built-in thermistors, can be used to provide local reference junction compensation. The Thermocouple Terminal Block is installed in the same manner as other Field Control I/O Terminal Blocks.

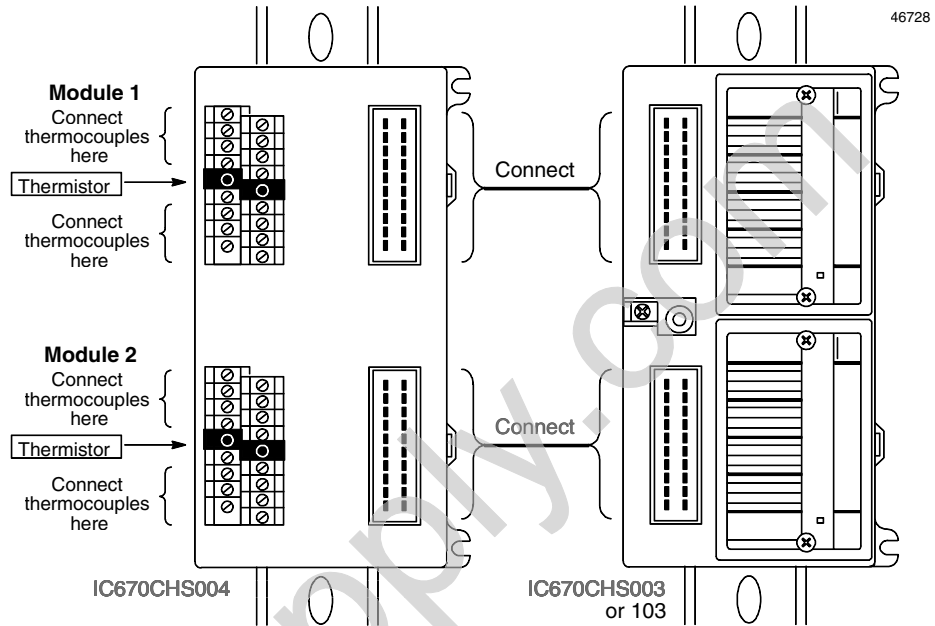

Caution

The Thermocouple Terminal Block must be used with a grounded conductive DIN rail to assure that the assembly screws in the terminal block base cover are connected to chassis ground.

Connecting Thermocouples to a Thermocouple Terminal Block

For each module, the connector pin assignments on terminal block IC670CHS004 with the base mounted in the position shown above are:

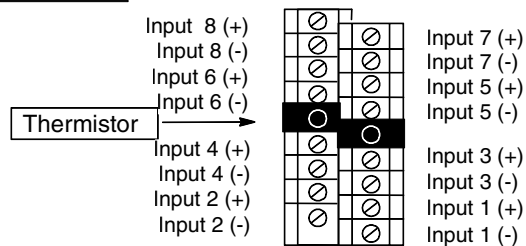

Connecting a Thermocouple Terminal Block to the I/O Terminal Block

Connect a Thermocouple Terminal Block (IC670CHS004) to the I/O Terminal block (IC670CHS003) using an appropriate cable. The diagram below shows the pin assignments for each Wire to Board connector on the Thermocouple Terminal Block (IC670CHS004).

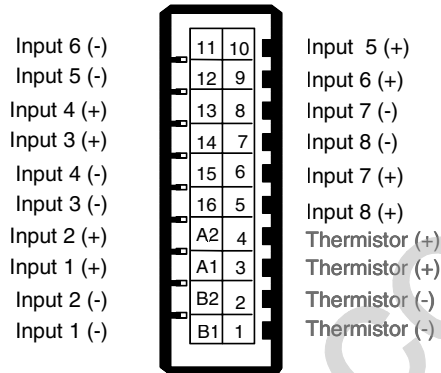
**Using a Crimping Tool**

Pins (catalog number IC670ACC003) must be installed on individual wires using a crimping tool. The AMP™ Pro-Crimper™ II, Hand Tool Assembly 90546-1 is recommended. The tool must be properly adjusted, as detailed in the instructions that come with the tool.

1. Strip the wire 3.96 to 4.75mm (0.156 to 0.187in), taking care not to nick or cut wire strands.
2. Hold the tool with the back (wire side) facing you. Squeeze tool handles together and allow them to open fully.
3. Holding the contact by the mating end, insert the contact-insulation barrel first-through the front of the tool into the appropriate crimp section. Position the contact with the mating end on the locator side of the tool, so that the open "U" of the wire and insulation barrels face the top of the tool. Place the contact up into the nest so that the movable locator drops into the slot in the contact. Butt the front end of the wire barrel against the movable locator.

NOTE: Be sure both sides of the insulation barrel are started evenly into the crimping section. DO NOT attempt to crimp an improperly-positioned contact.

4. Hold the contact in position and squeeze the tool handles together until ratchet engages enough to hold the contact in position. DO NOT deform insulation barrel or wire barrel.
5. Insert stripped wire into contact until it is butted against wire stop as shown.
6. Holding wire in place, squeeze tool handles together until ratchet releases.
7. Check the contact's crimp height as described in the tool instruction sheet. Adjust the crimp height if necessary before continuing.

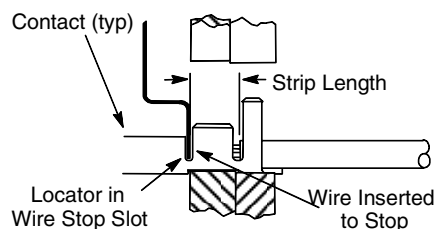

Diagnostics

The Thermocouple module performs diagnostics and provides the diagnostic data to the Bus Interface Unit's discrete input (I) table.

The module sets the appropriate bit when a diagnostic condition is detected. The bit remains set until it is cleared.

Alarm bits are set if the processed value for a channel exceeds its configured alarm limit.

Overrange bits are set if the millivolt value for an input exceeds the limits of its span.

Open circuit is checked every time a thermocouple input is read (unless Open TC checking is disabled). If the circuit is open, the corresponding bit is set, and the input is not processed further.

Circuit Diagnostics Bits (byte 0)

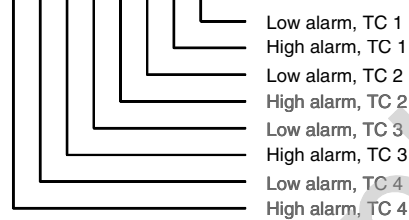
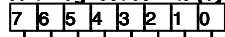

Circuit Diagnostics Bits (byte 1)

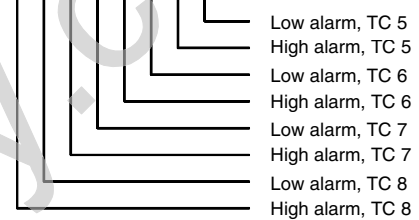

Circuit Diagnostics Bits (byte 2)

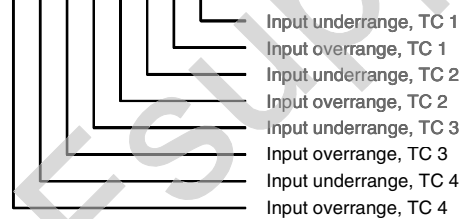
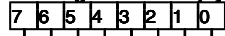

Circuit Diagnostics Bits (byte 3)

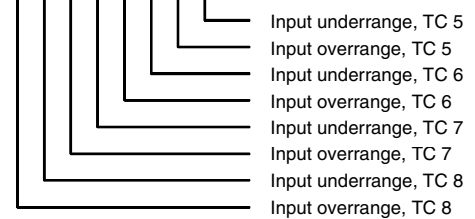
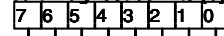

Circuit Diagnostics Bits (byte 4)

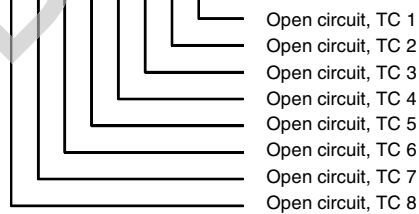
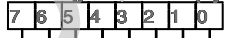

Circuit Diagnostics Bits (byte 5)

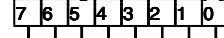

Clearing Faults and Alarms

The host can use a set of 16 discrete output bits in the BIU's discrete output (Q) table to clear and inhibit faults and alarms for the Thermocouple Input module. Setting the appropriate bit from the host clears all diagnostic bits for that thermocouple that may be set.

The discrete input bits for a channel remain clear in the BIU as long as the corresponding discrete output bit is set.

Output Command Bits to Clear Diagnostics (byte 0)

7	6	5	4	3	2	1	0
---	---	---	---	---	---	---	---



Output Command Bits to Clear Diagnostics (byte 1)

7	6	5	4	3	2	1	0
---	---	---	---	---	---	---	---

Clear Errors for Thermistor

A thermistor error occurs if the calculated temperature value from the thermistor is less than -10 degrees C or greater than +75 degrees C.

PDFSupply.com