

GE Fanuc IC694PWR321

<http://www.pdfsupply.com/automation/ge-fanuc/rx3i-pacsystem/IC694PWR321>

Rx3i PacSystem

Power Supply 120/240 VAC 125 VDC Standard IC694P IC694PW
IC694PWR

919-535-3180
sales@pdfsupply.com

Power Supply, 120/240 VAC or 125 VDC: IC694PWR321

Power Supply IC694PWR321 is a 30-Watt supply that operates from an input voltage source in the range of 85 VAC to 264 VAC or 100 VDC to 300 VDC.

This power supply provides three outputs:

- +5 VDC output
- Relay +24 VDC output that can be used to power circuits on Output Relay modules
- Isolated +24 VDC. This power is used internally by some modules. It can also be used to power field devices connected to 24 VDC Input modules

Power Supply IC694PWR321 can be used in an Expansion backplane in an RX3i system. The battery backup and serial port functions are not available in Expansion Backplanes.

LEDs

The green PWR LED shows the operating state of the Power Supply. PWR is ON when the Power Supply has a correct source of power and is operating properly. It is OFF when a Power Supply fault occurs or power is not applied.

The green OK LED is steady ON if the PLC is operating properly. It is OFF if a problem is detected by the PLC.

The green RUN LED is ON when the PLC is in Run mode.

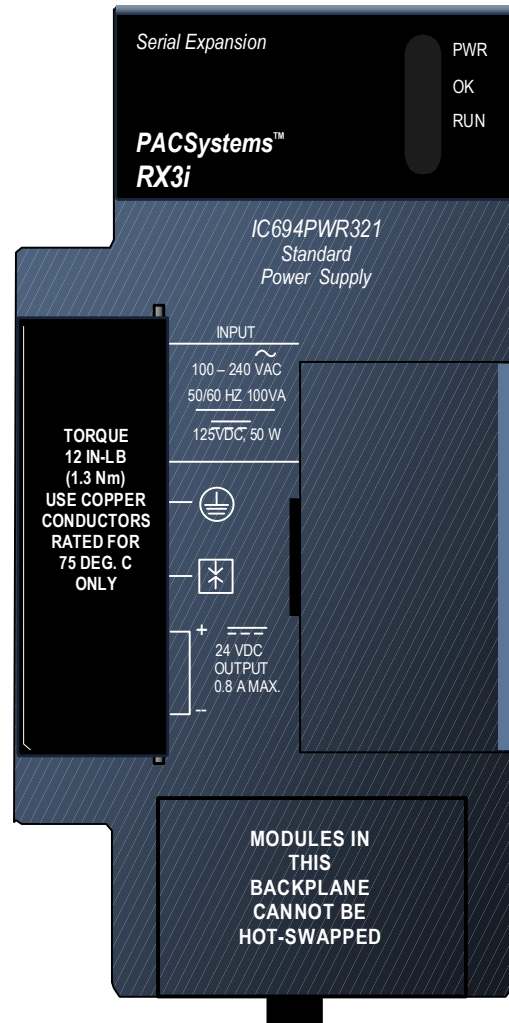

Specifications: IC694PWR321

Nominal Rated Voltage	120/240 VAC or 125 VDC
Input Voltage Range	
AC	85 VDC to 264 VAC
DC	100 VDC to 300 VDC
Input Power (Maximum with Full Load)	90 VA with VAC Input 50 W with VDC Input
Inrush Current	4 Amperes peak, 250 milliseconds maximum
Output Power	5 VDC and 24 VDC Relay: 15 Watts maximum 24 VDC Relay: 15 Watts maximum 24 VDC Isolated: 20 Watts maximum <i>NOTE: 30 Watts maximum total (all three outputs)</i>
Output Voltage	5 VDC: 5.0 VDC to 5.2 VDC (5.1 VDC nominal) Relay 24 VDC: 24 VDC to 28 VDC Isolated 24 VDC: 21.5 VDC to 28 VDC
Isolation (input to backplane):	1500 VAC (for 1 minute)
Protective Limits	
Overvoltage:	5 VDC output: 6.4 VDC to 7 VDC
Overcurrent:	5 VDC output: 4 Amperes maximum
Ride-through Time:	20 milliseconds minimum This is the length of time the Power Supply maintains valid outputs if the power source is interrupted.
Fuse	2 Amps, GE Fanuc part number 44A724627-109 (2). See chapter 2 for more information.

Overcurrent Protection

The 5 VDC output is electronically limited to 3.5 Amps. If an overload (including short circuits) occurs, it is sensed internally and the Power Supply shuts down. The Power Supply continually tries to restart until the overload condition is removed. An internal fuse in the input line is provided as a backup. The Power Supply usually shuts down before the fuse blows. The fuse also protects against internal supply faults.

Warning

The power supply's door must be closed. During normal operation with an AC power source either 120 VAC or 240 VAC is present on the AC Power Supply. The door protects against accidental shock hazard that could cause severe or fatal injury to personnel.

Field Wiring: IC694PWR321

AC Power Source Connections

The Hot, Neutral, and Ground wires from the 120 VAC power source or L1, L2, and Ground wires from the 240 VAC power source connect to the top three terminals on the Power Supply.

DC Power Source Connections

Connect the + and - wires from the 125 VDC power source to the top two terminals. These connections are not polarity-sensitive on Power Supply PWR321.

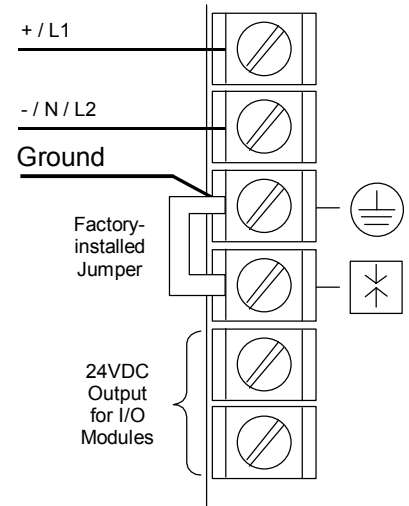

Warning

If the same external DC power source is used to provide power to two or more power supplies in the system, connection polarity must be identical at each power supply. A resulting difference in potential can injure personnel or cause damage to equipment. Also, each backplane must be connected to a common system ground.

The bottom two terminals of the power supply terminal strip provide output connections to the Isolated +24 VDC. This output can be used to provide power for external circuits (within power limitations of the supply).

Caution

If the Isolated 24 VDC supply is overloaded or shorted, the PLC will stop operation.

Input Overvoltage Protection

Terminal 4 is normally connected to frame ground (terminal 3) with a factory-installed jumper strap. If overvoltage protection is not required or is supplied upstream, this feature can be disabled by removing the jumper.

To Hi-pot test this supply, overvoltage protection must be disabled during the test by removing the terminal strip jumper. Re-enable overvoltage protection after testing by reinstalling the strap.

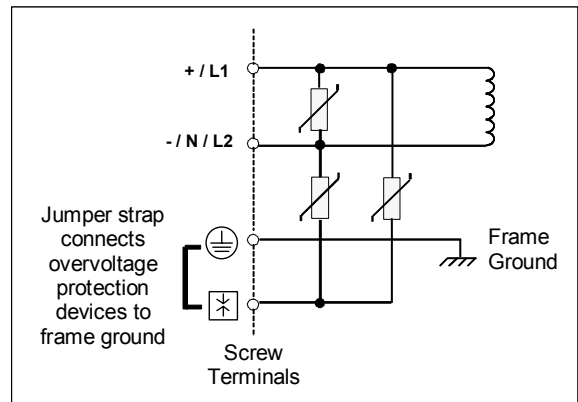

In systems with a floating neutral input (the neutral line is not referenced to Protective Earth Ground), this jumper must NOT be installed. In a floating neutral system, voltage surge protection devices such as MOVs **must** be installed from L1 to earth ground, and from L2 (Neutral) to earth ground