

GE Fanuc IC695CMM002

<http://www.pdfsupply.com/automation/ge-fanuc/rx3i-pacsystem/IC695CMM002>

Rx3i PacSystem

RX3i serial communications module. Two isolated RS-232/485 port.
IC695C IC695CM IC695CMM

919-535-3180
sales@pdfsupply.com

PACSystems™ RX3i

IC695CMM002 and IC695CMM004

Serial Communications Modules

GFK-2461B
August 2007

PACSystems RX3i Serial Communications modules expand the serial communications capabilities of the RX3i system.

Serial Communications module IC695CMM002 provides two independent, isolated serial ports. Serial Communications module IC695CMM004, illustrated at right, provides four independent, isolated serial ports. Up to six Serial Communications modules can be located in the main PACSystems RX3i backplane.

Each port can be configured for MODBUS Master, MODBUS Slave, or Serial I/O protocol. In addition, for modules that are version 1.10 or later, each port can be configured for CCM Slave protocol using Proficy Machine Edition 5.6, SIM 6 or later. For modules that are version 1.20 or later, each port can be configured for DNP3 Master or DNP3 Slave protocol using Machine Edition 5.6 SIM 10 or later. If any port is configured for DNP3 Master or Slave, the other ports on the module can only be configured for DNP3 Master or Slave.

Additional module features include:

- Port-to-port isolation and port-to-backplane isolation
- RS-232, RS-485/422 communication, software-selected
- Hardware handshake: RTS/CTS for RS-232
- Selectable Baud Rates: 1200, 2400, 4800, 9600, 19.2K, 38.4K, 57.6K, 115.2K
- Module fault status reporting (Watchdog, Ram Fail, Flash Fail)
- Module identity and status reporting, including LED status indicators
- Meets CE, UL/CUL 508 and 1604, and ATEX requirements
- Flash memory for future upgrades

These modules must be located in an RX3i Universal Backplane.

RX3i Serial Communications can be hot-inserted and removed following the instructions in the *PACSystems RX3i System Manual*, GFK-2314.

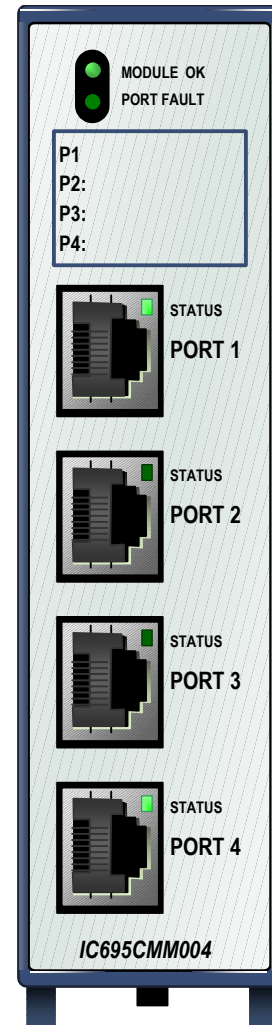

GFK-2461B

Release Information

This release is an upgrade of previous version 1.10.

Release History

Release	Upgrade Kit	Comments
IC695CMM002-AA IC695CMM004-AA	N/A	Initial Release
IC695CMM002-AB IC695CMM004-AB	44A753277-G02 44A753278-G02	Supports CCM Slave Protocol
IC695CMM002-AC IC695CMM004-AC	44A753277-G03 44A753278-G03	Supports DNP3 Master and DNP3 Slave Protocol

New for this Release

This release of the RX3i Serial Module adds support for Distributed Network Protocol 3.0 Master and Slave to the other protocols: MODBUS Master/Slave, CCM, and Serial I/O. This module does not operate with COMMREQs but rather uses preconfigured mappings of the I/O reference memory.

MODBUS Master and MODBUS Slave Protocols now support the configuration of 1 stop bit, for compatibility with some GE Fanuc Automation MODBUS Slaves.

Compatibility

Programmer: Proficy® Machine Edition Logic Developer 5.6 with Service Pack 2 SIM 10

RX3i CPU: PACSystems RX3i CPU Version 5.00 or later is required to be able to use the time synchronization feature on a DNP3 Master port.

Problems Resolved for This Release

When parity is set to none in the port configuration for the Modbus Master or Modbus Slave protocols, the stop bits were forced to 2. This restriction has now been removed and the stop bits can be set to 1 or 2.

Restrictions and Open Issues in this Release

1. When multiple group objects (i.e. %I and %AI memory) are read in a single request, the DNP3 port will ignore all but the first object. Operations of multiple group objects should be split into multiple successive exchanges (i.e. exchange 1 - %I, exchange 2 - %AI).
2. The DNP3 slave port has problems using the link layer to validate frame receipt. The DNP3 organization encourages users not to do this.
3. These modules do not support GE Fanuc special MODBUS commands for use with a Daniels Flow Computer.
4. PLC Reference Address and Reference Length Parameters do not support bit length/start. Bit and Non-Byte Length operations must begin on a byte boundary.
5. When a port is configured for CCM Slave protocol, and:
 - a new configuration is stored to the PLC using Machine Edition, or
 - the system is power-cycled, or
 - the module is hot-inserted,

if the first query received from the CCM Master is a Read Scratchpad request, the module will reject that request. All subsequent Read Scratchpad requests will be successful unless one of the above conditions occurs again.

Operating Notes

The maximum resolution for the MODBUS drop delay is 420us, so the minimum time for a drop delay is 420us.

Installation in Hazardous Locations

- EQUIPMENT LABELED WITH REFERENCE TO CLASS I, GROUPS A, B, C & D, DIV. 2 HAZARDOUS LOCATIONS IS SUITABLE FOR USE IN CLASS I, DIVISION 2, GROUPS A, B, C, D OR NON-HAZARDOUS LOCATIONS ONLY
- WARNING - EXPLOSION HAZARD - SUBSTITUTION OF COMPONENTS MAY IMPAIR SUITABILITY FOR CLASS I, DIVISION 2;
- WARNING - EXPLOSION HAZARD - WHEN IN HAZARDOUS LOCATIONS, TURN OFF POWER BEFORE REPLACING OR WIRING MODULES; AND
- WARNING - EXPLOSION HAZARD - DO NOT CONNECT OR DISCONNECT EQUIPMENT UNLESS POWER HAS BEEN SWITCHED OFF OR THE AREA IS KNOWN TO BE NONHAZARDOUS.

Specifications: IC695CMM002 and IC695CMM004

Refer to the *PACSystems RX3i System Manual*, GFK-2314, for product standards and general specifications.

Number of Serial Ports	IC695CMM002: two independent serial ports IC695CMM004: four independent serial ports	
Connectors	RJ-45	
Number of Serial Communications Modules per CPU	Six in the main CPU backplane	
Backplane power requirements	IC695CMM002	0.7 Amps maximum @ 3.3 VDC 0.115 Amps maximum @ 5.0 VDC
	IC695CMM004	0.7 Amps maximum @ 3.3 VDC 0.150 Amps maximum @ 5.0 VDC
LEDs	Module OK, Port Fault, Port Status (2 or 4)	
Port Type	RS-232 or RS-485/22. 4-wire (full duplex) or 2-wire (half-duplex) operation for RS-485/422	
Flow Control for R-232	Selectable: Hardware (CTS/RTS) or none	
Baud rates	1200, 2400, 4800, 9600, 19.2K, 38.4K, 57.6K, 115.2k	
Parity	Even, odd, none	
Data bits	7, 8	
Stop bits	1, 2	
Operating Temperature	0°C to + 60°C	
Input Impedance	Zin > 96 kOhm for RS-485/422 3 kOhm < Zin < 7 kOhm for RS-232	
Max Overvoltage	+/- 25V	
Channel-Channel Crosstalk	-55dB minimum	
Isolation	Port to Backplane and to frame ground: 250 VAC continuous; 1500 VAC for 1 minute, 2550VDC for one second. Port to port: 500VDC continuous, 710VDC for one minute.	

In order to meet emission and immunity requirements for the EMC directive (CE mark), shielded cable must be used with this module.

LEDs

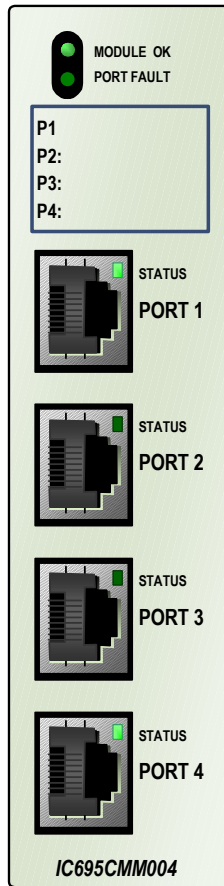

The Module OK LED indicates the status of the module. Solid green indicates that the module has been configured. The Module OK LED is off, if the module is not receiving power from the R3i backplane, or if a serious module fault exists.

At powerup, the Module OK LED flashes green/off while the module is executing powerup diagnostics. It then flashes more slowly as the module receives its configuration from the CPU.

If a problem occurs, the Module OK LED flashes amber. The blink code (see below) indicates the cause of the error.

- 1 = watchdog expired
- 2 = RAM error
- 6 = Invalid CPU Master Interface version
- 7 = CPU heartbeat failure
- 8 = Failed to get semaphore

The Port Fault LED indicates the status of all ports. The Port Fault LED is green when there are no faults present on any enabled port. If this LED turns amber, there is a fault on at least one port.

A port's Status LED flashes green when there is activity on the port.

The area below the module LEDs can be used to record identifying information about each port.

Serial Ports

Each port is a standard RJ-45 female connector with the following pin assignments. For MODBUS applications, note that these pin assignments are different than the standard MODBUS pin assignments. If the port is configured for MODBUS master or slave operation, custom cables are needed.

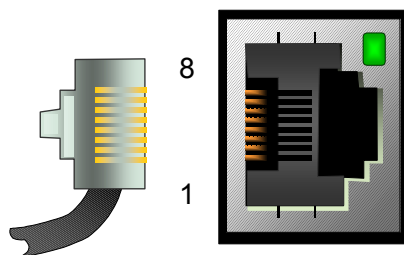

RJ-45 Pin	RS-232	RS-485/422 Half Duplex	RS-485/422 Full Duplex
8	COM	GND	GND
7			Termination 2
6	CTS		R- (RxD0)
5	COM	GND	GND
4		Termination 1	
3	RxD		R+ (RxD1)
2	TxD	T- / R- (D0)	T- (TxD0)
1	RTS	T+ / R+ (D1)	T+ (TxD1)

Note: There is no shield or frame ground pin on the port connector.

GFK-2461B

If the Serial Communications module is communicating with a Series 90-30 CPU363 or external PACSystems RX3i CPU, the connections are:

RX3i Serial Module		CPU363/RX3i
T+	To	RD('B')
T-	To	RD('A')
R+	To	SD('B')
R-	To	SD('A')

Termination

By default, each port is set for no termination. Termination is needed if the module is the first or last device on an RS-485 network, even if there is only one other device on the network. Termination can be provided using either an external resistor as shown below or the port's built-in 120-Ohm termination. If line termination other than 120 Ohms is required, an appropriate external resistor must be supplied.

User-Supplied Termination for RS-485

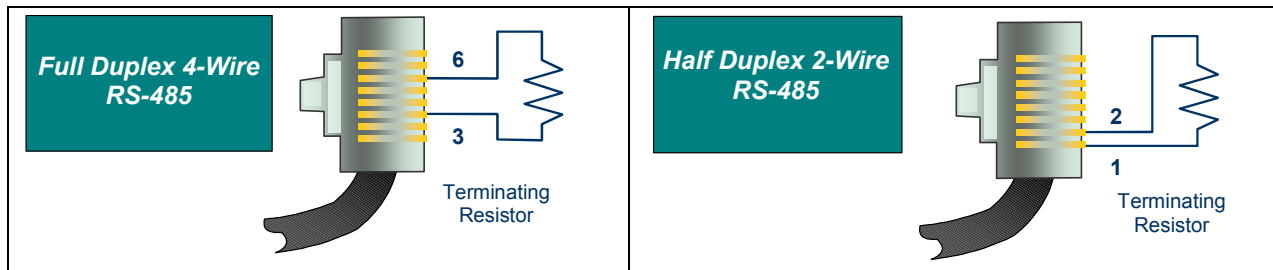

Built-in Termination for RS-485

Termination using the built-in 120-Ohm resistor can be provided by either setting the appropriate RS-485 termination jumper *OR* by installing shorting jumpers on the RS-485 cable connector that attaches to the serial port.

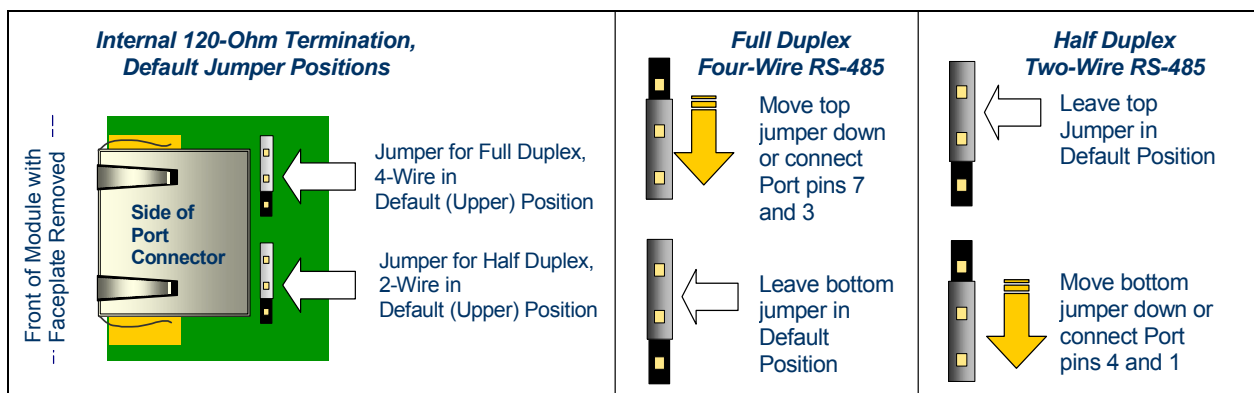

To set 120-Ohm termination internally:

1. Remove the module's faceplate by pressing in on the side tabs and pulling the faceplate away from the module.
2. With the module oriented as shown, move *either* the upper or lower jumper: