

**IC697ALG320**  
**New In Stock!**  
**GE Fanuc**

<http://www.pdfsupply.com/automation/ge-fanuc/series-90-70/IC697ALG320>

**Series 90-70**  
**1-919-535-3180**

In Stock! Analog Output 4PT IC697A IC697AL IC697ALG

[www.pdfsupply.com](http://www.pdfsupply.com)

**Email:** [sales@pdfsupply.com](mailto:sales@pdfsupply.com)



**Channel-to-Channel Compliance**

While it is expected that output loads will be floating or tied to the same potential (normally ground), the module is designed to allow up to 0.5 VDC compliance voltage (labeled  $V_C$  in the previous illustration) difference between outputs and still operate within specifications. This prevents ground loop currents or errors from occurring due to small differences in ground potential at different locations. Note that in addition to this offset, outputs will operate properly in the presence of a large amount of high frequency noise (refer to specifications).

As shown in the previous illustration, the output circuitry is isolated from the PLC backplane. This allows the module to operate within specifications with a common mode voltage of up to  $\zeta$  60V from ground (shown as  $V_{CM}$  in the illustration). It must be observed, however that the entire output section of the module (all four channels) operates at a *singleoffset* voltage from ground potential. Common mode voltage *between* outputs must be within the specifications stated in the previous paragraph.

**User Power for Current Loops**

This module will accommodate a wide range of load impedance; up to 800 ohms. The range of allowable power supply voltage for a given load impedance is shown in Figure 3. For example, a 24V  $\zeta$  20% supply (19.2 to 28.8 volts) will provide sufficient power with loads from 200 to 550 ohms.

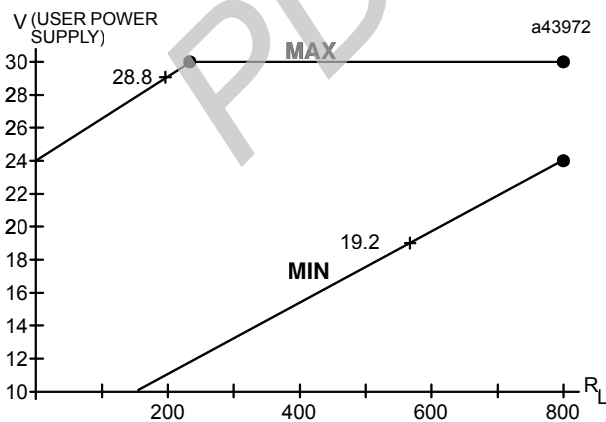

Figure 3. User Power vs. Load Impedance

**User Wiring Connections**

Figure 4 shows the wiring assignments for the screw terminals on the terminal board on the Analog Output module. In addition to the information in this data sheet, circuit wiring diagrams are printed on the inside surface of the label inserted in the module's hinged door.

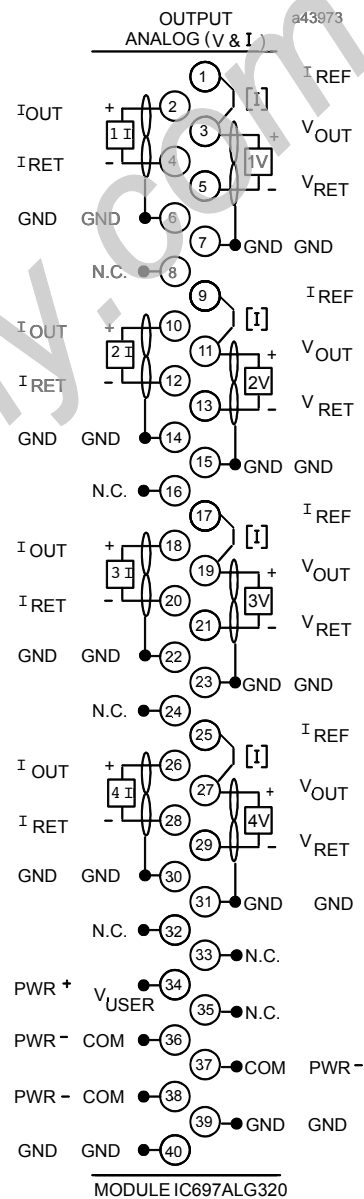

Figure 4. Field Wiring Connections to Module's I/O Terminal Board

GFK-0388G  
August 1997

## High Level Analog Output System - Voltage/Current Module

### Connections to User Devices

Connections to the Analog Output module from user devices are made to screw terminals on a removable 40-terminal connector block mounted on the front of the module. All field connections to the outputs should be wired to the I/O terminal board using a good grade of twisted, shielded instrumentation cable. Separate connections are provided on the terminal board for both current outputs and voltage outputs for each channel. Actual terminals used are determined by the configuration that has been selected for each individual channel.

Ground connections for each channel, labeled GND, on the terminal board are provided for connecting

shields. This ground connection is made directly to the rack, resulting in superior rejection of noise caused by any shield drain currents. Actual selection of ground location may be influenced by system power and ground considerations. However, best operation will be obtained when system ground is physically close to the rack containing the analog circuits. Normally, the shield is grounded at only one end (see Figure 5).

*For additional system grounding information refer to the discussion on system grounding in chapter 3 of the Programmable Controller Installation Manual.*

The module provides electrical isolation of externally generated noise between the output field wiring and the backplane through use of optical isolation.

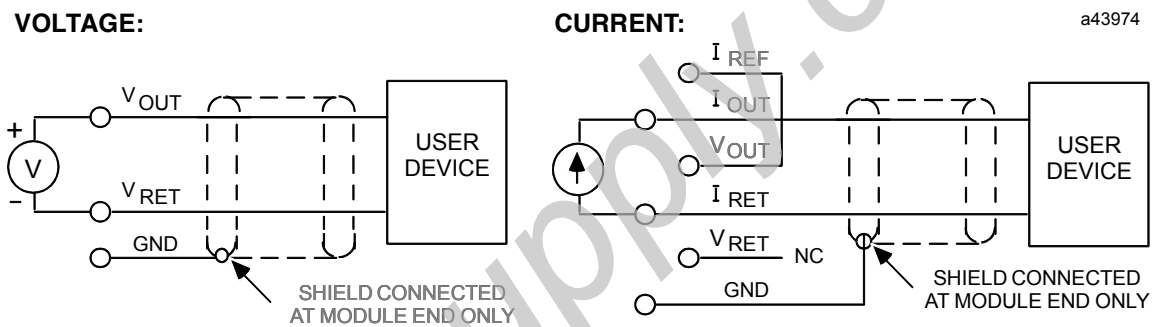

Figure 5. Cable Connections to Field Devices

## Recommended Field Wiring Procedures

The following procedures are recommended when connecting field wiring to the detachable terminal

board on the Analog Output module. Module features referenced in the following procedures which are common to all IC697 I/O modules are illustrated in the following figure.

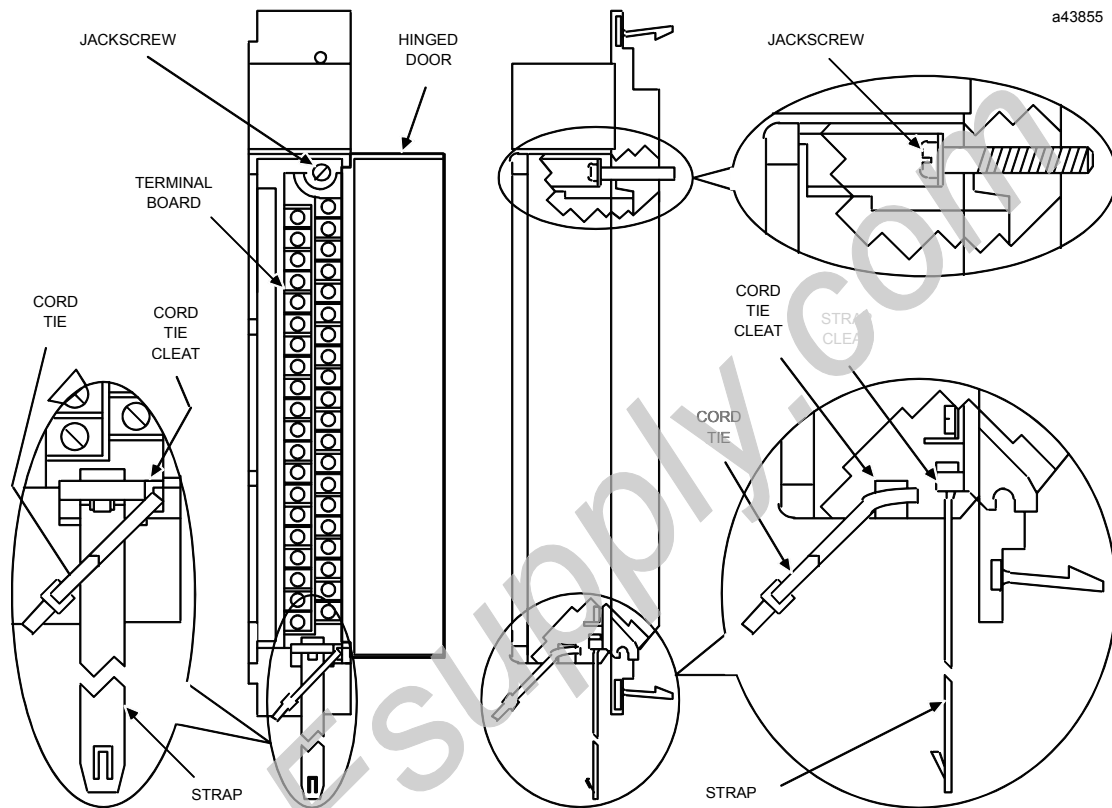

Figure 6. I/O Module Common Features

1. Turn off power before removing or installing terminal boards. Open the hinged door on the module to access a jackscrew which holds the terminal board securely in place. The Detachable field wiring terminal board can now be removed from the module by turning the jackscrew counter-clockwise until it is fully disengaged.
2. To remove the terminal board, grasp the top of the terminal board and swing it outward.
3. The terminal board is designed to accept wire sizes from AWG #22 (0.36 mm<sup>2</sup>) through AWG #14 (2.10 mm<sup>2</sup>). It is important that when using AWG #14 (2.10 mm<sup>2</sup>) wire for wiring all points, that a maximum insulation diameter of .135 inch (3.43 mm) not be exceeded. To ensure proper connection, two wires may be terminated on any one terminal only if both wires are the same size.
4. The terminal board is designed to accept a maximum of (40) AWG #14 (2.10 mm<sup>2</sup>) wires. If AWG #14 (2.10 mm<sup>2</sup>) wires are to be used, then wire markers should be placed at least 8 inches (203 mm) from termination end to provide sufficient space for the hinged door to close.

### Caution

Do not use the hinged door to remove the terminal board. The hinged door could be damaged if this is done.

GFK-0388G  
August 1997

## High Level Analog Output System - Voltage/Current Module

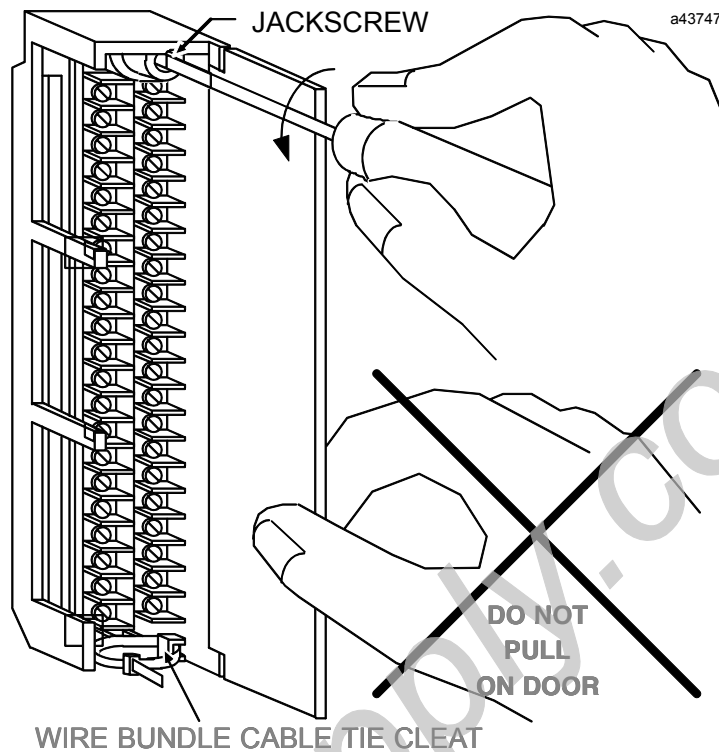

Figure 7. Removal of I/O Terminal Board

5. After completing connections to all modules in a rack, the wire bundle must be secured. To ensure that the wire bundle is secured properly, it is recommended that a cable tie be wrapped around the wire bundle and tightly secured through the cable tie cleat located at the lower right corner of the terminal board. For extremely large wire bundles, additional cable ties should be used.
6. A door label insert is included with each module to indicate circuit wiring information and provide space to record user circuit wiring identification. A slot is provided on the hinged door to allow for insertion of this label. If the label is difficult to insert, crease the scored edge before insertion. The outside label has a color coded stripe to allow quick identification of the module voltage type (*blue*: low voltage; *red*: high voltage).
7. After field wiring is completed, the terminal board should be securely fastened to the rack by inserting the terminal board strap (attached to each module) into the small rectangular slots in the bottom card guide grill on the rack. This strap not

only secures the terminal board to the rack, it also provides a way of identifying the wired terminal board with its correct mating rack slot location.

8. For adequate module ventilation, it is recommended that at least a 5 inch (127 mm) clearance be allowed above and below the rack grill. Wire bundles should not obstruct the rack grill work.

### Removing an I/O Module

The instructions below should be followed when removing an I/O module from its slot in a rack.

- Grasp the board firmly at the top and bottom of the board cover with your thumbs on the front of the cover and your fingers on the plastic clips on the back of the cover.
- Squeeze the rack clips on the back of the cover with your fingers to disengage the clip from the rack rail and pull the board firmly to remove it from the backplane connector.
- Slide the board along the card guide and remove it from the rack.

## Module/Rack Configuration

A high level analog output system for the programmable controller can consist of multiple Analog Output modules providing up to a maximum of 252 output channels.

A maximum of seven Analog Output modules can be installed in a CPU rack, and a maximum of eight Analog Output modules can be installed in an expansion rack.

Channel numbers for each Analog Output module in a system are assigned by the system.

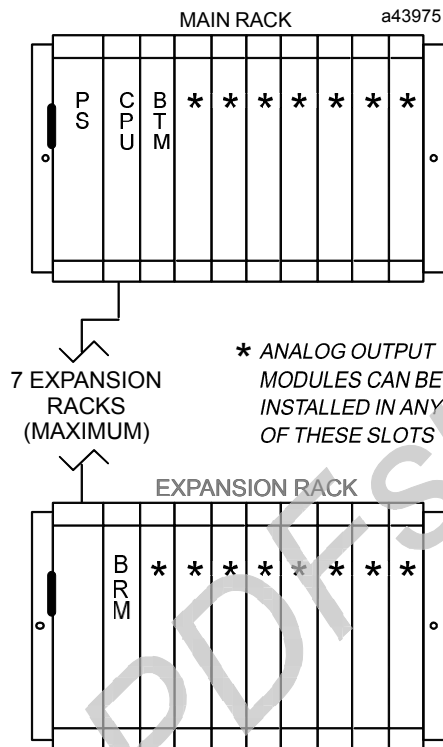

Figure 8. Example of Analog Output Module Installation

## Module Mechanical Keying

Each module includes a mechanical key that prevents inadvertent substitution of one module type for another in a given slot. The key fits a uniquely shaped area on the board below the connector.

When the module is first installed, the key latches onto the backplane center rail. When the module is extracted, the key remains in the center rail, thereby

configuring the slot to accept only identical module types.

If it is necessary to change the module location in the rack after the key has been latched onto the center rail of the rack, the key can be removed by pushing it upward to unhook the latch while pushing it off the rail. It may then be reinserted into the rack at the desired location.

Note that in an IC697CHS PLC rack only the power supply can be placed in the leftmost slot in the rack, and slot 1 (adjacent to the power supply) must always contain a CPU (in rack 0 - the CPU rack), or a Bus Receiver Module or Remote I/O Scanner (in expansion racks).

## Configurable Functions

You can configure certain functions through the MS-DOS or Windows software configurator function using the programming computer. These functions include output ranges, user scaling, and fault reporting. Each of these functions and their definitions are listed in Table 1.

## Module Configuration Data

After the CPU has been updated, the Analog Output module is ready for configuration data. The CPU provides the following module configuration data

- The output circuit type (voltage or current) for each output channel
- CPU fault reporting interrupt, whether enabled or disabled on a per channel
- The default value for outputs and whether outputs are enabled or disabled on system failure or CPU command

Each of the output channel values is checked for over-range, underrange, and open wire; open wire only if configured for current range.

### Note

For more detailed information on using the configuration function, refer to the *Programming Software User's Manual*.

High Level Analog Output System - Voltage/Current Module

Table 1. Configurable features for IC697ALG320

Feature	Channel or Module	Selections	Default Setting
Voltage/Current	Channel	-10V, +10V 0V, +10V -5V, +5V 0V, +5V 4, 20 mA	-10V, +10V
Report Faults	Channel	Enabled/Disabled	Enabled
Scaling Points	Channel		
User Value		Ç 32767 µA	+20000, -4000 µA
mV or mA		Ç 10000 mV	+10000 mV, -10000 mV
Output Default	Channel	Hold/Off	Off
Default Value	Channel	Ç 32767	0

**Output Ranges**

For each output circuit, the range selected during configuration should match the signal. The 4 to 20 milliamp range can be used for current output devices. For current loop operation, the terminal board jumper for each applicable channel must be installed (refer to Figure 4, Field Wiring Connections to I/O Terminal Board).

**Output Default**

Output Default mode is activated when the CPU output data is not being received, such as during power-up, when the CPU is stopped, or CPU communications have been lost. When this occurs, each channel

can be configured to *Hold Last State* or default to a configured *Default Value*. If configured to *Hold Last State*, the channel will maintain the last output value received from the CPU until communications resume. If *Output Default* is configured to OFF, the configured *Default Value* is applied.

Note that the data available to the outputs will be different according to where the system is in relation to time (starting at power-up). This time vs. output data relationship is shown below (Figure 9).

**Default Value**

If the Output Default is set to OFF, this value, programmed in Engineering Units, is applied to the output until communications are restored.

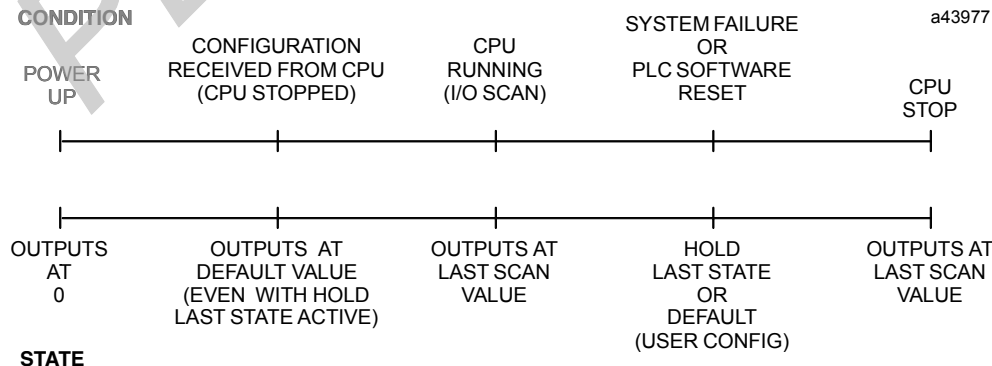

Figure 9. Time vs. Output Data Relationship

## User Scaling

User scaling is definable on a per circuit basis on the Analog Output module. The scaling feature allows the user to convert the value in engineering units into millivolts or milliamps as required by the output device being controlled. Engineering units provide measurement that relates to the application, such as, pressure (psi), speed (feet per second), or temperature (degrees F, C, or K). The default configuration for channels configured for voltage, as shown in Figure 10, provides values of  $-32000$  to  $+32000$  corresponding to a voltage output range of  $-10$  to  $+10$  volts. If a channel is configured for current, default scaling is  $0$  to  $32000$  for a current range of  $4$  to  $20$  mA (see Figure 11).

Scaling can be configured by the user on a per channel basis with the MS-DOS or Windows programming

software configurator function. Scaling is set by entering the desired voltage or current value and the corresponding engineering units for each of two points. Engineering units are a 16-bit signed value ( $-32767$  to  $+32767$ ). When configuring scale factors,  $0$  mV or  $0$  mA must correspond to an engineering unit number between  $+32767$  and  $-32767$ .

### Note

Scaling to engineering units does not increase the resolution of the value, but does transform it into more convenient units. Scaling can be used to compensate for differences between actual and theoretical values due to inaccuracies encountered in field devices.

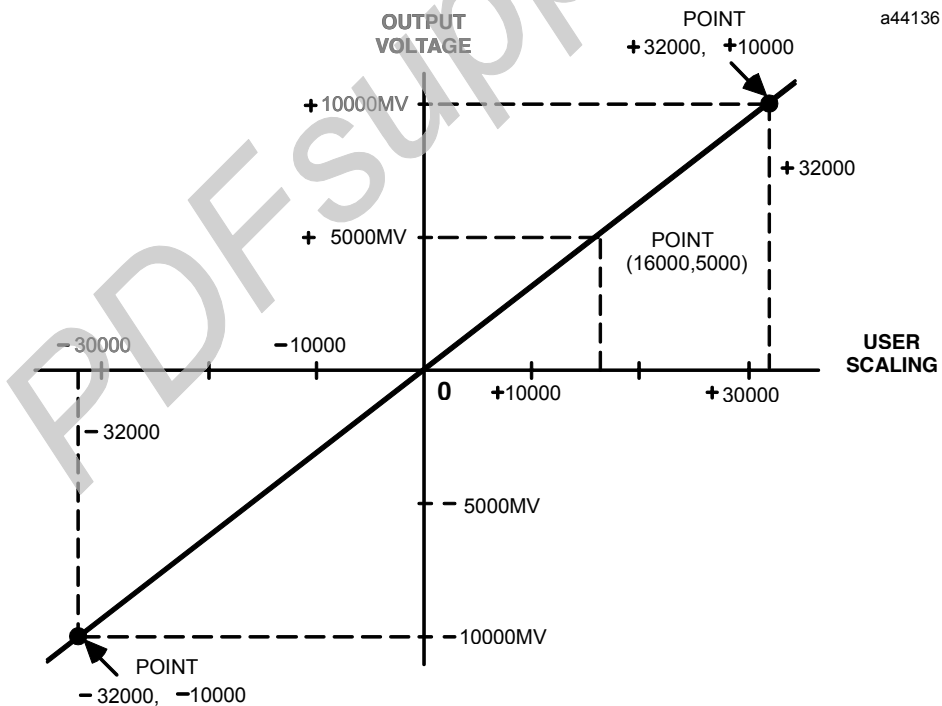

Figure 10. User Scaling for Voltage Output

GFK-0388G  
August 1997

## High Level Analog Output System - Voltage/Current Module

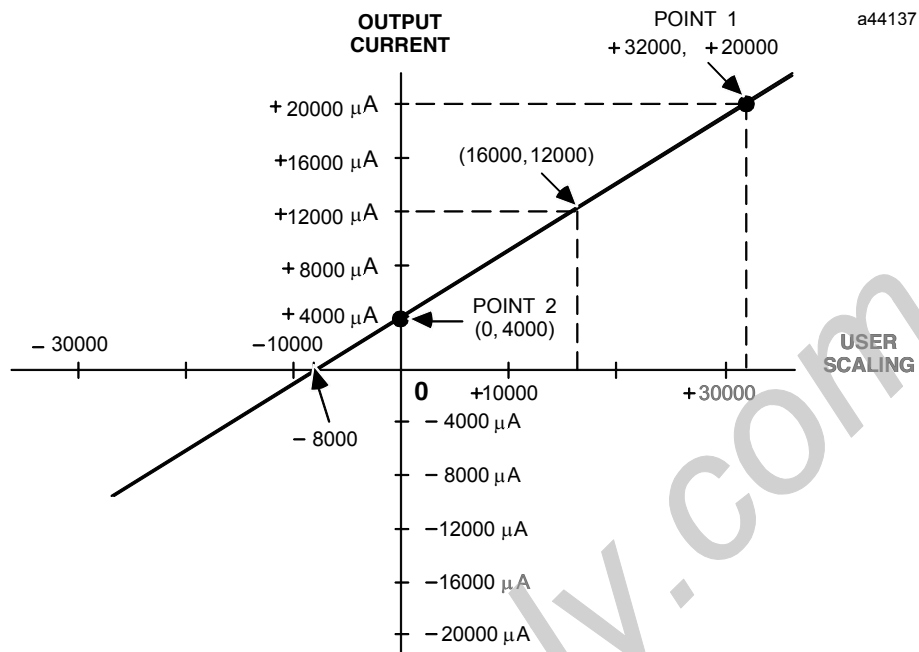

Figure 11. User Scaling for Current Output

### Using Data Commands to Modify Configuration

The Data Command provides a mechanism that allows you to modify some of the diagnostic configuration parameters of the Analog Output Module from ladder logic. The Data Command uses the COMMREQ function block and a small block of parameters to update certain configuration parameters on the fly.

### Sending Data Commands Using the COMMREQ Function

The PLC ladder program sends a Data Command using the COMMREQ (Communication Request) function. The COMMREQ requires that all its command data be placed in the correct order in the CPU

memory before it is executed. It should then be executed by a by a one-shot to prevent sending the data to the module multiple times. Successive COMMREQs must be separated by at least 1 millisecond to guarantee correct processing.

A description of the COMMREQ function and its command block data follows, along with a ladder example which uses registers %R0001 to %R0008 for the COMMREQ command block. Refer to the applicable *Programmable Controller Reference Manual* for additional specific information on COMMREQs.

### COMMREQ Function Block Description

The Communications Request (COMMREQ) function is a conditionally executed function that communicates a particular request, through the ladder logic program, to the Analog module.

### Communications Request Function Block Format

The ladder logic representation of the COMMREQ function block is as follows:

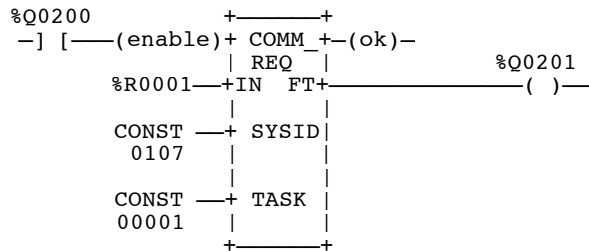

The Communications Request function block has four inputs and two outputs. The first input is an enable input. Generally a one-shot coil is used to enable the COMMREQ function. This prevents multiple messages from being sent. The second input (IN) is the

starting location of the COMMREQ command block. The SYSID input is used to indicate which rack and slot to send the message to (physical location of Analog module). The last input (TASK) is set to the channel number to be configured.

In the above example, channel 1 of rack 1, slot 7 will be configured and the COMMREQ command block starts at Register 0001. Power is always passed to the ok output. The fault output (FT) is enabled if the COMMREQ fails.

### Command Block

The command block for Data Commands is made up of eight words (all values in hexadecimal unless otherwise indicated). Use the block move command to move these values to the Register tables (refer to the applicable *Programmable Controller Reference Manual*, for information on using the block move function).

Table 2. Command Block for Data Commands

Location	Data	Description
%R0001	0002	Length of data is two words
%R0002	0000	Not used (Always zero)
%R0003	0000	Not used
%R0004	0000	Not used
%R0005	0000	Not used
%R0006	0000	Not used
%R0007	nnnn	Data Command - Command Word - Word 0
%R0008	nnnn	Data Command - Command Word - Word 1

### Analog Output Data Command Parameters

The Data Command can be used to change the configuration of Fault Reporting and Output Default values for each channel. Each Data Command reconfigures

both of the parameters for the specified channel using the new data.

Bits in the configuration word are numbered with bit 1 being the least significant bit.

Table 3. Analog Output Data Command Parameters

Location	Description	Data
Command Word 0	Configuration Word	Bit 5: 0 - Default Outputs 1 - Hold Last State Bit 8: 0 - Fault Report Enabled 1 - Fault Report Disabled
Command Word 1	Output Default Value	Range C 32767 Engineering Units



## High Level Analog Output System - Voltage/Current Module

GFK-0388G  
August 1997

```

|
| %Q0200 +-----+
+---] [---+BLKMV+---          /* Move data into registers 8 through 14 */
|         |WORD|
|
| CONST  +---IN1 Q+-%R0008
| 4E20   |      |          /* Register 8 sets the Output Default Value */
|         |      |          /* to 20000 (Hexadecimal 4E20) */
|
| CONST  +---IN2
| 0000   |      |          /* Remaining registers are not used */
|
| CONST  +---IN3
| 0000   |      |
|
| CONST  +---IN4
| 0000   |      |
|
| CONST  +---IN5
| 0000   |      |
|
| CONST  +---IN6
| 0000   |      |
|
| CONST  +---IN7
| 0000   +-----+

          /* Now call the COMMREQ to send the message */

| %Q0200 +-----+
+---] [---+COMM +---
|         |REQ |          /* COMMREQ will set output %T0051 if failure */
|         |   |          /* detected when sending message.      %T0051 */
|
| %R0001 +---IN FT+---      /* Command block data starts in R0001 */
|
|
| CONST  +---SYSID
| 0107   |      |          /* Analog Output Module is in rack 1, slot 7 */
|
| CONST  +---TASK
| 00000001 +-----+      /* Task is set to the channel to be */
|                                     /* configured, in this case channel 1 */

```

GFK-0388G  
August 1997

## High Level Analog Output System - Voltage/Current Module

### Analog Output Diagnostics

Diagnostic capabilities for the analog high level output module include:

- LED on modules for system status indication
- Monitoring the health of the module
- Detection of configuration errors
- Overrange detection
- Underrange detection
- Open wire detection

### Module LED

There is one LED on the Analog Output module. This LED, labeled BOARD OK flashes when the module has powered-up, passed its diagnostic tests, and has configuration data for the CPU. The Board OK LED is turned on if the configurator data from the CPU is OK. It is turned off if there is a configuration error, and a fault is logged in the CPU I/O Fault Table.

### I/O Fault Reporting

The IC697 Analog Output Modules support fault detection which is used to activate fault  $-(\text{FAULT})-$   $-(\text{NOFL T})-$  ladder contacts in the PLC. In addition, a corresponding fault message is logged in the PLC I/O Fault Table, unless fault reporting has been disabled in the channel configuration.

If fault reporting is enabled in the channel configuration, each fault condition is reported once and is not reported again until the fault condition is removed and occurs again.

### Fault Contacts

Any combination of the following faults on a channel will cause the corresponding fault contact to be energized. The IC697 CPU supports one  $-(\text{FAULT})-$  and  $-(\text{NOFL T})-$  contact pair per output channel. Use of fault contacts requires that *Point Faults* be enabled in the CPU, as described in the applicable *Programmable Controller Reference Manual*.

### Overrange

Output Overrange occurs when the output is driven beyond the maximum actual output voltage or cur-

rent capability of the Analog to Digital converter (approximately 10 volts or 22.5 mA, respectively). When this occurs, the actual output is clamped at 10.2 volts if configured for voltage operation or 22.5 mA if configured for current mode operation. An Overrange fault is reported to the CPU I/O fault table if Fault Reporting is enabled in the module configuration, and the corresponding Fault Contact is energized if Point Faults are enabled in the CPU configuration.

### Underrange

Output Underrange occurs when the output is driven beyond the minimum actual voltage or current capability of the Analog to Digital converter (approximately -10 volts or 0 mA, respectively). When this occurs, the actual output is clamped at -10.2 volts if configured for voltage mode operation, or 0 mA if configured for current mode operation. An Underrange fault is reported to the CPU I/O Fault Table if Fault Reporting is enabled in the module configuration, and the corresponding Fault Contact is energized if Point Faults are enabled in the CPU configuration.

### Open Wire

This diagnostic occurs when a channel is configured for current mode (4–20 mA) operation and the output current drops below 1.5 mA. When this occurs, an Open Wire fault is reported to the CPU I/O Fault Table if Fault Reporting is enabled in the module configuration, and the corresponding Fault Contact is energized if Point Faults are enabled in the CPU configuration.

### Configuration Errors

The following configuration mismatch errors are detected by the Analog Output module and reported to the CPU.

- *User scaling* error (where user scaling offset calculation exceeds 16-bit signed data)
- *Calibration EEPROM* failure (output calibration data is invalid)

**User Scaling Error**

This error occurs when the user's two scaling points connected on a plot of engineering units versus mV or mA do not cross the engineering unit's axis between  $-32767$  and  $+32767$ . In other words,  $0$  mV or  $0$  mA must correspond to an engineering units number be-

tween  $-32767$  and  $+32767$ . If this condition is not met the result is a configuration user scaling error, and a fault is reported to the CPU. The module LED is turned off and the module halts after sending the message to the CPU. The valid limits for user scaling are shown in the following figure.

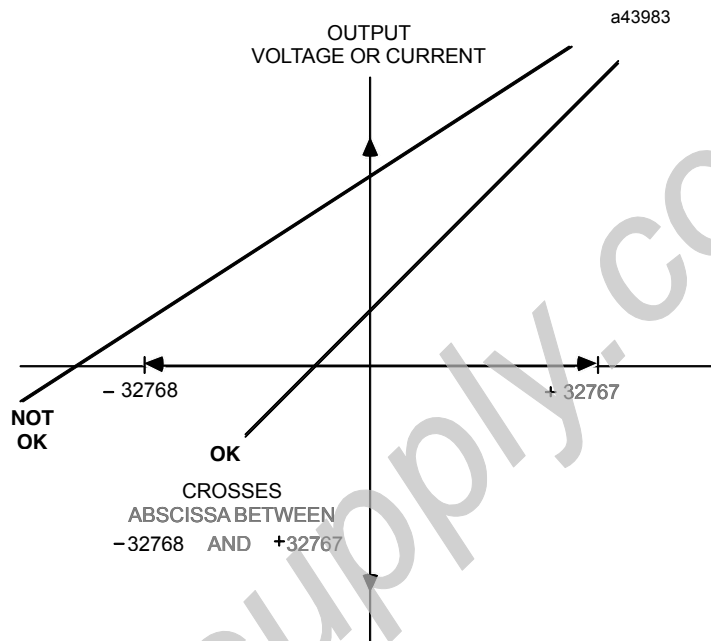

Figure 12. Valid Limits for User Scaling

**Calibration EEPROM Failure**

During the manufacturing process each channel of the Analog Output module is calibrated for accuracy. If the calibration data becomes corrupted, a *Calibration EEPROM* fault is reported to the CPU. The module LED is turned OFF and the module halts after sending the message to the CPU. This failure is not user serviceable. If it should occur, contact the PLC Hotline for help at 1 800 GE FANUC (1 800 433 2682), or International direct dial 804 978 6036.

GFK-0388G  
August 1997

## High Level Analog Output System - Voltage/Current Module

Table 4. Analog Output Specifications †

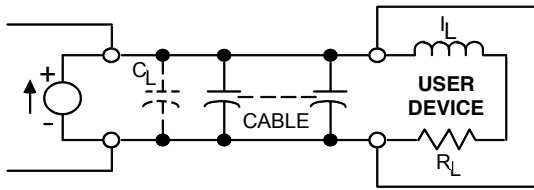
<b>Output Ranges:</b>	Voltage: -10 volts to +10 volts (default) Current: 0.0 mA to 22.5 mA (4 to 20 mA default)
<b>Resolution:</b>	16 bit with 14 bit monotonicity 312.5 microvolts per LSB step on voltage 0.5 microamps per LSB step on 4 to 20 mA No missing codes over 16 bits on voltage. No missing codes over 15 bits on current. NOTE: User scaling may introduce degraded granularity in output voltage depending upon the scaling factors used.
<b>Accuracy:</b> Calibration	Voltage: Factory set at full scale = 10 volts $\pm$ 2.5 millivolts. Current: Factory set at 4.0 mA $\pm$ 5 $\mu$ A and 20 mA $\pm$ 5 $\mu$ A. Full Scale, with 24.0 VDC field side voltage.
Field calibration not possible	Calibrated at factory with calibration data stored in EEPROM memory.
Maximum Errors	at 25 °C (77 °F)
Linearity	$\pm$ 0.02% of full scale over entire negative to positive range.
Temperature Coefficient	Voltage: $\pm$ 25 PPM per °C typical Current: $\pm$ 50 PPM per °C typical
<b>Output Loading:</b> Voltage:	R: minimum = 2000 ohms C: maximum = 1000 picofarads
Current ‡:	R: up to 800 ohms C: maximum = 1.0 microfarad L: maximum = 250 millihenrys
	‡ The current output should be monitored for stability with step changes using inductive loads. There will be combinations of R, L, and C that will not be stable and will require additional capacitance on the current output terminals to maintain output stability with inductive loads (as shown in the following figure). 
<b>Short Circuit:</b>	Voltage and current outputs will handle a continuous short circuit without harm and will return to the proper output (output when short occurred) when the short is removed.
<b>Conversion Rate:</b>	All outputs are updated sequentially approximately every 2.0 milliseconds (maximum) for all 4 channels.

## High Level Analog Output System - Voltage/Current Module

GFK-0388G  
August 1997

Table 4. Analog Output Specifications (continued) †

<b>Response Time:</b> <i>Settling times, to the specified accuracies, for a zero to full scale step output at maximum rated load capacities are:</i> <b>Voltage:</b>  <b>Current:</b>	5.0% 0.5 milliseconds 0.1% 2.0 milliseconds  5.0% 1.0 milliseconds 0.1% 5.0 milliseconds
<b>Output Protection:</b>  <b>Impulse:</b>	Outputs isolated from VME backplane - but not between output channels. They are designed to have a $\leq 0.5$ VDC compliance circuit-to-circuit and operate within specifications. The outputs are protected from overvoltage to the levels listed below.  Outputs normally are not affected by common mode damped ring-wave of up to 1000 volts peak. Common or transverse mode peaks up to 2500 volts cause no damage, but may cause occasional bad data if they occur coincident with conversion of the affected channel. The noise level is a direct function of the grade of cable used for connections.
<b>Power Requirements:</b> <b>Rack Backplane</b> <b>Field Side</b>	+5 VDC at 1.66A (8.3 watts) maximum 150 mA of DC user power must be supplied by the user for the current outputs. The recommended operating voltage is 24 VDC. A range from 10 VDC to 30 VDC (user load impedance dependent, see Figure 3) can be used with some loss in output accuracy.  Field side power to the Analog Output module should be connected to the module with a good quality shielded cable in environments where noise could be coupled into the field side power wiring.

† Refer to GFK-0867B, or later for product standards and general specifications. For installations requiring compliance to more stringent requirements (for example, FCC or European Union Directives), refer to *Installation Requirements for Conformance to Standards*.

Table 5. Ordering Information

Description	Catalog Number
High Level Analog Output Module	IC697ALG320

Note: For Conformal Coat option, or Low Temperature Testing option please consult the factory for price and availability.

PDFsupply.com