

IC697PWR711

New In Stock!

GE Fanuc

<http://www.pdfsupply.com/automation/ge-fanuc/series-90-70/IC697PWR711>

Series 90-70

1-919-535-3180

In Stock! AC/DC Power Supply, 120/240 Vac, 125VDC, 100 Watts
IC697P IC697PW IC697PWR

www.pdfsupply.com

Email: sales@pdfsupply.com

Power Supplies

IC697PWR711/713

GFK-1448B
August 1997

Power Supply Module, 100W, 120/240 VAC or 125 VDC

-This data sheet describes version H (IC697PWR711H/713H), or later versions of this power supply.
-F or a description of version G (IC697PWR711G/713G), and earlier versions - see data sheet GFK-0392G.

Features

- Operation from 120 VAC, 240 VAC, or 125 VDC
- Three output voltages, 100 watts total
 - +5 VDC output up to 20 amps
 - +12 VDC output up to 2 amps
 - 12 VDC output up to 1 amp
- Slide-in rack mount construction
- Electronic short circuit overcurrent protection
- Two rack operation from a single power supply
- Power Factor correction for AC operation
- Jumper for overvoltage protection devices

Functions

The 100 Watt Power Supply Module is a rack-mounted unit that plugs directly into a 48-pin backplane-mounted connector in the leftmost slot in the rack. It provides +5 volt, +12 volt and -12 volt power, and logic level sequencing signals to the backplane.

This power supply may be used either in a single rack application, or may also be used to provide power to a second rack if the total load is within the supply rating. Interconnection to the second rack is through a pre-wired cable (see the ordering instructions on the last page of this data sheet).

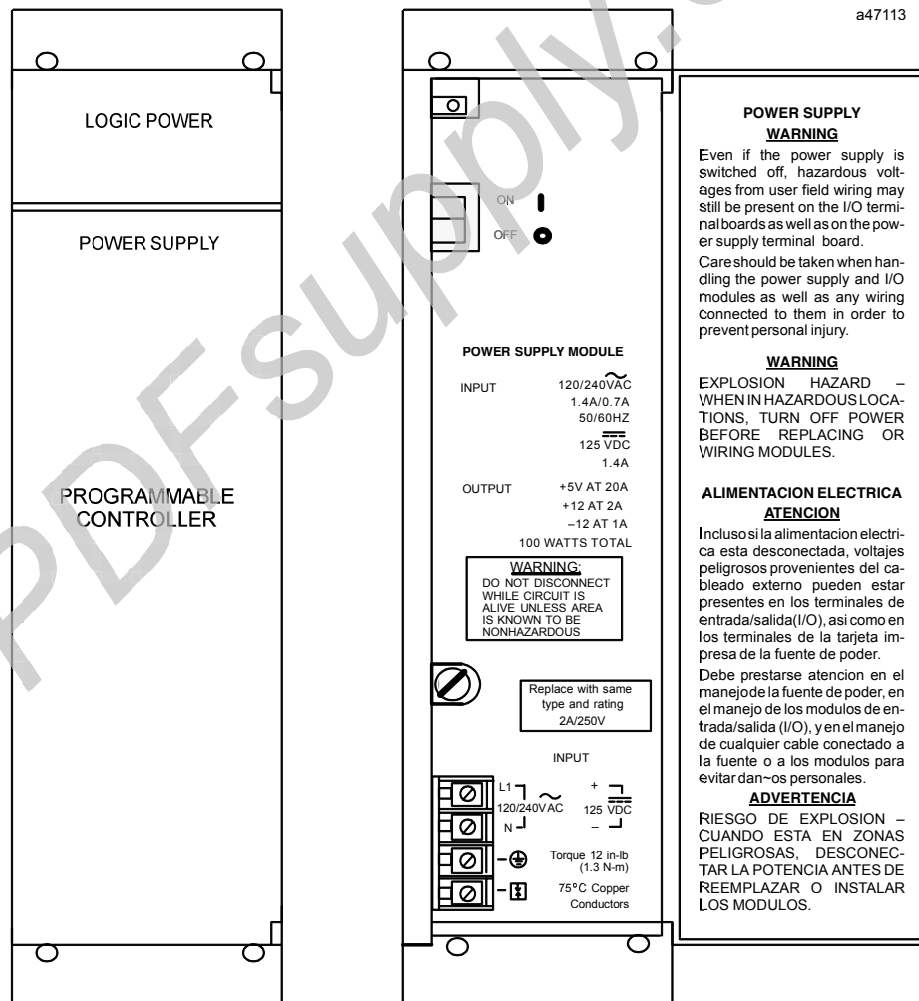

GFK-1448B
August 1997

Power Supply Module, 100W, 120/240 VAC or 125 VDC

The power supply output will ride through at least one input line cycle with a total loss of input power at full load. Protection is provided for overcurrent and over-voltage fault conditions.

Operation of the Power Supply

This Power Supply module can operate from either 120 VAC or 240 VAC nominal inputs. It will also operate from a nominal 125 VDC source. The specified range of operation is from 90 VAC to 264 VAC, and from 100 VDC to 150 VDC.

For continuous operation (greater than one hour) at low line voltages and high temperatures, some power

derating must be applied. Refer to the following figure to determine the normal operating range for specific applications. Normal operating range is shown by the shaded area of the graph for 60°C (140°F) installations. Operation in the non-shaded region for specific applications must be limited to <1 hour. Reducing the maximum operating temperature to 55°C (131°F) will increase the normal operating range as indicated on the graph.

Active power factor correction circuits in this supply maintain a near unity power factor for AC inputs, which eliminates the need for oversized circuit breakers and wiring. This circuitry also limits the half cycle peak inrush currents to a low value.

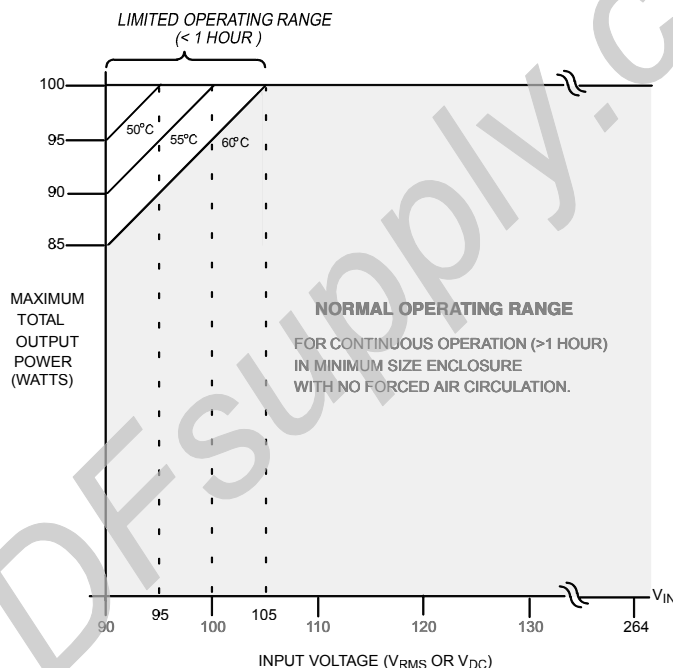

Figure 1. Power Derating for Low Line Voltages

Overvoltage Protection

An electronic shutdown circuit protects against voltages exceeding 6.2 volts. A back-up voltage clamp is provided to protect against sustained overvoltage conditions due to either external influences or internal faults. Overvoltage due to internal faults may cause the fuse to open. For short term overvoltage conditions, normal operation will resume when the cause is removed.

Overcurrent Protection

An electronic current limit is provided on each of the three outputs. An overload on any output will cause the voltage to collapse and may cause the other output voltages to collapse.

Normal operation will resume after removal of the overload. Some component cooling time may be required before normal operation resumes.

Dual Rack Operation

A single power supply can provide power for two racks under the following conditions:

- Only 5 volt power is required in the second rack, and the total power required by both racks is within the capability of the supply.
- The current drawn by the second rack is less than 5.2 amperes.
- The two racks must be mounted in close proximity as limited by the available 3-foot connecting cable.

The connecting cable used for dual rack operation is listed in Table 2, Ordering Information. This cable carries the +5 volts power bus as well as the power sequencing signals. It uses a 9-pin D-type connector which connects directly to the backplane through an opening in the rack frame. Note that the cable carries power and power sequencing signals only. Inter-rack communication and bus interface modules must be provided separately. See the applicable *Programmable Controller Installation Manual* for application information.

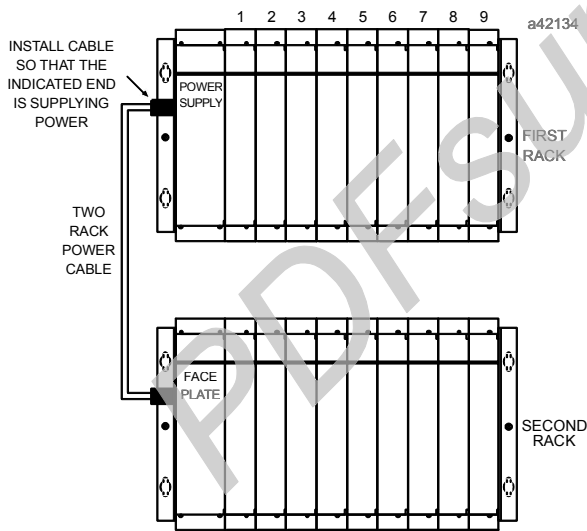

Figure 2. Dual Rack Configuration

Timing Diagram

The timing diagram below shows the relationship of the ac input power to the dc outputs and to the two system signals generated by the power supply: *ACFAIL* and *SYSRESET*.

SET. The 5VSTBY output may be used for user battery backup schemes as shown.

On application of power, the *ACFAIL* signal goes false soon after the 5 volt bus is within specification. The system is held in the Reset state by *SYSRESET* for at least 200 milliseconds after 5 volt power is available (during this time, outputs are forced off).

If AC input power is interrupted, the 5 volt bus will remain within specifications for at least one cycle. The system is then given an additional 5 milliseconds to complete an orderly shutdown before *SYSRESET* stops all processing.

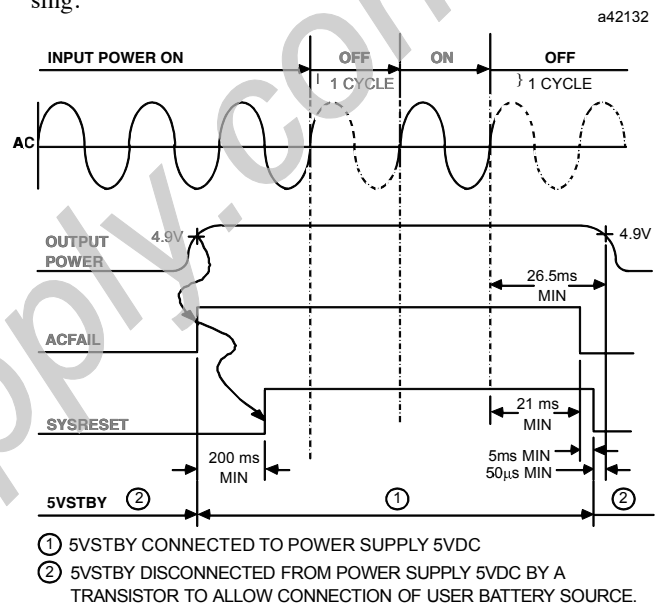

Figure 3. Timing Diagram

Note

Input power interruptions which exceed the power supply holdup time (21 milliseconds minimum) will result in a complete power down/power up cycle of *ACFAIL* and *SYSRESET*.

Mounting

This Power Supply is a plug-in module that is installed in the leftmost slot of any standard IC697 rack or VME Integrator's rack. For additional installation information, refer to GFK-1179, *Installation Guidelines for Conformance to Standards*, shipped with the PLC programming software.

GFK-1448B
August 1997

Power Supply Module, 100W, 120/240 VAC or 125 VDC

Power Supply Door

The power supply door can easily be opened by grasping the upper left corner of the door with your right thumb or a fingernail and gently pulling the door towards you. Use care when opening the door since pulling from the bottom can cause the hinge or the door to break.

Field Wiring Connections

The power input terminal board has four terminals. The top two (L1 and N) are for 120/240 VAC or 125 VDC input power connections; the third and fourth terminals are for ground and overvoltage protection device connections, respectively. Power input connections should be made with copper AWG #16 (1.3 mm²) wire rated for 75°C (167°F). Each terminal can accept solid or stranded wires, but the wires into any given terminal should be the same type and size.

It is recommended that the ground terminal on the power supply be connected to the GND terminal on the rack and to earth using copper AWG #12 (3.3 mm²) wire rated for 75°C (167°F) to ensure adequate grounding. Use of a nut and star washer for each wire on the ground terminal is recommended.

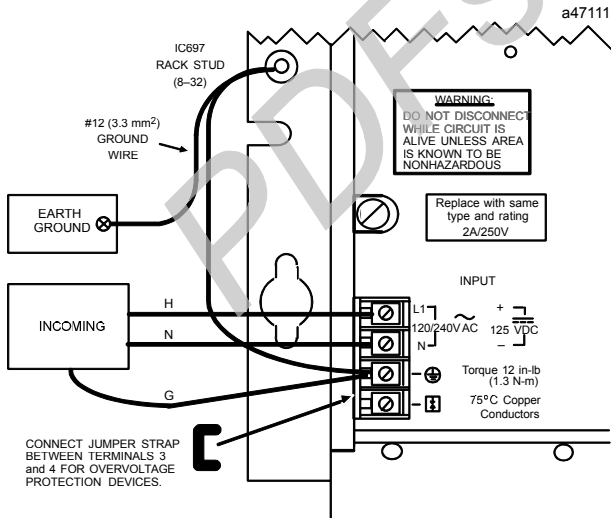

Figure 4. Terminal Board Connections for IC697PWR711/713, Versions H and Later

Overvoltage Protection Devices

The overvoltage protection devices (see Figure 5) for this power supply are connected internally to terminal 4 (bottom terminal) on the input terminal board. This pin is normally connected to frame ground (terminal 3) with the supplied jumper strap which is installed at the factory. If overvoltage protection is not required or is supplied upstream, this feature can be disabled by leaving terminal 4 unconnected by removing the jumper strap.

If you want to Hi-pot test this supply, overvoltage protection **must be disabled** during the test by removing the terminal board strap. Re-enable overvoltage protection after testing by reinstalling the strap.

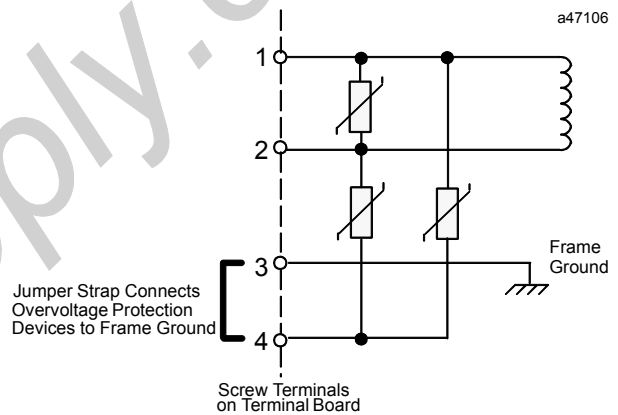

Figure 5. Overvoltage Protection Devices and Jumper

System Noise Immunity

Two easy steps must be taken to properly ground the programmable controller system to reduce the possibility of errors due to electrical noise (see Figure 5).

1. The Ground terminal on the power supply must be connected to the GND terminal on either side of the rack using AWG #12 (3.3 mm²) wire. The Ground terminal should be also be connected to incoming safety ground.
2. The GND terminal on the rack must be connected to a good earth ground.

Power Supply Module, 100W, 120/240 VAC or 125 VDC

GFK-1448B
August 1997Table 1. Specifications FOR IC697PWR711/713
(Version H and Later) †

Nominal Rated Voltage:	120/240 VAC, or 125 VDC
Input Voltage Range: AC Input DC Input	90 to 264 VAC, 47 to 63 Hz 100 to 150 VDC
Input Power: Input Half Cycle Peak Inrush Power Factor	135 watts (typical), 160 watts (maximum) 3 amps (typical) > .93
Output Power: †† Output Voltage:	100 watts maximum (total for all 3 outputs) +5 VDC: 4.90 to 5.25 volts (5.07 volts nominal) +12 VDC: 11.75 to 12.6 volts -12 VDC: -12.6 to -11.75 volts
Protective Limits - Overvoltage Limit: Overcurrent Limit:	+5 VDC Output: 5.7 to 6.7 volts +5 VDC output: 21A (typical) +12 VDC output: 3.5A (typical) -12 VDC output: 1.6A (typical)
Holdup Time:	21 milliseconds minimum (from loss of AC input)
Environmental - Operating Temperature:	0°C to 60°C (32° to 140°F) operating †† -40°C to +85°C (-40° to +185°F) storage

† Refer to data sheet GFK-0867B, or later for product standards and general specifications.

†† Derate for continuous low input voltage, (see Figure 1)

Table 2. Ordering Information

Description	Catalog Number
Power Supply, 120/240 Volts AC, or 125 Volts DC 100 Watts (with jumper for overvoltage protection devices – version H, or later version)	IC697PWR711/713
Power Supply Extension Cable (includes cable and faceplate for empty power supply slot in second rack).	IC697CBL700

Note: For Low Temperature Testing option please consult the factory for price and availability.

GFK-1448B
August 1997

Power Supply Module, 100W, 120/240 VAC or 125 VDC

Special Installation Instructions for Floating Neutral (IT) Systems

When this power supply is installed in a system where the Neutral line is **not** referenced to Protective Earth Ground, these special installation instructions must be followed to prevent damage to the power supply.

Definition of Floating Neutral Systems

As described in this data sheet a *Floating Neutral System* is a system of power distribution wiring where Neutral and Protective Earth Ground are **not** tied together by a negligible impedance. In Europe this is referred to as an IT system (see IEC950). In a *Floating Neutral System*, voltages measured from input terminals to protective earth ground may exceed 264 Volts AC maximum input voltage as specified in the power supply specifications in this data sheet.

Example of Floating Neutral System

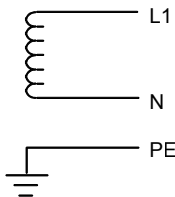

This system **must** be installed using the special installation instructions on this page.

Systems in which one leg of the power distribution wiring is tied to Protective Earth or a tap between two legs of the power distribution wiring is tied to Protective Earth are **not** *Floating Neutral Systems*.

Examples of Non-Floating Neutral System

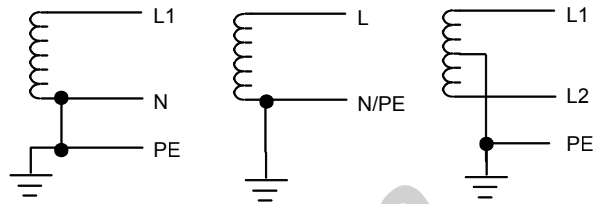

These systems **do not** require these special installation instructions.

Use These Special Installation Instructions for Floating Neutral Systems

1. The input power terminals should be wired according to the instructions in this data sheet.
2. The factory installed jumper between terminals 3 and 4 of the power supply module **must** be removed.
3. Voltage surge protection devices, such as MOVs, **MUST** be installed between the following terminals:

- From L1 to earth ground
- From L2 (Neutral) to earth ground

The voltage surge devices must be rated such that the system is protected from power line transients that exceed $Line\ voltage + 100V + (N-PE)_{MAX}$.

For example, in a 240 Volt AC system with neutral floating 50V above earth ground, the transient protection should be rated at:

$$240V + 100V + 50V = 390V$$

Power Supply Module, 100W, 120/240 VAC or 125 VDC

GFK-1448B
August 1997

The following statements are required to appear for Class I Div 2 Hazardous Locations.

1. EQUIPMENT LABELED WITH REFERENCE TO CLASS I, GROUPS A, B, C, and D, DIV. 2 HAZARDOUS LOCATIONS IS SUITABLE FOR USE IN CLASS I, DIVISION 2, GROUPS A, B, C, D OR NON-HAZARDOUS LOCATIONS ONLY.
2. WARNING - EXPLOSION HAZARD - SUBSTITUTION OF COMPONENTS MAY IMPAIR SUITABILITY FOR CLASS I, DIVISION 2.
3. WARNING - EXPLOSION HAZARD - DO NOT DISCONNECT EQUIPMENT UNLESS POWER HAS BEEN SWITCHED OFF OR THE AREA IS KNOWN TO BE NON-HAZARDOUS.

PDFsupply.com

PDFsupply.com