

120 Volt AC Output - 0.5 Amp, 12 Point IC693MDL310

The *120 volt, 0.5 Amp AC Output* module provides 12 output points in two isolated groups with six points in each group. Each group has a separate common associated with it (the two commons are not tied together inside the module). This allows each group to be used on different phases of the AC supply, or powered from the same supply. Each group is protected with a 3 amp fuse, and an RC snubber is provided for each output to protect against transient electrical noise on the power line. This module provides a high-degree of inrush current (10x the rated current) which makes the outputs suitable for controlling a wide range of inductive and incandescent loads. AC Power to operate loads connected to outputs must be user supplied. This module requires an AC power source.

LED indicators which provide the ON/OFF status of each point are at the top of the module. The LEDs are arranged in two horizontal rows with eight green LEDs in each row and a red LED centered between and to the right of the two rows. This module uses the first six LEDs, labeled A1 through 6 in the top row and the first six LEDs, labeled B1 through 6, in the bottom row, for output status. The red LED (labeled F) functions as a blown fuse indicator that turns ON if any of the fuses should blow. An insert goes between the inside and outside surface of the hinged door. The surface towards the inside of the module (when the hinged door is closed) has circuit wiring information, and circuit identification information can be recorded on the outside surface. The outside left edge of the insert is color-coded red to indicate a high-voltage module. This module can be installed in any I/O slot of a 5 or 10-slot baseplate in a Series 90-30 PLC system.

Although this module is configured as a 16 point output, only outputs 1 through 6 and 9 through 14 are available to be referenced in your program. For example, if the starting reference is Q0017, then valid references are Q17 through Q22 and Q25 through Q30.

Table 7-3. Specifications for IC693MDL310

Rated Voltage	120 volts AC
Output Voltage Range	85 to 132 volts AC, 50/60 Hz
Outputs per Module	12 (two groups of six outputs each)
Isolation	1500 volts between field side and logic side 500 volts between each group
Output Current †	0.5 amp maximum per point 1 amp maximum per group at 60°C (140°F) 2 amps maximum per group at 50°C (122°F)
Output Characteristics	
Inrush Current	5 amps maximum for one cycle
Minimum Load Current	50 mA
Output Voltage Drop	1.5 volts maximum
Output Leakage Current	3 mA maximum at 120 volts AC
On Response Time	1 ms maximum
Off Response Time	1/2 cycle maximum
Power Consumption	210 mA (all outputs on) from 5 volt bus on backplane

† Maximum load current is dependent upon ambient temperature as shown in graph on following page.

Refer to Appendix B for product standards and general specifications.

IC693MDL310 Output Module Field Wiring Information

The following figure provides wiring information for connecting user supplied input devices and power source to the 120 volt AC output module.

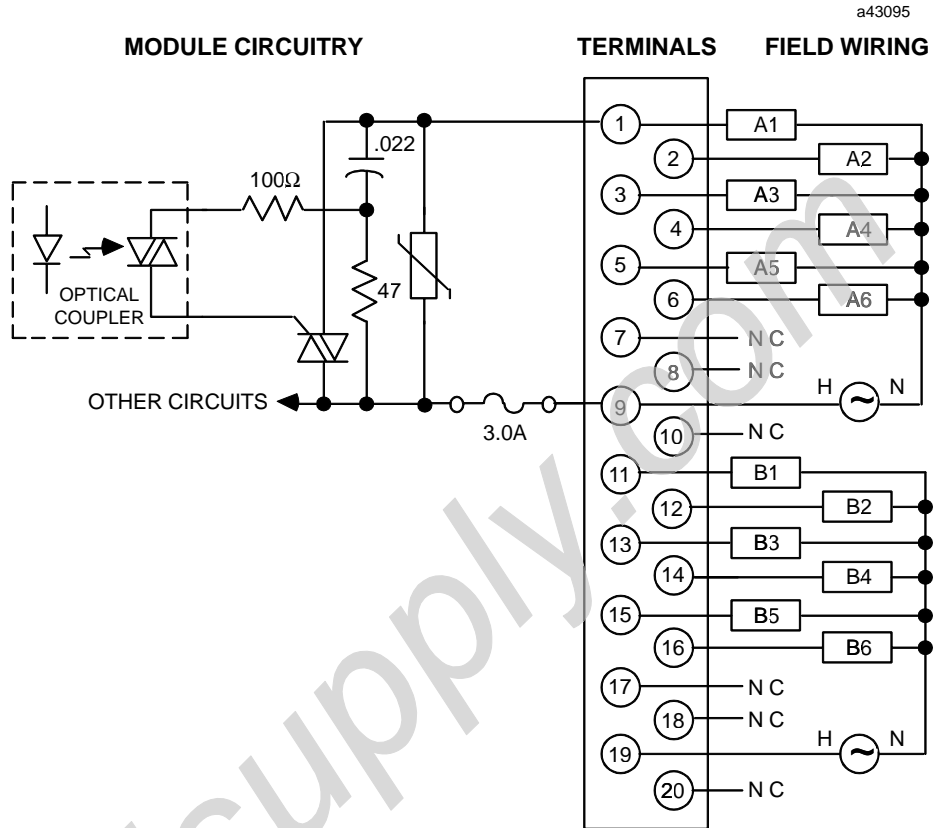

Figure 7-2. IC693MDL310 Output Module Field Wiring

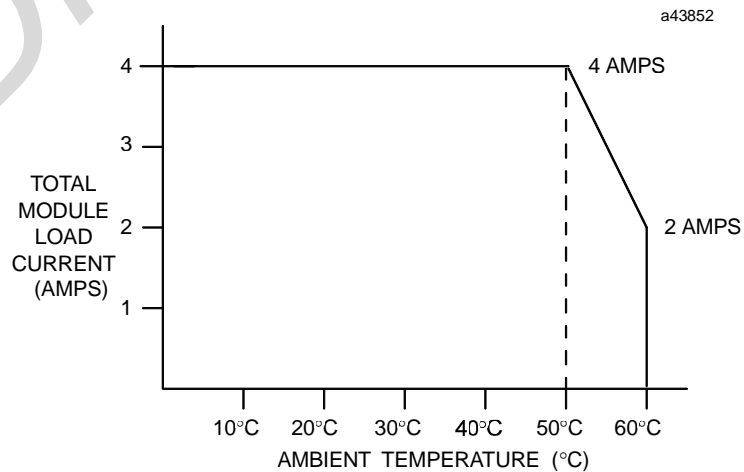

Figure 7-3. Input Points vs. Temperature for IC693MDL310